

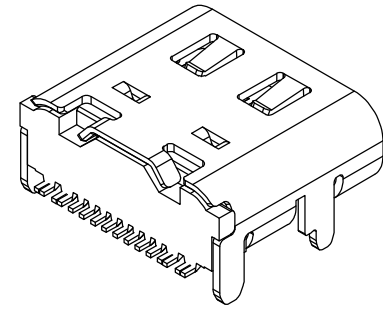

REV.	ECN NO OR DESCRIPTION	REVISED	DATE

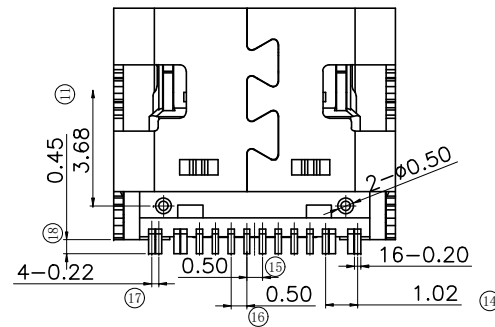

- 特性:
- 一、电气性能: ELECTRICAL
 1. 额定电流: 5.0A
 2. 接触阻抗: 40 MILLIOHMS MAX
 3. 耐电压: 150V AC / 1 mA MAX
 4. 绝缘阻抗: 150V DC/100 MEGA OHMS MIN
 - 二、机械性能:
 1. 插入力: 5~20N
 2. 拨出力: 8~20N
 3. 使用寿命: 10000次、拨出力 5N MIN
 - 三、材料: MATERIAL
 1. 塑胶: LCP/PA9T UL94V-0
 2. 端子: C7025/C18400 T=0.15MM
 3. 外壳: SUS304 T=0.30MM
 4. 卡勾: SUS304 T=0.20MM
 - 四、电镀: FINISH
 1. 端子: 接触点镀金3U"MIN
PIN脚焊接区域镀金1U"MIN.
 2. 外壳: 镀镍50U"MIN (盐雾48H)

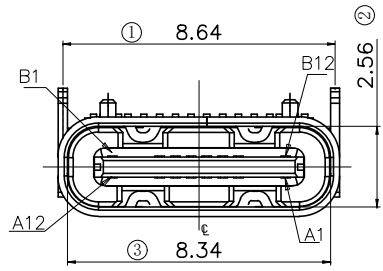
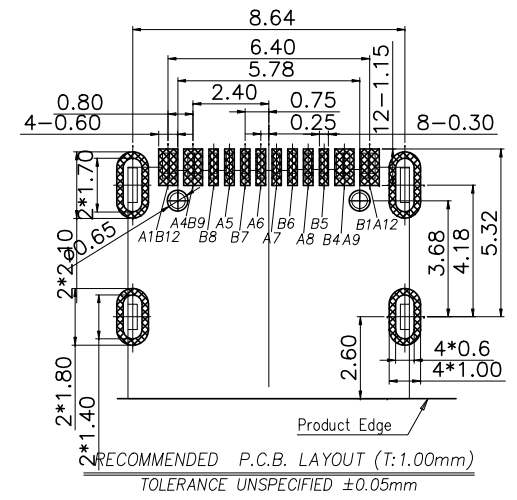
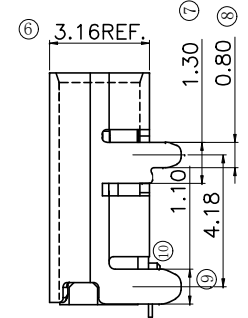
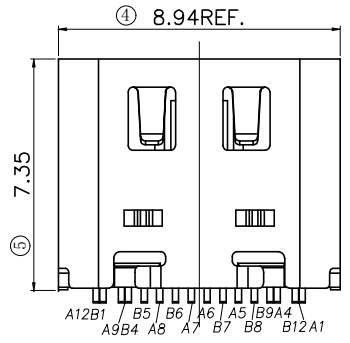

- 五、电镀品需做粘锡测试: 粘锡面积达到95%以上。
- 六、SMT回流焊 (峰值260° C±5° C) 不能起泡、熔胶、变色不良 (变形在公差范围以内)
- 七、工作温度: -40° C~+85° C

A1	GND	B12	GND
A4	VBUS	B9	VBUS
A5	CC1	B8	SBU2
A6	D+	B7	D-
A7	D-	B6	D+
A8	SBU1	B5	CC2
A9	VBUS	B4	VBUS
A12	GND	B1	GND
PIN	SIGNAL NAME	PIN	SIGNAL NAME

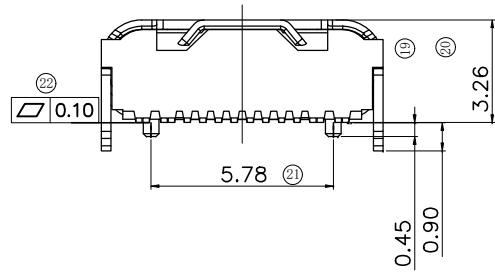

UNLESS OTHERWISE SPECIFIED TOLERANCES

DECIMALS: ANGLES:

X :±0.50 X :±2°

X.X :±0.25 X.X :±1°

X.XX :±0.15

东莞市汉博电子科技有限公司
DONGGUAN HANBO TECHNOLOGY CO., LTD

TITLE: TYPE C 16PIN 母座 板上SMT 外壳四脚插板有弹

DWN: xiong PART NO. MC-107DMS

CHKD: lee SCALE:1:1 UNIT: mm

APVD: wang SIZE: A4 SHEET:10F 1 REV: A4

CUSTOMER COPY



REV.	ECN NO OR DESCRIPTION	REVISED	DATE

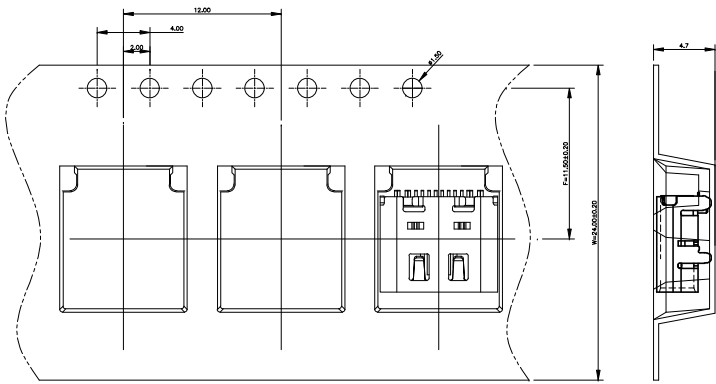

① 产品入载带示意图

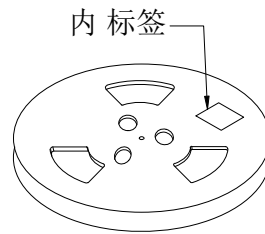

② 卷盘贴标签示意图

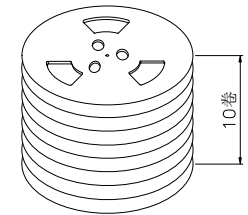

③ 10盘产品叠层示意图

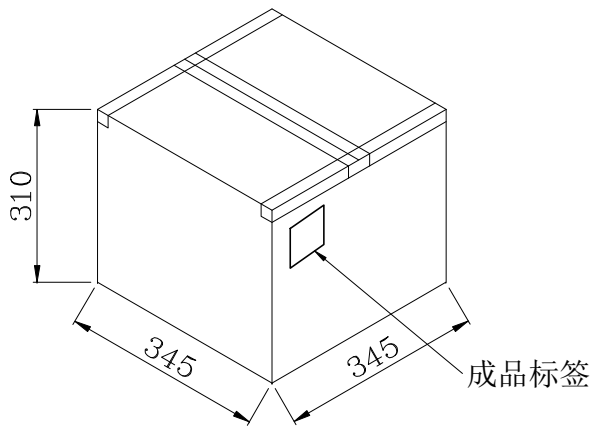

⑤ 外箱封箱示意图

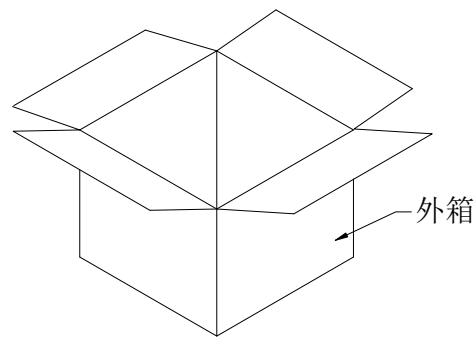

④ 产品入外箱示意图

包装说明:

1. 将检验好的成品;对插口朝前放入载带;每卷装1000PCS产品;具体如图一所示
2. 将包装好的产品;每盘必需贴上内标签;具体如图二所示
3. 将贴好内标签的产品每10盘叠;具体如图三所示
5. 装好后并封好纸箱及贴好相关标签;具体如图五所示;
(产品包装的标签,如客户有要求,请按客户要求包装出货)
6. 载带前面留10PCS空格,后面留10PCS空格
7. COVER与CARRY剥离力:50-125g,速度:300mm/分钟左右,剥离角度:165°-180°

UNLESS OTHERWISE SPECIFIED TOLERANCES		东莞市汉博电子科技有限公司 DONGGUAN HANBO TECHNOLOGY CO., LTD			
DECIMALS:	ANGLES:	TITLE	TYPE C 16PIN 母座 板上SMT 外壳四脚插板有弹		
X :±0.50	X :±2°	DWN	xiong	PART NO. MC-107DMS	
X.X :±0.25	X.X :±1°	CHKD	lee	SCALE:1:1	UNIT: mm
X.XX :±0.15		APVD	wang	SIZE: A4	SHEET:10F 1
		REV: A4			
CUSTOMER COPY					