

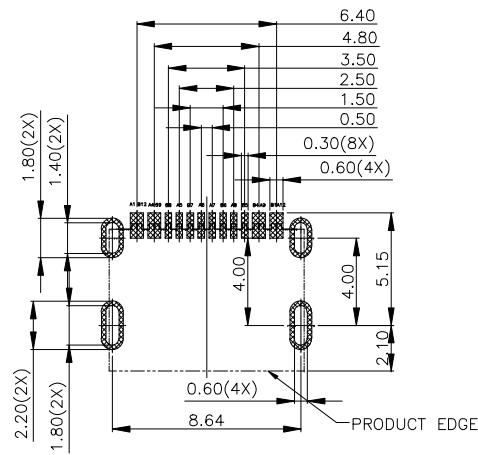

REV.	ECN NO OR DESCRIPTION	REVISED	DATE

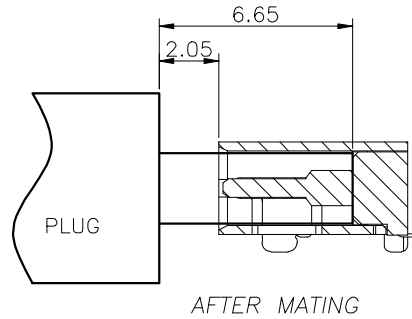

RECOMMENDED PCB LAYOUT(TOP VIEW)  
THICKNESS 0.60MM;DEFAULT TOLERANCE:±0.05

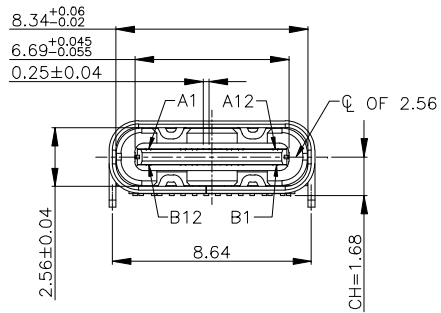
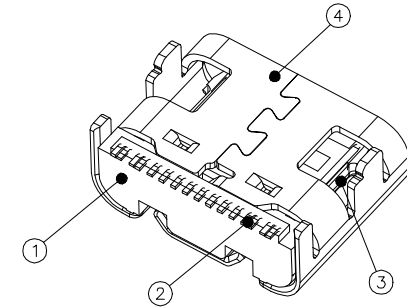

- NOTE:
- MATERIAL SPECIFICATION:
    - HOUSING: HIGH TEMPERATURE RESISTANT PLASTIC, UL94 V-0.
    - TERMINAL: COPPER ALLOY(C1814)
    - MID PLATE: STAINLESS STEEL(SUS301)
    - FRONT SHELL: STAINLESS STEEL(SUS304)
  - PLATING SPECIFICATION:
    - TERMINAL:
      - Ni 50u" MIN. UNDER PLATED OVER ALL.
      - Au PLATED ON THE FUNCTIONAL AREA OF CONTACT. (GOLD PLATING THICKNESS FOLLOW THE P/N)
      - PLATING SPECIFICATIONS OF THE SOLDER AREA FOLLOW THE P/N
    - FRONT SHELL:
      - PLATING SPECIFICATIONS FOLLOW THE P/N
    - MID PLATE:
      - CLEAR ONLY
  - MECHANICAL PERFORMANCE,
    - INSERTION FORCE: 0.5~2.0kgf.
    - REMOVAL FORCE: 0.8kgf~2.0kgf.
    - DURABILITY: 10000 CYCLES.
  - ELECTRICAL PERFORMANCE,
    - VOLTAGE RATING: 5 V DC/AC (RMS. max)  
CURRENT RATING: 5 AMPS. FOR TOTAL VBUS/GND PINS;  
1.25AMPS FOR CC PIN, 0.25 AMPS. FOR ALL OTHER CONTACT.
    - LLCR:
      - VBUS & GND PINS AND OTHER PINS: 40mA/PIN MAX.
      - SHIELD: 50mA/MAX.
      - LLCR MAX. CHANGE OF ALL PINS: 10mA.
    - INSULATION RESISTANCE: 100MΩ MIN
    - DIELECTRIC WITHSTAND VOLTAGE, AC 100V FOR 1 MINUTE.
  - ENVIRONMENTAL PERFORMANCE:
    - OPERATING TEMPERATURE: -25°C~+85°C.
  - IR REFLOW:
    - THE PEAK TEMPERATURE ON THE BOARD SHALL BE MAINTAINED FOR 10 SECONDS AT 260°C.

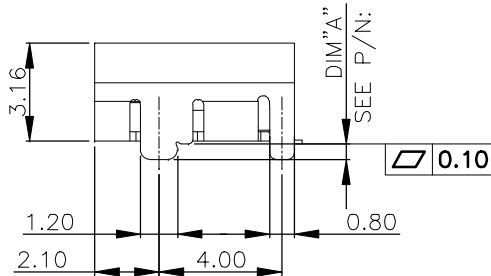
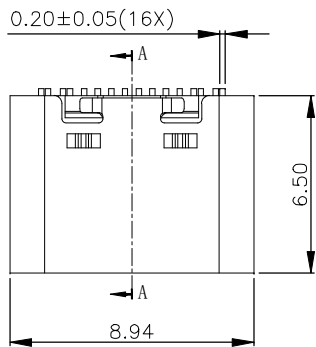

USB TYPE-C PIN ASSIGNMENTS

PIN NUMBER	SIGNAL NAME	PIN NUMBER	SIGNAL NAME
A1	GND	B12	GND
A4	VBUS	B9	VBUS
A5	CC1	B8	SBU2
A6	Dp1	B7	Dn2
A7	Dn1	B6	Dp2
A8	SBU1	B5	CC2
A9	VBUS	B4	VBUS
A12	GND	B1	GND

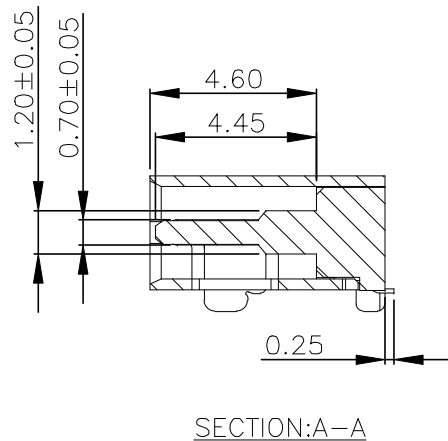
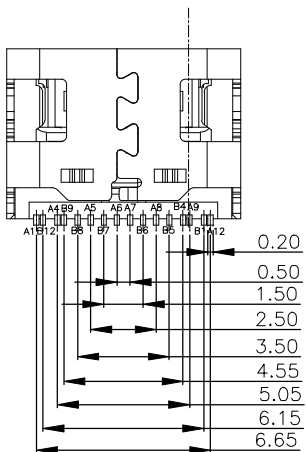

UNLESS OTHERWISE SPECIFIED TOLERANCES

DECIMALS: X ±0.30 X.X ±0.20 X.XX ±0.10

ANGLES: X ±2° X.X ±1°

**东莞市汉博电子科技有限公司**  
DONGGUAN HANBO TECHNOLOGY CO., LTD

TITLE: TYPE C母座单排16PIN贴板6.5长无弹脚长0.8

DWN xiong PART NO. MC-107DL65

CHKD lee SCALE:1:1 UNIT: mm

APVD wang SIZE: A4 SHEET:10F 1 REV: A4

CUSTOMER COPY



REV.	ECN NO OR DESCRIPTION	REVISED	DATE

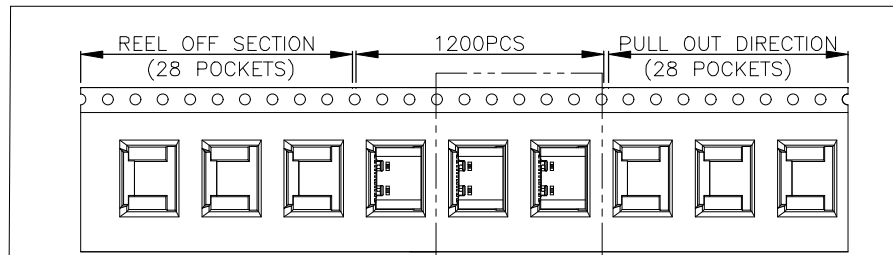

SEE DETAIL X

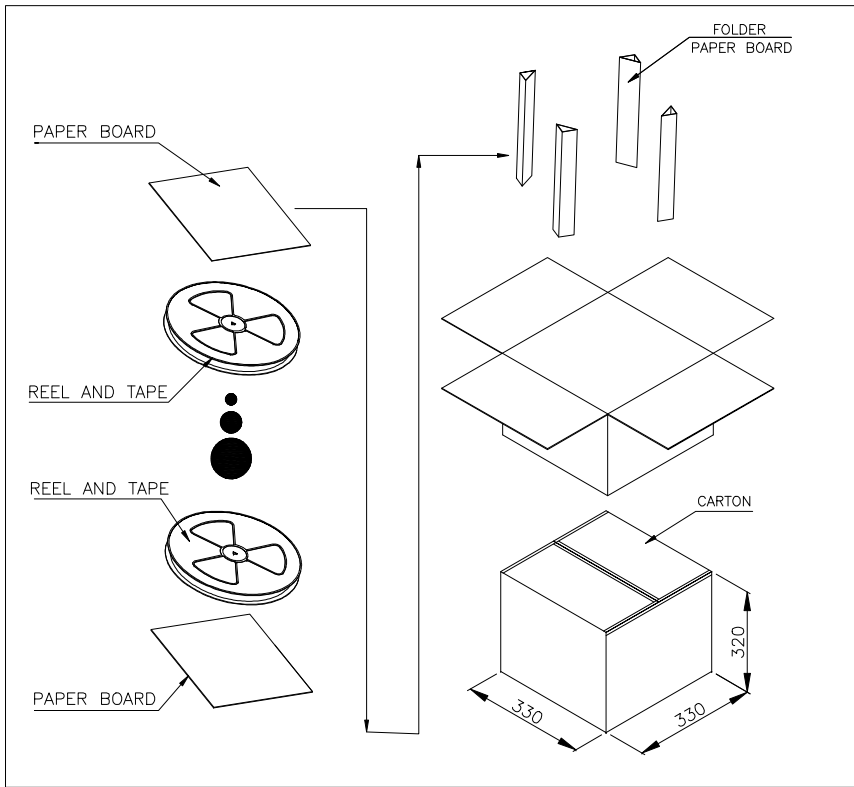
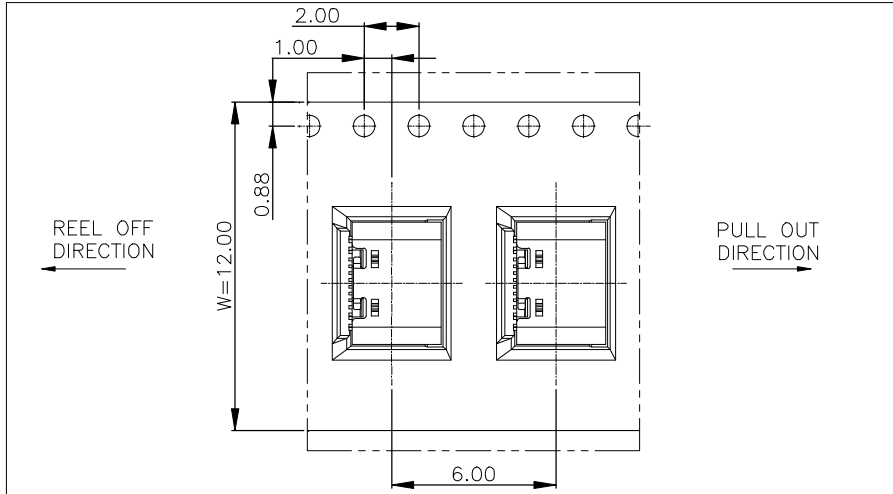
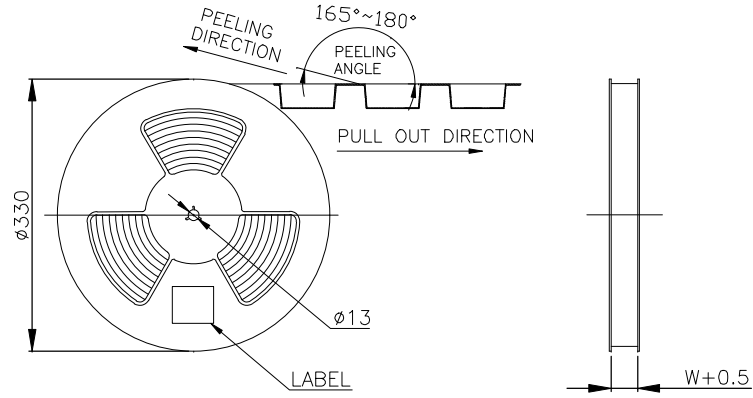

		REEL	CARTON
CONNECTOR (PCS)		1200	12000
UNLESS OTHERWISE SPECIFIED TOLERANCES		东莞市汉博电子科技有限公司 DONGGUAN HANBO TECHNOLOGY CO., LTD	
DECIMALS: ANGLES:		TITLE TYPE 母座单排16PIN贴板6.5长无弹脚长0.8	
X :±0.30	X :±2°	DWN xiong	PART NO. MC-107DL65
X.X :±0.20	X.X :±1°	CHKD lee	SCALE:1:1 UNIT: mm
X.XX :±0.10		APVD wang	SIZE: A4 SHEET:10F 1
		REV: A4	
CUSTOMER COPY			