

S-1.5SMC*** ASeries

SURFACE MOUNT TRANSIENT VOLTAGE SUPPRESSOR

VOLTAGE 6.8 TO 250 Volts, 1500 Watt Peak Pulse Power

1. FEATURES

- We declare that the material of product compliance with RoHS requirements and Halogen Free.
- Plastic package has Underwriters Laboratory Flammability Classification 94V-0
- For surface mounted applications in order to optimize board space
- Low profile package
- Built-in strain relief
- Glass passivated junction
- Low inductance
- Excellent clamping capability
- Repetition Rate (duty cycle):0.01%
- Fast response time: typically less than 1.0ps
- Typical IR less than 1uA above 10V
- High temperature soldering guaranteed:
260°C/10 seconds,
- Weight: 0.26g
- S- prefix for automotive and other applications requiring unique site and control change requirements; AEC-Q101 qualified and PPAP capable.

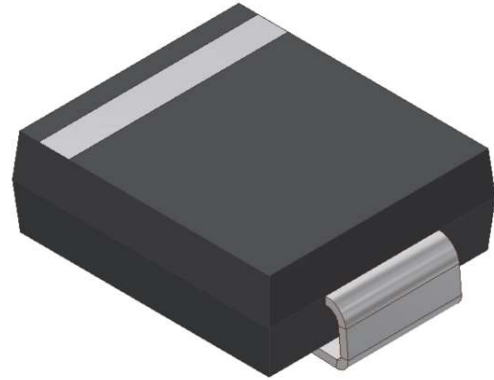

2.MECHANICAL DATA

Case: JEDEC DO-214AB (SMC)

Terminals: Plated leads, solderable per MIL-STD-202, Method 208

Polarity: Color band denoted cathode

Mounting Position: Any

3. MAXIMUM RATINGS(Ta = 25°C)

Ratings at 25°C ambient temperature unless otherwise specified.

Single phase, half wave, 60Hz, resistive or inductive load.

For capacitive load, derate current by 20%.

RATING	VALUE	UNITS
Peak Power Dissipation at T _A =25°C, T _P =1ms(Note 1)	Minimum 1500	Watts
Steady State Power Dissipation at T _L =75°C(Note 2)	5.0	Watts
Peak Forward Surge Current,8.3ms Single Half Sine-WaveSuperimposed on Rated Load, (JEDEC Method)	200	A
Typical thermal resistance (Note 2)	80 (RθJA)	°C/W
	20 (RθJC)	
Operating Temperature Range	-55 to +150	°C
Storage Temperature Range	-55 to +150	°C

NOTES:

1. Non-repetitive current pulse, per Fig. 3 and derated above TA=25°C per Fig. 2.
2. Mounted on 0.31 x 0.31" (8.0 x 8.0mm) copper pads to each terminal.



S-1.5SMC*** ASeries

Uni-Directional Part Number	Device marking code	Reverse Stand-off Voltage VRWM (V)	Breakdown Voltage VBR (V) Min. @IT	Breakdown Voltage VBR (V) Max. @IT	Test Current IT (mA)	Maximum Clamping Voltage @IPP VC (V)	Peak Pulse Current Ipp (A)	Reverse Leakage @VRWM IR (uA)
S-1.5SMC6.8A	1.5SMC6.8A	5.8	6.45	7.14	10	10.5	142.9	1000
S-1.5SMC7.5A	1.5SMC7.5A	6.4	7.13	7.88	10	11.3	132.7	500
S-1.5SMC8.2A	1.5SMC8.2A	7.02	7.79	8.61	10	12.1	124.0	200
S-1.5SMC9.1A	1.5SMC9.1A	7.78	8.65	9.5	1	13.4	111.9	50
S-1.5SMC10A	1.5SMC10A	8.55	9.5	10.5	1	14.5	103.4	10
S-1.5SMC11A	1.5SMC11A	9.4	10.5	11.6	1	15.6	96.2	1
S-1.5SMC12A	1.5SMC12A	10.2	11.4	12.6	1	16.7	89.8	1
S-1.5SMC13A	1.5SMC13A	11.1	12.4	13.7	1	18.2	82.4	1
S-1.5SMC15A	1.5SMC15A	12.8	14.3	15.8	1	21.2	70.8	1
S-1.5SMC16A	1.5SMC16A	13.6	15.2	16.8	1	22.5	66.7	1
S-1.5SMC18A	1.5SMC18A	15.3	17.1	18.9	1	25.2	59.5	1
S-1.5SMC20A	1.5SMC20A	17.1	19	21	1	27.7	54.2	1
S-1.5SMC22A	1.5SMC22A	18.8	20.9	23.1	1	30.6	49.0	1
S-1.5SMC24A	1.5SMC24A	20.5	22.8	25.2	1	33.2	45.2	1
S-1.5SMC27A	1.5SMC27A	23.1	25.7	28.4	1	37.5	40.0	1
S-1.5SMC30A	1.5SMC30A	25.6	28.5	31.5	1	41.4	36.2	1
S-1.5SMC33A	1.5SMC33A	28.2	31.4	34.7	1	45.7	32.8	1
S-1.5SMC36A	1.5SMC36A	30.8	34.2	37.8	1	49.9	30.1	1
S-1.5SMC39A	1.5SMC39A	33.3	37.1	41	1	53.9	27.8	1
S-1.5SMC43A	1.5SMC43A	36.8	40.9	45.2	1	59.3	25.3	1
S-1.5SMC47A	1.5SMC47A	40.2	44.7	49.4	1	64.8	23.1	1
S-1.5SMC51A	1.5SMC51A	43.6	48.5	53.6	1	70.1	21.4	1
S-1.5SMC56A	1.5SMC56A	47.8	53.2	58.8	1	77	19.5	1
S-1.5SMC62A	1.5SMC62A	53	58.9	65.1	1	85	17.6	1
S-1.5SMC68A	1.5SMC68A	58.1	64.6	71.4	1	92	16.3	1
S-1.5SMC75A	1.5SMC75A	64.1	71.3	78.8	1	103	14.6	1
S-1.5SMC82A	1.5SMC82A	70.1	77.9	86.1	1	113	13.3	1
S-1.5SMC91A	1.5SMC91A	77.8	86.5	95.5	1	125	12.0	1
S-1.5SMC100A	1.5SMC100A	85.5	95	105	1	137	10.9	1
S-1.5SMC110A	1.5SMC110A	94	105	116	1	152	9.9	1
S-1.5SMC120A	1.5SMC120A	102	114	126	1	165	9.1	1
S-1.5SMC130A	1.5SMC130A	111	124	137	1	179	8.4	1
S-1.5SMC150A	1.5SMC150A	128	143	158	1	207	7.2	1
S-1.5SMC160A	1.5SMC160A	136	152	168	1	219	6.8	1
S-1.5SMC170A	1.5SMC170A	145	162	179	1	234	6.4	1
S-1.5SMC180A	1.5SMC180A	154	171	189	1	246	6.1	1
S-1.5SMC200A	1.5SMC200A	171	190	210	1	274	5.5	1
S-1.5SMC220A	1.5SMC220A	185	209	231	1	328	4.6	1
S-1.5SMC250A	1.5SMC250A	214	237	263	1	344	4.4	1
S-1.5SMC300A	1.5SMC300A	256	285	315	1	414	3.7	1

5. ELECTRICAL CHARACTERISTICS CURVES

Fig. 1-Peak Pulse Power Rating Curve

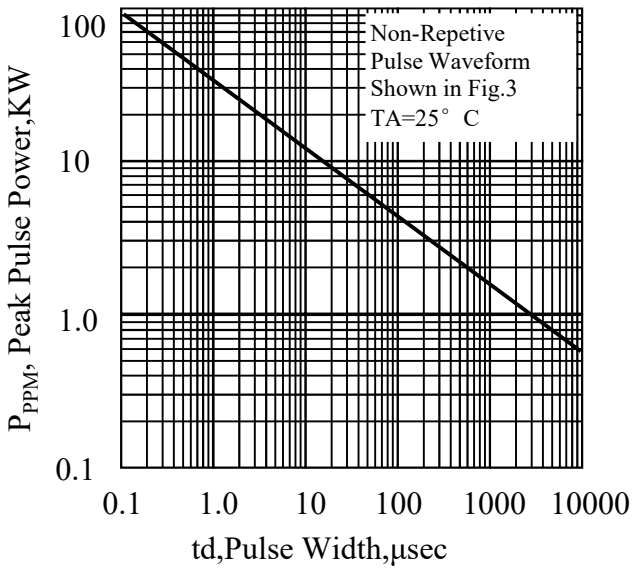

Fig. 2-Pulse Derating Curve

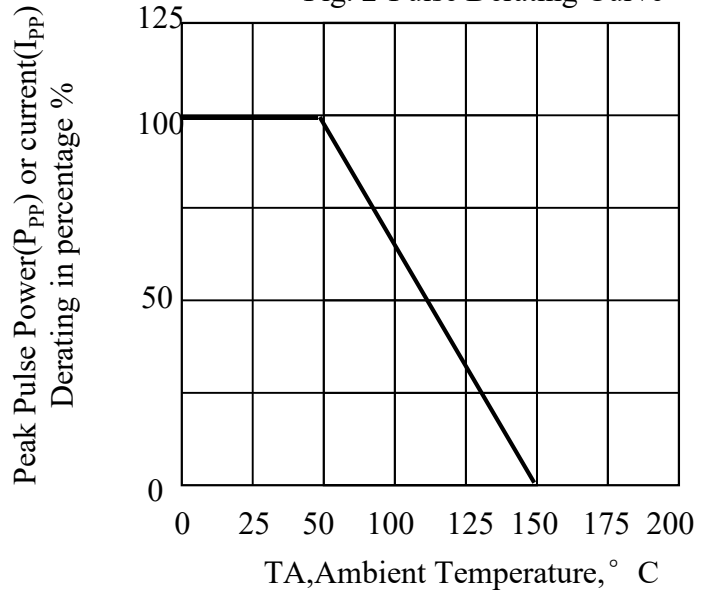

Fig. 3-Pulse Waveform

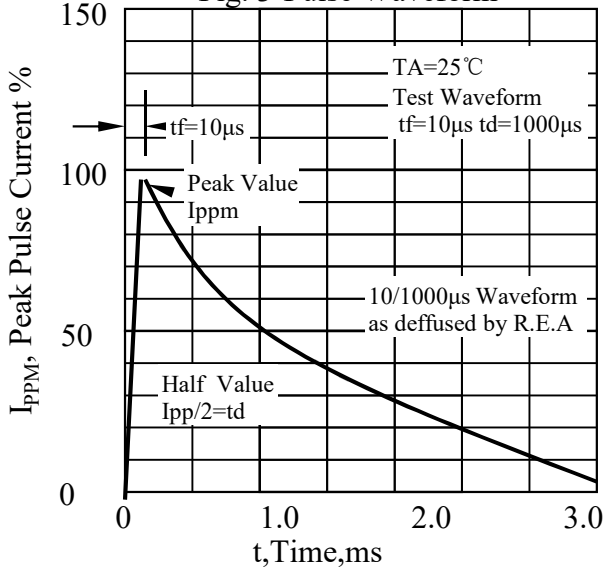
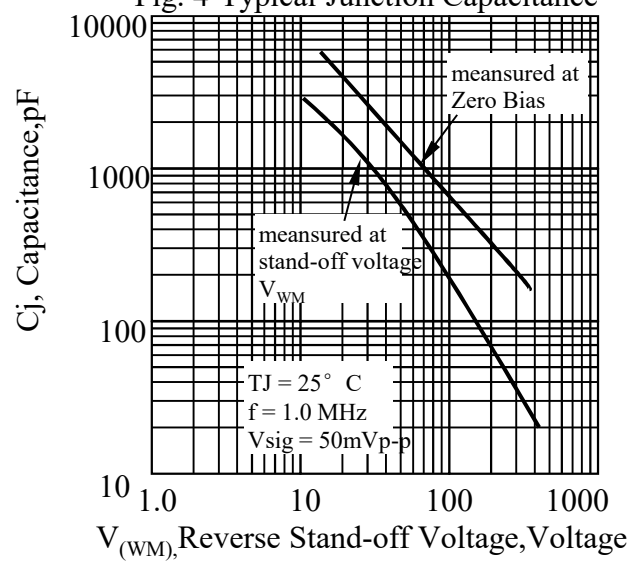
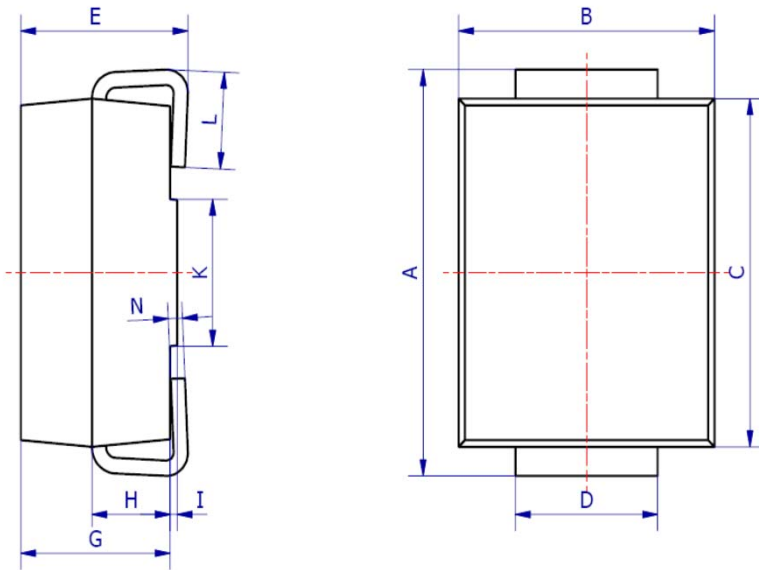

Fig. 4-Typical Junction Capacitance



6. OUTLINE AND DIMENSIONS



SMC			
DIM	Min	Max	Typ.
A	7.70	8.30	8.00
B	5.85	6.25	6.05
C	6.65	7.05	6.85
D	2.80	3.20	3.00
E	2.45	2.85	2.65
G	2.10	2.50	2.30
H	1.00	1.40	1.20
I	0.05	0.15	0.10
K	4.30	4.70	4.50
L	1.00	1.50	1.25
N	0.10	0.30	0.20
All Dimensions in mm			

7. SOLDERING FOOTPRINT

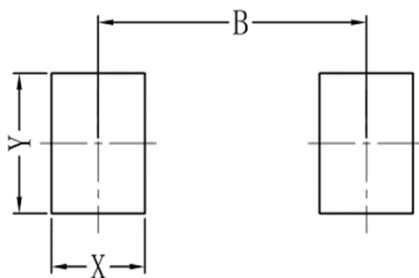

SMC	
DIM	(mm)
X	1.60
Y	3.30
B	6.60