

# LNP2010DT2AG

## N- AND P-Channel Enhancement Mode MOSFET

### 1. FEATURES

- P-Channel:  $V_{DS} = -20V$   
 $R_{DS(ON)}, V_{GS}@-4.5V, I_{DS}@-4.7A=70m\Omega$   
 $R_{DS(ON)}, V_{GS}@-2.5V, I_{DS}@-1.0A=110m\Omega$
- N-Channel:  $V_{DS} = 20V$   
 $R_{DS(ON)}, V_{GS}@2.5V, I_{DS}@5.2A = 50m\Omega$   
 $R_{DS(ON)}, V_{GS}@4.5V, I_{DS}@6A = 40m\Omega$
- Simple drive requirement.
- Low gate charge.
- Low on-resistance.
- Fast switching speed.
- We declare that the material of product compliance with RoHS requirements and Halogen Free.

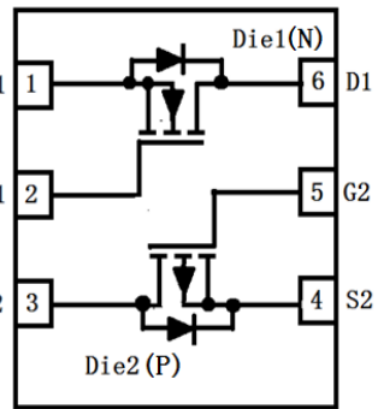
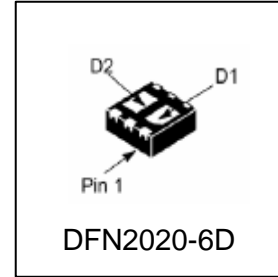

### 2. DEVICE MARKING AND ORDERING INFORMATION

Device	Marking	Shipping
LNP2010DT2AG	T2	4000/Tape&Reel

### 3. MAXIMUM RATINGS( $T_a = 25^\circ C$ )

Parameter (P-Channel)	Symbol	Limits	Unit
Drain–Source Voltage	$V_{DSS}$	-20	V
Gate–to–Source Voltage – Continuous	$V_{GS}$	$\pm 12$	V
Drain Current			
– Continuous $T_A = 25^\circ C$	$I_D$	-4.7	A
– Pulsed(Note 1)	$I_{DM}$	-20	

Parameter (N-Channel)	Symbol	Limits	Unit
Drain–Source Voltage	$V_{DSS}$	20	V
Gate–to–Source Voltage – Continuous	$V_{GS}$	$\pm 12$	V
Drain Current			
– Continuous $T_A = 25^\circ C$	$I_D$	6	A
– Pulsed(Note 1)	$I_{DM}$	33	

1. Repetitive Rating: Pulse width limited by the Maximum junction temperature.

**4. THERMAL CHARACTERISTICS**

Parameter	Symbol	Limits	Unit
Maximum Power Dissipation(Note 2)	PD	1.38	W
Thermal Resistance,Junction-to-Ambient	R $\theta$ JA	90	$^{\circ}$ C/W
Thermal Resistance,Junction-to-Ambient(Note 3)	R $\theta$ JA	160	
Junction and Storage temperature	T <sub>J</sub> ,T <sub>stg</sub>	-55~+150	$^{\circ}$ C

2.Surface mounted on 1 in<sup>2</sup> copper pad of FR-4 board, t  $\leq$  5 sec.

3.Surface mounted on FR4 board using the recommended pad size.

**5. ELECTRICAL CHARACTERISTICS (Ta= 25 $^{\circ}$ C)**
**P-Channel**

Characteristic	Symbol	Min.	Typ.	Max.	Unit
<b>STATIC</b>					
Drain-Source Breakdown Voltage (V <sub>GS</sub> = 0 V, I <sub>D</sub> = -250 $\mu$ A)	V <sub>BRDSS</sub>	-20	-	-	V
Gate Threshold Voltage (V <sub>DS</sub> = V <sub>GS</sub> , I <sub>D</sub> = -250 $\mu$ A)	V <sub>GS(th)</sub>	-0.6	-0.85	-1.4	V
Zero Gate Voltage Drain Current (V <sub>GS</sub> = 0, V <sub>DS</sub> = -20 V)	I <sub>DSS</sub>	-	-	-1	$\mu$ A
Gate-to-Source Leakage Current (V <sub>DS</sub> = 0 V, V <sub>GS</sub> = $\pm$ 12 V)	I <sub>GSS</sub>	-	-	$\pm$ 100	nA
Drain-to-Source On Resistance(Note 4) (V <sub>GS</sub> = -4.5 V, I <sub>D</sub> = -4.7 A) (V <sub>GS</sub> = -2.7 V, I <sub>D</sub> = -3.8 A) (V <sub>GS</sub> = -2.5 V, I <sub>D</sub> = -1.0 A)	R <sub>DS(on)</sub>	-	58 63 75	70 90 110	m $\Omega$
Forward Voltage (V <sub>GS</sub> = 0 V, I <sub>SD</sub> = -1.7 A)	V <sub>SD</sub>	-	-	-1.2	V
<b>DYNAMIC</b>					
Total Gate Charge	(V <sub>GS</sub> = -10 V, V <sub>DS</sub> = -4.7 V, I <sub>D</sub> = -4.5 A)	Q <sub>g</sub>	-	13.9	-
Gate-to-Source Gate Charge		Q <sub>gs</sub>	-	1.02	-
Gate-to-Drain Charge		Q <sub>gd</sub>	-	1.94	-
Turn-On Delay Time	(V <sub>DD</sub> = -10 V, R <sub>L</sub> = 10 $\Omega$ , I <sub>D</sub> = -1 A, V <sub>GEN</sub> = -4.5 V, R <sub>G</sub> = 6.2 $\Omega$ )	t <sub>d(on)</sub>	-	16.5	-
Rise Time		t <sub>r</sub>	-	23.4	-
Turn-Off Delay Time		t <sub>d(off)</sub>	-	66.5	-
Fall Time		t <sub>f</sub>	-	33.3	-
Input Capacitance (V <sub>DS</sub> = -8 V, V <sub>GS</sub> = 0 V, f = 1.0 MHz)	C <sub>iss</sub>	-	751	-	pF
Output Capacitance (V <sub>DS</sub> = -8 V, V <sub>GS</sub> = 0 V, f = 1.0 MHz)	C <sub>oss</sub>	-	91	-	
Reverse Transfer Capacitance (V <sub>DS</sub> = -8 V, V <sub>GS</sub> = 0 V, f = 1.0 MHz)	C <sub>rss</sub>	-	84	-	

**5. ELECTRICAL CHARACTERISTICS (Ta= 25°C)(Con.)**
**N-Channel**

Characteristic	Symbol	Min.	Typ.	Max.	Unit	
<b>Static</b>						
Drain–Source Breakdown Voltage (VGS = 0 V, ID = 250 μA)	V(BR)DSS	20	-	-	V	
Drain-Source On-State Resistance(Note 4) (VGS = 2.5 V, ID= 5.2 A) (VGS = 4.5 V, ID = 6 A)	RDS(on)	- -	42 33	50 40	mΩ	
Gate Threshold Voltage (VDS = VGS, ID = 250 μA)	VGS(th)	0.4	-	1	V	
Zero Gate Voltage Drain Current (VDS= 20 V, VGS= 0 V)	IDSS	-	-	1	μA	
Gate Body Leakage (VDS = 0 V, VGS = ±12 V)	IGSS	-	-	±100	nA	
<b>DYNAMIC(Note 3)</b>						
Total Gate Charge	(VDS = 10V, ID = 6 A, VGS = 4.5 V)	Qg	-	6.8	-	nC
Gate-to–Source Gate Charge		Qgs	-	1	-	
Gate-to–Drain Charge		Qgd	-	2	-	
Turn-On Delay Time	(VDD = 10 V, ID = 1 A, VGS = 4.5 V, RG = 6.2Ω)	td(on)	-	10.8	-	ns
Rise Time		tr	-	15.3	-	
Turn-Off Delay Time		td(off)	-	76.7	-	
Fall Time		tf	-	23.8	-	
Input Capacitance (VDS = 8 V, VGS = 0 V, f = 1.0 MHz)	Ciss	-	636	-	pF	
Output Capacitance (VDS = 8 V, VGS = 0 V, f = 1.0 MHz)	Coss	-	62.8	-		
Reverse Transfer Capacitance (VDS = 8 V, VGS = 0 V, f = 1.0 MHz)	Crss	-	59.6	-		
<b>SOURCE–DRAIN DIODE</b>						
Max. Diode Forward Current	IS	-	-	1.7	A	
Forward Voltage (VGS = 0 V, IS = 1.7 A)	VSD	-	-	1.2	V	

4.Pulse Test: Pulse Width ≤300 μs, Duty Cycle ≤2.0%.

## 6. ELECTRICAL CHARACTERISTICS CURVES

P-Channel

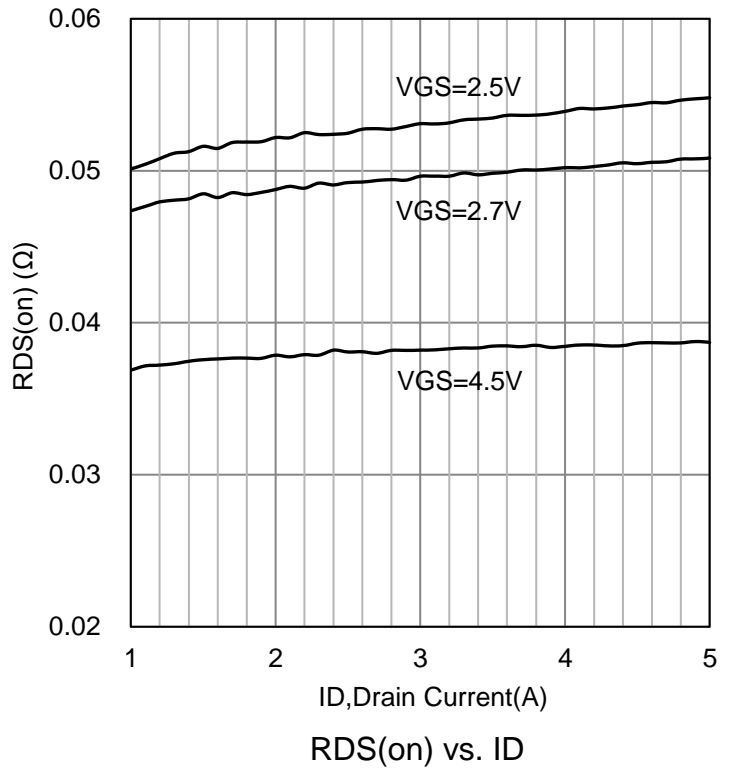
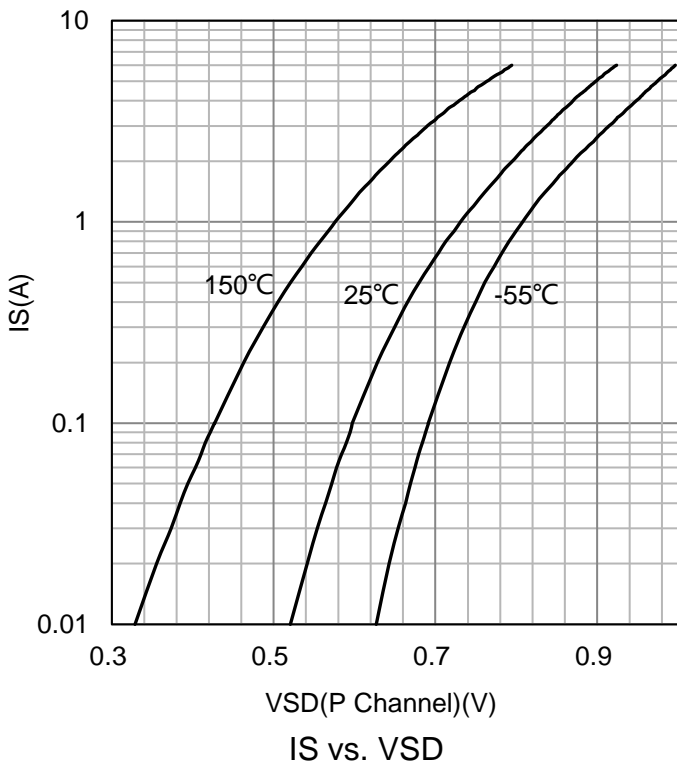
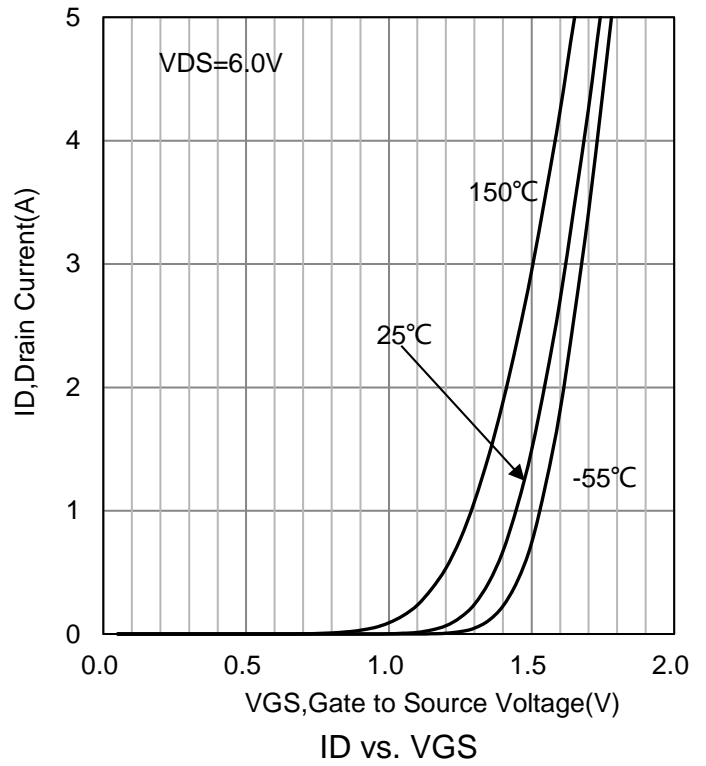
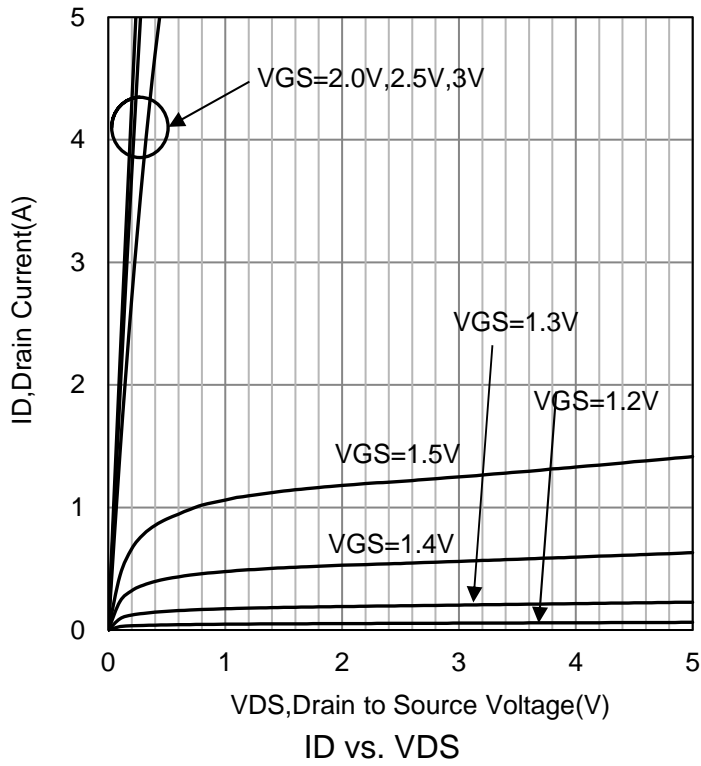

### 6. ELECTRICAL CHARACTERISTICS CURVES(Con.)

P-Channel

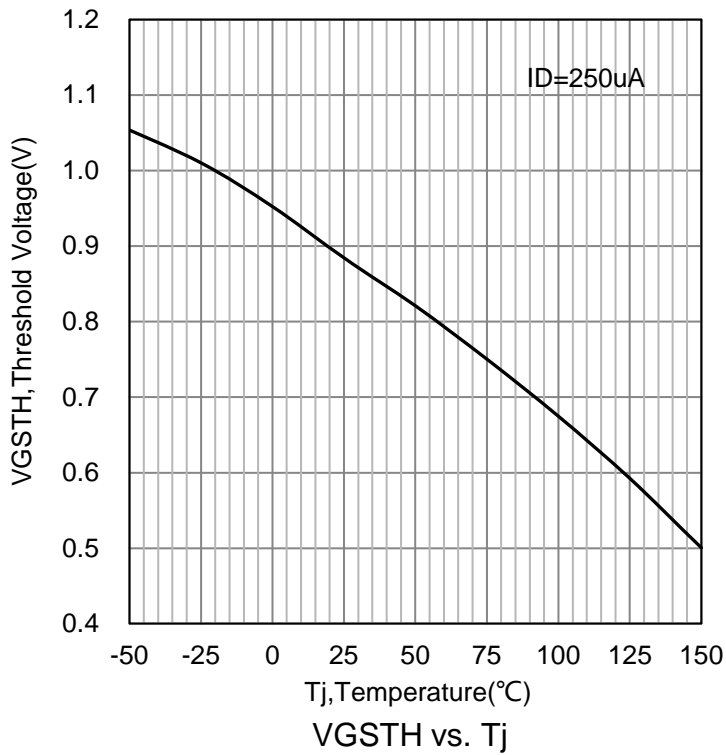
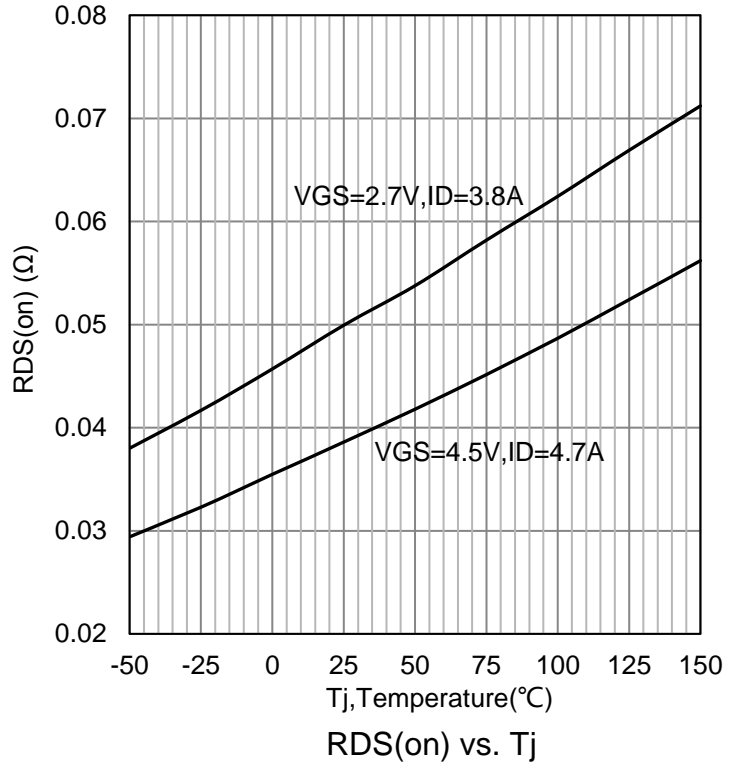
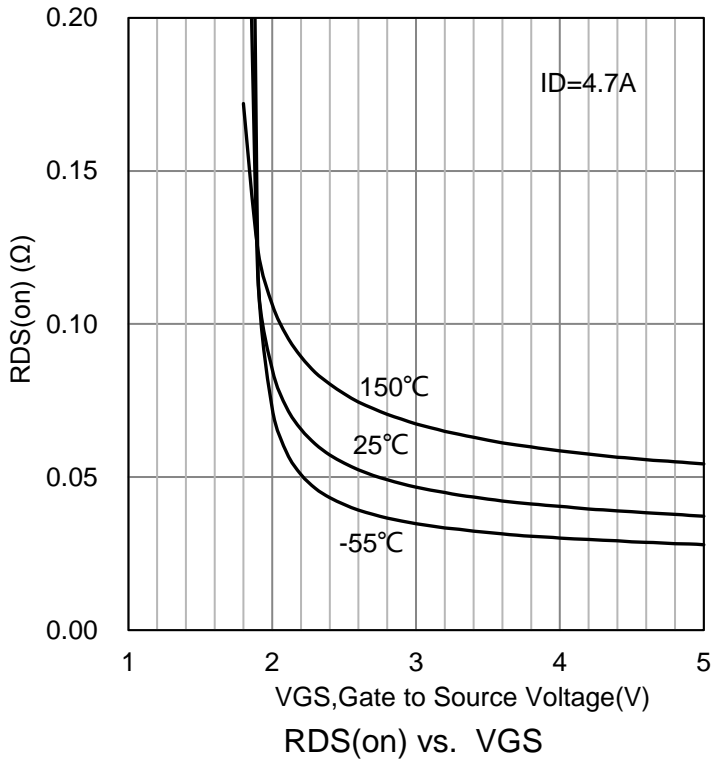

**6. ELECTRICAL CHARACTERISTICS CURVES(Con.)**

P-Channel

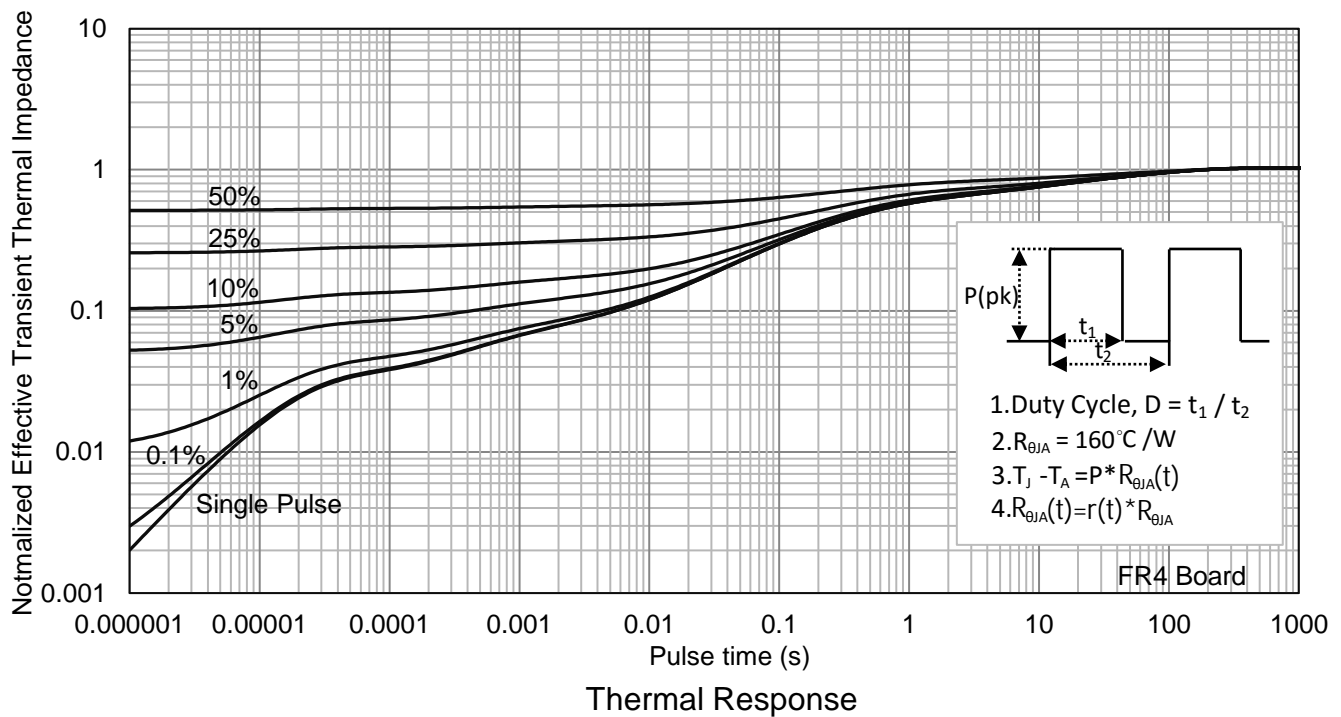
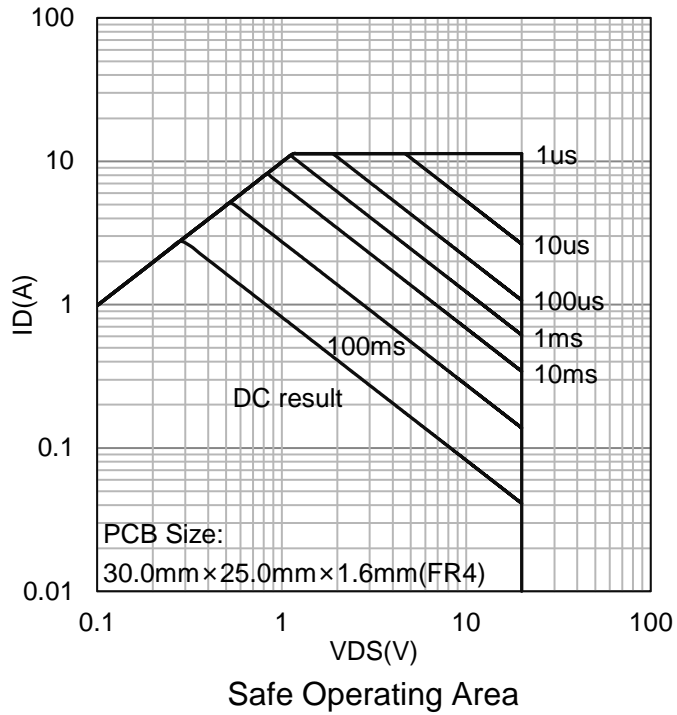

## 6. ELECTRICAL CHARACTERISTICS CURVES

N-Channel

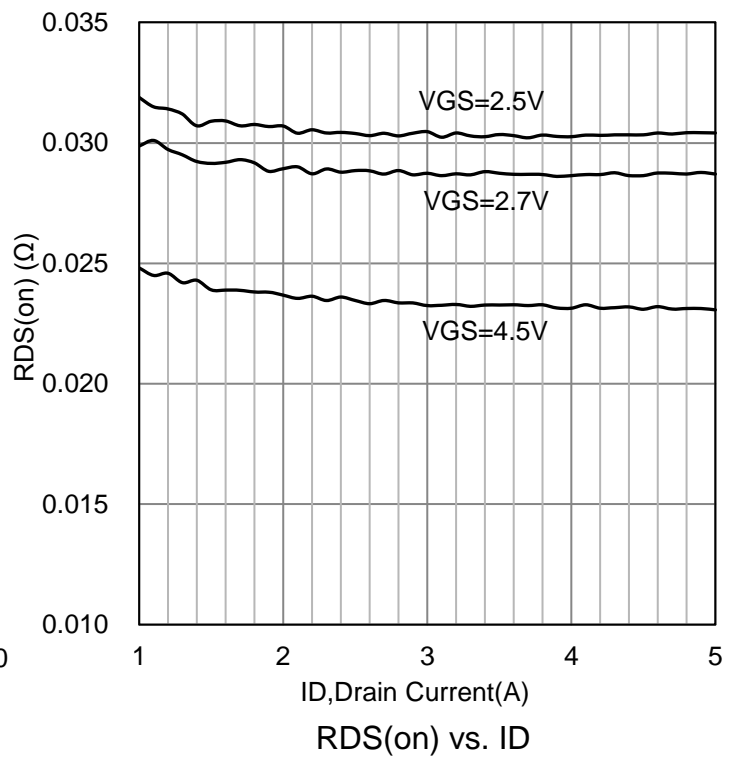
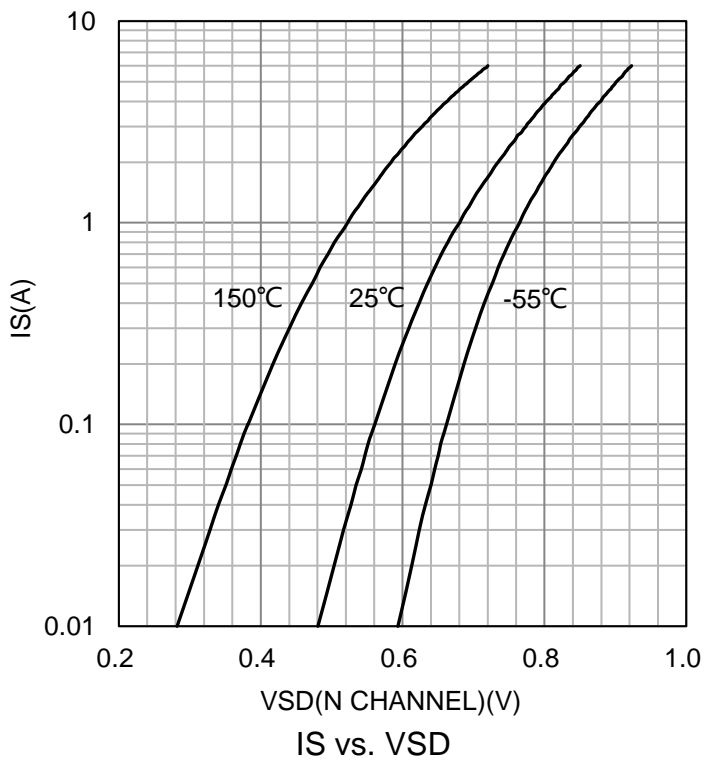
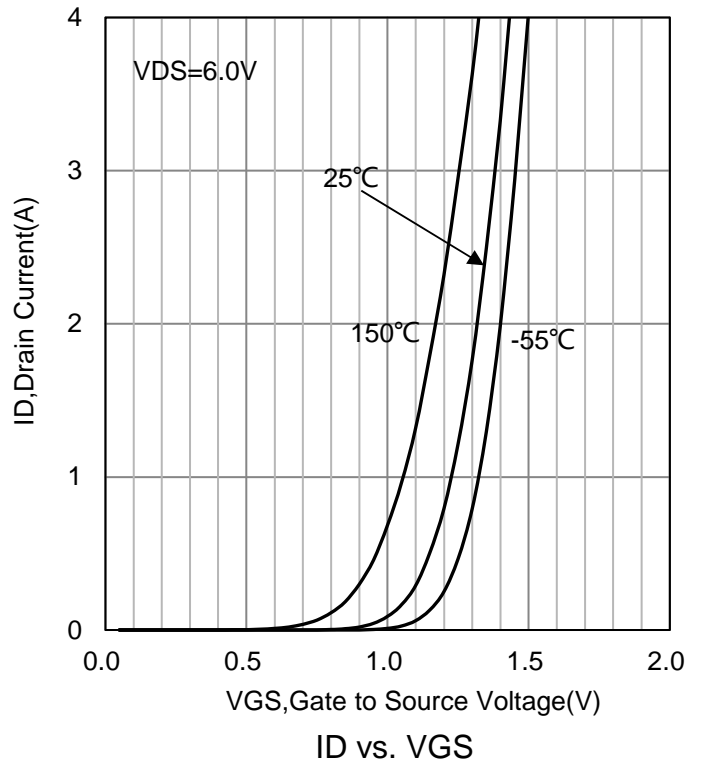
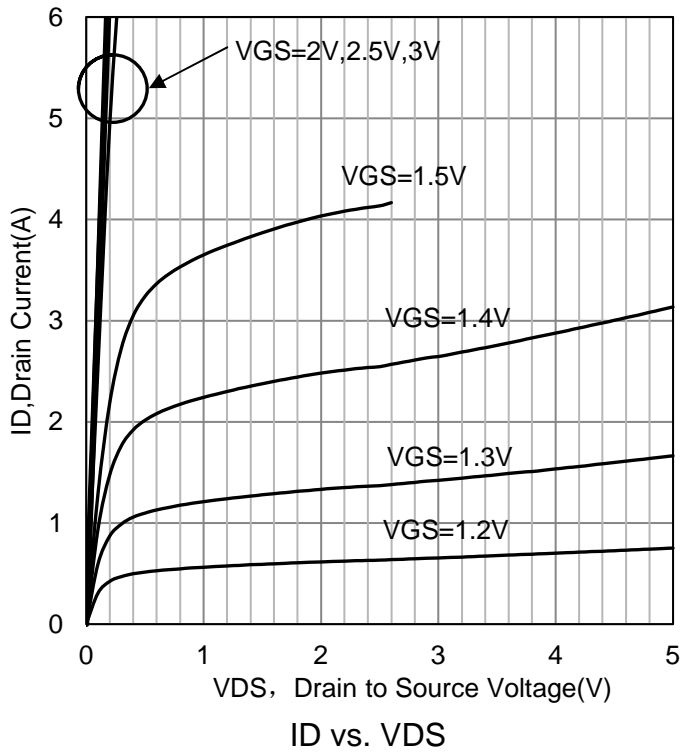

### 6. ELECTRICAL CHARACTERISTICS CURVES(Con.)

N-Channel

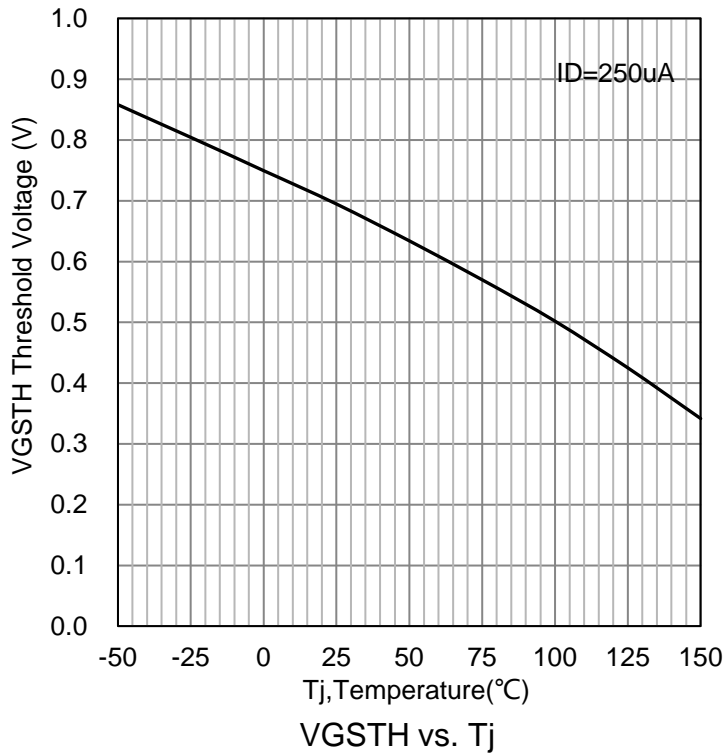
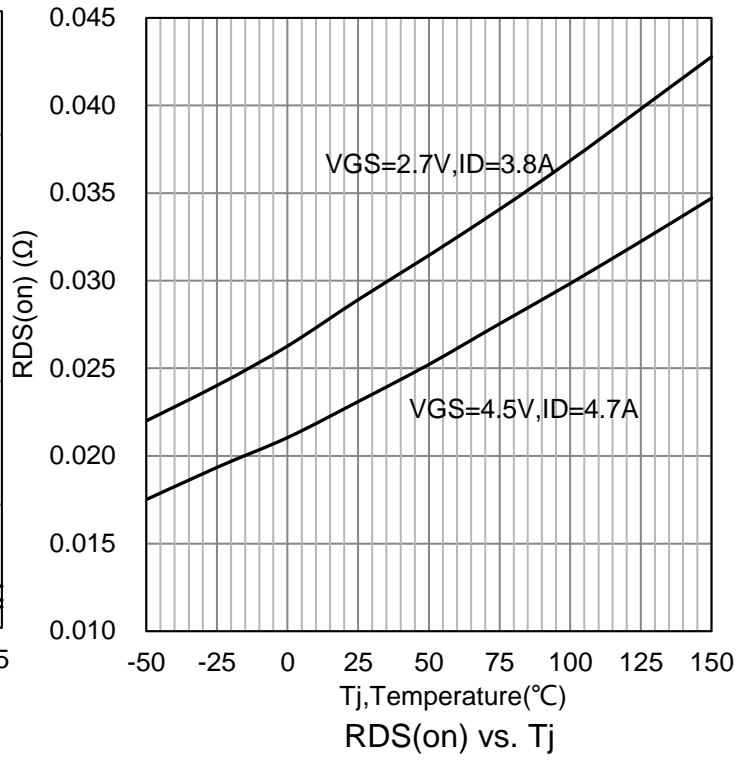
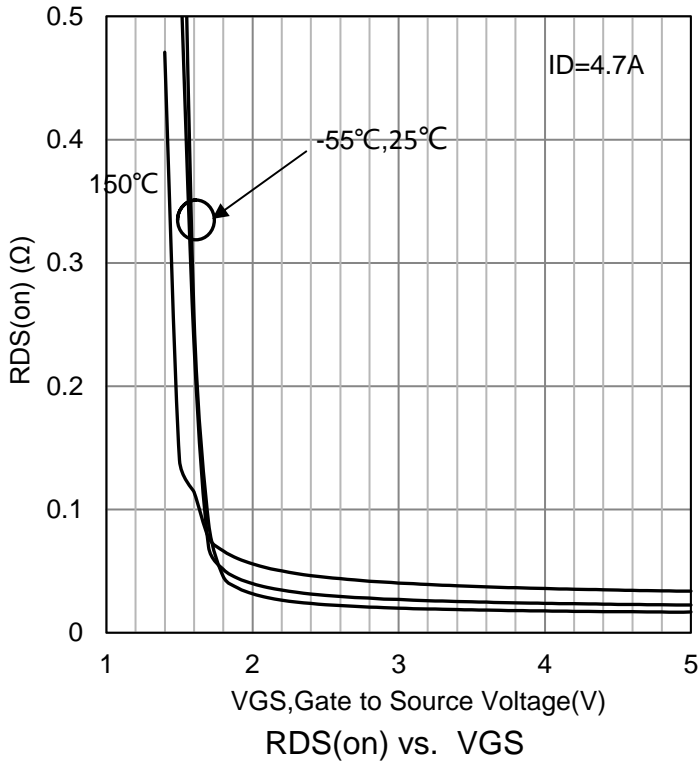

### 6. ELECTRICAL CHARACTERISTICS CURVES(Con.)

N-Channel

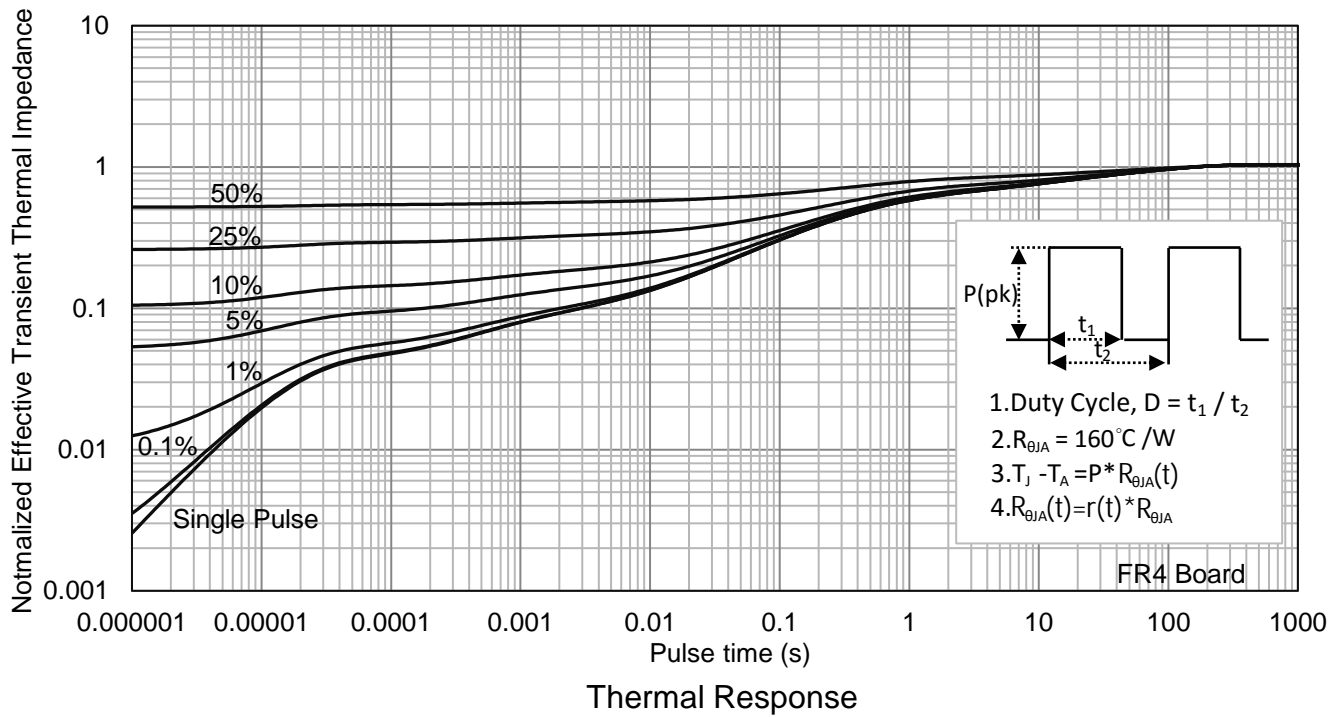
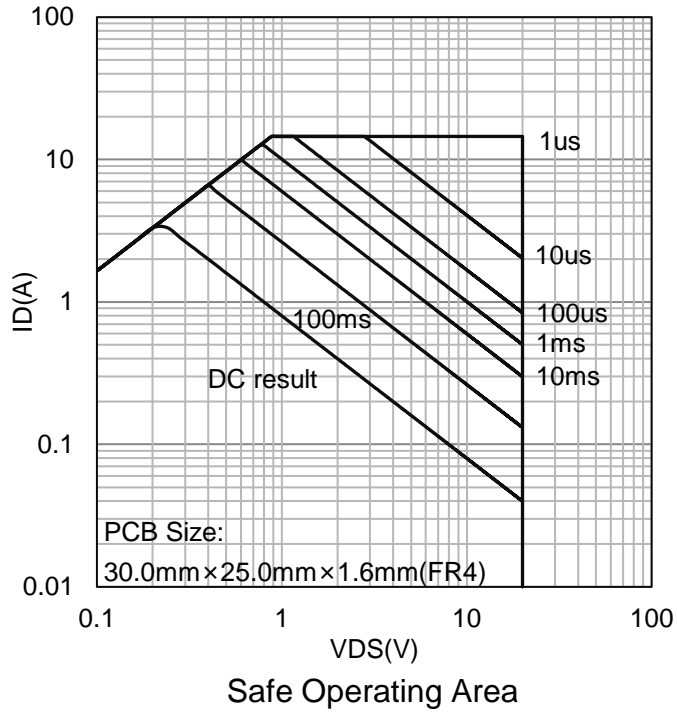

### 7. OUTLINE AND DIMENSIONS

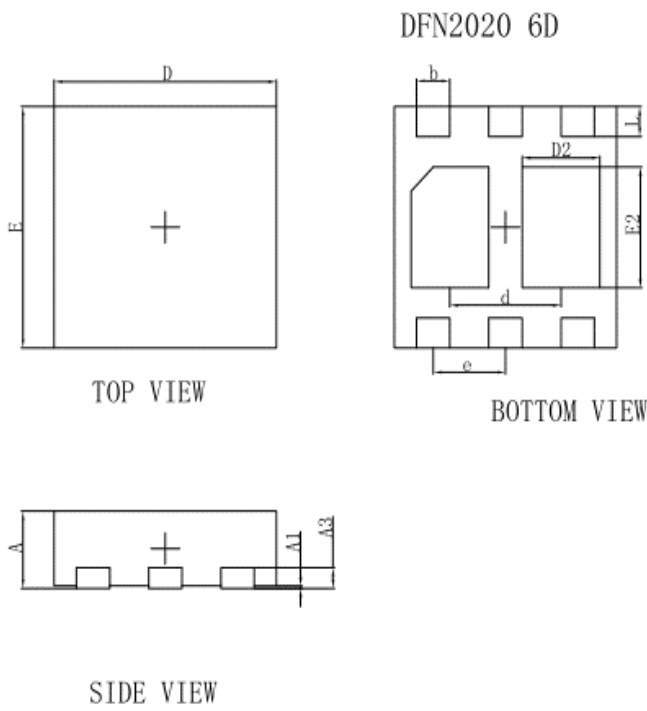

DFN2020-6D			
Dim	Min	Typ	Max
D	1.95	2	2.05
E	1.95	2	2.05
e	-	0.65	-
L	0.20	0.25	0.30
b	0.25	0.3	0.35
d	-	1	-
A	0.60	0.65	0.70
A1	0.00	0.02	0.05
A3	-	0.152	-
E2	0.95	1	1.05
D2	0.65	0.7	0.75
All Dimensions in mm			

### 8. SOLDERING FOOTPRINT

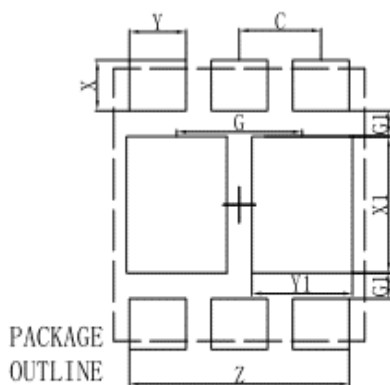

Dimensions	(mm)
X	0.37
Y	0.45
X1	1.00
Y1	0.80
C	0.65
G	1.00
G1	0.19
Z	1.75
C	0.65

## **DISCLAIMER**

- Before you use our Products, you are requested to carefully read this document and fully understand its contents. LRC shall not be in any way responsible or liable for failure, malfunction or accident arising from the use of any LRC's Products against warning, caution or note contained in this document.
- All information contained in this document is current as of the issuing date and subject to change without any prior notice. Before purchasing or using LRC's Products, please confirm the latest information with a LRC sales representative.