

LN2610ST1G

60V N-Channel (D-S) MOSFET

1. FEATURES

- Low RDS(on) trench technology.
- Low thermal impedance.
- Fast switching speed.
- We declare that the material of product are Halogen Free and compliance with RoHS requirements.

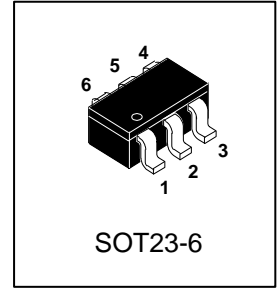

2. APPLICATION

- Power Routing
- DC/DC Conversion
- Motor Drives

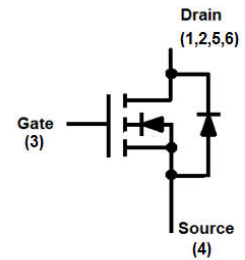

3. ORDERING INFORMATION

Device	Marking	Shipping
LN2610ST1G	NS1	3000/Tape&Reel

4. MAXIMUM RATINGS(Ta = 25°C unless otherwise stated)

Parameter		Symbol	Limits	Unit
Drain-to-Source Voltage		VDSS	60	V
Gate-to-Source Voltage		VGS	±20	V
Continuous Drain Current	TA =25°C	ID	4.4	A
	TA =70°C		3.8	
Pulsed Drain Current (Note 1)		IDM	17	A
Avalanche Current(L=0.1mH)		IAS	8	A
Avalanche Energy(L=0.1mH)		EAS	3.2	mJ
Power Dissipation TA =25°C		PD	1.2	W
Operating Junction and Storage Temperature Range		TJ , TSTG	-55 ~+150	°C

1.Pulse width limited by maximum junction temperature.

5. THERMAL CHARACTERISTICS

Parameter	Symbol	Limits	Unit
Thermal Resistance,Junction-to-Ambient (Note 2)	RθJA	105	°C/W
Thermal Resistance,Junction-to-Case (Note 2)	RθJC	30	°C/W

2.Surface mounted on "1.5 x 1.5" FR4 board using 1 sq in pad, 2 oz Cu.

6. ELECTRICAL CHARACTERISTICS (Ta= 25°C)

Characteristic	Symbol	Min.	Typ.	Max.	Unit
Static					
Drain to Source Breakdown Voltage (VGS = 0V, ID = 250μA)	V(BR)DSS	60	-	-	V
Gate-Source Threshold Voltage (VDS = VGS, ID = 250 uA)	VGS(th)	1	2	3	V
Gate-Body Leakage (VDS = 0 V, VGS = ±20 V)	IGSS	-	-	±100	nA
Zero Gate Voltage Drain Current (VDS = 60 V, VGS = 0 V)	IDSS	-	-	1	μA
Drain-Source On-Resistance(Note 3) (VGS = 10 V, ID = 3 A) (VGS = 5 V, ID = 3 A)	RDS(on)	- -	- -	60 75	mΩ
Diode Forward Voltage(Note 3) (VGS=0V, IS=1A)	VSD	-	-	1.2	V
Dynamic					
Total Gate Charge	(VDS = 30 V, VGS = 10 V, ID = 3A)	Qg	-	12	nC
Gate-Source Charge		Qgs	-	1.6	
Gate-Drain Charge		Qgd	-	3	
Turn-On Delay Time	(VDS = 30V, ID=1A, VGS = 10V RG = 6 Ω)	td(on)	-	10	ns
Rise Time		tr	-	12	
Turn-Off Delay Time		td(off)	-	20	
Fall Time		tf	-	15	
Input Capacitance	(VDS = 30 V, VGS = 0 V, f = 1 MHz)	Ciss	-	609	pF
Output Capacitance		Coss	-	38	
Reverse Transfer Capacitance		Crss	-	28	

3. Pulse test: PW ≤ 300us duty cycle ≤ 2%.

7. ELECTRICAL CHARACTERISTICS CURVES

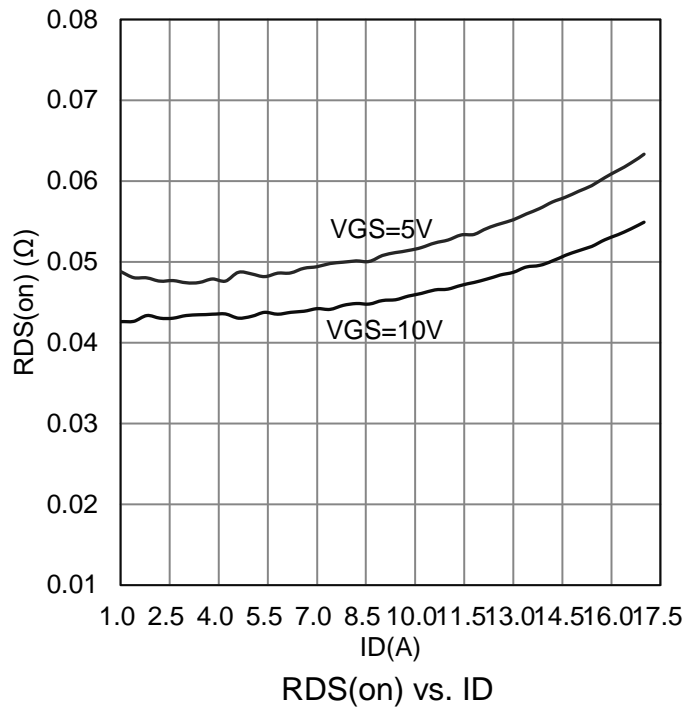
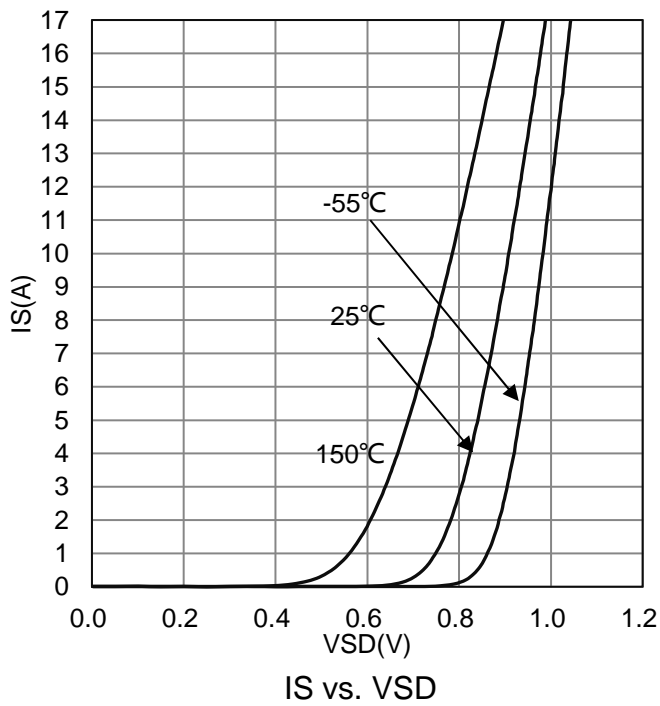
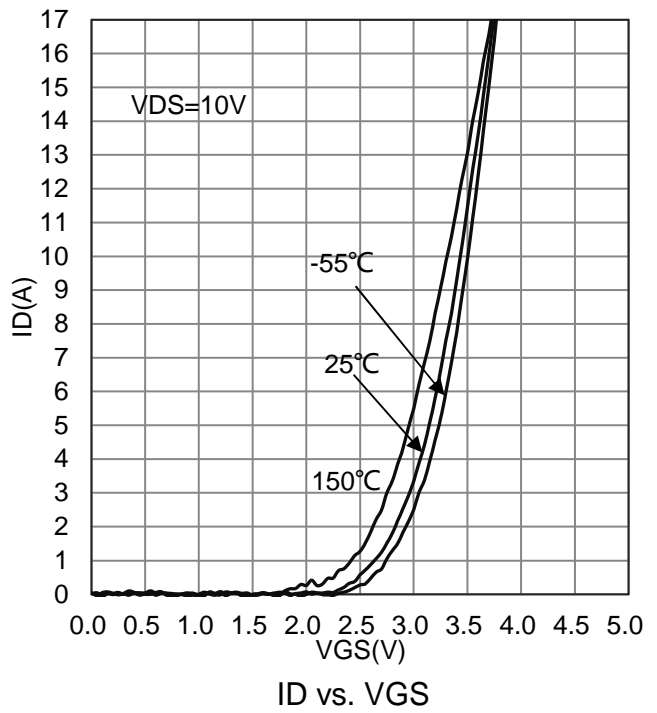
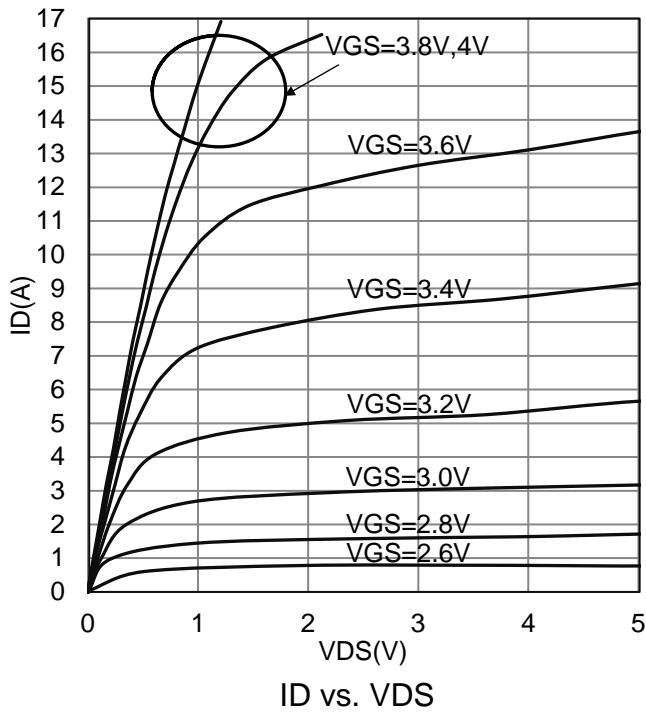

7. ELECTRICAL CHARACTERISTICS CURVES(Con.)

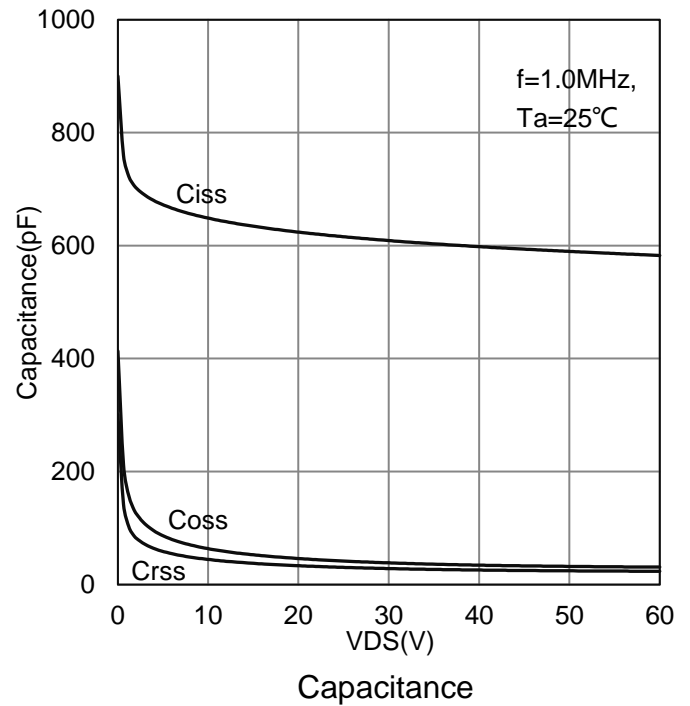
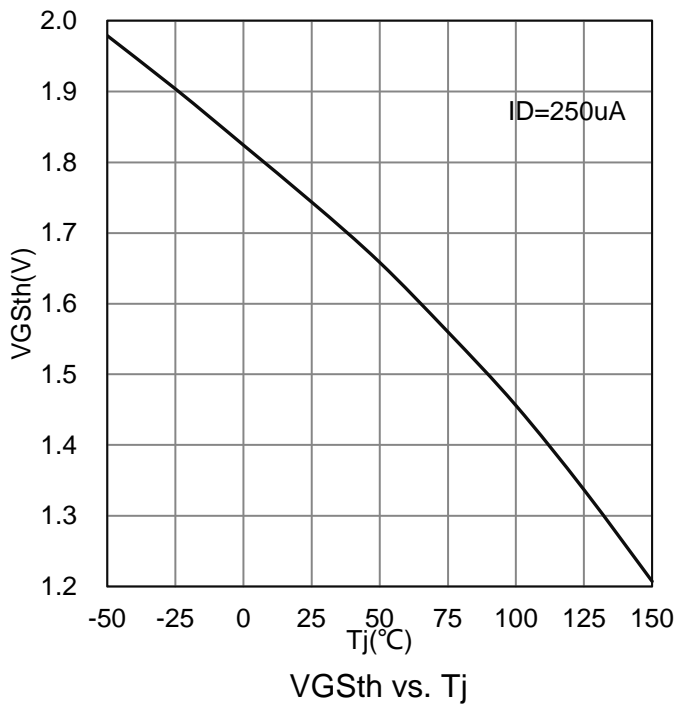
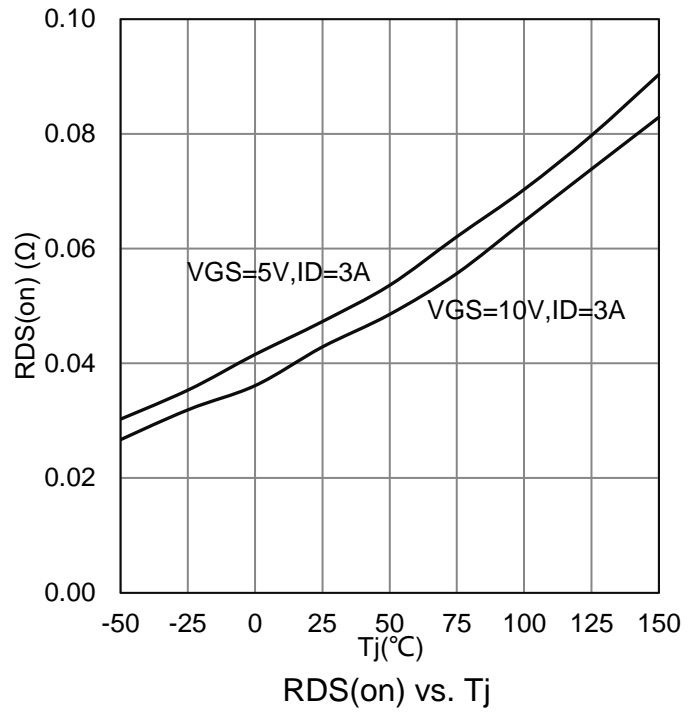
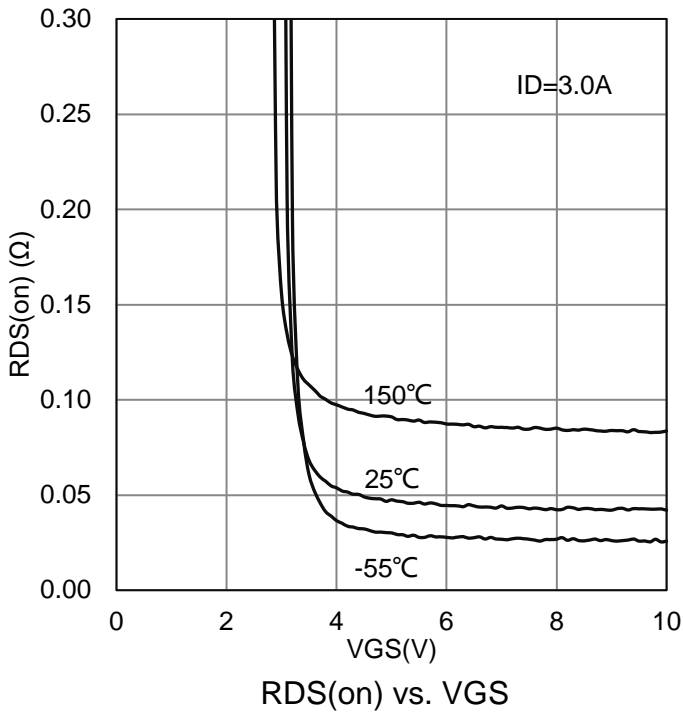

8. OUTLINE AND DIMENSIONS

SOT23-6

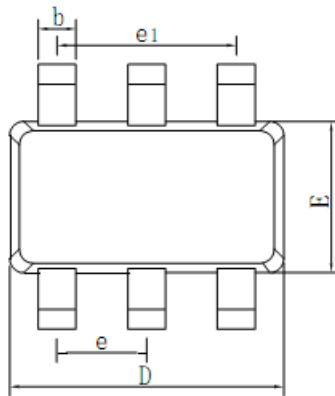
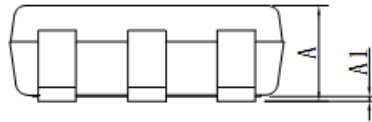
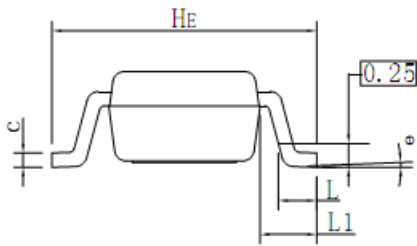

SOT23-6			
DIM	MIN	NOR	MAX
A	0.90	1.00	1.10
A1	0.01	0.06	0.10
b	0.25	0.40	0.50
c	0.10	0.17	0.26
D	2.80	2.90	3.10
E	1.30	1.60	1.70
e	0.85	0.95	1.05
e1	1.80	1.90	2.00
L	0.20	0.40	0.60
L1	0.60REF		
HE	2.50	2.80	3.00
θ	0°	-	10°

9. SOLDERING FOOTPRINT

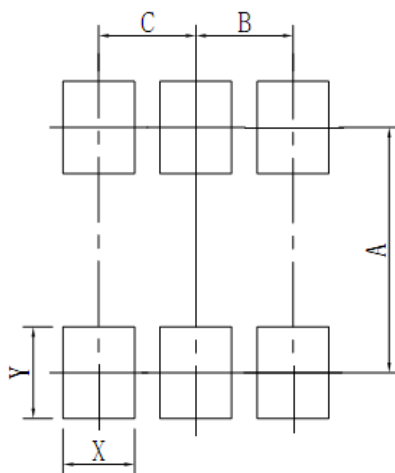

SOT23-6	
DIM	(mm)
X	0.70
Y	0.90
A	2.40
B	0.95
C	0.95

DISCLAIMER

- Before you use our Products, you are requested to carefully read this document and fully understand its contents. LRC shall not be in any way responsible or liable for failure, malfunction or accident arising from the use of any LRC's Products against warning, caution or note contained in this document.
- All information contained in this document is current as of the issuing date and subject to change without any prior notice. Before purchasing or using LRC's Products, please confirm the latest information with a LRC sales representative.