

isc Silicon NPN Darlington Power Transistor
2SD2493
DESCRIPTION

- Collector-Emitter Breakdown Voltage-
: $V_{(BR)CEO} = 110V(\text{Min})$
- High DC Current Gain-
: $h_{FE} = 5000(\text{Min.}) @ (I_C = 5A, V_{CE} = 4V)$
- Low Collector Saturation Voltage-
: $V_{CE(sat)} = 2.5V(\text{Max}) @ (I_C = 5A, I_B = 5mA)$
- Complement to Type 2SB1624
- Minimum Lot-to-Lot variations for robust device performance and reliable operation

APPLICATIONS

- Designed for audio, series regulator and general purpose applications.

ABSOLUTE MAXIMUM RATINGS($T_a = 25^\circ\text{C}$)

SYMBOL	PARAMETER	VALUE	UNIT
V_{CBO}	Collector-Base Voltage	110	V
V_{CEO}	Collector-Emitter Voltage	110	V
V_{EBO}	Emitter-Base Voltage	5	V
I_C	Collector Current-Continuous	6	A
I_B	Base Current-Continuous	1	A
P_C	Collector Power Dissipation @ $T_C = 25^\circ\text{C}$	60	W
T_J	Junction Temperature	150	$^\circ\text{C}$
T_{stg}	Storage Temperature	-55~150	$^\circ\text{C}$

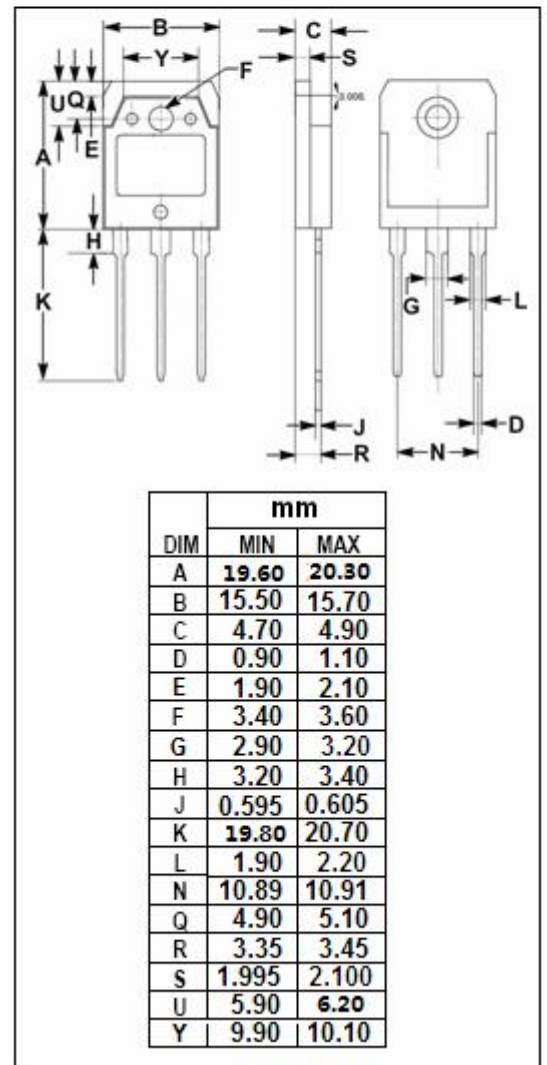
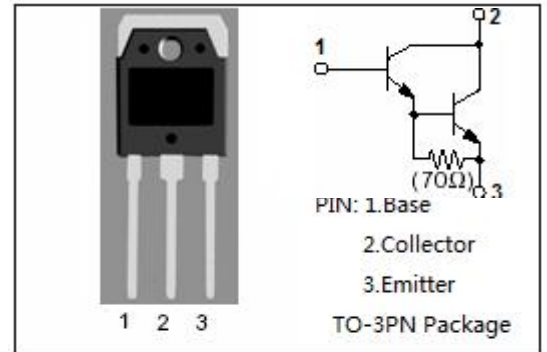

isc Silicon NPN Darlington Power Transistor

2SD2493

ELECTRICAL CHARACTERISTICS

T_j=25°C unless otherwise specified

SYMBOL	PARAMETER	CONDITIONS	MIN	TYP.	MAX	UNIT
V _{(BR)CEO}	Collector-Emitter Breakdown Voltage	I _C = 30mA ; I _B = 0	110			V
V _{CE(sat)}	Collector-Emitter Saturation Voltage	I _C = 5A; I _B = 5mA			2.5	V
V _{BE(sat)}	Base-Emitter Saturation Voltage	I _C = 5A; I _B = 5mA			3.0	V
I _{CBO}	Collector Cutoff Current	V _{CB} = 110V; I _E = 0			100	μ A
I _{EBO}	Emitter Cutoff Current	V _{EB} = 5V; I _C = 0			100	μ A
h _{FE}	DC Current Gain	I _C = 5A; V _{CE} = 4V	5000			
C _{OB}	Output Capacitance	I _E = 0; V _{CB} = 10V; f _{test} = 1MHz		55		pF
f _T	Current-Gain—Bandwidth Product	I _E = -2A ; V _{CE} = 12V		60		MHz

Switching Times

t _{on}	Turn-on Time	V _{CC} = 30V, R _L = 6 Ω, I _C = 5A; I _{B1} = -I _{B2} = 5mA,		0.8		μ s
t _{stg}	Storage Time			6.2		μ s
t _f	Fall Time			1.1		μ s

◆ h_{FE} Classifications

O	P	Y
5000-12000	6500-20000	15000-30000

NOTICE:

ISC reserves the rights to make changes of the content herein the datasheet at any time without notification. The information contained herein is presented only as a guide for the applications of our products.

ISC products are intended for usage in general electronic equipment. The products are not designed for use in equipment which require specialized quality and/or reliability, or in equipment which could have applications in hazardous environments, aerospace industry, or medical field. Please contact us if you intend our products to be used in these special applications.

ISC makes no warranty or guarantee regarding the suitability of its products for any particular purpose, nor does ISC assume any liability arising from the application or use of any products, and specifically disclaims any and all liability, including without limitation special, consequential or incidental damages.