

**isc Silicon NPN Darlington Power Transistor**
**2SD2340**
**DESCRIPTION**

- Collector-Emitter Breakdown Voltage-  
:  $V_{(BR)CEO} = 110V(\text{Min})$
- High DC Current Gain  
:  $h_{FE} = 5000(\text{Min}) @ I_C = 3A$
- Low Collector Saturation Voltage-  
:  $V_{CE(sat)} = 2.5V(\text{Max.}) @ I_C = 5A$
- Minimum Lot-to-Lot variations for robust device performance and reliable operation

**APPLICATIONS**

- Audio, regulator and general purpose.

**ABSOLUTE MAXIMUM RATINGS( $T_a = 25^\circ\text{C}$ )**

SYMBOL	PARAMETER	VALUE	UNIT
$V_{CBO}$	Collector-Base Voltage	130	V
$V_{CEO}$	Collector-Emitter Voltage	110	V
$V_{EBO}$	Emitter-Base Voltage	5	V
$I_C$	Collector Current-Continuous	6	A
$I_{CP}$	Collector Current-Peak	10	A
$P_C$	Collector Power Dissipation @ $T_a = 25^\circ\text{C}$	2.5	W
	Collector Power Dissipation @ $T_c = 25^\circ\text{C}$	50	
$T_J$	Junction Temperature	150	$^\circ\text{C}$
$T_{stg}$	Storage Temperature Range	-55~150	$^\circ\text{C}$

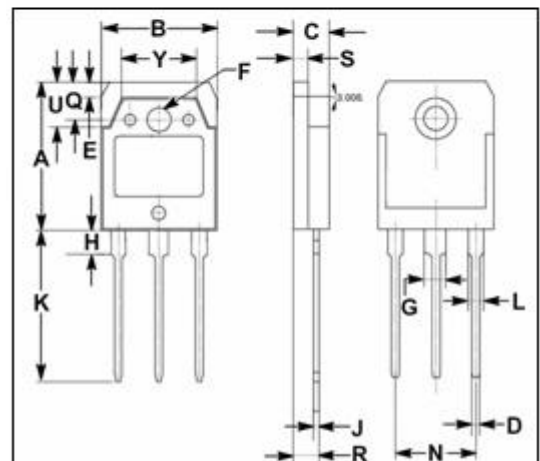
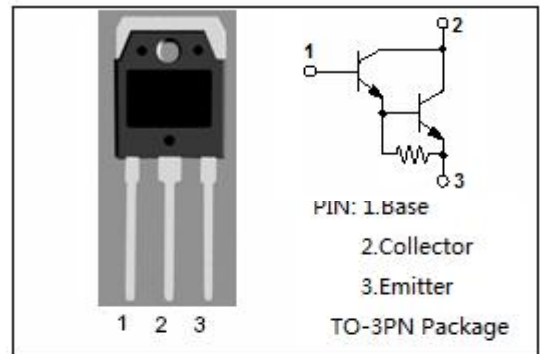

DIM	mm	
	MIN	MAX
A	19.60	20.30
B	15.50	15.70
C	4.70	4.90
D	0.90	1.10
E	1.90	2.10
F	3.40	3.60
G	2.90	3.20
H	3.20	3.40
J	0.595	0.605
K	19.80	20.70
L	1.90	2.20
N	10.89	10.91
Q	4.90	5.10
R	3.35	3.45
S	1.995	2.100
U	5.90	6.20
Y	9.90	10.10

**isc Silicon NPN Darlington Power Transistor****2SD2340****ELECTRICAL CHARACTERISTICS** $T_C=25^{\circ}\text{C}$  unless otherwise specified

SYMBOL	PARAMETER	CONDITIONS	MIN	TYP.	MAX	UNIT
$V_{(BR)CEO}$	Collector-Emitter Breakdown Voltage	$I_C=30\text{mA}; I_B=0$	110			V
$V_{(BR)CBO}$	Collector-Base Breakdown Voltage	$I_C=1\text{mA}; I_E=0$	130			V
$V_{CE(sat)}$	Collector-Emitter Saturation Voltage	$I_C=5\text{A}; I_B=5\text{mA}$			2.5	V
$V_{BE(sat)}$	Base-Emitter Saturation Voltage	$I_C=5\text{A}; I_B=5\text{mA}$			3.0	V
$I_{CBO}$	Collector Cutoff Current	$V_{CB}=130\text{V}; I_E=0$			100	$\mu\text{A}$
$I_{CEO}$	Collector Cutoff current	$V_{CE}=110\text{V}; I_B=0$			100	$\mu\text{A}$
$I_{EBO}$	Emitter Cutoff Current	$V_{EB}=5\text{V}; I_C=0$			3.0	mA
$h_{FE}$	DC Current Gain	$I_C=3\text{A}; V_{CE}=5\text{V}$	5000			
$f_T$	Current-Gain—Bandwidth Product	$I_C=0.5\text{A}; V_{CE}=10\text{V}$		20		MHz

## Switching times

$t_{on}$	Turn-on Time	$I_C=5\text{A}, I_{B1}=I_{B2}=5\text{mA}$		3.5		$\mu\text{s}$
$t_{stg}$	Storage Time			2.5		$\mu\text{s}$
$t_f$	Fall Time			0.6		$\mu\text{s}$

**NOTICE:**

ISC reserves the rights to make changes of the content herein the datasheet at any time without notification. The information contained herein is presented only as a guide for the applications of our products.

ISC products are intended for usage in general electronic equipment. The products are not designed for use in equipment which require specialized quality and/or reliability, or in equipment which could have applications in hazardous environments, aerospace industry, or medical field. Please contact us if you intend our products to be used in these special applications.

ISC makes no warranty or guarantee regarding the suitability of its products for any particular purpose, nor does ISC assume any liability arising from the application or use of any products, and specifically disclaims any and all liability, including without limitation special, consequential or incidental damages.