

High Efficiency, Low Noise, Ultra-Low Distortion, Constant Large Volume, Upgrade 7th-Generation Class K Audio Amplifier

FEATURES

- ◆ Speaker and Receiver two-in-one application
 - ◆ Class AB Receiver Mode: 1V/V, $V_n=11\mu\text{V}$, THD+N=0.15%
 - ◆ Class K Speaker Mode: 8V/V, $V_n=53\mu\text{V}$, THD+N=0.008%
- ◆ Power Amplifier's Overall Efficiency: 80%
- ◆ High PSRR: 100dB@217Hz
- ◆ Within Lithium Battery Voltage Range, Outputs Constant Large Volume
- ◆ Selectable Speaker-Guard Power Level: 0.6W, 0.8W, 1.0W, 1.2W
- ◆ Upgrade for AW87317
- ◆ No-Crack-Noise (NCN) Technology
- ◆ Super TDD-Noise Suppression
- ◆ Excellent Pop-Click Suppression
- ◆ One-Wire Pulse Control
- ◆ ESD Protection: $\pm 6\text{kV}$ (HBM)
- ◆ Small 1.575mm \times 1.575mm, 0.4mm Pitch CSP-14 Package

APPLICATIONS

- ◆ Smart Phones

DESCRIPTION

AW87327 is specifically designed to enhance overall sound quality. It is an upgrading 7th-generation class K audio amplifier with high efficiency, low noise, ultra-low distortion and capability of outputting constant large volume.

With integrated AWINIC proprietary NCN output AGC audio algorithm, AW87327 can eliminate noise in playback and improve sound quality and effect. Using a novel K-Chargepump technology, its integrated charge pump efficiency can reach 93%, and power amplifier's overall efficiency can reach 80%. With high efficiency, AW87327 can greatly prolong smart phone usage time.

AW87327 noise floor is as low as to $53\mu\text{V}$, with 97dB high signal-to-noise-ratio (SNR). The ultra-low distortion 0.008% brings high-quality musical enjoyment.

AW87327 has a setting of 4-step selectable speaker-guard output power level from 0.6W to 1.2W, suitable for different rated power speakers. Within lithium battery voltage range, it keeps output power constant, preventing voice from degrading.

AW87327 supports speaker and receiver two-in-one application. The Class AB Receiver Mode has an ultra-low output noise of $11\mu\text{V}$ and an ultra-high power supply noise suppression of -100dB@217Hz.

AW87327 has built-in over-current protection, over-temperature protection and short-circuit protection. AW87327 is available in a 1.575mm \times 1.575mm, 0.4mm pitch CSP-14 package.

APPLICATION DIAGRAM

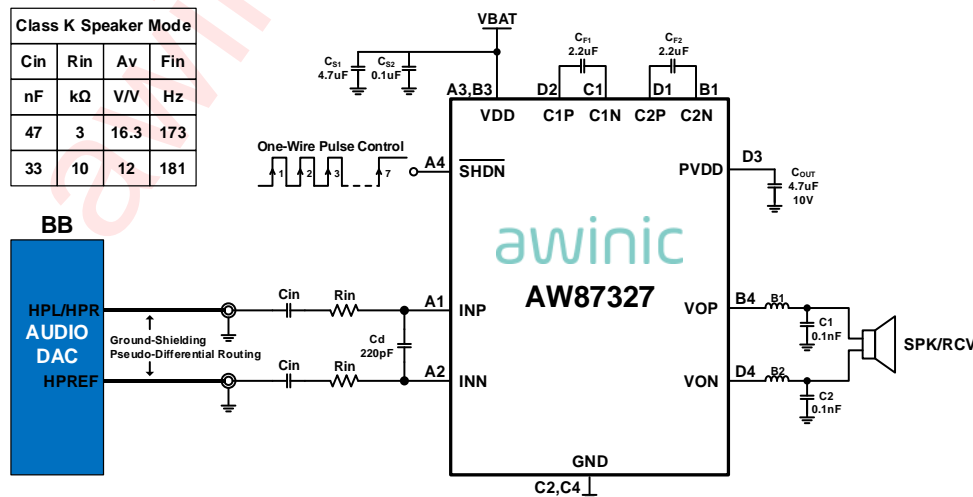

Figure 1 AW87327 Application Diagram

All trademarks are the property of their respective owner

PIN DIAGRAM AND DEVICE MARKING

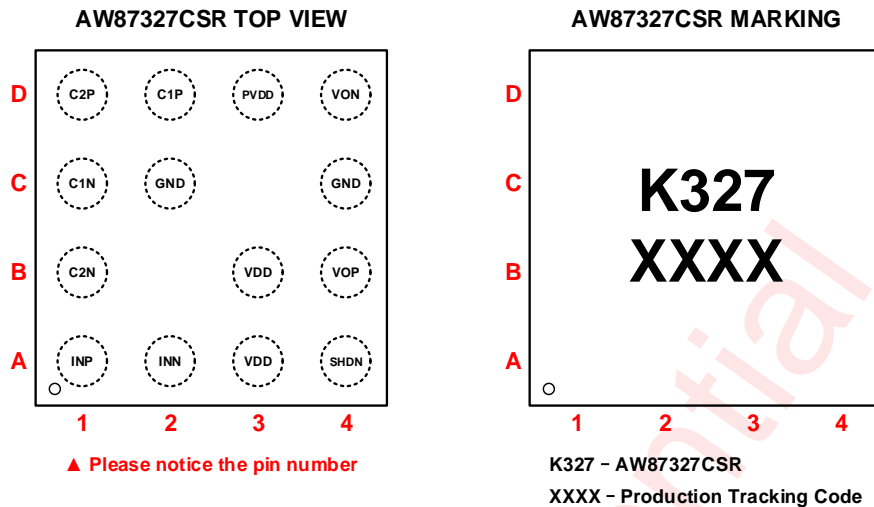

Figure 2 AW87327 Pin Diagram Top View and Device Marking

PIN DESCRIPTION

Number	Symbol	Description
A1	INP	Positive audio input
A2	INN	Negative audio input
A3, B3	VDD	Power supply
A4	SHDN	Chip power down pin, active low: one wire pulse control
B1	C2N	Negative terminal of the charge pump flying capacitor C_{F2}
B4	VOP	Positive audio output
C1	C1N	Negative terminal of the charge pump flying capacitor C_{F1}
C2, C4	GND	Ground
D1	C2P	Positive terminal of the charge pump flying capacitor C_{F2}
D2	C1P	Positive terminal of the charge pump flying capacitor C_{F1}
D3	PVDD	Charge pump output
D4	VON	Negative audio output

AWINIC CLASS K FAMILY

ITEM	TEST CONDITION	AW8737	AW87317	AW87327
PVDD (V)	VDD=4.2V	6.05	6.05	6.05
Output Noise (μ V)	VDD=4.2V, f=20Hz to 20kHz Input ac grounded, 8V/V, A-weighting	52	53	53
Efficiency (%)	VDD=3.6V, $P_o=1.0W$, $R_L=8\Omega+33\mu H$	80	80	80

FUNCTIONAL DIAGRAM

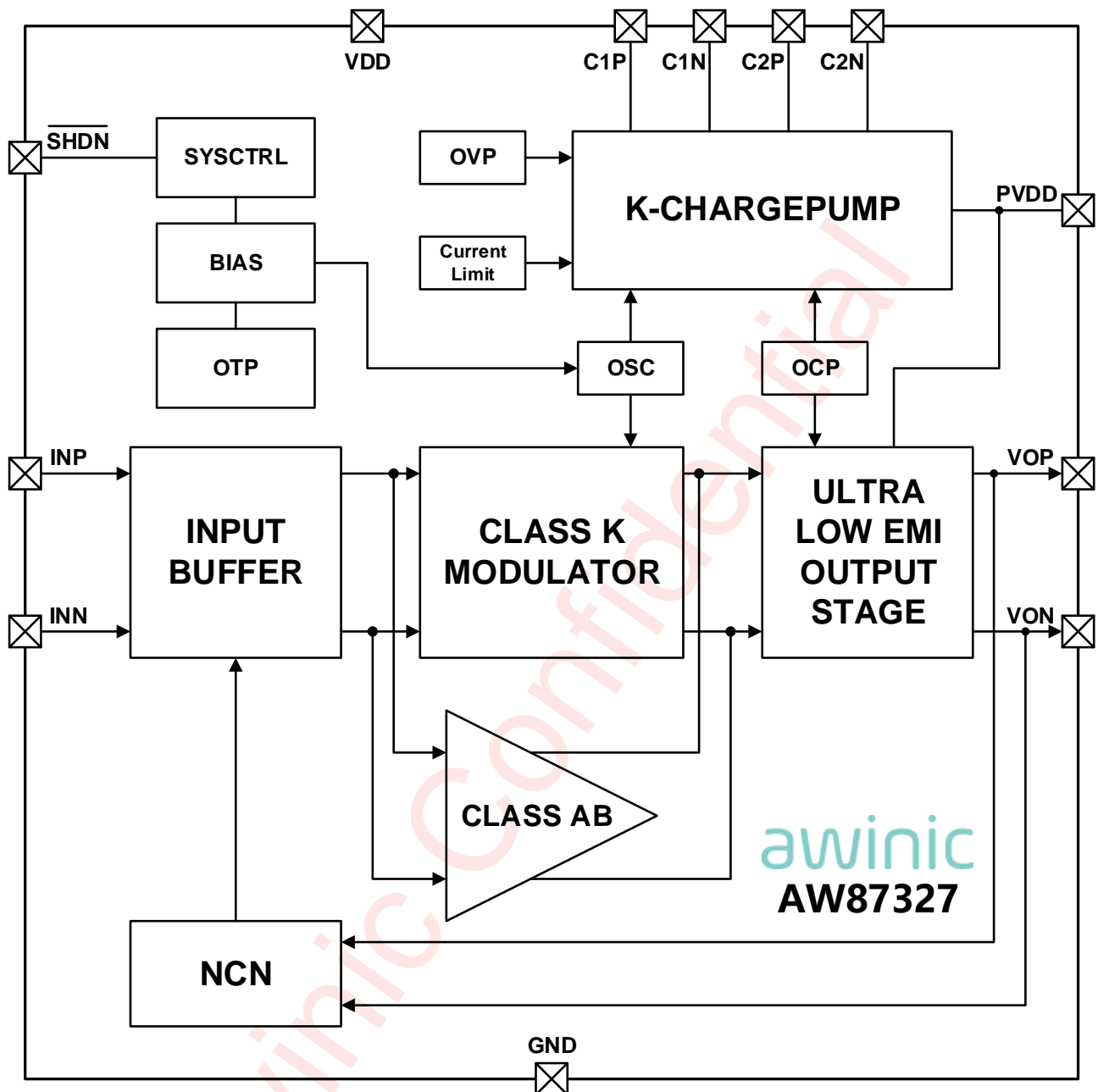

Figure 3 AW87327 Functional Diagram

APPLICATION DIAGRAM

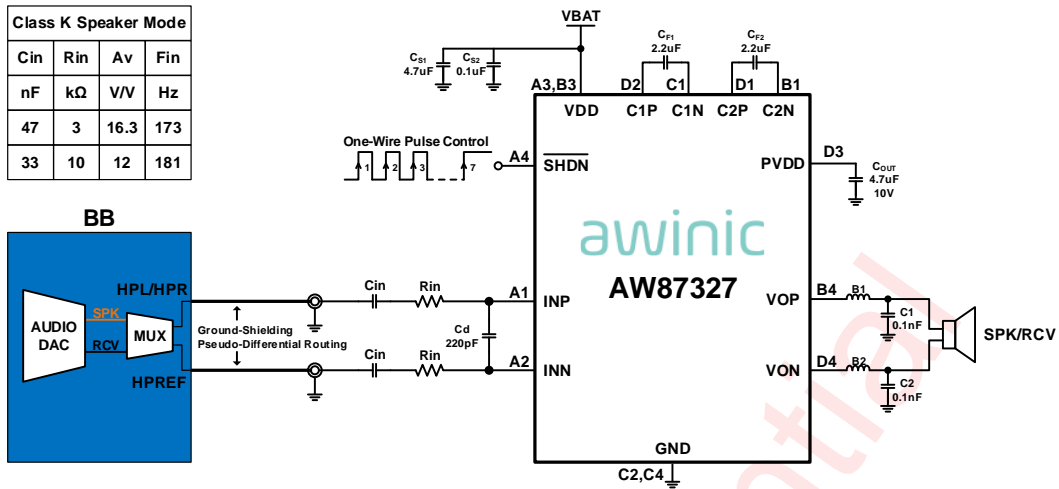

Figure 4 AW87327 Single-ended Input Speaker Mode Application Diagram (Note 1)

Note1: When single-ended input, audio signal line from audio DAC (HPL or HPR) can arbitrarily connected to either of INP or INN input terminal. The other terminal must be connected to reference ground (HPREF) through input capacitor and resistor.

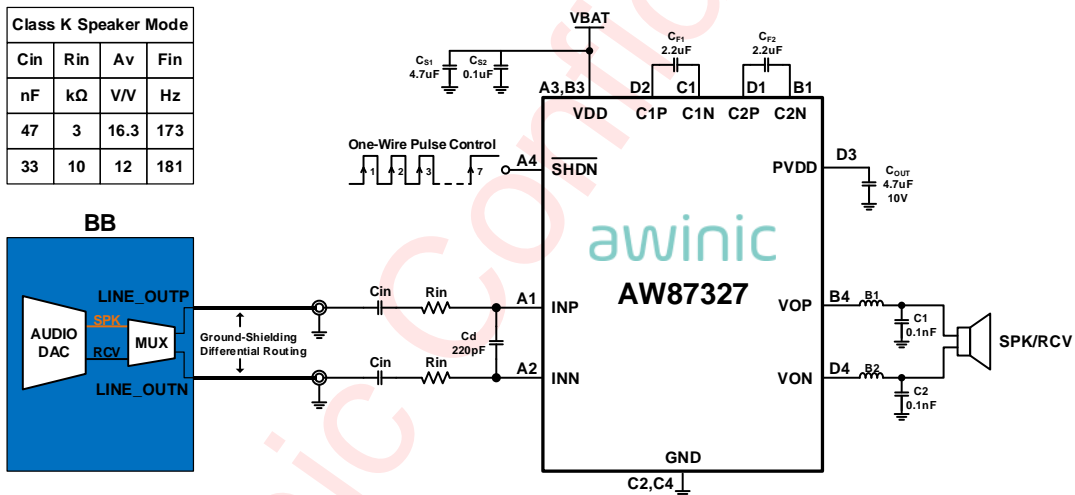

Figure 5 AW87327 Differential Input Speaker Mode Application Diagram

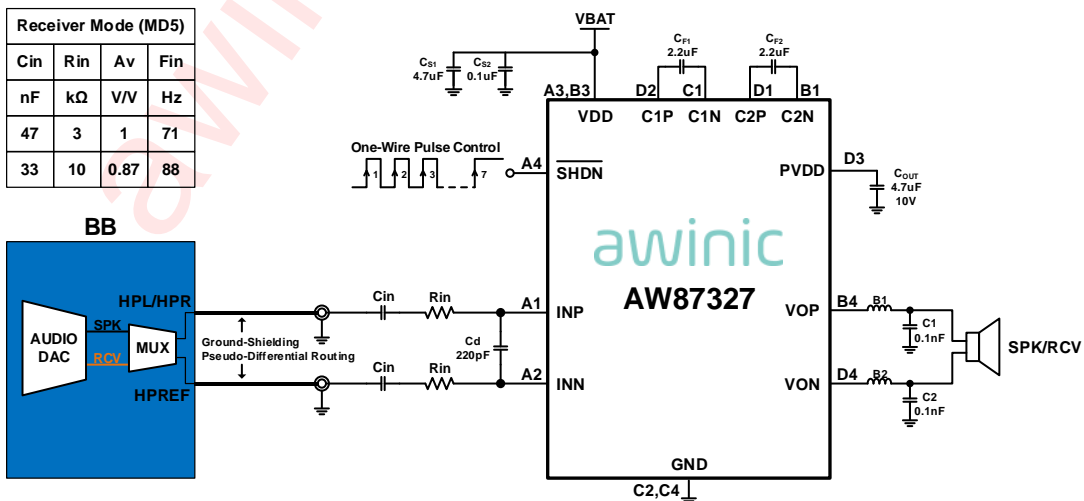

Figure 6 AW87327 Single-ended Input Receiver Mode Application Diagram

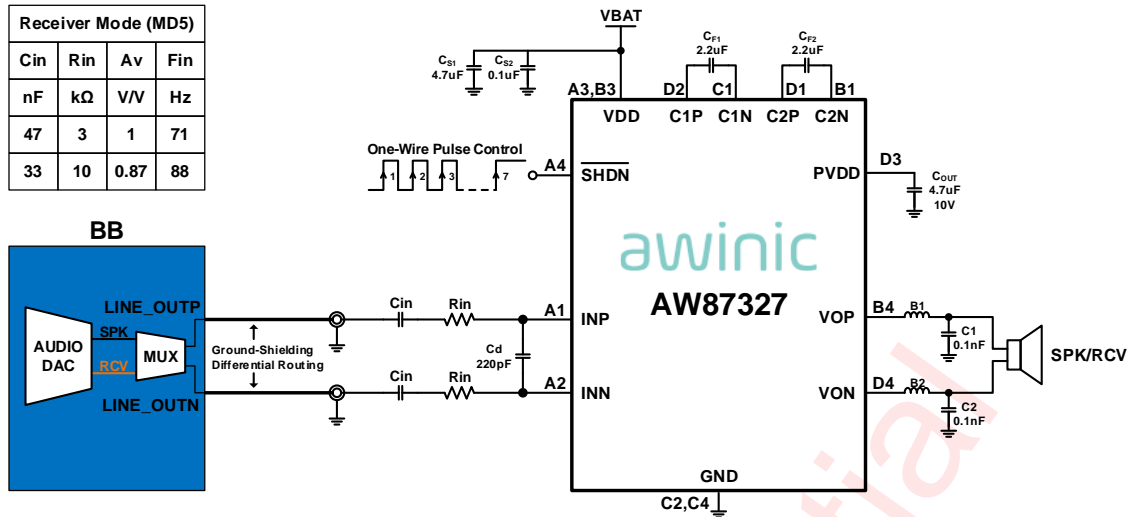
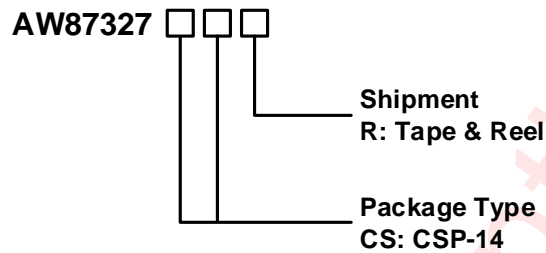

Figure 7 AW87327 Differential Input Receiver Mode Application Diagram

ORDERING INFORMATION

Product Type	Operation Temperature Range	Package	Device Marking	Moisture Sensitivity Level (MSL)	Environmental Information	Delivery Form
AW87327CSR	-40°C to 85°C	CSP-14	K327	MSL1	ROHS+HF	Tape & Reel 3000 pcs

ABSOLUTE MAXIMUM RATINGS^(NOTE2)

Parameter	Range
Power Supply VDD Voltage	-0.3V to 6V
Charge Pump Output PVDD Voltage	-0.3V to 7V
VOP, VON, C1P, C2P	-0.3V to PVDD+0.3V
C1N, C2N	-0.3V to VDD+0.3V
Input Pin INP, INN Voltage	-0.3V to VDD+0.3V
Junction-to-Ambient Thermal Resistance θ_{JA}	84.9°C/W
Operating Free-Air Temperature T_A	-40°C to 85°C
Maximum Junction Temperature T_{JMAX}	165°C
Storage Temperature T_{STG}	-65°C to 150°C
Lead Temperature (Soldering 10 Seconds)	260°C
ESD Rating	
Human Body Model (HBM) ^(Note 3)	±6kV
Charged Device Model (CDM) ^(Note 4)	±2kV
Latch-up	
Test Condition: JEDEC STANDARD NO.78E SEPTEMBER 2016	+IT: 450mA -IT: -450mA

Note 2: Stresses beyond those listed under "absolute maximum ratings" may cause permanent damage to the device. These are stress ratings only and functional operation of the device at these or any other conditions beyond those indicated under "recommended operating conditions" is not implied. Exposure to absolute-maximum-rated conditions for extended periods may affect device reliability.

Note 3: The human body model is a 100pF capacitor discharged through a 1.5kΩ resistor into each pin. Test method: MIL-STD-883J Method 3015.9.

Note 4: Test Method: ESDA/JEDEC JS-002-2014.

MODE DESCRIPTIONS ($T_A=25^{\circ}\text{C}$, $V_{DD}=4.2\text{V}$)

Under Speaker Mode (Mode 1 to Mode 4, and Mode 7) or Receiver Mode (Class AB Receiver Mode, Mode 8 and Mode 9), audio signal is inserted through INP & INN pins. The AW87327 external input capacitor is C_{in} and the external input resistor is R_{in} .

- Under Speaker Mode, the internal input resistor is $16.6\text{k}\Omega$. The gain of AW87327 (A_v) can be calculated by $319.5\text{k}/(R_{in}+16.6\text{k})$ (R_{in} unit: Ω). Recommended operating external setting is: $C_{in}=47\text{nF}$, $R_{in}=3\text{k}\Omega$, $A_v=16.3\text{V/V}$ or $R_{in}=10\text{k}\Omega$, $A_v=12\text{V/V}$.
- Under Class AB Receiver Mode, the internal input resistor is $45\text{k}\Omega$ under both Mode 5 and Mode 6. The gain of AW87327 (A_v) can be calculated by $48\text{k}/(R_{in}+45\text{k})$ (R_{in} unit: Ω) under Mode 5 and $144\text{k}/(R_{in}+45\text{k})$ (R_{in} unit: Ω) under Mode 6, respectively. Recommended operating external setting is: $C_{in}=47\text{nF}$, $R_{in}=3\text{k}\Omega$, $A_v=1\text{V/V}$ (Mode 5) and $A_v=3\text{V/V}$ (Mode 6).

The operating modes of AW87327 are listed below:

MODE	Enable Signal (SHDN)	Gain (V/V)		NCN Power Level (W)		NCN Function	Class AB Receiver Mode
		$R_{in}=3\text{k}\Omega$	$R_{in}=10\text{k}\Omega$	$R_L=8\Omega$ $+33\mu\text{H}$	$R_L=6\Omega$ $+33\mu\text{H}$		
1		16.3	12	1.2	1.6	√	
2		16.3	12	1.0	1.3	√	
3		16.3	12	0.8	1.0	√	
4		16.3	12	0.6	0.8	√	
5		1	0.9				√
6		3	2.6				√
7		16.3	12	1.75W@ THD=1%	2.05W@ THD=1%		

ELECTRICAL CHARACTERISTICS

Test condition: $T_A=25^{\circ}\text{C}$, $V_{DD}=3.6\text{V}$, $R_L=8\Omega+33\mu\text{H}$, $f=1\text{kHz}$ (unless otherwise noted)

Parameter		Test Conditions	Min	Typ	Max	Unit
V_{DD}	Power supply voltage		3.0		5.5	V
V_{IH}	$\overline{\text{SHDN}}$ high input voltage		1.3		V_{DD}	V
V_{IL}	$\overline{\text{SHDN}}$ low input voltage		0		0.45	V
$ V_{OS} $	Output offset voltage	$V_{IN}=0\text{V}$, $V_{DD}=3.0\text{V}$ to 5.5V	-30	0	30	mV
I_{SD}	Shutdown current	$V_{DD}=3.6\text{V}$, $\overline{\text{SHDN}}=0\text{V}$			2	μA
T_{TG}	Thermal AGC start temperature threshold			150		$^{\circ}\text{C}$
T_{TGR}	Thermal AGC exit temperature threshold			130		$^{\circ}\text{C}$
T_{SD}	Over temperature protection threshold			160		$^{\circ}\text{C}$
T_{SDR}	Over temperature protection recovery threshold			120		$^{\circ}\text{C}$
T_{ON}	Start-up time			40		ms
K-Chargepump						
PVDD	Output voltage	$V_{DD}=3.0\text{V}$ to 4V		$1.5\times V_{DD}$		V
		$V_{DD}>4\text{V}$		6.05		V
V _{hys}	OVP hysteresis voltage	$V_{DD}>4\text{V}$		50		mV
F_{CP}	Charge pump frequency	$V_{DD}=3.0\text{V}$ to 5.5V	0.79	1.06	1.33	MHz
η_{CP}	Charge pump efficiency	$V_{DD}=3.6\text{V}$, $I_{load}=200\text{mA}$		93		%
T_{ST}	Soft-start time	No load, $C_{OUT}=4.7\mu\text{F}$	1.0	1.2	1.4	ms
I_L	Current limit when PVDD short to ground		200	300	400	mA
Class K power amplifier (Mode1 to Mode4, and Mode7)						
I_q	Quiescent current	$V_{DD}=4.2\text{V}$, $V_{in}=0$, no load		10	15	mA
η	Efficiency	$V_{DD}=3.6\text{V}$, $P_o=1.0\text{W}$, $R_L=8\Omega+33\mu\text{H}$		80		%
F _{osc}	Modulation frequency	$V_{DD}=3.0\text{V}$ to 5.5V	600	800	1000	kHz
A _v	Gain	External input resistance=3k Ω		16.3		V/V
V _{in}	Recommended max input voltage	$V_{DD}=3.0\text{V}$ to 5.5V			1	V _p
R _{in}	Internal input resistor	Mode1 to Mode4, and Mode7		16.6		k Ω
F _{hin}	Input high pass filter corner frequency	$C_{in}=47\text{nF}$, external input resistor=3k Ω		173		Hz
P _{agc}	Mode1 NCN output AGC power	$V_{DD}=4.2\text{V}$, $R_L=8\Omega+33\mu\text{H}$	1.08	1.2	1.32	W
		$V_{DD}=4.2\text{V}$, $R_L=6\Omega+33\mu\text{H}$	1.44	1.6	1.76	W
	Mode2 NCN output AGC power	$V_{DD}=4.2\text{V}$, $R_L=8\Omega+33\mu\text{H}$	0.9	1	1.1	W
		$V_{DD}=4.2\text{V}$, $R_L=6\Omega+33\mu\text{H}$	1.17	1.3	1.43	W
	Mode3 NCN output AGC power	$V_{DD}=4.2\text{V}$, $R_L=8\Omega+33\mu\text{H}$	0.72	0.8	0.88	W
		$V_{DD}=4.2\text{V}$, $R_L=6\Omega+33\mu\text{H}$	0.9	1	1.1	W
Mode4 NCN output AGC power	$V_{DD}=4.2\text{V}$, $R_L=8\Omega+33\mu\text{H}$	0.54	0.6	0.66	W	
	$V_{DD}=4.2\text{V}$, $R_L=6\Omega+33\mu\text{H}$	0.72	0.8	0.88	W	

Parameter		Test Conditions		Min	Typ	Max	Unit
PSRR	Power supply rejection ratio	$V_{DD}=4.2V$, $V_{p-p_sin}=200mV$	217Hz		68		dB
			1kHz		68		dB
SNR	Signal-to-noise ratio	$V_{DD}=4.2V$, $P_o=1.75W$, THD+N=1%, $R_L=8\Omega+33\mu H$ $A_v=8V/V$			97		dB
V_n	Output noise voltage	$V_{DD}=4.2V$, $f=20Hz$ to 20kHz, input ac grounded, A-weighting	$A_v=8V/V$		53		μV_{rms}
			$A_v=12V/V$		58		μV_{rms}
			$A_v=16V/V$		68		μV_{rms}
THD+N	Total harmonic distortion+noise	$V_{DD}=3.6V$, $P_o=1W$, $R_L=8\Omega+33\mu H$, $f=1kHz$, Mode10			0.008		%
		$V_{DD}=3.6V$, $P_o=1W$, $R_L=6\Omega+33\mu H$, $f=1kHz$, Mode10			0.008		%
P_o	Mode7 output power	THD+N=10%, $f=1kHz$, $R_L=8\Omega+33\mu H$, $V_{DD}=4.2V$			2.15		W
		THD+N=1%, $f=1kHz$, $R_L=8\Omega+33\mu H$, $V_{DD}=4.2V$			1.75		W
		THD+N=10%, $f=1kHz$, $R_L=8\Omega+33\mu H$, $V_{DD}=3.6V$			1.6		W
		THD+N=1%, $f=1kHz$, $R_L=8\Omega+33\mu H$, $V_{DD}=3.6V$			1.28		W
		THD+N=10%, $f=1kHz$, $R_L=6\Omega+33\mu H$, $V_{DD}=4.2V$			2.52		W
		THD+N=1%, $f=1kHz$, $R_L=6\Omega+33\mu H$, $V_{DD}=4.2V$			2.05		W
		THD+N=10%, $f=1kHz$, $R_L=6\Omega+33\mu H$, $V_{DD}=3.6V$			1.82		W
		THD+N=1%, $f=1kHz$, $R_L=6\Omega+33\mu H$, $V_{DD}=3.6V$			1.5		W
Class AB Receiver (Mode5 and Mode6)							
I_q	Quiescent current	$V_{DD}=4.2V$, $V_{IN}=0$, no load			7		mA
η	Efficiency	$V_{DD}=3.6V$, $P_o=0.4W$, $R_L=8\Omega+33\mu H$, Mode6			69		%
A_v	Gain	External input resistor=3k Ω , Mode5			1		V/V
		External input resistor=3k Ω , Mode6			3		V/V
R _{in}	Internal input resistor	Mode5 & Mode6			45		k Ω
P_o	Mode 5, single-ended input	THD+N=1%, $f=1kHz$, $R_L=8\Omega+33\mu H$, $V_{DD}=3.6V$			250		mW
	Mode 5, differential input	THD+N=1%, $f=1kHz$, $R_L=8\Omega+33\mu H$, $V_{DD}=3.6V$			450		mW
	Mode 6	THD+N=1%, $f=1kHz$, $R_L=8\Omega+33\mu H$, $V_{DD}=3.6V$			450		mW
F_{hin}	Input high pass filter corner frequency	$C_{in}=47nF$, external input resistor=3k Ω , Mode5			71		Hz
		$C_{in}=47nF$, external input resistor=3k Ω , Mode6			71		Hz
PSRR	Power supply rejection ratio	$V_{DD}=4.2V$, $V_{p-p_sin}=800mV$, Mode5	217Hz		100		dB
			1kHz		100		dB
V_n	Output noise voltage	$V_{DD}=4.2V$, $f=20Hz$ to 20kHz, input ac grounded, A-weighting	$A_v=1V/V$		11		μV_{rms}
			$A_v=3V/V$		26		μV_{rms}
THD+N	Total harmonic distortion+noise	$V_{DD}=4.2V$, $R_L=8\Omega+33\mu H$, $f=1kHz$	$P_o=0.1W$, Mode5		0.15		%
			$P_o=0.3W$, Mode6		0.15		%
One Wire Pulse Control							
T_H	\overline{SHDN} high level duration time	$V_{DD}=3.0V$ to 5.5V		0.75	2	10	μs
T_L	\overline{SHDN} low level duration time	$V_{DD}=3.0V$ to 5.5V		0.75	2	10	μs
T_{LATCH}	\overline{SHDN} turn on delay time	$V_{DD}=3.0V$ to 5.5V		150		500	μs
T_{OFF}	\overline{SHDN} turn off delay time	$V_{DD}=3.0V$ to 5.5V		150		500	μs
NCN (Note 5)							
T_{AT}	Attack time	-13.5dB gain attenuation completed			40		ms

Parameter		Test Conditions	Min	Typ	Max	Unit
T_{RL}	Release time	13.5dB gain release completed		1.2		s
A_{MAX}	Maximum attenuation			-13.5		dB

Note 5: Attack Time refers to the duration of gain attenuation by 13.5dB. Similarly, Release Time refers to the duration of gain recovery by 13.5dB.

awinic Confidential

MEASUREMENT SETUP

AW87327 features switching digital output, as shown in Figure 8. It is crucial to connect a low pass filter after VOP/VON outputs, respectively, to filter out switch modulation frequency, then measure the differential output of filter to obtain audio analog output signal.

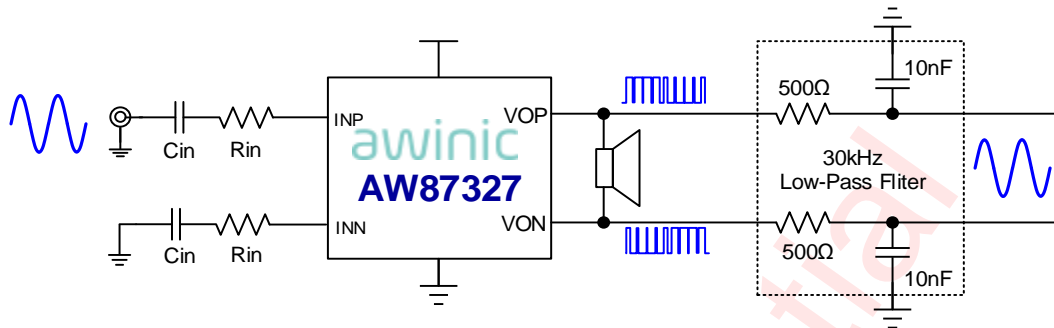

Figure 8 AW87327 Test Setup

The values of resistor and capacitor used by low pass filter are listed below:

R_{filter}	C_{filter}	Low-pass cutoff frequency
500Ω	10nF	32kHz
1kΩ	4.7nF	34kHz

Output Power Calculation

According to the above test method, the differential audio analog output signal is obtained at the output of the low pass filter. The valid value V_{o_rms} of the differential signal is as shown below:

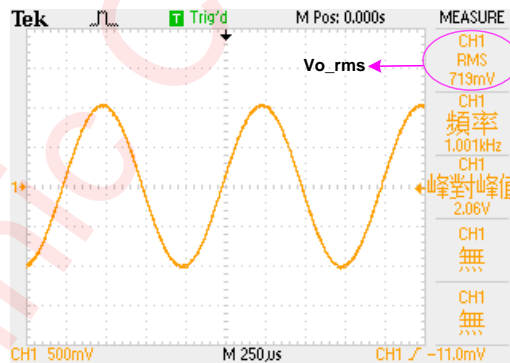

The power calculation of Speaker is as follows:

$$P_L = \frac{V_{O_RMS}^2}{R_L}$$

(R_L : Load Impedance of the speaker or receiver)

TYPICAL CHARACTERISTICS

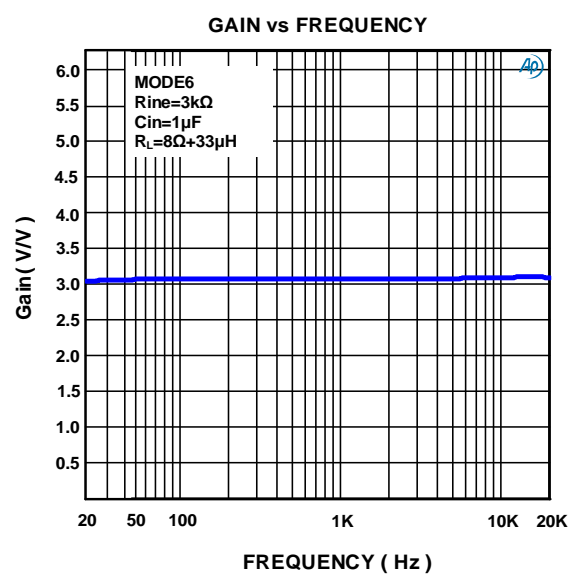
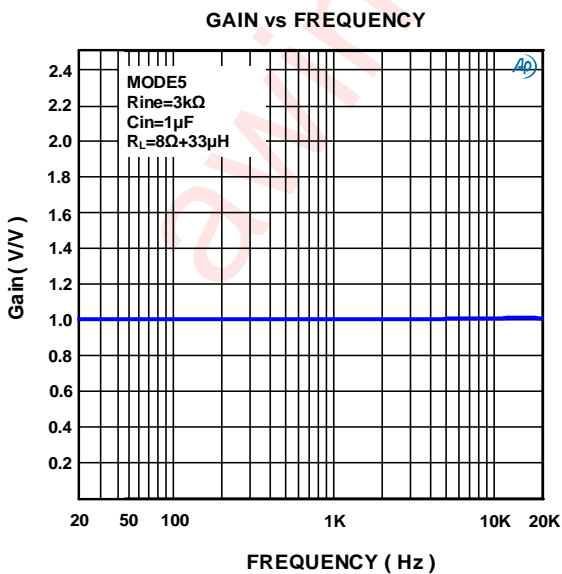
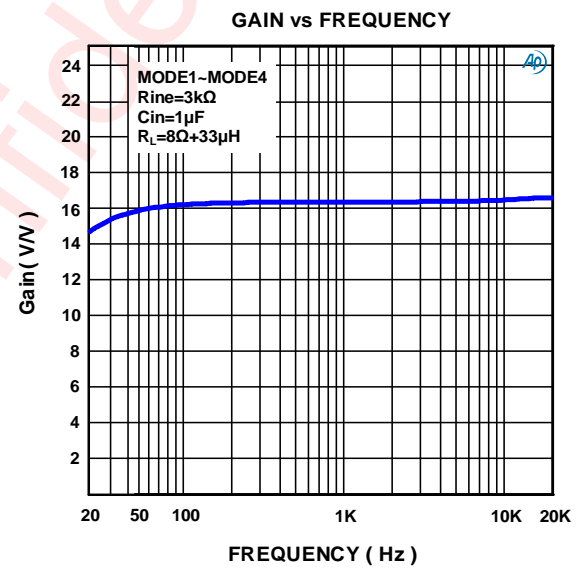
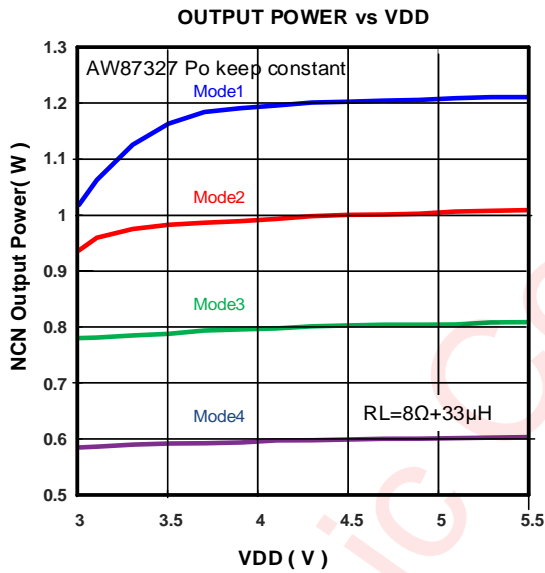
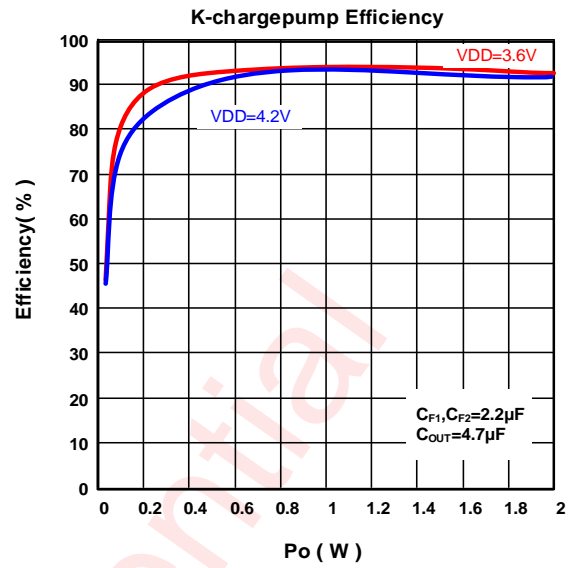
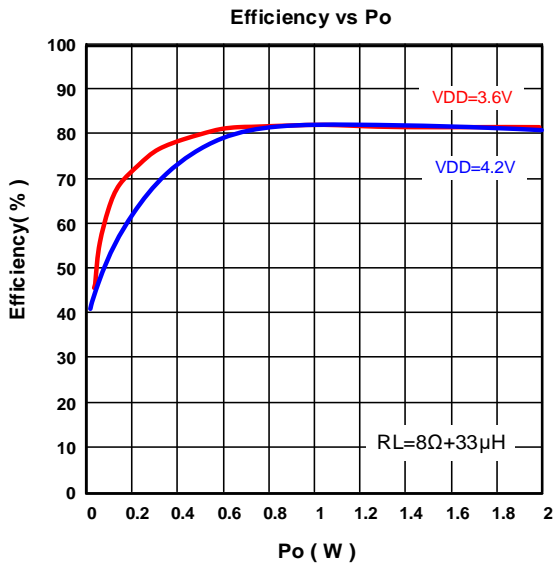

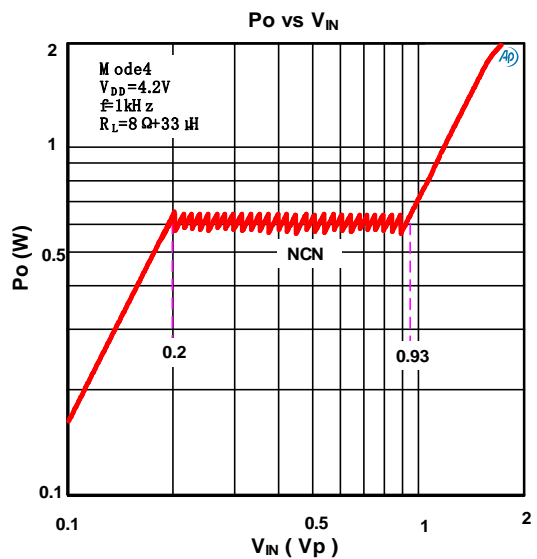
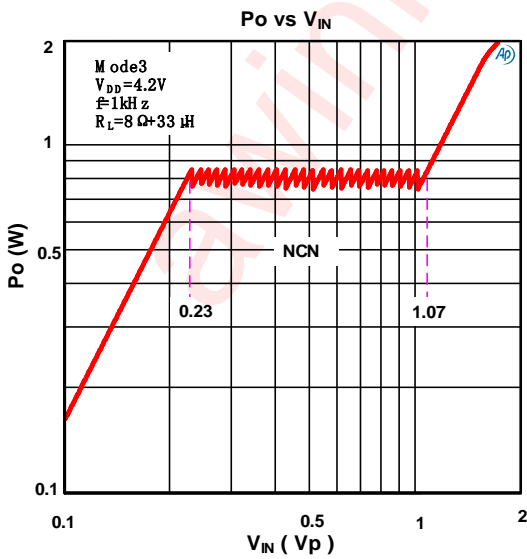
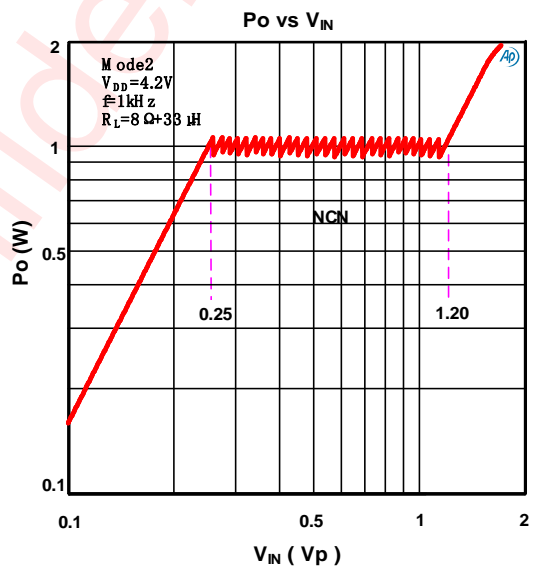
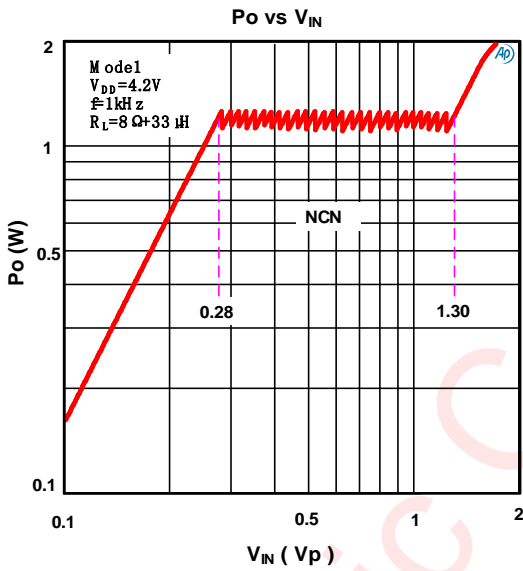
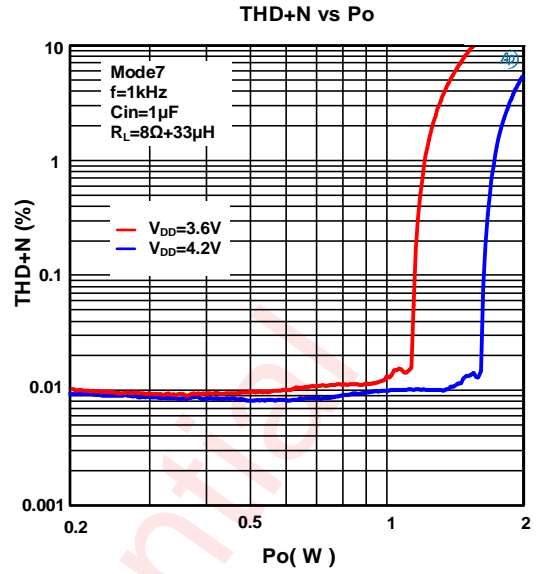
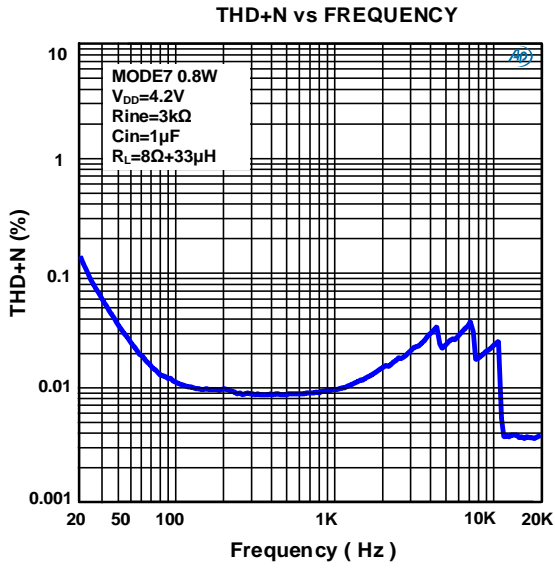

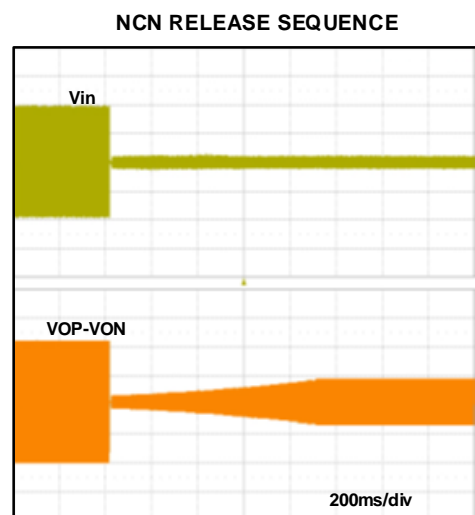
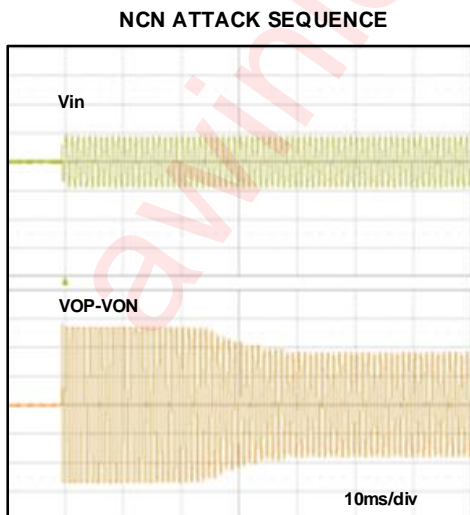
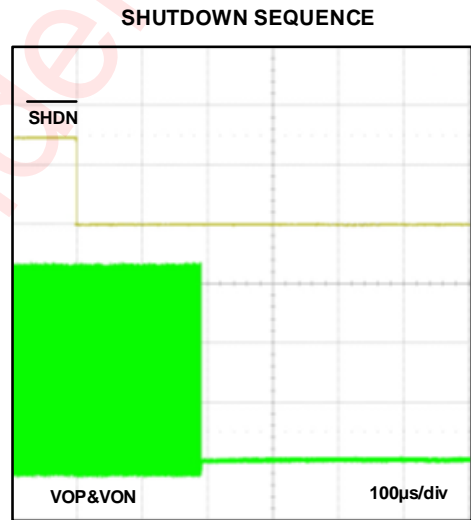
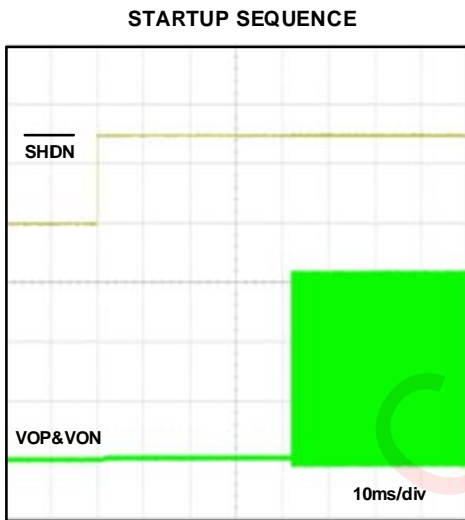
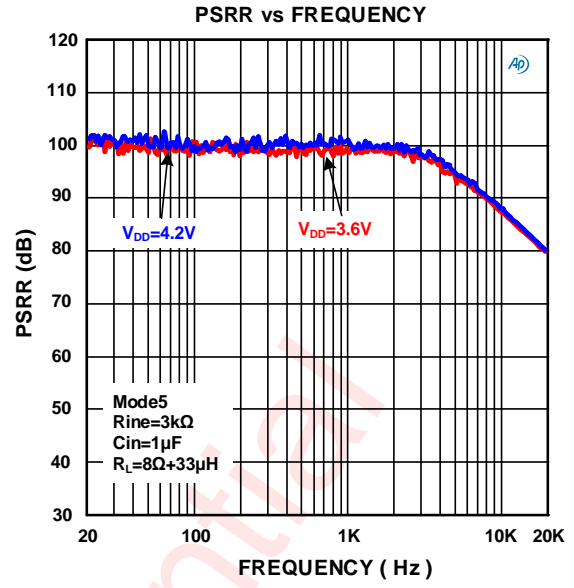
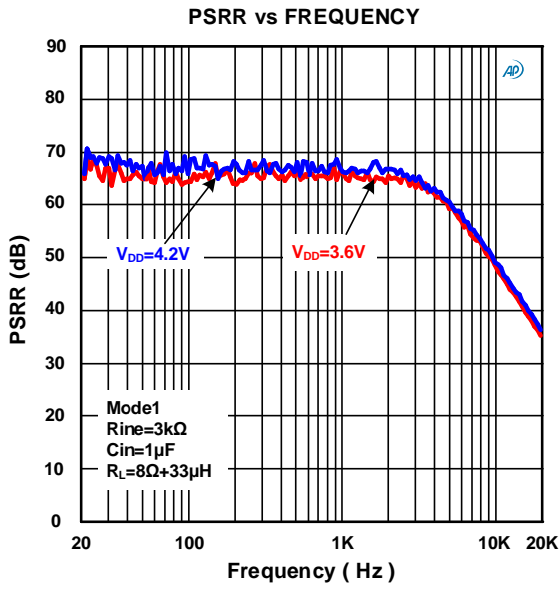

DETAILED FUNCTIONAL DESCRIPTION

AW87327 is specifically designed to enhance overall sound quality. It is an upgrading 7th-generation class K audio amplifier with high efficiency, low noise, ultra-low distortion and capability of outputting constant large volume.

With integrated AWINIC proprietary NCN output AGC audio algorithm, AW87327 can eliminate noise in playback and improve sound quality and effect. Using a novel K-Chargepump technology, its integrated charge pump efficiency can reach 93%, and power amplifier's overall efficiency can reach 80%. With high efficiency, AW87327 can greatly prolong smart phone usage time.

AW87327 noise floor is as low as to 53 μ V, with 97dB high signal-to-noise-ratio (SNR). The ultra-low distortion 0.008% brings high-quality musical enjoyment.

AW87327 has a setting of 4-step selectable speaker-guard output power level from 0.6W to 1.2W, suitable for different rated power speakers. Within lithium battery voltage range, it keeps output power constant, preventing voice from degrading.

AW87327 supports speaker and receiver two-in-one application. The Class AB Receiver Mode has an ultra-low output noise of 11 μ V and an ultra-high power supply noise suppression of -100dB@217Hz.

AW87327 has built-in over-current protection, over-temperature protection and short-circuit protection. AW87327 is available in a 1.575mm \times 1.575mm, 0.4mm pitch CSP-14 package.

Constant Output Power

In the smart phone audio applications, the AGC function which can promote music volume and audio quality is very attractive, but as the lithium battery voltage drops, the driver capability of ordinary audio power amplifiers will reduce gradually, leading to degrading audio effect. Therefore, it is hard to provide high-quality music within the battery voltage range.

With integrated AWINIC proprietary NCN output AGC audio algorithm and within lithium battery voltage range (3.3V to 4.35V), AW87327 can keep output power constant and never decreasing during lithium battery voltage dropping down. As a result, even if the battery voltage drops, AW87327 can still provide high-quality large-volume music enjoyment.

AW87327 has 7 operating modes. The first 4 modes have NCN output AGC function and their output AGC power levels are 1.2W, 1W, 0.8W, 0.6W, respectively.

2nd Generation NCN Technology

In audio application, there is undesirable distortion in a clipping output signal, because of a too large input signal along with a drop of supply voltage powered by lithium battery. To prevent a speaker load from permanent damage by a clipping output signal, adoption of traditional NCN technology can adjust gain of power amplifier automatically by detecting "Crack" distortion in a output signal, and keep the output signal smooth without clipping. NCN function can effectively prevent a power amplifier overloading, protect a speaker load, and bring high quality music enjoyment at the same time. A traditional NCN function is shown in Figure 9 below.

By adopting AWINIC unique 2nd generation NCN technology, AW87327's output signal is not limited by lithium battery voltage. When battery voltage drops, output signal keeps unchanged and free from distortion, realizing constant output power as shown in figure 10. Therefore, even if battery voltage drops, AW87327 can still provide high quality large volume music enjoyment.

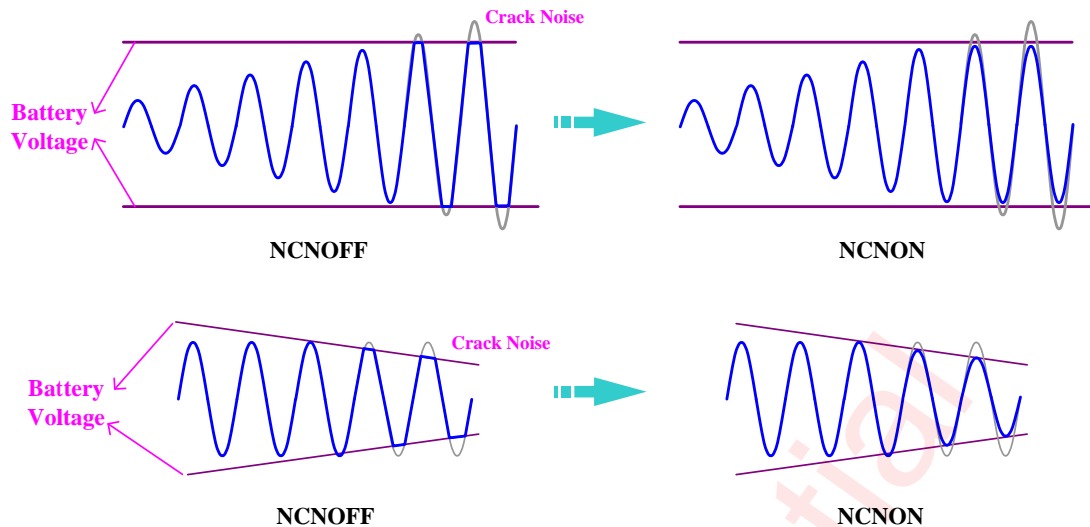
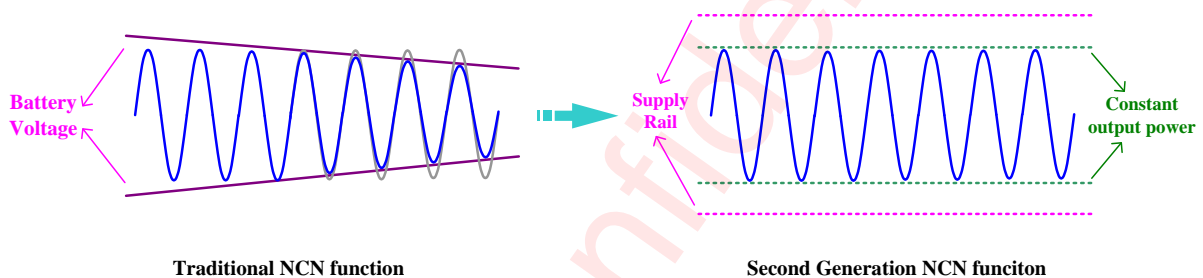

Figure 9 Traditional NCN Operating Principle

Figure 10 2nd Generation NCN Operating Principle

Attack Time

Attack time is the time which NCN output AGC takes for the gain to be attenuated by 13.5dB when audio signal exceeds the constant output power threshold level. Short attack time (fast attack) allows NCN function to react quickly and suppress harmful transients. However, it can lead to volume pumped and make process of gain reduction noticeable. While long attack time (slow attack) makes NCN function ignore fast transients and act upon longer passages instead, resulting in an increase of distortion. According to audio features in portable equipment, attack time in AW87327 is set to be 40ms, improving the music rhythm, eliminating crack distortion, and protecting the speaker at the same time.

Release time

Release time is the time which NCN output AGC takes for the gain to return to its setting value when audio signal is smaller than clipping level or constant output power threshold level. According to features of music noise in smart phone application and demands for better music quality and volume, release time of AW87327 is designed to be 1.2s, which can effectively eliminate the noise, and make sound smoother.

K-Chargepump

AW87327 adopts a new generation of charge pump technology: K-Chargepump structure. It has higher efficiency and larger driving capability. Its operating frequency is 1.06MHz. With built-in soft-start circuit, current-limit control loop and over-voltage-protection (OVP) loop, charge pump of this configuration can provide more stable and reliable power supply.

High Efficiency

The output voltage PVDD is 1.5 times of supply voltage VDD in K-Chargepump, of which the ideal efficiency can reach 100%. Actually, the K-Chargepump efficiency can be calculated as the ratio of output power to input power, that is

$$\eta = \frac{P_{OUT}}{P_{IN}} \times 100\%$$

For example, in an ideal M-times charge pump, the input current I_{IN} is M times of the output current I_{OUT} , the efficiency formula can be written as:

$$\eta = \frac{P_{OUT}}{P_{IN}} \times 100\% = \frac{V_{OUT} \cdot I_{OUT}}{V_{IN} \cdot M \cdot I_{OUT}} \times 100\% = \frac{V_{OUT}}{M \cdot V_{IN}} \times 100\%$$

Also, M is a parameter depending on the operating mode of a charge pump; V_{OUT} is the output voltage of a charge pump; V_{IN} is the input voltage (generally is also the power supply voltage) of a charge pump; I_{OUT} is also the load current. For K-Chargepump structure, the output voltage is 1.5 times of the input voltage. Due to the switch loss and quiescent current loss inside the charge pump, the actual efficiency can still be up to 93%. As a result, the power booster technology of K-Chargepump can greatly improve the power efficiency.

K-Chargepump Structure

As shown in Figure 11 is a K-Chargepump fundamental functional diagram: K-Chargepump integrated in AW87327 has seven switches, of which the output voltage PVDD is boosted to 1.5 times as input voltage VDD through seven switches operating timing.

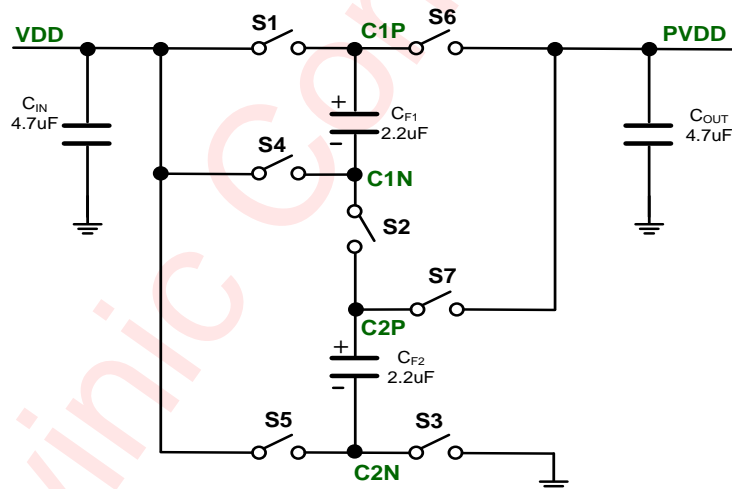

Figure 11 K-Chargepump Functional Diagram

The operation of the charge pump has two phases. In Φ_1 , as shown in Figure 12, when switches S1, S2 and S3 are closed, VDD charges to the flying capacitor C_{F1} and C_{F2} .

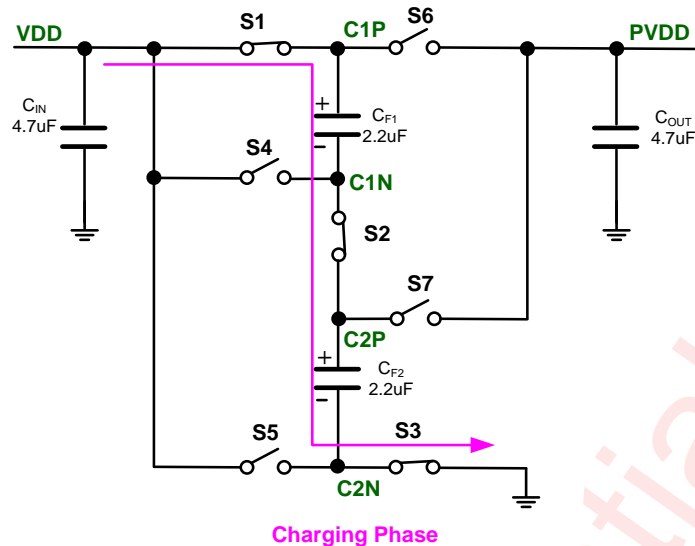

Figure 12 Φ_1 : Charge Flying Capacitors C_{F1} and C_{F2}

In Φ_2 , as shown in Figure 13, switches S1, S2 and S3 are opened, and switches S4, S5, S6 and S7 are closed. Because the voltage across the capacitor can't change instantaneously, so either the voltage on flying capacitors C_{F1} or C_{F2} , is added to the VDD, realizing a PVDD boosted to a higher voltage.

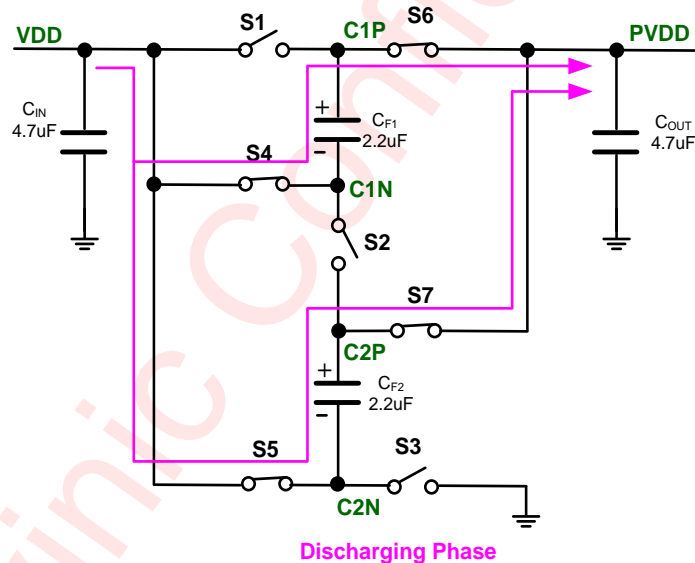

Figure 13 Φ_2 : Flying Capacitor Charges Transfer to the Output Capacitor C_{OUT}

Soft Start

K-chargepump has integrated soft start function in order to limit inrush current from power supply during start-up. The current from power supply can be limited to 300mA, and the start-up time is about 1.2ms.

Peak Current Control

K-chargepump has integrated a peak current control circuit. In normal operation, when a heavy load or a situation that makes the charge pump extracts very large current from power supply, the peak current control circuit can limit the maximum output load current, which is typically 2A.

Over-Voltage Protection (OVP)

K-Chargepump keeps the output voltage PVDD a Singleple of the input voltage VDD. It provides a high voltage power rail for internal power amplifier circuits, allowing the amplifiers provide greater output dynamic range in

the lithium battery voltage range, realizing much larger volume, higher audio quality. K-Chargepump has integrated a over-voltage protection circuit. When the input voltage VDD is greater than 4V, the output voltage PVDD is no longer a multiple of VDD, but a controlled voltage by over-voltage protection (OVP) circuit and kept in 6.05V. The hysteresis voltage of OVP is about 50mV.

Speaker & Receiver Two-in-One Application

Both Mode5 and Mode6 of AW87327 are Class AB Receiver Modes. Their gain are selectable, 1V/V and 3V/V, respectively, for the application flexibility. By multiplexing the speaker's signal path, AW87327 Receiver Modes have ultra-low distortion and strong driving capability. Therefore, it is suitable for high-resolution voice calls. Another advantage is that there is no need to use additional external components, reducing system cost and saving PCB layout space.

In typical application as Figure 4 shown, with input capacitor $C_{in}=47nF$ and input resistor $R_{in}=3k\Omega$, the gain at Speaker Mode is about 16.3V/V, and the corner frequency of the input high-pass RC filter is about 173Hz. At Receiver Mode (Mode5), the gain is changed to 1V/V, with ultra-low output noise of 11 μ V, and the corner frequency of the input high-pass RC filter is about 71Hz. AW87327 can realize a speaker & receiver two-in-one application without changing any hardware.

One-Wire Pulse Control: Principle

One-wire pulse control technology only needs a single GPIO port to turn on the chip and select a variety of functions. It is very popular in an environment lack of GPIO ports, such as portable systems.

Considering the problems of signal integrity or RF interference, there is narrow glitch in signal line when the PCB routine is too long. AWINIC one-wire pulse control technology integrated a deglitch circuit along with the internal control pin. The deglitch-module can completely eliminate the harmful glitch interference, as shown in Figure 14.

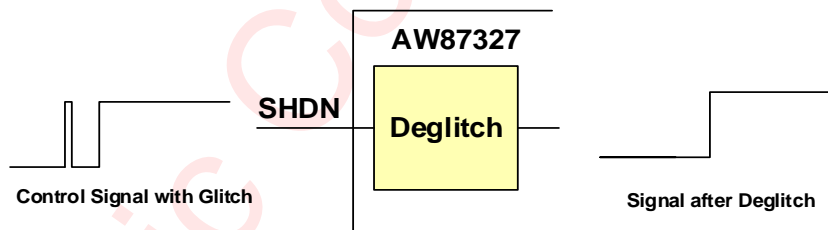

Figure 14 AWINIC Deglitch Working Principle

The traditional one-wire pulse control technology keeps working after the slave chip is powered up. Therefore, when the master chip (such as Baseband in a smart phone) sends other control signal through the same control port, the slave chip will probably enter into a wrong state. AW87327 uses one-wire pulse technology with a latch circuit, by which the right working state will be stored after the master chip sending order and AW87327 will no longer receive successive signals (except shutting down the chip firstly), as shown in Figure 15.

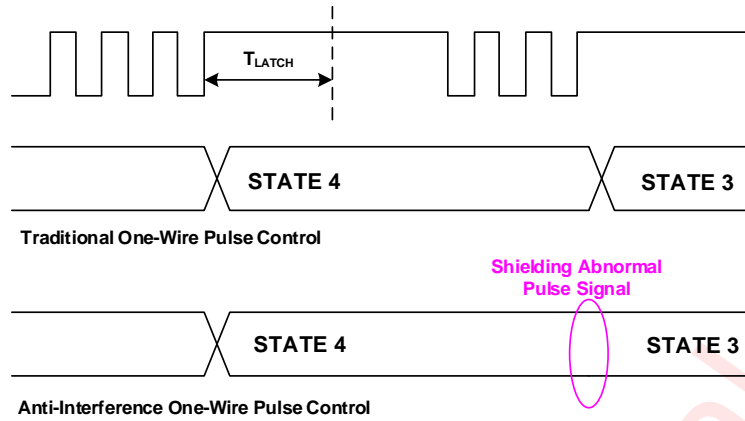

Figure 15 Anti-Interference One-Wire Pulse Control Functional Diagram

One-Wire Pulse Control: Working Mode

Each mode of AW87327 can be set by the on-wire pulse control circuit, which can detect the number of pulses sent by master chip through SHDN pin. When SHDN pulls to high level from shutdown state (low level), i.e. only a rising edge, AW87327 will enter into Mode1, and the constant output power level of NCN output AGC is 1.2W (with 8Ω speaker load). When SHDN shows a high-to-low-to-high logic signal, i.e. a rising edge after a pulse, or two rising edges, AW87327 will enter into Mode2, and the level is 1.0W. Similarly, N rising edges means Mode“N”, as shown in Figure 16. After all, AW87327 has seven operating modes, more than seven rising edges is forbidden.

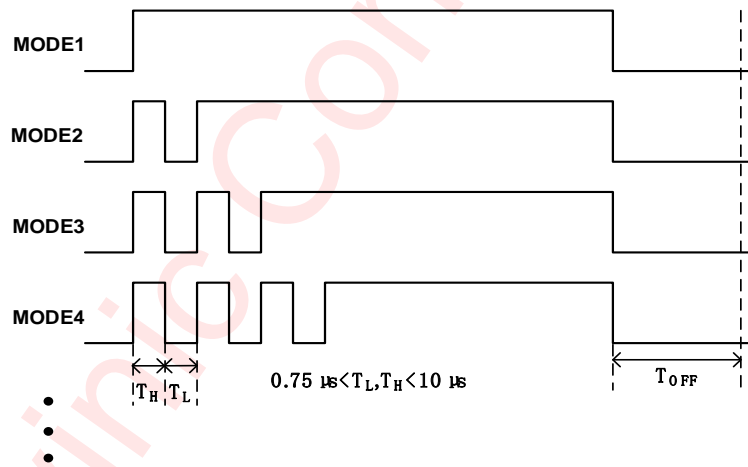

Figure 16 Working Mode Setting through One-Wire Pulse Control

To change the working mode of AW87327, one needs to keep SHDN low longer than T_{OFF} firstly (1ms is recommended), to shut down the chip. Then, send pulses to bring the chip into a right mode, as shown in Figure 17.

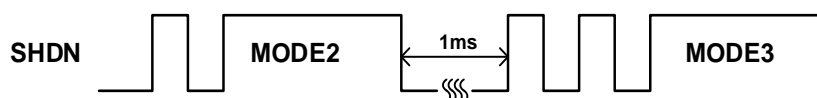

Figure 17 Mode Switch through One-Wire Pulse Control

RNS (RF Noise Suppression)

GSM transmission adopts TDMA (Time Division Multiple Access) Technology which results in frame burst at frequency of 217Hz, also called TDD (Time Division Duplexing), leading to a strong RF interference (RF Noise) and the 217Hz energy along with its harmonics (TDD Noise) can be easily interacted with audio power amplifiers.

In applications, optimization of both layout and selection of peripheral components may decrease the AW87327's susceptibility to RF noise and prevent TDD Noise from being demodulated into audible noise. Minimization of length of routings prevents them from functioning as antennas and coupling RF noise into an AW87327. Further RF immunity can also be realized by using capacitors of which feature of frequency response is like a notch filter. Depending on manufacturers, self-resonance frequency of 10pF to 20pF capacitors typically located at RF band. Such capacitors placed in front of input pins of AW87327 can effectively suppress RF noise. Also, such capacitors must have a low-impedance, low-inductance path to the ground plane.

Even if part of RF energy is injected into AW87327 by traces connected to the chip, regardless of efforts of TDD Noise Reduction. AW87327 features a unique RNS technology, which effectively reduces RF energy and attenuates RF TDD-noise to an acceptable audible level for customers.

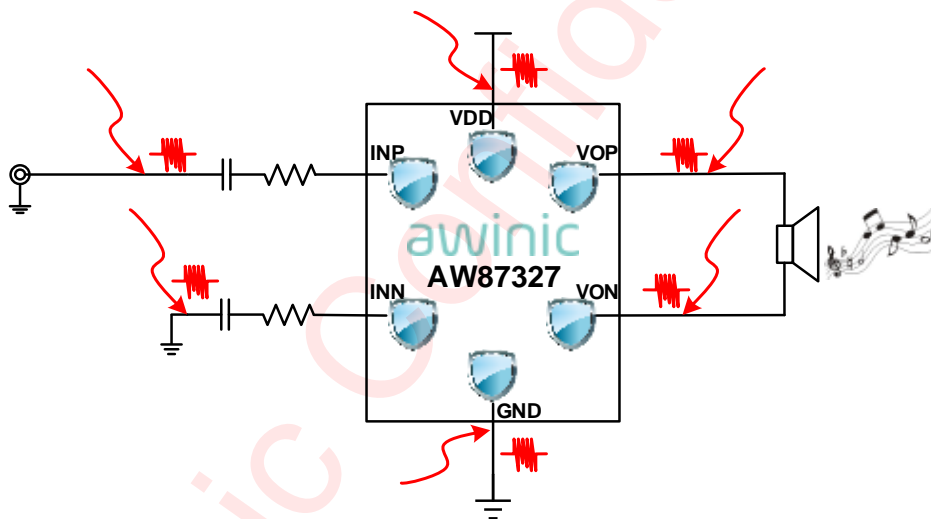

Figure 18 AW87327 Rejection of RF Noise

Filter-Free Pulse Width Modulation (Filter-Free PWM)

AW87327 features a filter-free PWM architecture which removes a LC filter behind the output stage of a traditional Class D power amplifier, resulting in improvement of overall efficiency, decrease of PCB area and reduction of system cost.

Enhanced Emission Elimination (EEE)

AW87327 features a unique Enhanced Emission Elimination (EEE) technology, which adjusts the speed of waveform transition of PWM output signal, and effectively reduces EMI over FM/AM bandwidth.

Pop-Click Suppression

AW87327 integrates a unique timing-control circuit, which fundamentally suppresses pop-click noise, and eliminates audible crack at shut-down, wake-up, and power-up/down.

Protection

When a short-circuit occurs among output pins (VOP, VON) and power pins (VDD, GND, PVDD) of AW87327, an over-current protection (OCP) circuit will be triggered and shut down the chip immediately, preventing the device from being damaged. When abnormal condition is removed, AW87327 can restart automatically without wake-up.

When junction temperature in AW87327 is too high, an over-temperature protection (OTP) circuit will be triggered and shut down the chip immediately. The circuit will turn the device on once the temperature decrease into a safe scope.

awinic Confidential

APPLICATION INFORMATION

Gain Setting -- Selection of External Input Resistor (R_{ine})

AW87327 is a differential-input audio power amplifier. It integrates two internal input resistors (R_{ini}), which are both 16.6k Ω . Take external input resistors $R_{ine}=3k\Omega$ for instance, overall gain (A_V) can be set as below:

AW87327 Mode	Calculation of Overall Gain (V/V)
Class K Speaker Mode (Mode1~4, and Mode7)	$A_V = \frac{319.5k\Omega}{R_{ine} + R_{ini}} = \frac{319.5k\Omega}{3k\Omega + 16.6k\Omega} = 16.3V/V$
Class AB Receiver Mode with 1V/V gain (Mode5)	$A_V = \frac{48k\Omega}{R_{ine} + R_{ini}} = \frac{48k\Omega}{3k\Omega + 45k\Omega} = 1V/V$
Class AB Receiver Mode with 3V/V gain (Mode6)	$A_V = \frac{144k\Omega}{R_{ine} + R_{ini}} = \frac{144k\Omega}{3k\Omega + 45k\Omega} = 3V/V$

Input High-Pass Cutoff Frequency Setting -- Selection of Input Capacitor (C_{in})

Input capacitors in front of external input resistors can block DC component of input audio signals. An input capacitor (C_{in}) along with input resistors ($R_{ine}+R_{ini}$) forms an input high-pass filter with a corner frequency (f_H) calculated as below:

$$f_H(-3dB) = \frac{1}{2\pi(R_{ine} + R_{ini})C_{in}}$$

A higher f_H results in a better suppression of 217Hz GSM input noise. A better matching of input capacitors improves capability of blocking of common-mode interference of input stage in AW87327 and also helps to reduce pop-click noise.

Take typical application in Figure 1 for instance:

$$f_H(-3dB) = \frac{1}{2\pi(R_{ine} + R_{ini})C_{in}} = \frac{1}{2\pi \cdot 19.6k \cdot 47nF} = 173Hz$$

Besides, take Class AB Receiver Mode with 1V/V gain (Mode8) for instance:

$$f_H(-3dB) = \frac{1}{2\pi(R_{ine} + R_{ini})C_{in}} = \frac{1}{2\pi \cdot 48k \cdot 47nF} = 71Hz$$

Input Low-Pass Cutoff Frequency Setting – Selection of Differential Input Capacitor (C_d)

A differential input capacitor behind external input resistors can block high-frequency component of input audio signals, such as screechy part in a song. A differential input capacitor (C_d) along with input resistors ($R_{ine}+R_{ini}$) forms an input low-pass filter with a corner frequency (f_L) calculated as below:

$$f_L(-3dB) = \frac{1}{4\pi(R_{ine} // R_{mi})C_d}$$

Take typical application in Figure 1 with $C_d=220pF$ and $R_{ine}=3k\Omega$ for instance:

$$f_L(-3dB) = \frac{1}{4\pi \cdot (3k\Omega // 16.6k\Omega) \cdot 220pF} = 142.5kHz$$

Selection of Power Supply Decoupling Capacitor (Cs)

AW87327 is a high-performance audio power amplifier. It is essential to place a ceramic capacitor (C_s) with low equivalent-series-resistance (ESR) (typical $0.1\mu F$) for power supply decoupling. Optimized selection and placement of decoupling capacitors protect AW87327 from interference injection from power supply, such as high-frequency transients, spikes, or digital noise. Specifically, a layout of decoupling capacitor closer to AW87327 is preferred, since fewer parasitic resistance or inductance between power pin and the capacitor, less decoupling efficiency loss. In addition to a $0.1\mu F$ ceramic capacitor, another $10\mu F$ capacitor as a charge reservoir is required, providing transient power energy for AW87327 and preventing remarkable drop of the power supply voltage.

Selection of Charge Pump Flying Capacitor (C_F)

Value of charge pump flying capacitors (C_F) affects load regulation and output impedance of the charge pump. Small capacitance may degrade driving capability of AW87327. A $2.2\mu F/6.3V$ ceramic capacitor is usually recommended.

Selection of Charge Pump Output Capacitor (C_{OUT})

Capacitance and ESR of charge pump output capacitors (C_{OUT}) directly affect ripple magnitude of charge pump output voltage (PVDD). Increasing C_{OUT} Capacitance reduces variations of PVDD and decreasing C_{OUT} ESR also reduces both ripple and output resistance. A $4.7\mu F/10V$ ceramic capacitor is usually recommended.

Usage of Ferrite Bead and Filter Capacitor

Without ferrite beads and filter capacitors, AW87327 can still pass the specifications of FCC and CE. If there is any EMI sensitive device near AW87327 and/or there are long traces routing from the amplifier to a speaker, use ferrite beads and filter capacitors and place beads and capacitors as close as possible to output pins (VOP&VON), as Figure 19 below.

In Class K Speaker Mode, outputs of AW87327 are square-wave PWM signals, which charge and discharge filter capacitors in each period, and result in additional static power consumption. Bigger filter capacitance, larger current consumption. Therefore, $0.1nF$ ceramic capacitor is usually recommended for low power application.

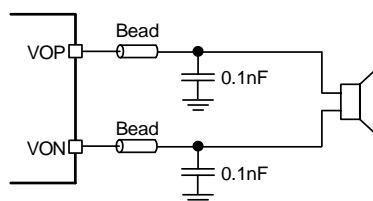

Figure 19 Ferrite Beads and Filter Capacitors

PCB AND DEVICE LAYOUT CONSIDERATION

In order to exploit best performance of AW87327, PCB layout must be carefully considered. Design consideration should be followed as below:

1. Isolated, short and wide power lines for both VDD pin and GND pin are required for better driving-capability of AW87327. The copper width is recommended to be larger than 0.75mm (30mil). Power supply decoupling capacitors should be placed as close as possible to power supply pins.
2. Flying capacitors C_{F1} , C_{F2} should be placed as close as possible to C1N, C1P pins and C2N, C2P pins. Likewise, capacitor C_{OUT} should be close to PVDD pin. The trace from C_{OUT} to both PVDD pin and GND pin should be short and wide.
3. Input capacitors and resistors should be close to INN and INP pins. Differential and ground-shielding input routing is required to suppress noise coupling.
4. Ferrite beads and filter capacitors should be close to VON and VOP pins. The trace from output pins to speaker should be short and wide. The copper width is recommended to be larger than 0.5mm (20mil).

PACKAGE INFORMATION

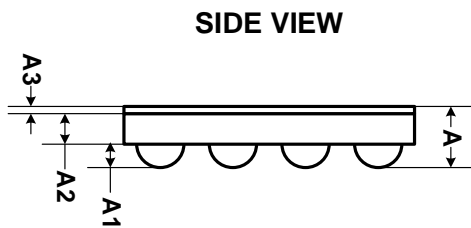
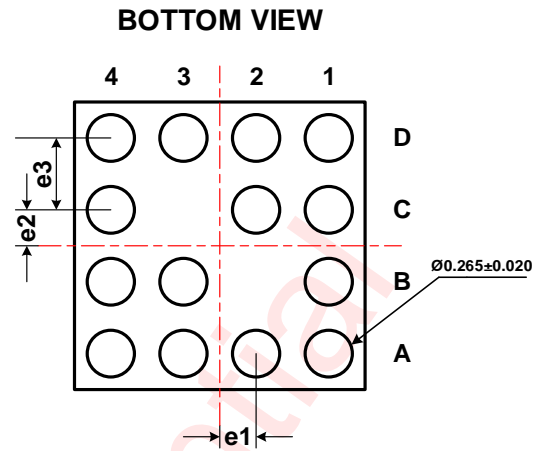
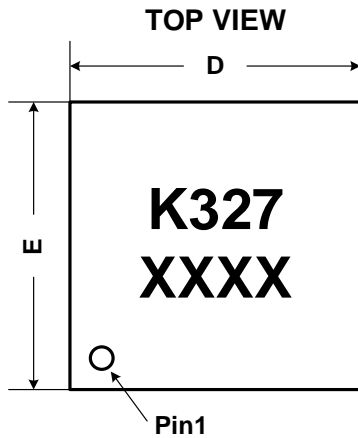

Symbol	NOM	Tolerance
A	0.575	± 0.055
A1	0.195	± 0.020
A2	0.340	± 0.025
A3	0.040	± 0.010
D	1.575	± 0.025
E	1.575	± 0.025
e1	0.200	NA
e2	0.200	NA
e3	0.400	NA

Unit: mm

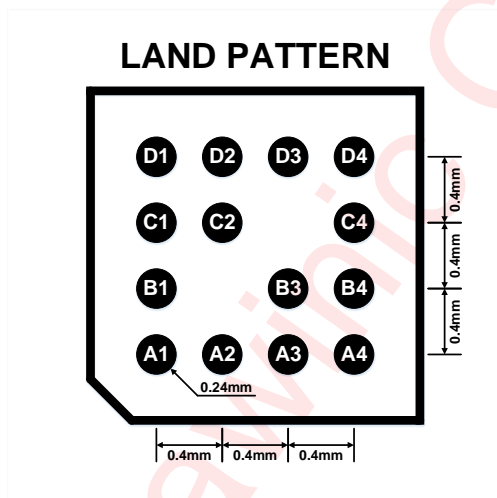

TAPE INFORMATION

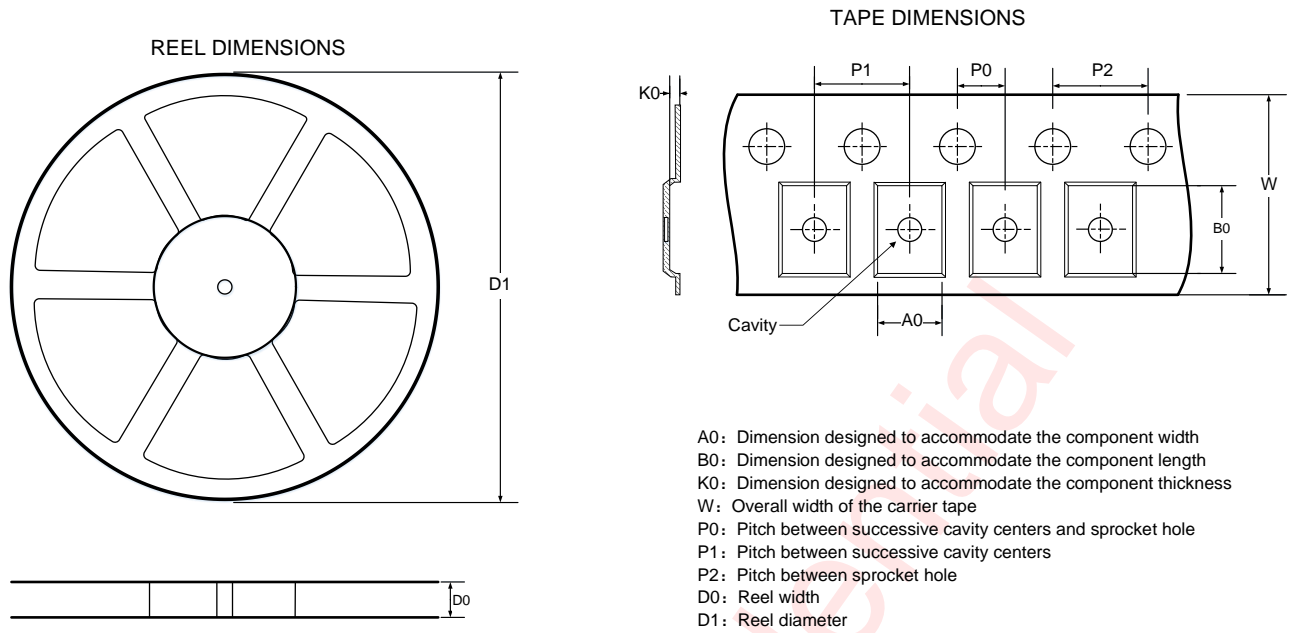

QUADRANT ASSIGNMENTS FOR PIN 1 ORIENTATION IN TAPE

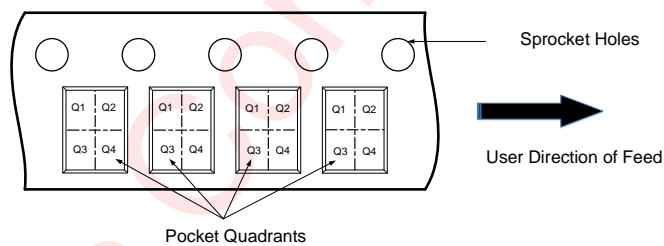

All dimensions are nominal

D1 (mm)	D0 (mm)	A0 (mm)	B0 (mm)	K0 (mm)	P0 (mm)	P1 (mm)	P2 (mm)	W (mm)	Pin1 Quadrant
179.00	9.00	1.73	1.73	0.72	2.00	4.00	4.00	8.00	Q1

REFLOW SOLDERING CURVE

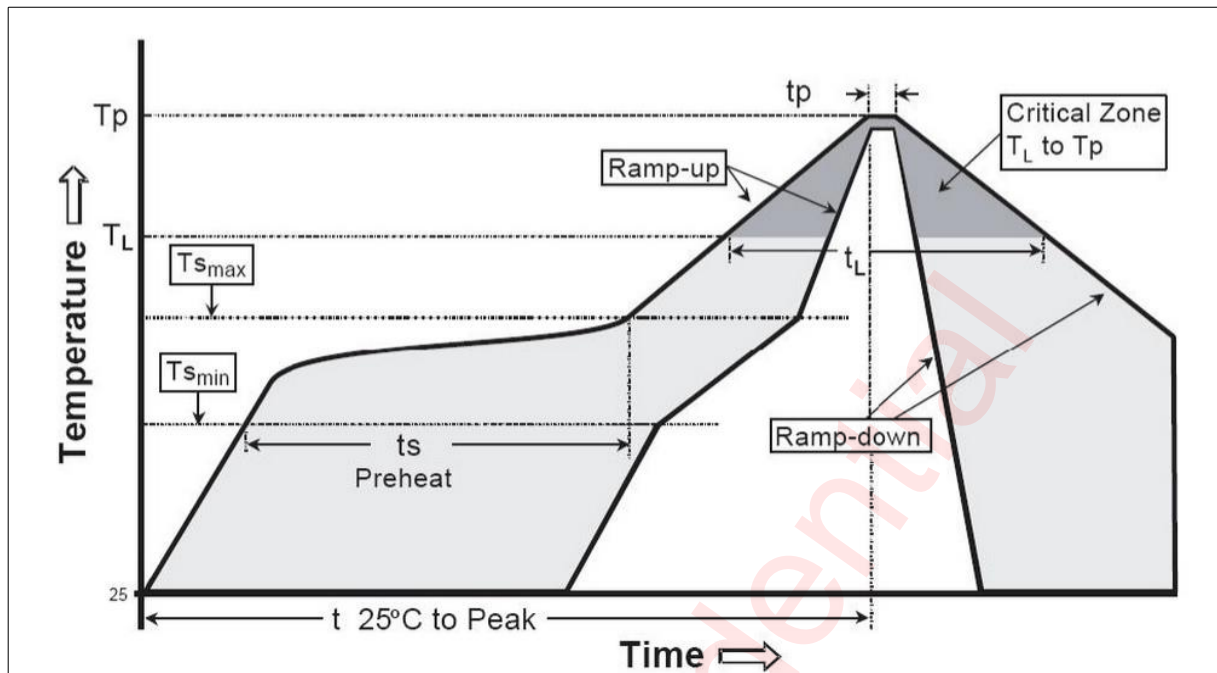

Reflow Note	Spec
Average Ramp-up Rate (217°C to Peak)	Max. 3°C/sec
Time of Preheat temp. (from 150°C to 200°C)	60sec-120sec
Time to be Maintained above 217°C	60sec-150sec
Peak Temperature	250°C~260°C
Time within 5°C of Actual Peak Temp	20sec-40sec
Ramp-down Rate	Max. 6°C/sec
Time from 25°C to Peak Temp	Max. 8min

VERSION INFORMATION

Version	Date	Description
V1.0	2017-05-07	AW87327CSR datasheet V1.0
V1.1	2018-09-13	Change Cin value from 33nF to 47nF Add Output Power of Receiver Mode
V1.2	2020-04-29	Change the curve of Multi-level AGC for Mode1~Mode4 Change PSRR to positive value Change the THD+N test condition from Mode1 to Mode 10

awinic Confidential

DISCLAIMER

Information in this document is believed to be accurate and reliable. However, Shanghai AWINIC Technology Co., Ltd (AWINIC Technology) does not give any representations or warranties, expressed or implied, as to the accuracy or completeness of such information and shall have no liability for the consequences of use of such information.

AWINIC Technology reserves the right to make changes to information published in this document, including without limitation specifications and product descriptions, at any time and without notice. Customers shall obtain the latest relevant information before placing orders and shall verify that such information is current and complete. This document supersedes and replaces all information supplied prior to the publication hereof.

AWINIC Technology products are not designed, authorized or warranted to be suitable for use in medical, military, aircraft, space or life support equipment, nor in applications where failure or malfunction of an AWINIC Technology product can reasonably be expected to result in personal injury, death or severe property or environmental damage. AWINIC Technology accepts no liability for inclusion and/or use of AWINIC Technology products in such equipment or applications and therefore such inclusion and/or use is at the customer's own risk.

Applications that are described herein for any of these products are for illustrative purposes only. AWINIC Technology makes no representation or warranty that such applications will be suitable for the specified use without further testing or modification.

All products are sold subject to the general terms and conditions of commercial sale supplied at the time of order acknowledgement.

Nothing in this document may be interpreted or construed as an offer to sell products that is open for acceptance or the grant, conveyance or implication of any license under any copyrights, patents or other industrial or intellectual property rights.

Reproduction of AWINIC information in AWINIC data books or data sheets is permissible only if reproduction is without alteration and is accompanied by all associated warranties, conditions, limitations, and notices. AWINIC is not responsible or liable for such altered documentation. Information of third parties may be subject to additional restrictions.

Resale of AWINIC components or services with statements different from or beyond the parameters stated by AWINIC for that component or service voids all express and any implied warranties for the associated AWINIC component or service and is an unfair and deceptive business practice. AWINIC is not responsible or liable for any such statements.