

BCZ120N32W1

N-Channel Silicon Carbide Power MOSFET

1200 V, 69 A, 32mΩ



bestirpower

Features

- High switching speed with a low gate charge
- Low On-Resistance with High Blocking Voltage
- Low Capacitances with High-Speed switching
- Low reverse recovery (Q_{rr})
- Halogen Free, and RoHS Compliant

BV _{DSS} , T _C =25°C	I _D , T _C =25°C	R _{DS(on)} ,typ	Q _g ,typ
1200 V	69 A	32 mΩ	121nC

Benefits

- Reduce switching losses
- Increased system Switching
- Frequency Increased power density
- Reduction of heat sink requirements

Applications

- Switch mode power supplies
- Renewable energy
- Motor drives
- High voltage DC/DC converters

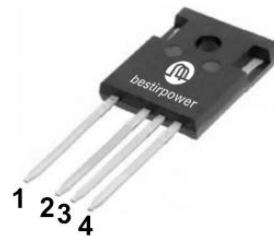

TO-247-4L

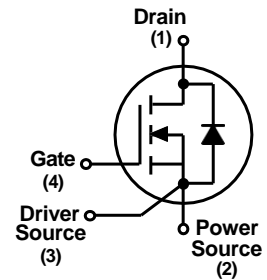

Absolute Maximum Ratings (T_J = 25°C unless otherwise noted)

Symbol	Parameter	Value	Unit	
V _{DSS}	Drain to Source Voltage	1200	V	
V _{GS}	Gate to Source Voltage (DC)	-10 / +25	V	
V _{GSop}	Recommended Operation Value	-4 / +20	V	
I _D	Drain Current	Continuous (V _{GS} =18V, T _C = 25°C)	69	A
		Continuous (V _{GS} =18V, T _C = 100°C)	49	
I _{DM}	Drain Current	Pulse with t _p limited by T _{Jmax} at 1 ms	140	A
		Pulse with t _p limited by T _{Jmax} at 100 μs	331	
P _D	Power Dissipation	348	W	
T _J , T _{STG}	Operating and Storage Temperature Range	-55 to 175	°C	

Thermal Characteristics

Symbol	Parameter	Value	Unit
R _{θJC}	Thermal Resistance, Junction to Case, Max.	0.43	°C/W
R _{θJA}	Thermal Resistance, Junction to Ambient, Max.	40	
T _{sold}	Soldering temperature, wave soldering only allowed at leads	260	°C

Electrical Characteristics ($T_J = 25^\circ\text{C}$ unless otherwise noted)

Symbol	Parameter	Test Conditions	Min	Typ	Max	Unit
--------	-----------	-----------------	-----	-----	-----	------

Off Characteristics

BV_{DSS}	Drain to Source Breakdown Voltage	$V_{GS} = 0\text{ V}, I_D = 100\ \mu\text{A}$	1200	-	-	V
I_{DSS}	Zero Gate Voltage Drain Current	$V_{DS} = 1200\text{ V}, V_{GS} = 0\text{ V}$	-	1	50	μA
I_{GSS}	Gate-Source Leakage Current	$V_{GS} = 18\text{ V}, V_{DS} = 0\text{ V}$	-	-	250	nA

On Characteristics

$V_{GS(th)}$	Gate Threshold Voltage	$V_{GS} = V_{DS}, I_{DS} = 11.5\text{ mA}$	-	2.9	-	V
		$V_{GS} = V_{DS}, I_{DS} = 11.5\text{ mA}, T_J = 175^\circ\text{C}$	-	2.0	-	
$R_{DS(on)}$	Static Drain to Source On Resistance	$V_{GS} = 18\text{ V}, I_D = 40\text{ A}$	-	32	48	mΩ
		$V_{GS} = 20\text{ V}, I_D = 40\text{ A}$	-	30	-	
		$V_{GS} = 18\text{ V}, I_D = 40\text{ A}, T_J = 175^\circ\text{C}$	-	58	-	
		$V_{GS} = 20\text{ V}, I_D = 40\text{ A}, T_J = 175^\circ\text{C}$	-	52	-	
g_{fs}	Transconductance	$V_{GS} = 18\text{ V}, I_D = 40\text{ A}$	-	26	-	S
		$V_{GS} = 20\text{ V}, I_D = 40\text{ A}, T_J = 175^\circ\text{C}$	-	22	-	

Dynamic Characteristics

C_{iss}	Input Capacitance	$V_{DS} = 1000\text{ V}, V_{GS} = 0\text{ V},$ $f = 1\text{ MHz}, V_{AC} = 25\text{ mV}$	-	2812	-	pF
C_{oss}	Output Capacitance		-	111	-	
C_{riss}	Reverse Capacitance		-	7	-	
$Q_{g(tot)}$	Total Gate Charge	$V_{DD} = 800\text{ V}, V_{GS} = -4/18\text{ V}, I_D = 40\text{ A}$	-	121	-	nC
Q_{gs}	Gate to Source Charge		-	20.9	-	
Q_{gd}	Gate to Drain "Miller" Charge		-	23.2	-	
R_G	Internal Gate Resistance	$f = 1\text{ MHz}, V_{AC} = 25\text{ mV}$ open drain	-	1	-	Ω

Switching Characteristics

$t_{d(on)}$	Turn-On Delay Time	$V_{DD} = 800\text{ V}, V_{GS} = -4/18\text{ V},$ $I_D = 40\text{ A}, R_{G(ext)} = 5\ \Omega,$ $L = 276\ \mu\text{H}$	-	23	-	ns
t_r	Turn-On Rise Time		-	9	-	
$t_{d(off)}$	Turn-Off Delay Time		-	27	-	
t_f	Turn-Off Fall Time		-	11	-	
E_{on}	Turn-on Switching Energy		-	352	-	μJ
E_{off}	Turn-off Switching Energy		-	170	-	

Source-Drain Diode Characteristics

I_S	Diode Forward Current	$V_{GS} = -4\text{ V}$	-	72	-	A
V_{SD}	Diode Forward Voltage	$V_{GS} = -4\text{ V}, I_{SD} = 20\text{ A}$	-	3.9	-	V
		$V_{GS} = -4\text{ V}, I_{SD} = 20\text{ A}, T_J = 175^\circ\text{C}$	-	3.3	-	
t_{rr}	Reverse Recovery Time	$V_R = 800\text{ V}, V_{GS} = -4\text{ V}, I_{SD} = 40\text{ A},$ $\text{dif/dt} = 3800\text{ A}/\mu\text{s}$	-	31	-	ns
Q_{rr}	Reverse Recovery Charge		-	281	-	nC
I_{rrm}	Peak Reverse Recovery Current		-	18	-	A

Typical Performance Characteristics

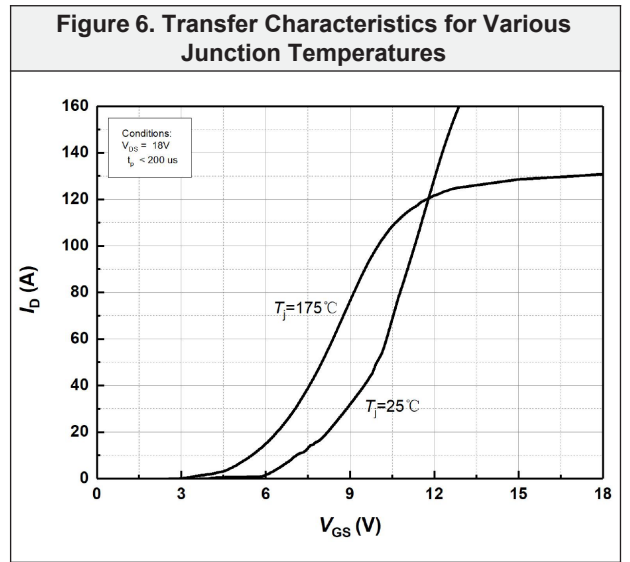
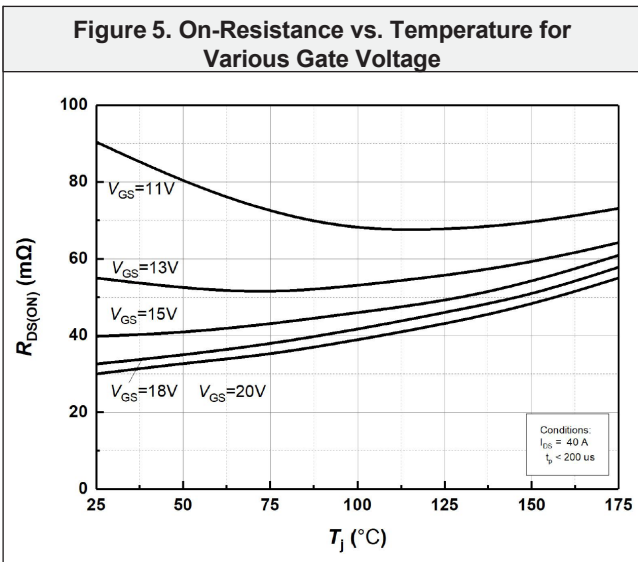
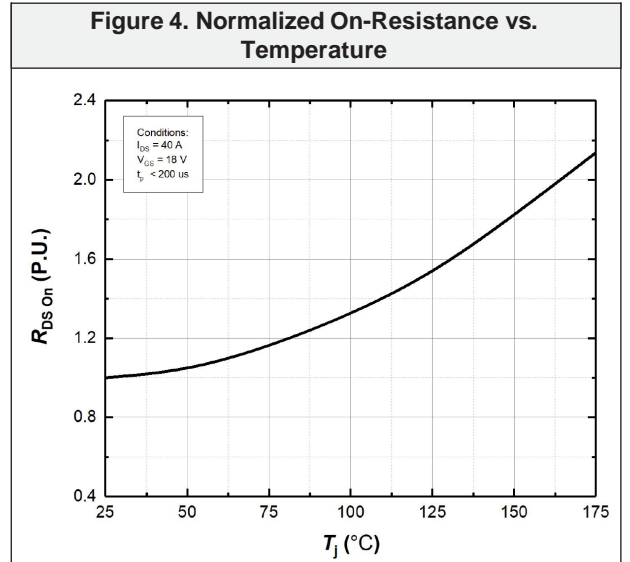
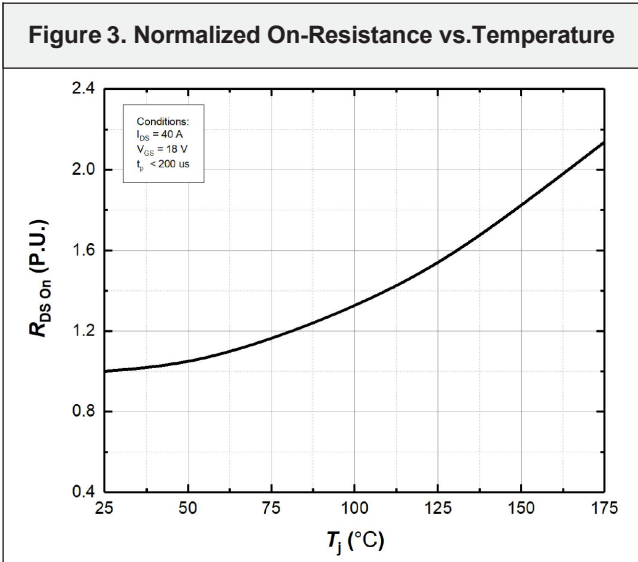
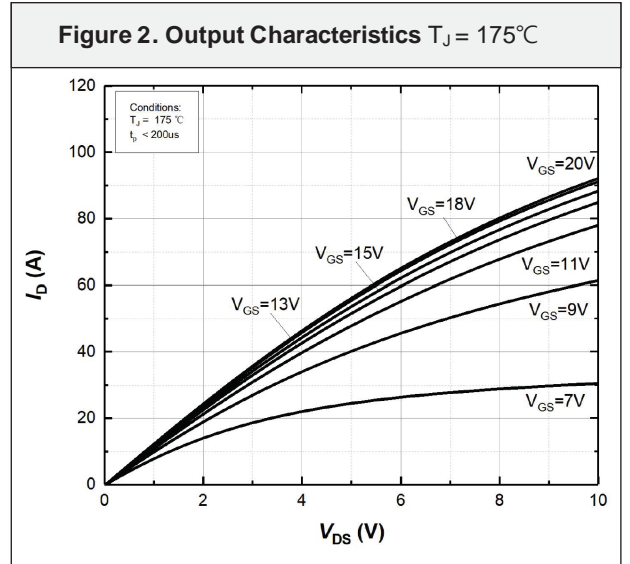
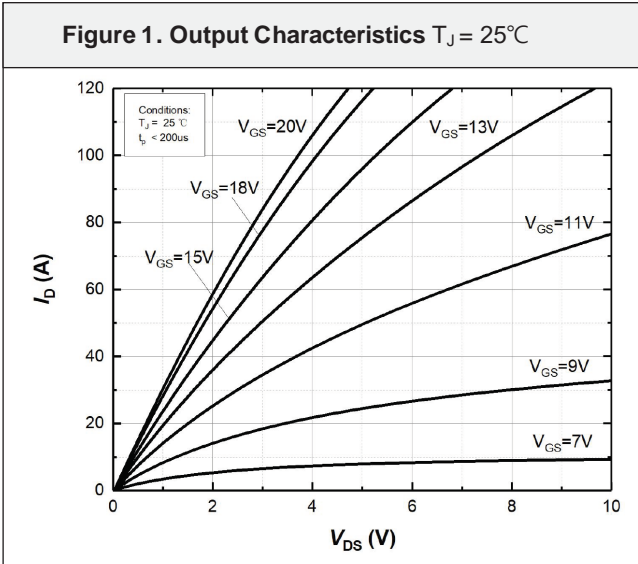

Typical Performance Characteristics

Figure 7. Body Diode Characteristics at $T_J = 25^\circ\text{C}$

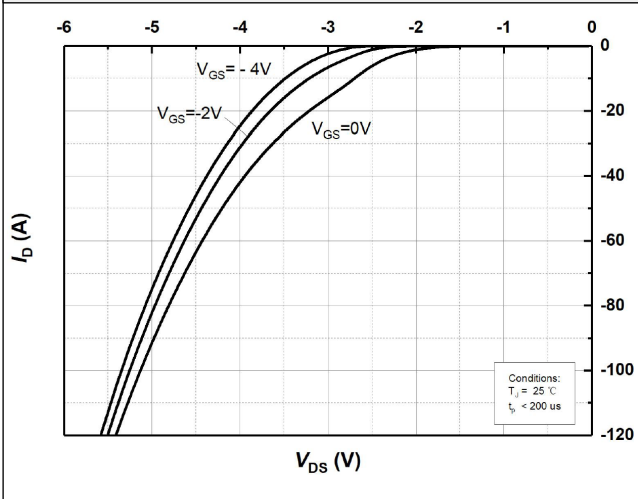

Figure 8. Body Diode Characteristics at $T_J = 175^\circ\text{C}$

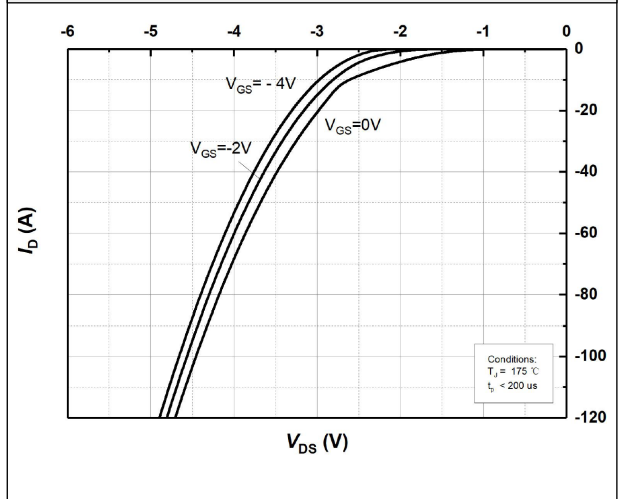

Figure 9. Threshold Voltage vs. Temperature

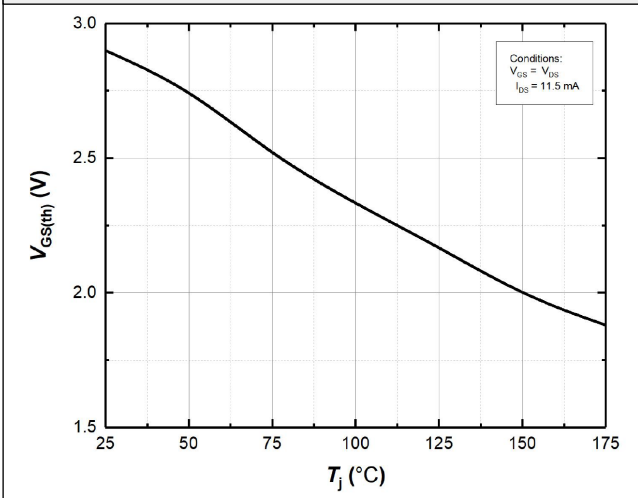

Figure 10. Gate Charge Characteristics

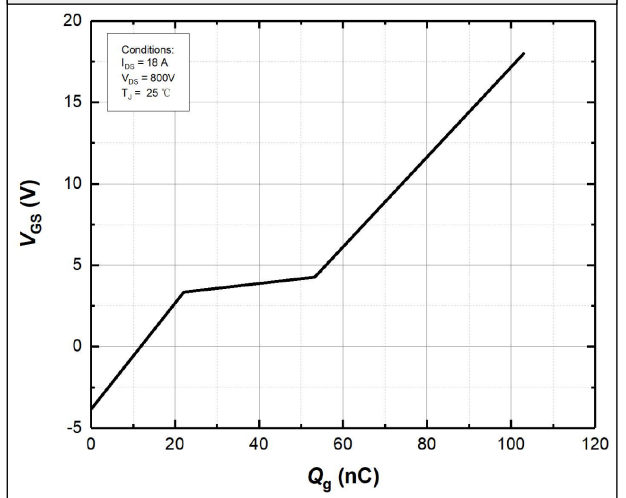

Figure 11. 3rd Quadrant Characteristic at $T_J = 25^\circ\text{C}$

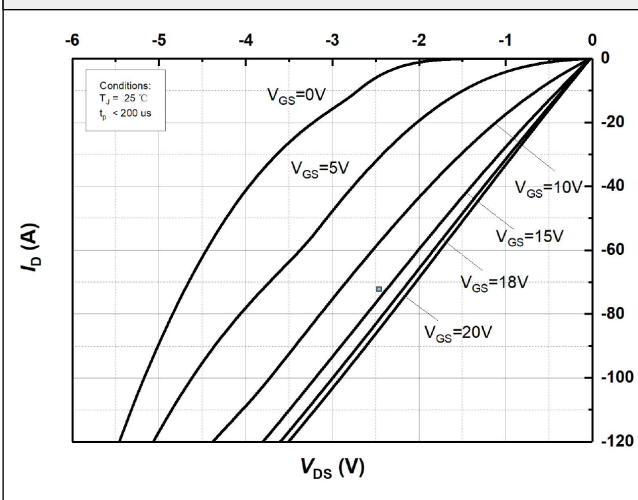
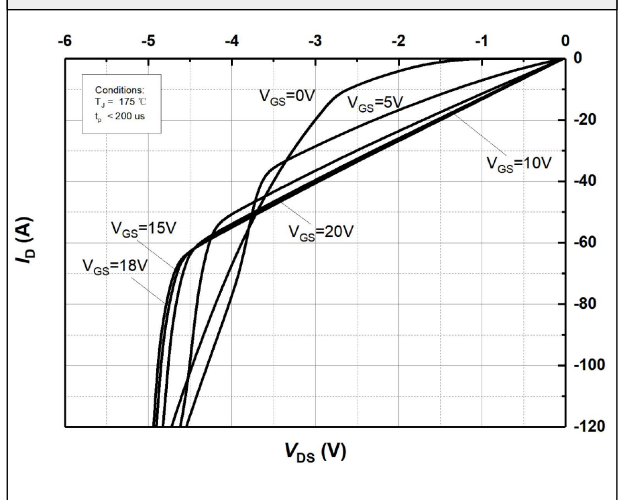

Figure 12. 3rd Quadrant Characteristic at $T_J = 175^\circ\text{C}$



Typical Performance Characteristics

Figure 13. Capacitances vs. Drain-Source Voltage

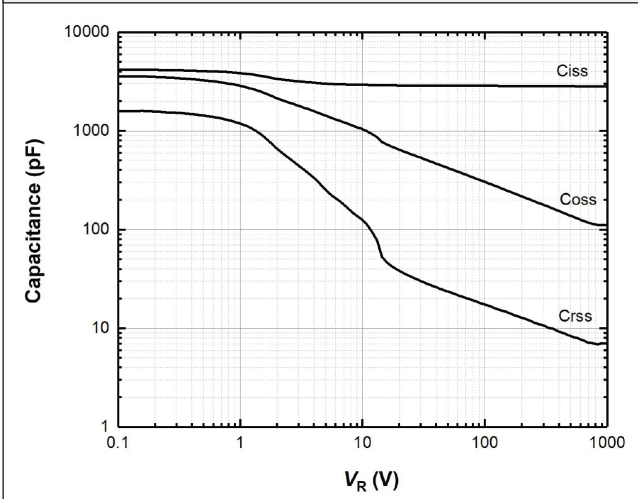

Figure 14. Continuous Drain Current Derating vs. Case Temperature

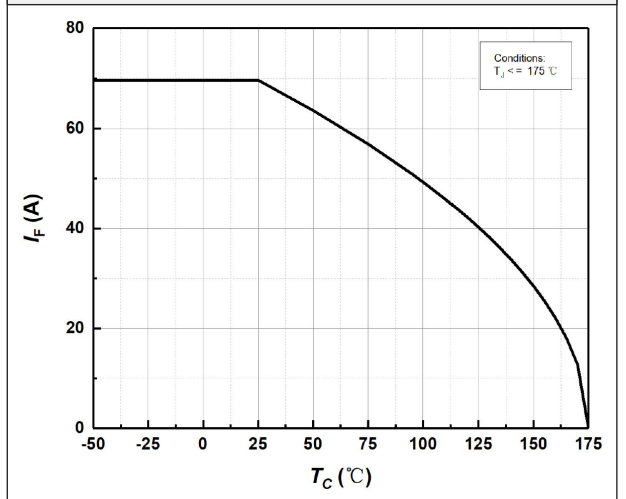

Figure 15. Transient Thermal Impedance

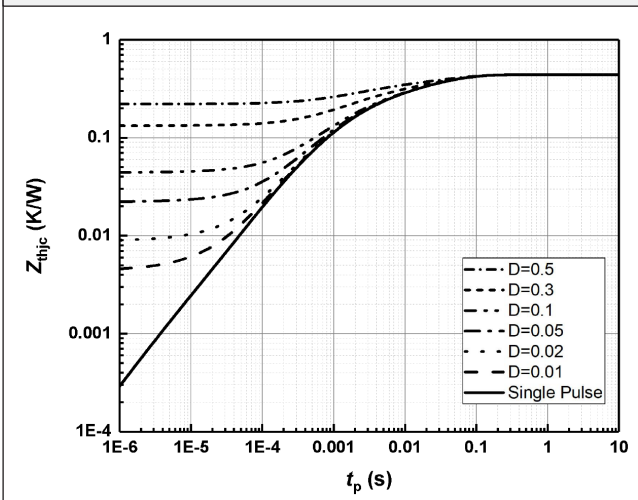

Figure 16. Maximum Power Dissipation Derating vs. Case Temperature

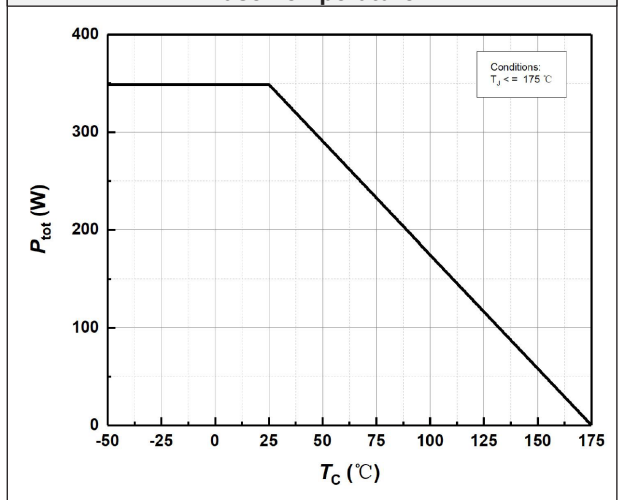

Figure 17. Output Capacitor Stored Energy

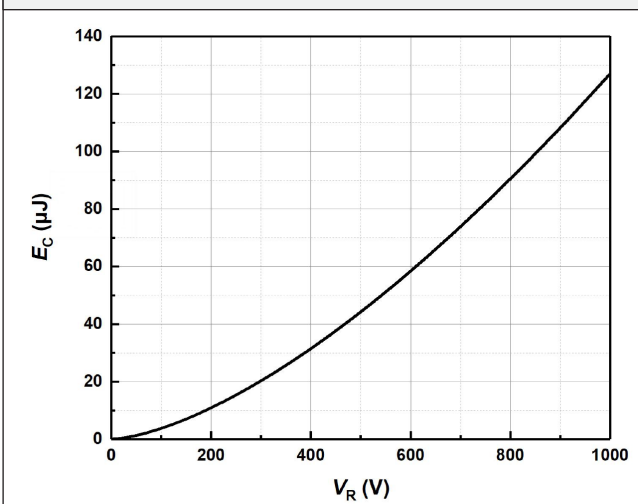
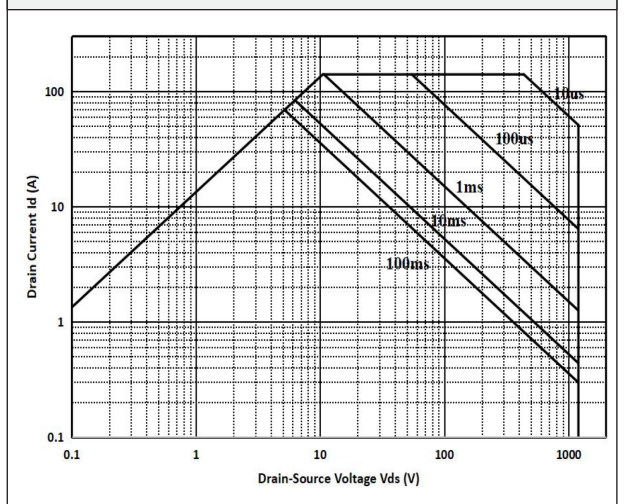

Figure 18. Safe Operating Area



Typical Performance Characteristics

Figure 19. Clamped Inductive Switching Energy vs. Drain Current ($V_{DD} = 600V$)

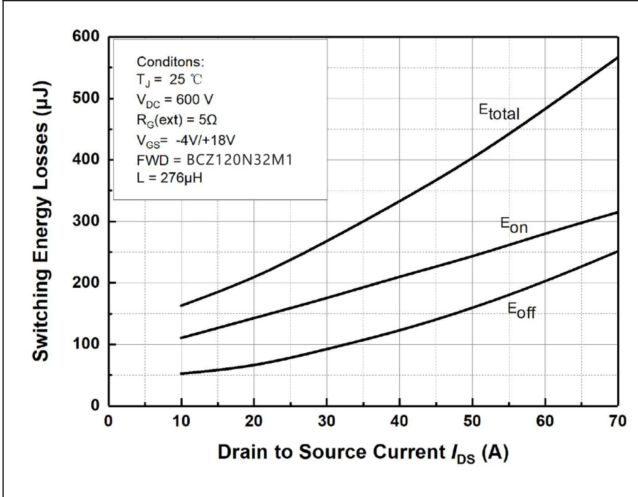

Figure 20. Clamped Inductive Switching Energy vs. Drain Current ($V_{DD} = 800V$)

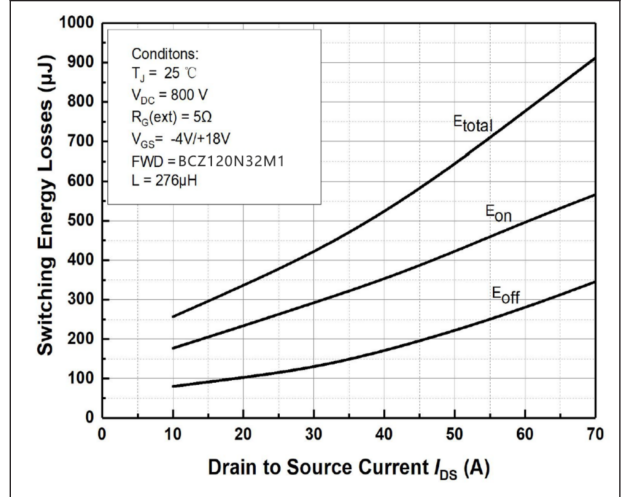

Figure 21. Clamped Inductive Switching Energy vs. $R_{G(ext)}$

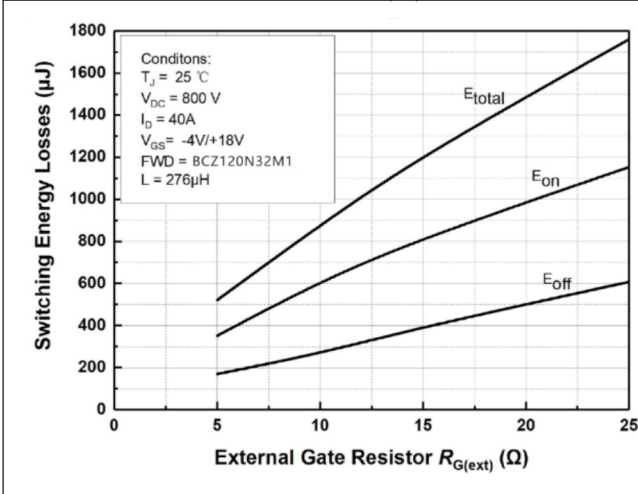
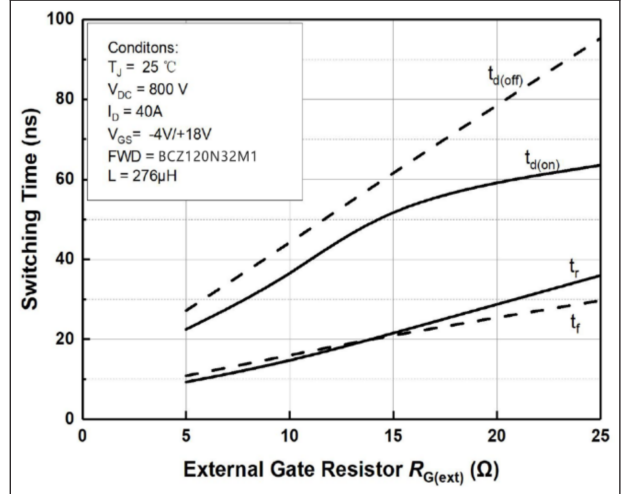
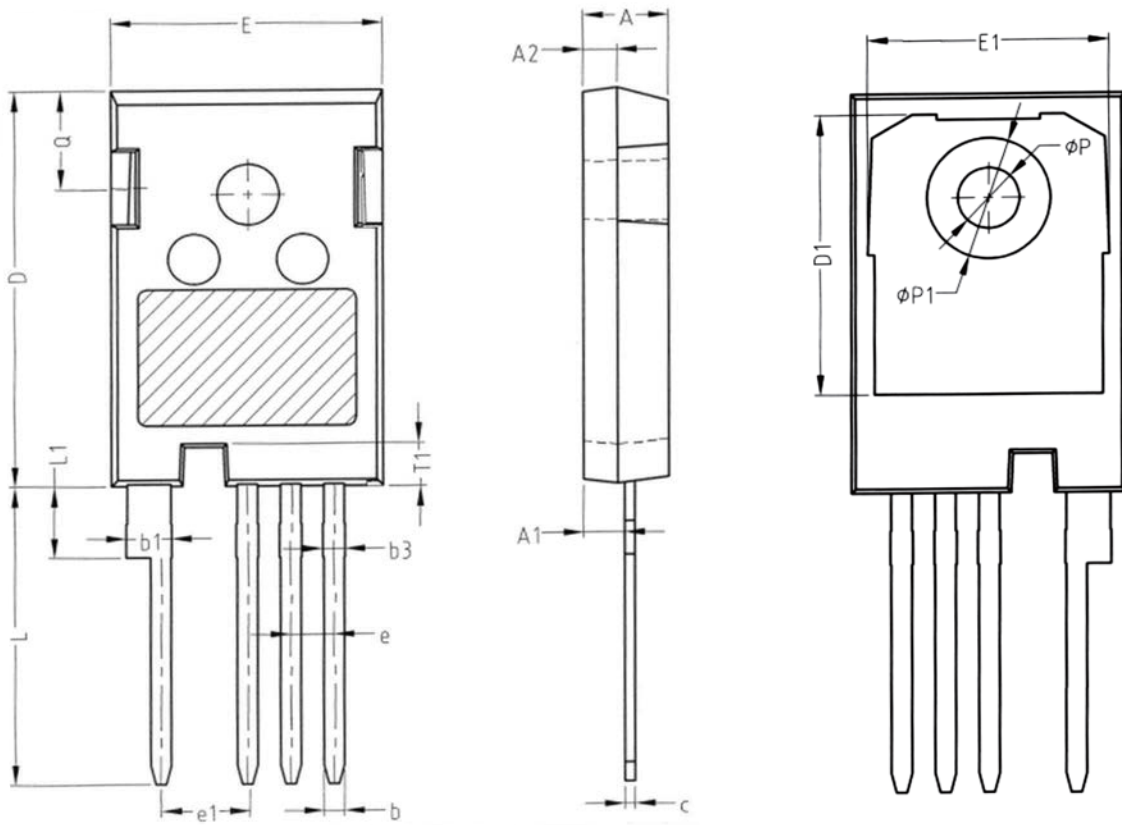

Figure 22. On-Resistance vs. Temperature



Package Outlines

TO247-4



SYMBOL	NM		
	MIN	NOM	MAX
A	4.80	5.00	5.20
A1	2.21	2.41	2.61
A2	1.80	2.00	2.20
b	1.06	1.21	1.36
b1	2.33	2.63	2.93
b3	1.07	1.30	1.60
c	0.51	0.61	0.75
D	23.30	23.45	23.60
D1	16.25	16.55	16.85
E	15.74	15.94	16.14
E1	13.72	14.02	14.32
T1	2.35	2.50	2.65
e	2.54 BSC		
e1	5.08 BSC		
Q	5.49	5.79	6.09
L	17.27	17.57	17.87
L1	3.99	4.19	4.39
ϕp	3.40	3.60	3.80
$\phi p1$	7.19 REF		

* Dimensions in millimeters

Package Marking and Ordering Information

Part Number	Top Marking	Package	Packing Method	Quantity
BCZ120N32W1	BCZ120N32W1	TO247-4L	Tube	30 units

Disclaimer

Bestirpower reserve the right to make changes, corrections, enhancements, modifications, and improvements to Bestirpower products and/or to this document at any time without notice.

The information given in this document shall in no event be regarded as a guarantee of conditions or characteristics. Bestirpower does not assume any liability for infringement of patents, copyrights, or other intellectual property rights of third parties by or arising from the use of Products or technical information described in this document.

This document is the property of Bestirpower Co., LTD., and not allowed to copy or transformed to other format if not under the authority approval.

© 2024 bestirpower – All rights reserved