

Low Noise, Low Power, Low Temperature Drift, 40 V Precise Voltage Reference

Features

- Low temperature drift:
 - A Grade: 3ppm/°C typ, 8ppm/°C max
 - B Grade: 2.8ppm/°C typ, 5ppm/°C max
- Long-Term stability:
 - 15ppm/1000hours(SOP-8L)
 - 10ppm/1000hours(MSOP-8L)
- High accuracy: $\pm 0.05\%$ max
- Multiple output voltage: 2.048V, 2.5V, 3V, 3.3V, 4.096V, 5V, 10V
- Low noise: 0.1Hz to 10Hz, 2.1ppm_P-P
- Strong driving capability: 20mA
- Wide supply range: 2.8V or $V_{OUT} + 0.3V$ to 40V
- Low quiescent current: 160 μ A
- Wide temperature range: -40°C to +125°C
- Package type: SOP-8L and MSOP-8L

Applications

- Precision Data Acquisition
- Precision Instruments
- Industrial Control
- Optical Communication
- Smart Grid

General Description

The AWS750XX are a series of precision voltage references providing a variety of output voltages with very low temperature coefficient and low noise. It is ideal for applications such as precision instruments and test equipment that require high resolution (>14bit) data acquisition. The performance of AWS750XX is guaranteed in a wide temperature range from -40°C to +125°C. Because of the low dropout feature of AWS750XX, the lowest supply voltage just 2.8V or 300mV higher than the output voltage. The maximum supply can be as high as 40V, which simplifies the design of system power supply. AWS750XX is a bandgap voltage reference, featuring outstanding temperature coefficient <3ppm/°C and the initial accuracy < $\pm 0.05\%$. This simplifies or sometimes eliminates the system calibration for most applications. AWS750XX provides SOP-8L and MSOP-8L packages, and are compatible with industry standard products.

Device Comparison

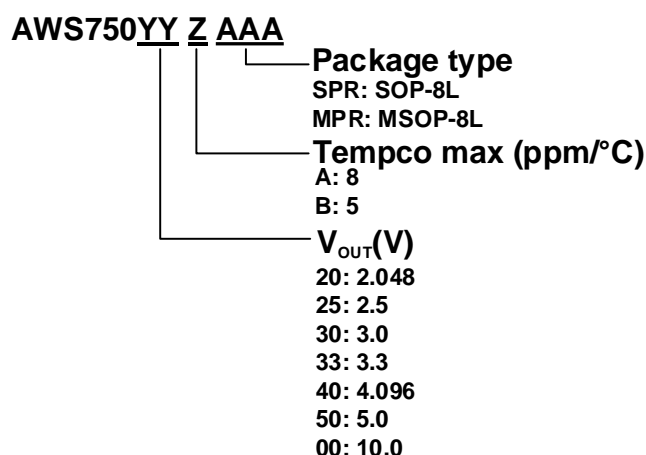

Typical Application Circuit

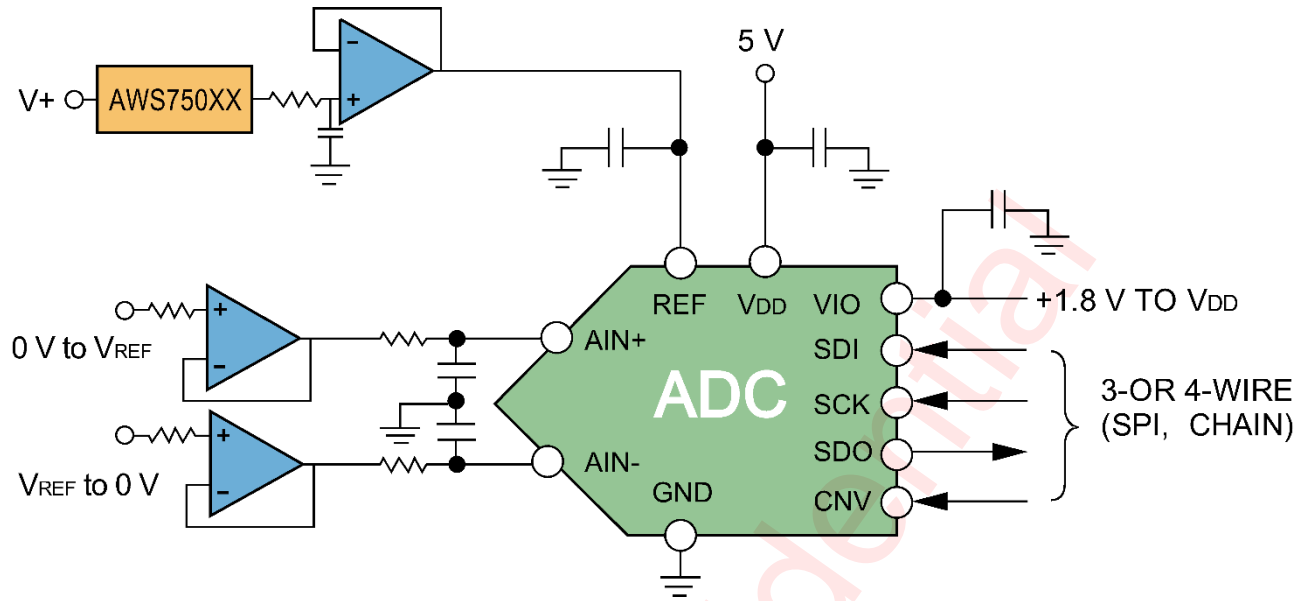

Figure 1. Typical Application Circuit of AWS750XX

All the trademarks mentioned in the document are the property of their owners.

Pin Configuration And Top Mark

SOP-8L

AWS750XXXSPR
(Top View)

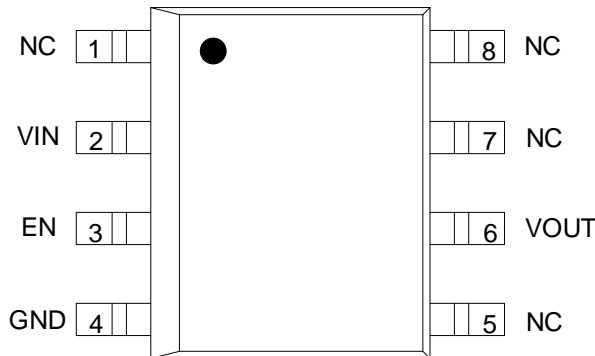

AWS750XXXSPR Marking
(Top View)

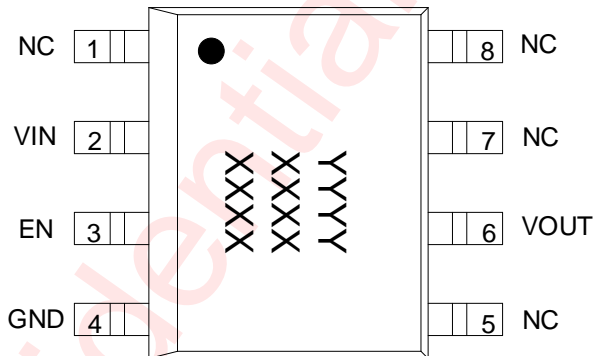

YYYY- Refer to Ordering Information of Marking
XXXX/XXXX - Production Tracing Code

MSOP-8L

AWS750XXXMPR
(Top view)

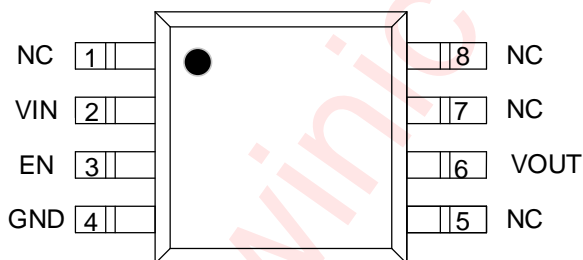

AWS750XXXMPR Marking
(Top view)

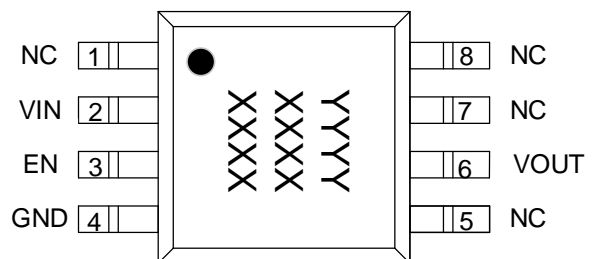

YYYY- Refer to Ordering Information of Marking
XXXX/XXXX - Production Tracing Code

Figure 2. Pin Configuration and Top Mark

Pin Definition

No.	NAME	DESCRIPTION
1,5,7,8	NC	Not connected.
2	VIN	Supply voltage.
3	EN	EN Input. This active low input powers down the device to 9 μ A. If left open, an internal pull-up resistor puts the part in normal operation. It is recommended to tie this pin high externally for best performance during normal operation.
4	GND	Ground.
6	VOUT	Output voltage.

Awinic Confidential

Functional Block Diagram

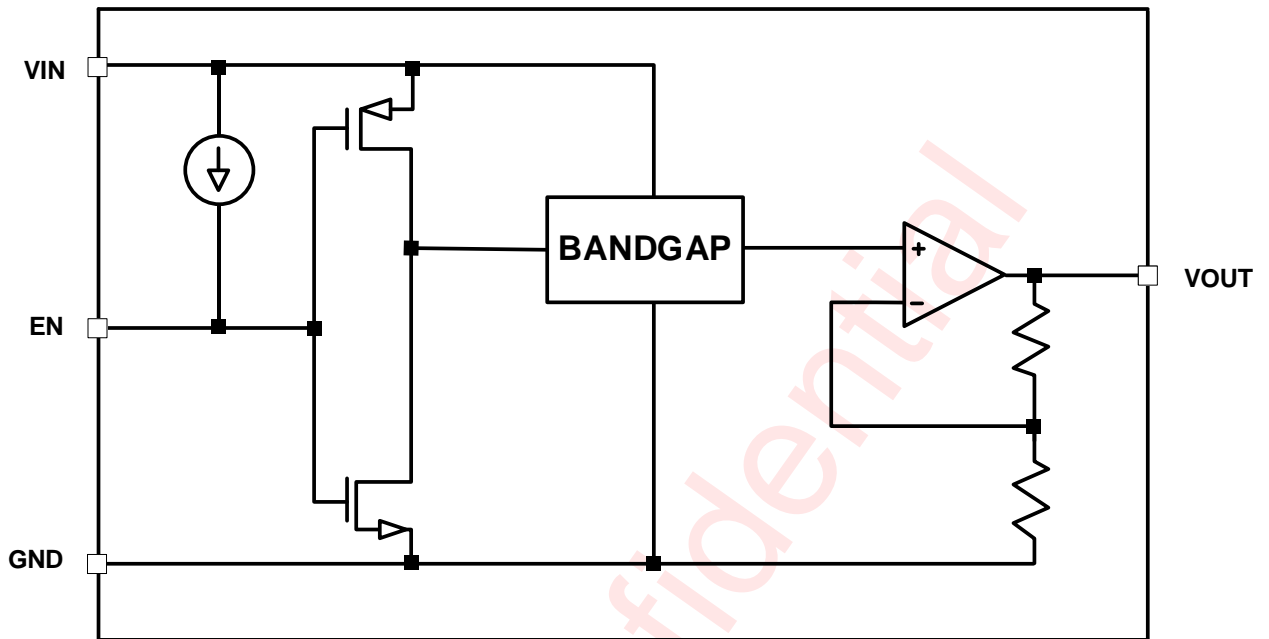

Figure 3. Functional Block Diagram

Typical Application Circuits

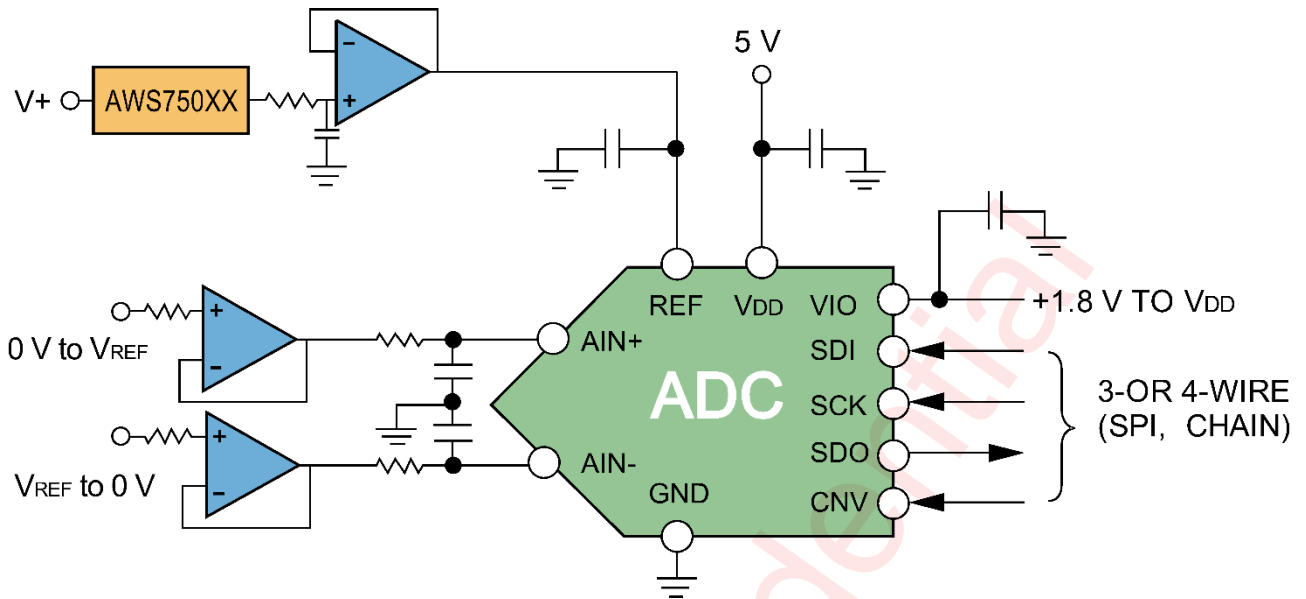

Figure 4. Typical Application Circuit of AWS750XX

Awinic Confidential

Ordering Information

Part Number	V _{out} (V)	Tempco Max (ppm/°C)	Temperature	Package	Marking	Moisture Sensitivity Level	Environmental Information	Delivery Form
AWS75020BSPR	2.048	5	-40°C~125°C	SOP-8L	KBDF	MSL1	ROHS+HF	4000 units/ Tape and Reel
AWS75020BMPR		5	-40°C~125°C	MSOP-8L	B6PT	MSL1	ROHS+HF	5000 units/ Tape and Reel
AWS75020ASPR		8	-40°C~125°C	SOP-8L	J1QP	MSL1	ROHS+HF	4000 units/ Tape and Reel
AWS75025BSPR	2.5	5	-40°C~125°C	SOP-8L	TCH8	MSL1	ROHS+HF	4000 units/ Tape and Reel
AWS75025BMPR		5	-40°C~125°C	MSOP-8L	3FSK	MSL1	ROHS+HF	5000 units/ Tape and Reel
AWS75025ASPR		8	-40°C~125°C	SOP-8L	0N98	MSL1	ROHS+HF	4000 units/ Tape and Reel
AWS75030BSPR	3.0	5	-40°C~125°C	SOP-8L	ZZL6	MSL1	ROHS+HF	4000 units/ Tape and Reel
AWS75030BMPR		5	-40°C~125°C	MSOP-8L	UGKL	MSL1	ROHS+HF	5000 units/ Tape and Reel
AWS75030ASPR		8	-40°C~125°C	SOP-8L	UJ5V	MSL1	ROHS+HF	4000 units/ Tape and Reel
AWS75033BSPR	3.3	5	-40°C~125°C	SOP-8L	KJ77	MSL1	ROHS+HF	4000 units/ Tape and Reel
AWS75033BMPR		5	-40°C~125°C	MSOP-8L	9015	MSL1	ROHS+HF	5000 units/ Tape and Reel
AWS75033ASPR		8	-40°C~125°C	SOP-8L	AGRV	MSL1	ROHS+HF	4000 units/ Tape and Reel
AWS75040BSPR	4.096	5	-40°C~125°C	SOP-8L	L204	MSL1	ROHS+HF	4000 units/ Tape and Reel
AWS75040BMPR		5	-40°C~125°C	MSOP-8L	RHPA	MSL1	ROHS+HF	5000 units/ Tape and Reel
AWS75040ASPR		8	-40°C~125°C	SOP-8L	P52L	MSL1	ROHS+HF	4000 units/ Tape and Reel
AWS75050BSPR	5.0	5	-40°C~125°C	SOP-8L	5X8E	MSL1	ROHS+HF	4000 units/ Tape and Reel
AWS75050BMPR		5	-40°C~125°C	MSOP-8L	8HKF	MSL1	ROHS+HF	5000 units/ Tape and Reel
AWS75050ASPR		8	-40°C~125°C	SOP-8L	6DSN	MSL1	ROHS+HF	4000 units/ Tape and Reel
AWS75000BSPR	10	5	-40°C~125°C	SOP-8L	27TL	MSL1	ROHS+HF	4000 units/ Tape and Reel
AWS75000BMPR		5	-40°C~125°C	MSOP-8L	V1J3	MSL1	ROHS+HF	5000 units/ Tape and Reel
AWS75000ASPR		8	-40°C~125°C	SOP-8L	FFX8	MSL1	ROHS+HF	4000 units/ Tape and Reel

Absolute Maximum Ratings^(NOTE1)

PARAMETERS		RANGE
Supply voltage		40V
Input voltage		-0.2V to 40V
Output short-circuit current to GND		±30mA
Maximum operating junction temperature T _{JMAX}		150°C
Junction-to-ambient thermal resistance θ_{JA}	SOP-8L	158°C/W
	MSOP-8L	190°C/W
Junction-to-case thermal resistance θ_{JC}	SOP-8L	43°C/W
	MSOP-8L	44°C/W
Operating free-air temperature range		-40°C to 125°C
Storage temperature T _{STG}		-65°C to 150°C
Maximum reflow temperature		260°C
Lead temperature (soldering 10seconds)		300°C
ESD		
Human body model (All pins, per JEDEC JS-001) ^(NOTE2)		±4.5kV
Charged device model (All pins, per JEDEC JS-002) ^(NOTE3)		±2kV

NOTE1: Conditions out of those ranges listed in "absolute maximum ratings" may cause permanent damages to the device. In spite of the limits above, functional operation conditions of the device should within the ranges listed in "recommended operating conditions". Exposure to absolute-maximum-rated conditions for prolonged periods may affect device reliability.

NOTE2: The human body model is a 100pF capacitor discharged through a 1.5kΩ resistor into each pin. Test method: ESDA/JEDEC JS-001-2023.

NOTE3: Test method: ESDA/JEDEC JS-002-2022.

Recommended Operating Conditions

PARAMETERS		MIN	MAX	UNIT
V _{IN}	Supply voltage	2.8	40	V
T _A	Operating junction temperature T _A	-40	125	°C

Electrical Characteristics

All test conditions: $V_{IN}=2.8V$ to $40V$, $I_{LOAD}=0$, $C_L=0.1\mu F$, $T_A = 25^\circ C$ for typical values (unless otherwise noted).

PARAMETER		TEST CONDITION	MIN	TYP	MAX	UNIT
V_{IN}	Supply voltage	$I_{LOAD}=5mA$, Output voltage Error $\leq 0.1\%$				
		AWS75020 $-40^\circ C \sim 125^\circ C$	2.8		40	V
		Others $-40^\circ C \sim 125^\circ C$	$V_{out}+0.3$		40	V
I_{SY}	Supply current	No load $-40^\circ C \sim 125^\circ C$		160	200	μA
		Shutdown (EN=GND) $-40^\circ C \sim 125^\circ C$		10	20	μA
Shutdown	Shutdown pin(EN)	Logic high input voltage $-40^\circ C \sim 125^\circ C$	2			V
		Logic high input current $-40^\circ C \sim 125^\circ C$	-1		1	μA
		Logic low Input voltage $-40^\circ C \sim 125^\circ C$			0.8	V
		Logic low Input current $-40^\circ C \sim 125^\circ C$	-1		1	μA
I_{SC}	Output short circuit current	$V_{OUT}=GND$ or V_{IN} $-40^\circ C \sim 125^\circ C$	14	20		mA
Output voltage						
V_{OUT}	Output voltage	AWS75020		2.048		V
		AWS75025		2.5		V
		AWS75030		3.0		V
		AWS75033		3.3		V
		AWS75040		4.096		V
		AWS75050		5		V
		AWS75000		10		V
Accuracy	Initial accuracy		-0.05		+0.05	%

Electrical Characteristics(Continued)

PARAMETER		TEST CONDITION	MIN	TYP	MAX	UNIT
Output voltage hysteresis		SOP-8L		50		ppm
		MSOP-8L		50		ppm
B Grade	Tempco max	-40°C ~125°C		2.8	5	ppm/°C
A Grade		-40°C ~125°C		3	8	ppm/°C
Noise	Voltage noise	0.1Hz to 10Hz		2.1		ppm_P-P
e _n	Voltage noise density	AWS75020,1kHz		167		nV/√Hz
		AWS75025,1kHz		185		nV/√Hz
		AWS75030,1kHz		225		nV/√Hz
		AWS75033,1kHz		233		nV/√Hz
		AWS75040,1kHz		348		nV/√Hz
		AWS75050,1kHz		380		nV/√Hz
		AWS75000,1kHz		774		nV/√Hz
Line regulation		AWS75020: V _{IN} =2.8V~40V Others: V _{IN} =V _{OUT} +0.3V~40V -40°C ~125°C		0.1	3	ppm/V
Load regulation		-10mA<I _{LOAD} <10mA T _A = 25°C		0.8	20	ppm/mA
		-40°C ~125°C			35	
Turn-on time		0.1% settling, C _L =0.1μF		200		μs
LTD	Long-term stability ¹	1000hours, SOP-8L		15		ppm/1000 hours
		1000hours, MSOP-8L		10		ppm/1000 hours

¹ Data collected using devices soldered onto the test board.

Typical Characteristics

At $V_{IN}=2.8V$ to $40V$, $I_{LOAD}=0$, $C_L=0.1\mu F$, $T_A = 25^\circ C$, unless otherwise noted.

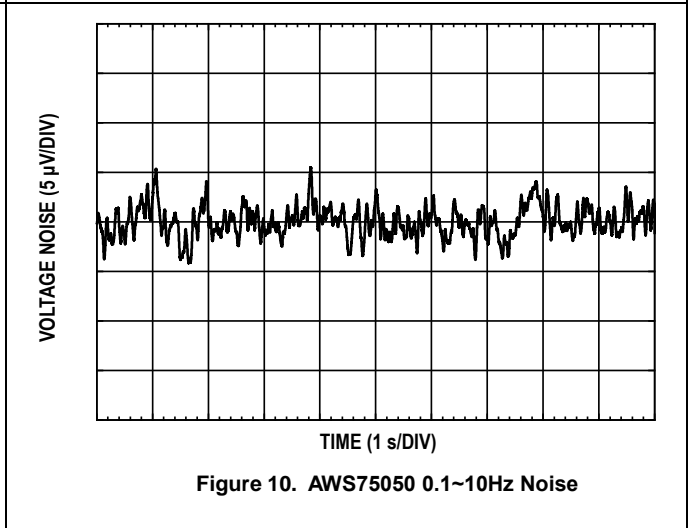
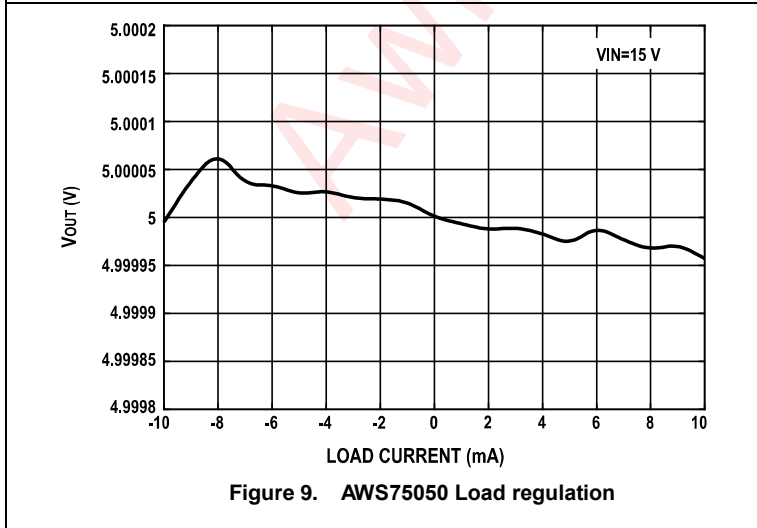
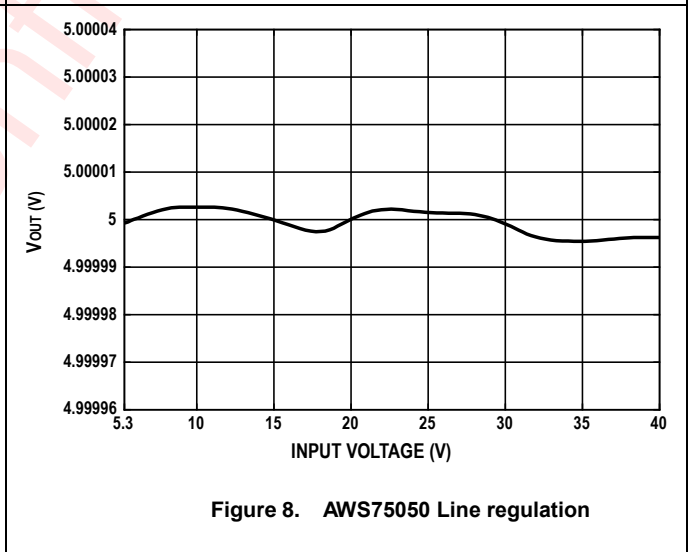
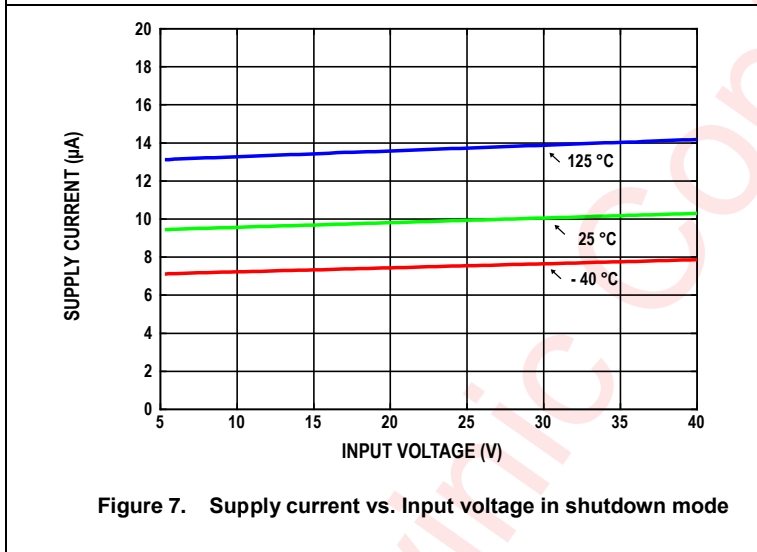
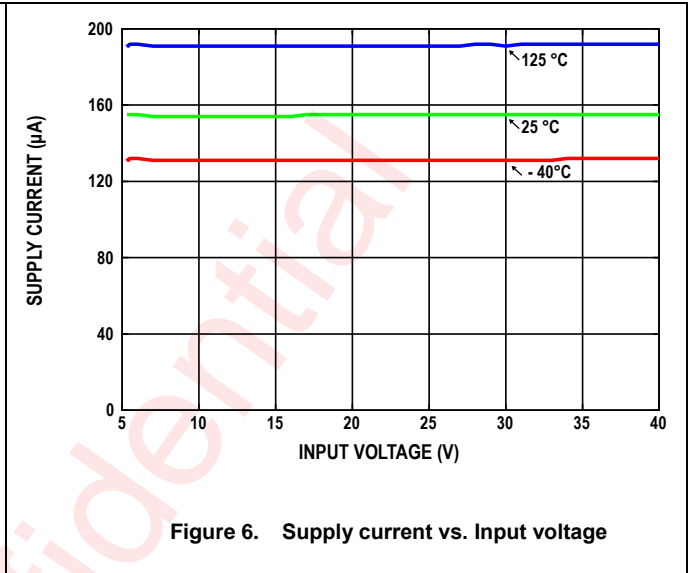
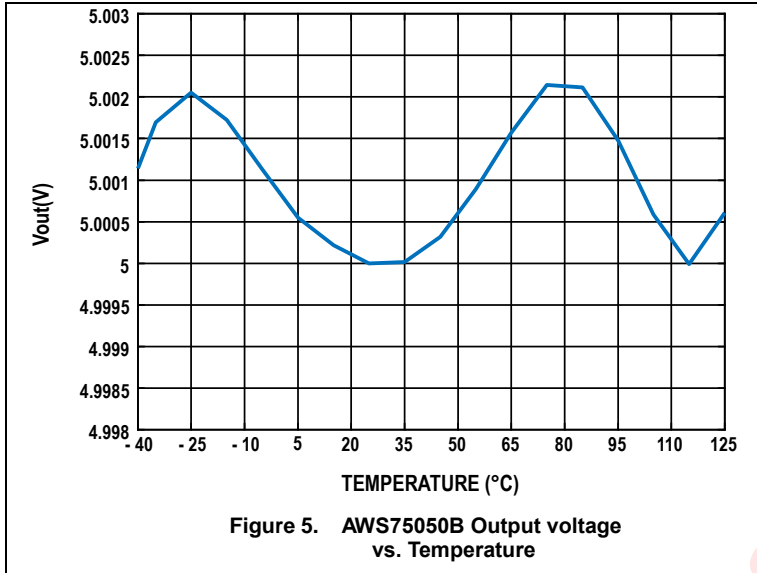

Typical Characteristics(Continued)

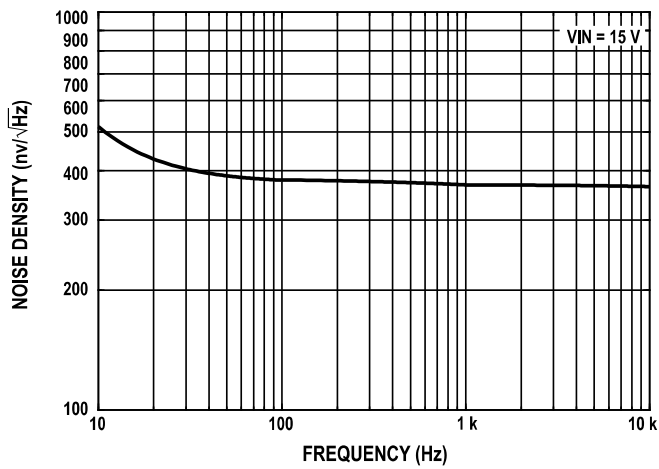

Figure 11. AWS75050 Voltage noise density vs. Frequency

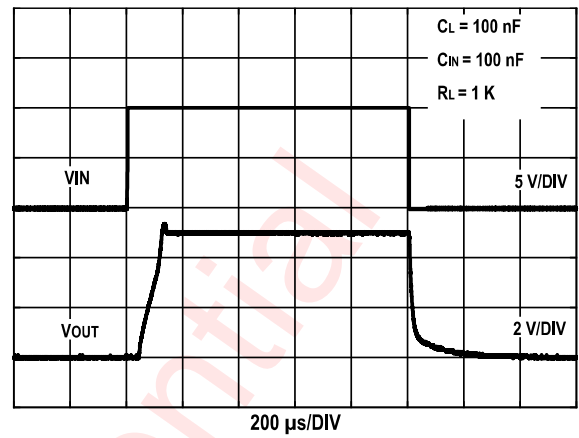

Figure 12. Power-on/off response

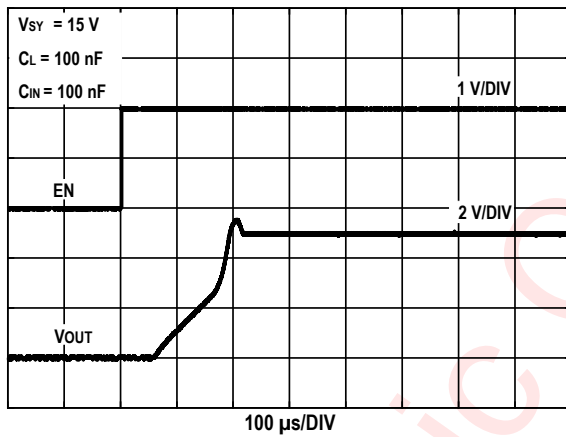

Figure 13. Enable response

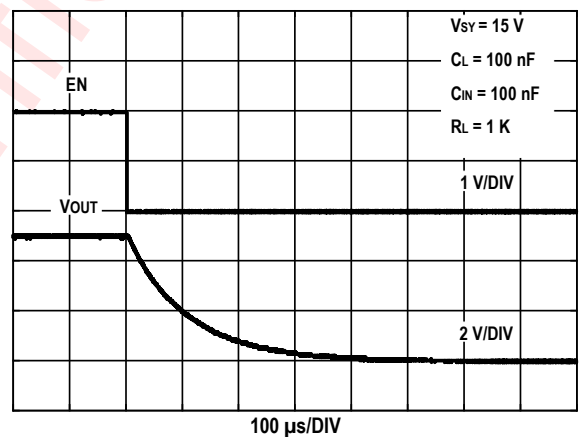

Figure 14. Disable response

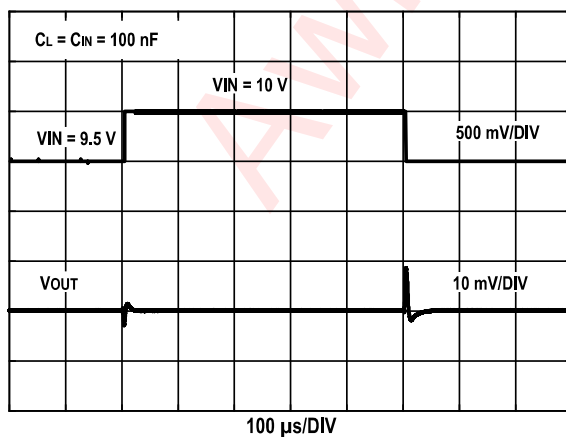

Figure 15. Line transient response

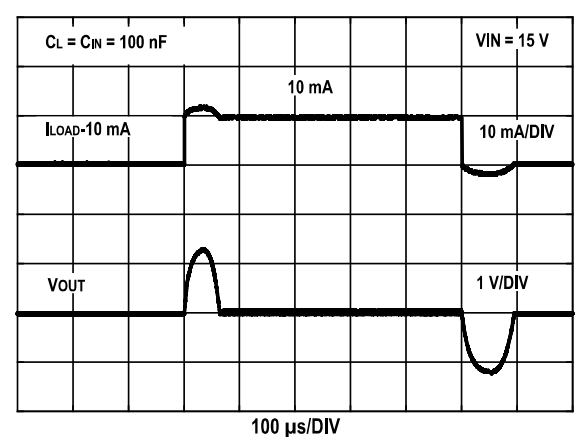

Figure 16. AWS75050 Load transient

Typical Characteristics(Continued)

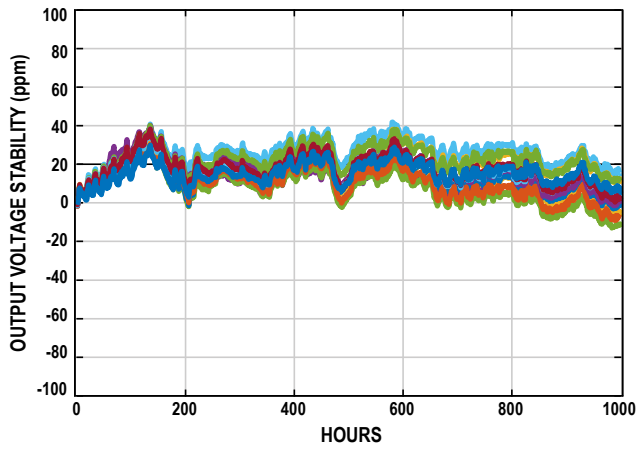

Figure 17. Long-term stability (MSOP-8L)

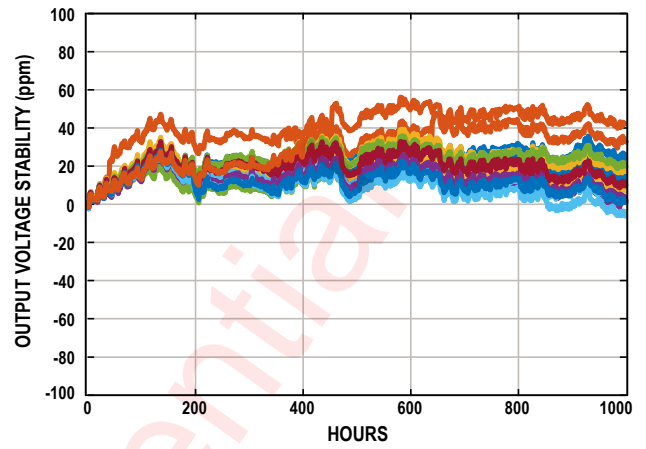

Figure 18. Long-term stability (SOP-8L)

Detailed Functional Description

Temperature Coefficient

The change of output voltage over the operating temperature range is normalized by the output voltage at 25°C, and expressed in ppm/°C as

$$dV_{OUT}/dT = \frac{V_{OUT(max)} - V_{OUT(min)}}{V_{OUT(25)} \times (T2 - T1)} \times 10^6$$

Where:

$V_{OUT(25)}$: Output voltage at 25°C.

$V_{OUT(min)}$: The lowest output voltage over temperature T1 to T2 range.

$V_{OUT(max)}$: The highest output voltage over temperature range T1 to T2.

For AWINIC Micro voltage references, temperature T1 is -40°C, and T2 is +125°C.

Long-term Stability

This is the measurement of the change in output voltage of the measured device at 25°C after 1000 hours (approximately 42 days) of operation at a constant ambient temperature. Generally measured in ppm. Long-term stability is not only affected by variations in the device itself, but also by soldering and board materials. Long-term stability generally exhibits a logarithmic characteristic, therefore the change in the second 1000 hours will be much smaller than the change in the first 1000 hours.

$$LTD = \frac{V_{OUT(t0)} - V_{OUT(t1)}}{V_{OUT(t0)}} \times 10^6$$

where:

$V_{OUT(t0)}$: Output voltage at 25°C at Time 0.

$V_{OUT(t1)}$: Output voltage at 25°C at Time 1 after 1000 hours of operation under constant ambient temperature.

Thermal Hysteresis

The change of output voltage after the device is cycled through temperatures from +25°C to -40°C to +125°C and back to +25°C. This is a typical value from a sample of parts put through such a cycle. It is normally in ppm using the following equation:

$$TH = \frac{V_{OUT(25)} - V_{OUT(TC)}}{V_{OUT(25)}} \times 10^6$$

where:

$V_{OUT(25)}$: Output voltage at 25°C.

$V_{OUT(TC)}$: Output voltage at 25°C after the temperature cycle.

Line Regulation

The change in output voltage due to a specified change in input voltage. It includes the effects of self-heating. Line regulation is expressed in either percent per volt, parts per million per volt, or microvolts per volt change in input voltage, such as ppm/V.

Load Regulation

The change in output voltage due to a specified change in load current. It includes the effects of self-heating. Load regulation is expressed in either microvolts per milliampere or parts per million per milliampere, such as ppm/mA.

Theory of Operation

AWS750XX is a family of low power, low noise and precision voltage reference, which were developed in 40V BCD process. **Figure 19** shows its simplified schematic. The bandgap circuit is the key building block, which was carefully optimized and trimmed in order to deliver the outstanding low temperature co-efficient. The output amplifier provides sufficient driving capability. EN enables or disables the part for normal operation.

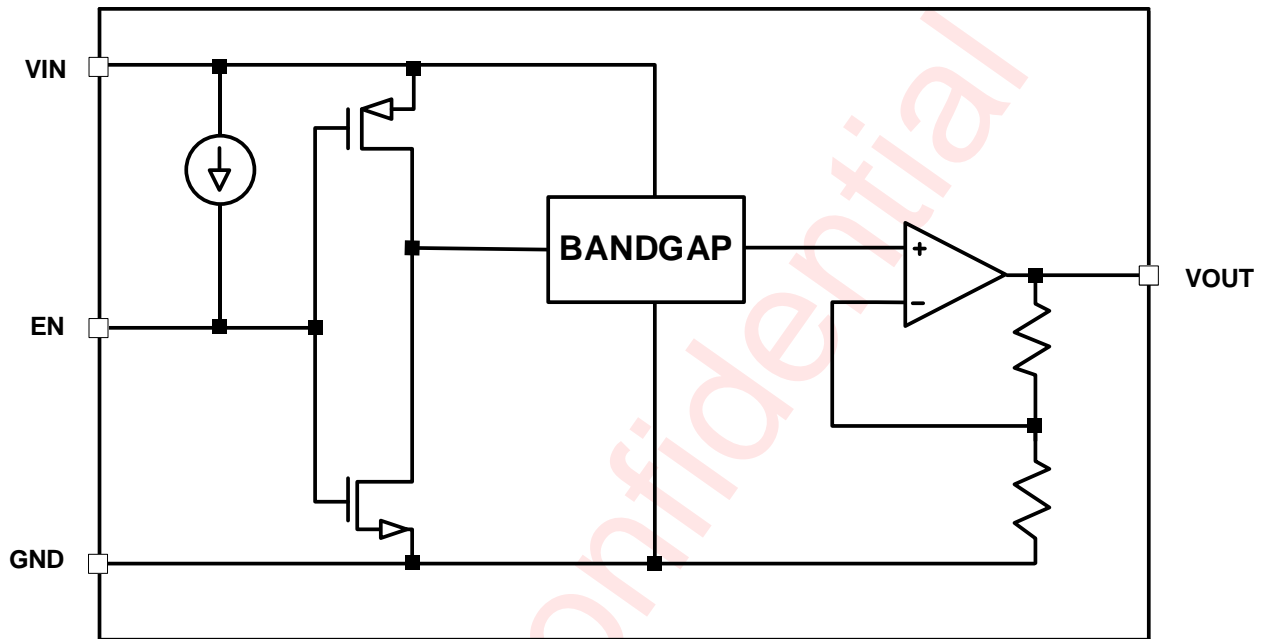

Figure 19. Simplified schematic of AWS750XX

Application Information

Typical Configuration

Typical configuration of modern series voltage reference is straight forward. AWS750XX normally requires a load cap of $0.1\mu\text{F}$ ~ $10\mu\text{F}$ between V_{OUT} and GND. An input bypass cap of $1\mu\text{F}$ is desirable for better power supply rejection as show in **Figure 20**.

Note the load capacitor ranges from $0.1\mu\text{F}$ to $10\mu\text{F}$. Excessive load cap might lead to output settling problem or sometimes oscillation, as well as slower start up. The equivalent series resistance (ESR) of cap is recommended to be less than 1.5Ω in order to ensure circuit stability. Optimal capacitance value depends on the load condition of the part. For example, if AWS750XX directly drives SAR ADC, $1\mu\text{F}$ or $2.2\mu\text{F}$ offers good noise and settling performance.

It is recommended to use surface-mounted ceramic capacitors (such as X5R, X7R). If an electrolytic capacitor is used at the output, a $0.1\mu\text{F}$ ceramic capacitor should be placed in parallel to reduce the overall ESR at the output. In addition, the capacitors' operating temperature range and voltage rating shall be at least as wide as the system requirement.

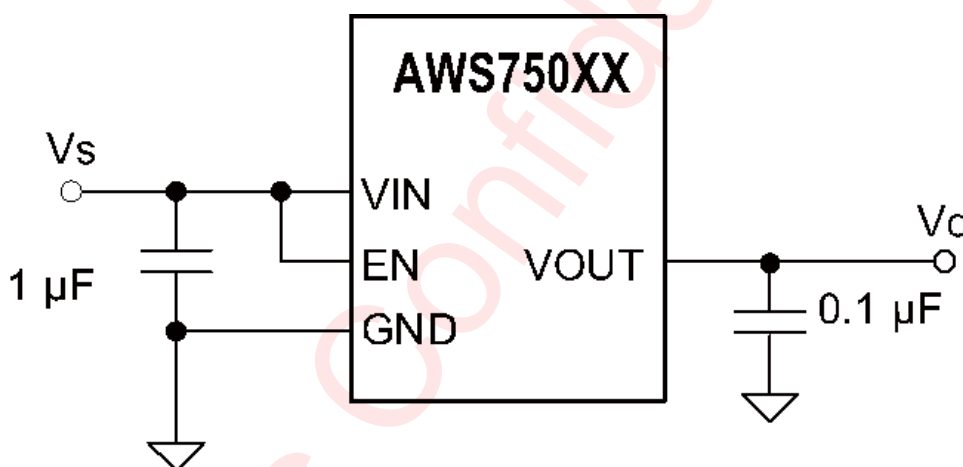

Figure 20. AWS750XX Typical Configuration

Power on and Shutdown mode

Figure 12 shows the power-on process of AWS750XX. The value of the load capacitor affects the turn-on time. In general, the larger the load cap, the longer the settling time. Settling to higher accuracy sees exponentially longer turn-on time.

For power consumption sensitive applications, AWS750XX offers useful shut down feature. The part burns just $10\mu\text{A}$ in shutdown mode, the shutdown procedure can be found in **Figure 13** and **Figure 14**. Shutdown mode is controlled by pin 3 (EN). The voltage threshold of this pin is around 1.2V and compatible with CMOS/TTL logic.

There is an internal weak pull-up current $0.22\mu\text{A}$ on chip. If the pin is left floating, its voltage rises close to V_{IN} and the part is enabled. Due to the weak pull-up nature, it is recommended that the EN pin be pulled high externally for normal operation to prevent accidental shut down.

Supply Voltage

AWS750XX has a wide supply voltage range. The lowest supply voltage for AWS75020 is 2.8V, while in other versions it can be as low as output voltage plus 300mV. Supply voltage of 10V higher is widely used in many applications, such as industrial control systems. AWS750XX's highest supply voltage of 40V might simplify system power supply design.

It is recommended to power AWS750XX by linear power supplies, such as LDO, in order to ensure high frequency performances.

Noise Performance

The noise generated by AWS75050 is typical 10 μ V_{P-P} over the 0.1Hz to 10Hz band as shown in Figure 10. The noise measurement employs a band-pass filter with corner frequencies of 0.1Hz and 10Hz.

Power Dissipation

AWS750XX is a low power device with a typical supply current of 160 μ A. For high supply voltage and/or heavy load, it is necessary to calculate the power dissipation of the device, and take into account the performance changes caused by it. The temperature of the device increases according to the equation below.

$$T_J = P_D \times \theta_{JA} + T_A$$

where:

T_J =Junction temperature (°C)

T_A =Ambient temperature (°C)

P_D =Power dissipated (W)

θ_{JA} =Junction-to-ambient thermal resistance (°C/W)

The AWS750XX junction temperature must not exceed the absolute maximum rating of 150°C.

Voltage Reference Noise to ADC Resolution

In general, the voltage reference's 0.1Hz to 10Hz noise should be within ADC's 1/2 LSB. With the same resolution, the larger the full scale voltage, the lower the noise requirement to the voltage reference as can be found in **Table 1**. AWS750XX is able to be used as 16-bit ADC voltage reference.

Table 1 ADC Resolution vs. Voltage Reference Noise

Resolution (bit)	0.1Hz to 10Hz Noise (μ V _{P-P})	
	2.5V Full scale voltage	5V Full scale voltage
8	4,882.8	9,765.6
10	1,220.7	2,441.4
12	305.2	610.4
14	76.3	152.6
16	19.1	38.1
18	4.8	9.5

Negative Output Precision Voltage References

In some systems, negative output voltage reference is needed, **Figure 21** shows a simple way to get a negative precision voltage reference by using AWS750XX. Extra resistor R is needed together with the negative power supply. AWS75050 is used to verify the circuit, and the power supplies are $\pm 5V$ ($V_S=5V$, $V_{ee}=-5V$). The current of resistor R is $(V_{ee}-V_o)/R$, and its power dissipation is $(V_{ee}-V_o)^2/R$. In order to obtain highest performance, the user shall minimize on chip heat generation. When the voltage drop on R is high, proper value of R should be picked. Meanwhile, resistor R won't impact the negative voltage reference's temperature coefficient.

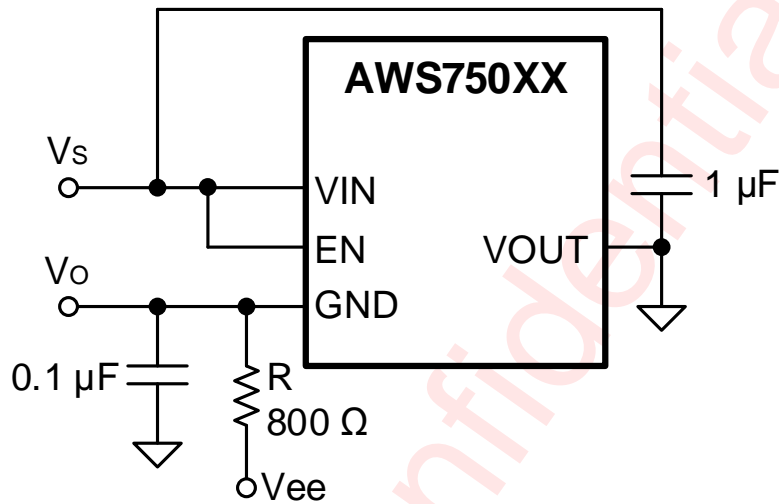

Figure 21. Using AWS750XX to generate negative output precision voltage reference

PCB Layout Consideration

To obtain the optimal performance of AWS750XX, PCB layout should be considered carefully. Here are some guidelines:

1. Place the power-supply bypass capacitor as closely as possible to the supply and ground pins. The recommended value of this bypass capacitor is from $1\mu\text{F}$ to $10\mu\text{F}$. If necessary, additional decoupling capacitance can be added to compensate for noisy or high-impedance power supplies.
2. The output must be decoupled with a bigger than $0.1\mu\text{F}$ capacitor. For better noise performance, the recommended ESR on the output capacitor is from 1Ω to 1.5Ω . For even lower noise, a larger capacitor in parallel or an RC filter can be added.
3. Use large area ground plane if possible. Keep fast-changing or high-frequency interference signals far from AWS750XX.

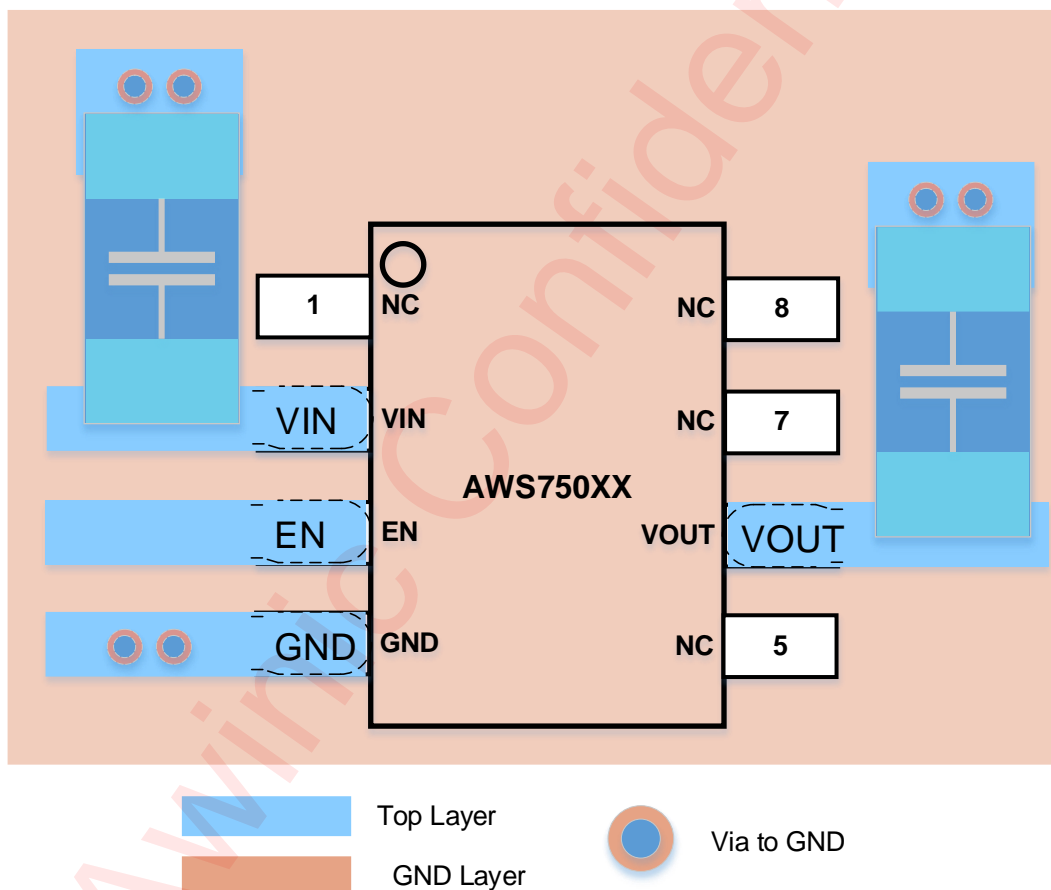
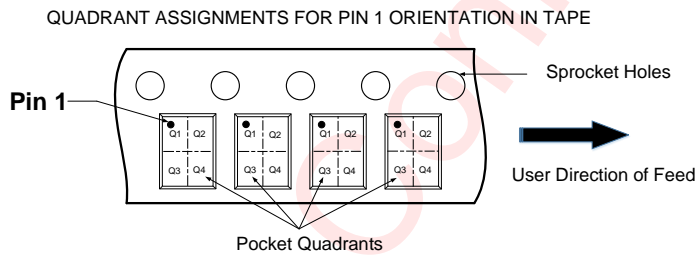
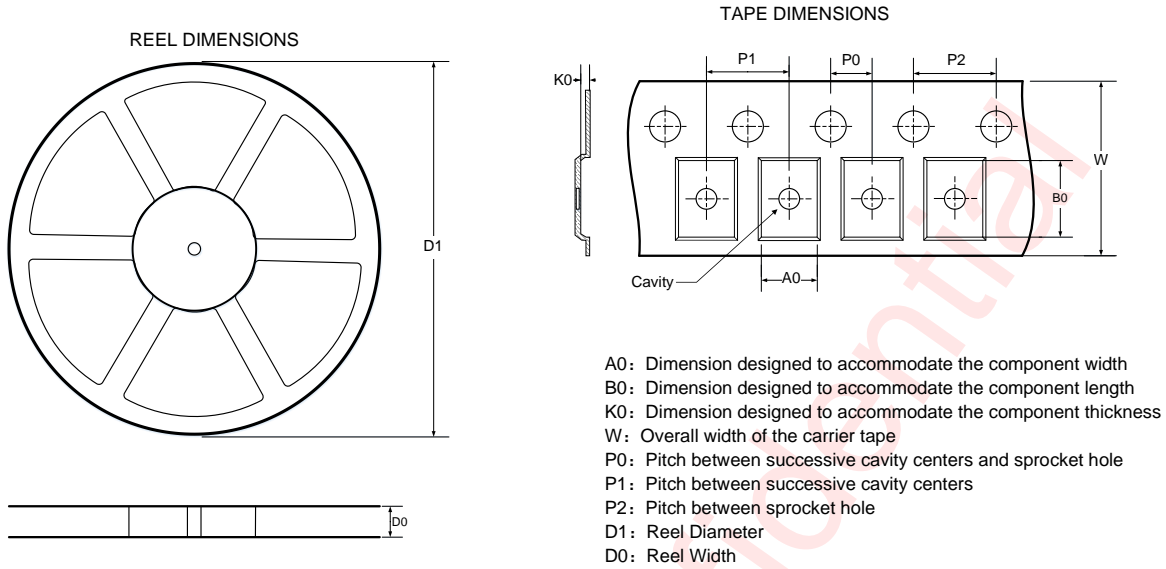

Figure 22. External Components Placements and PCB Layout Example

Tape And Reel Information

SOP-8L



Note: The above picture is for reference only. Please refer to the value in the table below for the actual size

DIMENSIONS AND PIN1 ORIENTATION

D1 (mm)	D0 (mm)	A0 (mm)	B0 (mm)	K0 (mm)	P0 (mm)	P1 (mm)	P2 (mm)	W (mm)	Pin1 Quadrant
330.00	12.00	6.50	5.20	2.00	2.00	8.00	4.00	12.00	Q1

All dimensions are nominal

MSOP-8L

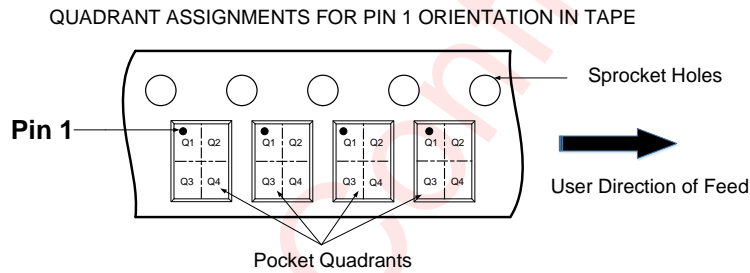
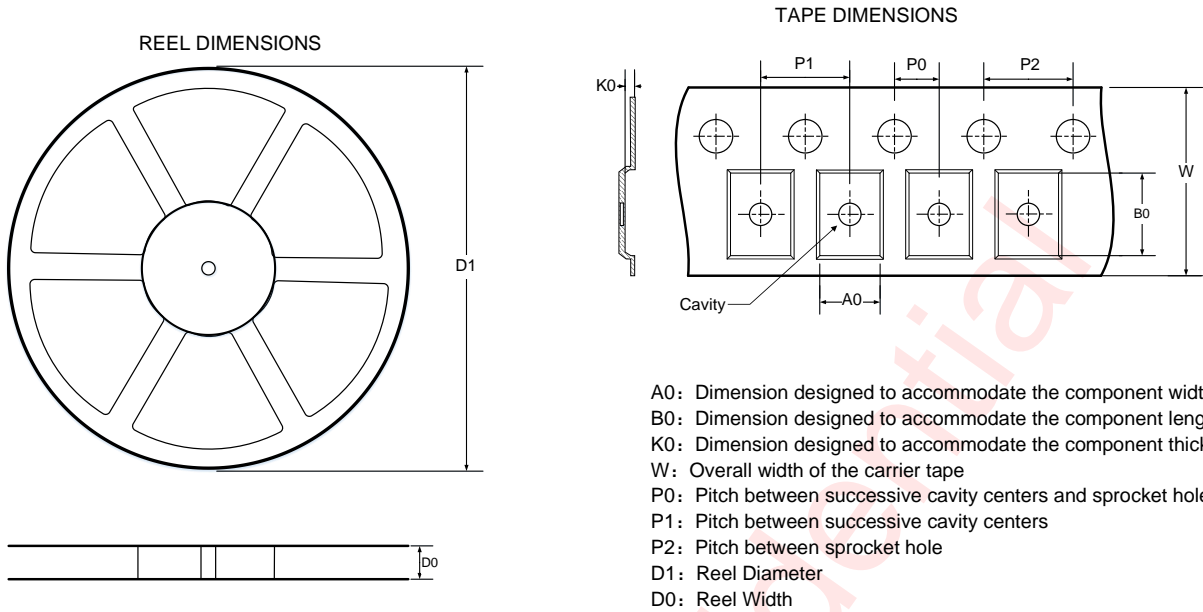

Note: The above picture is for reference only. Please refer to the value in the table below for the actual size

DIMENSIONS AND PIN1 ORIENTATION

D1 (mm)	D0 (mm)	A0 (mm)	B0 (mm)	K0 (mm)	P0 (mm)	P1 (mm)	P2 (mm)	W (mm)	Pin1 Quadrant
330.00	12.00	5.20	3.30	1.20	2.00	8.00	4.00	12.00	Q1

All dimensions are nominal

Package Description

SOP-8L

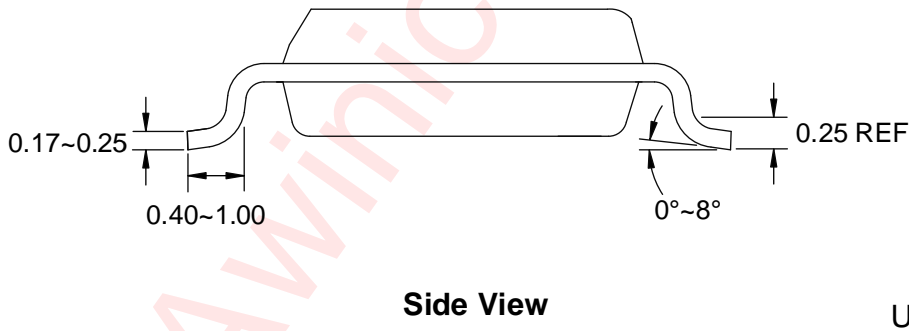
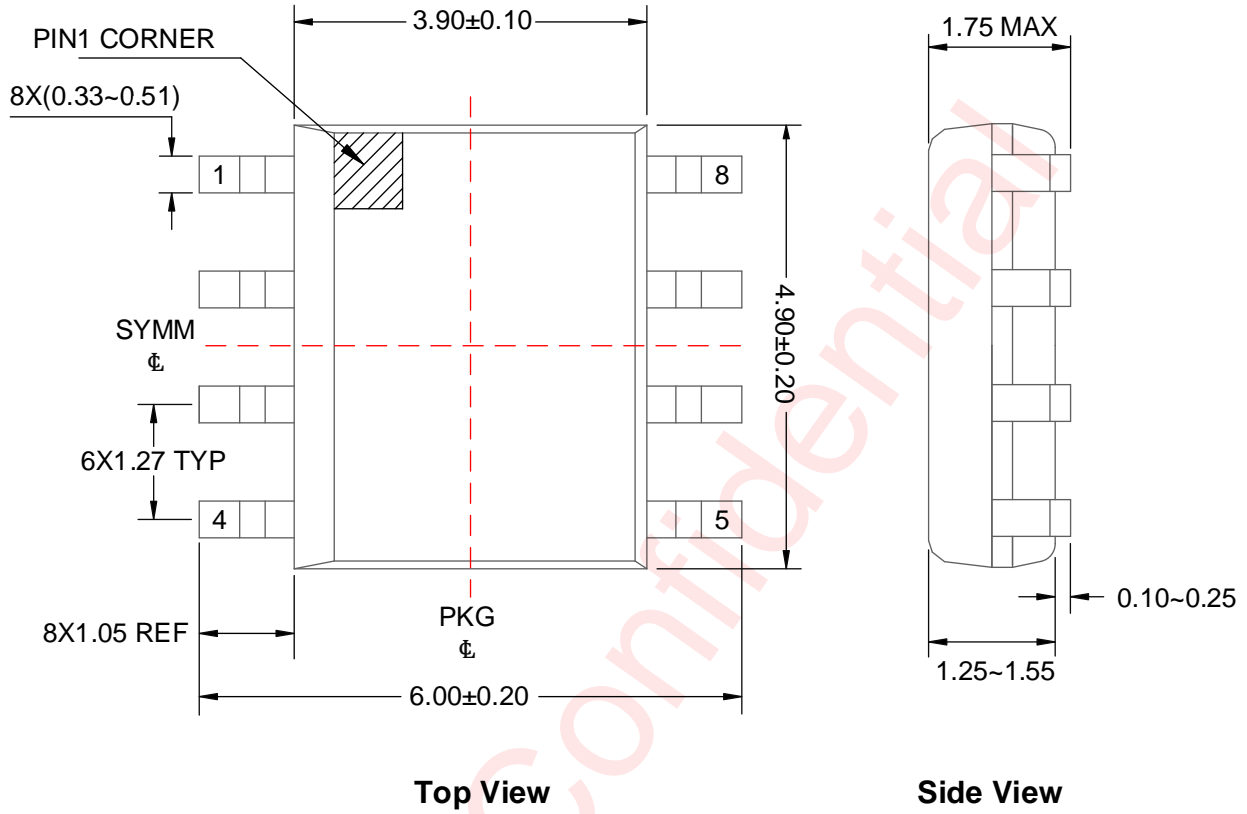

Unit: mm

MSOP-8L

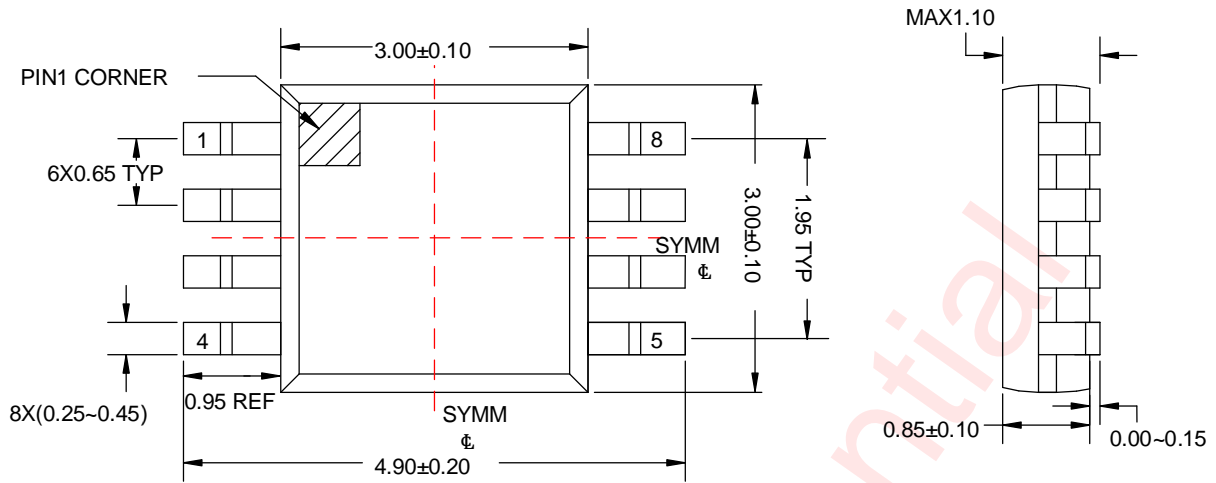

Top View

Side View

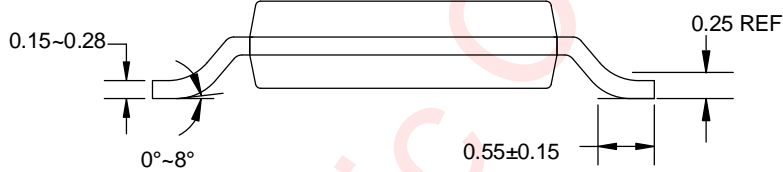

Side View

Unit: mm

Land Pattern Data

SOP-8L

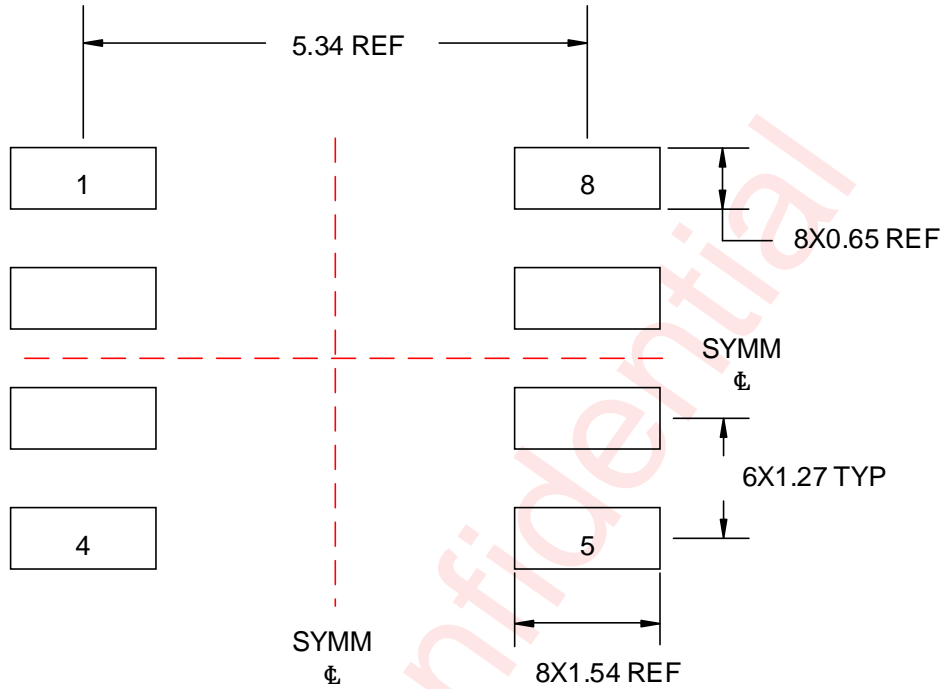

0.05 MAX
All AROUND

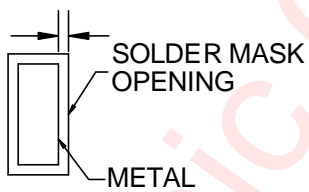

NON SOLDER MASK DEFINED

0.05 MIN
All AROUND

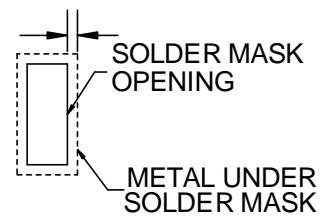

SOLDER MASK DEFINED

Unit: mm

MSOP-8L

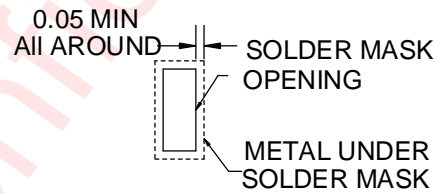
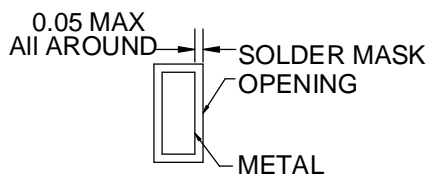
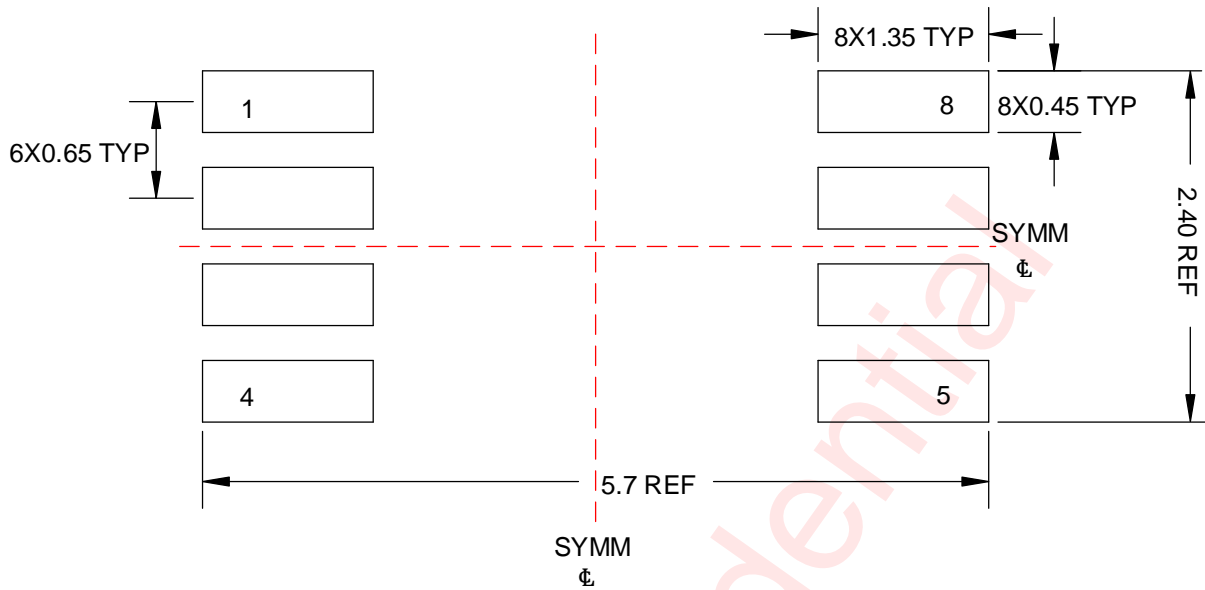

NON SOLDER MASK DEFINED

SOLDER MASK DEFINED

Unit: mm

Revision History

Version	Date	Change Record
V1.0	Dec. 2024	Datasheet V1.0 released

Awinic Confidential

Disclaimer

Information in this document is believed to be accurate and reliable. However, Shanghai AWINIC Technology Co., Ltd (AWINIC Technology) does not give any representations or warranties, expressed or implied, as to the accuracy or completeness of such information and shall have no liability for the consequences of use of such information.

AWINIC Technology reserves the right to make changes to information published in this document, including without limitation specifications and product descriptions, at any time and without notice. Customers shall obtain the latest relevant information before placing orders and shall verify that such information is current and complete. This document supersedes and replaces all information supplied prior to the publication hereof.

AWINIC Technology products are not designed, authorized or warranted to be suitable for use in medical, military, aircraft, space or life support equipment, nor in applications where failure or malfunction of an AWINIC Technology product can reasonably be expected to result in personal injury, death or severe property or environmental damage. AWINIC Technology accepts no liability for inclusion and/or use of AWINIC Technology products in such equipment or applications and therefore such inclusion and/or use is at the customer's own risk.

Applications that are described herein for any of these products are for illustrative purposes only. AWINIC Technology makes no representation or warranty that such applications will be suitable for the specified use without further testing or modification.

All products are sold subject to the general terms and conditions of commercial sale supplied at the time of order acknowledgement.

Nothing in this document may be interpreted or construed as an offer to sell products that is open for acceptance or the grant, conveyance or implication of any license under any copyrights, patents or other industrial or intellectual property rights.

Reproduction of AWINIC information in AWINIC data books or data sheets is permissible only if reproduction is without alteration and is accompanied by all associated warranties, conditions, limitations, and notices. AWINIC is not responsible or liable for such altered documentation. Information of third parties may be subject to additional restrictions.

Resale of AWINIC components or services with statements different from or beyond the parameters stated by AWINIC for that component or service voids all express and any implied warranties for the associated AWINIC component or service and is an unfair and deceptive business practice. AWINIC is not responsible or liable for any such statements.