

DPDT USB Switch With Over Voltage Protection

Features

- USB 2.0 Hi-speed DPDT switch
- Typical -3dB bandwidth: 1.0 GHz
- Reverse blocking back-to-back MOSFETs
- Over voltage protection : 3.83V typical
- 24V DC protection on D+ and D- Ports
- +30V surge protection on D+ and D-
- Supply voltage range: 2.7V to 5.5V
- 5.8Ω switch on-resistance typical
- C_{ON}: 6pF typical
- I_{CC}: 38μA typical
- WLCSP 1.57mmX1.17mmX0.574mm-12B package

Applications

- Smartphones
- Tablets

General Description

The AW35743G is a Hi-Speed USB 2.0(480Mbps) DPDT (Double Pole Double Throw) switch with integrated protection for USB D+ and D-, it can be configured as a dual 1:2 or 2:1 switch.

The AW35743G protection on the D+/D- pins can tolerate up to 24V DC, when D+ or D- voltage is greater than the OVP(Over-Voltage Protection) threshold, the switch will be automatically shutoff to protect downstream devices.

The device operates over 2.7V to 5.5V supply range with independent control bits for each switch pair and an on/off enable pin for shutdown mode. Additional features include low switch on resistance and capacitance along with a fault flag to alert the system processor to overvoltage fault events.

The AW35743G is available in a WLCSP 1.57mmX1.17mmX0.574mm-12B package.

Typical Application Circuit

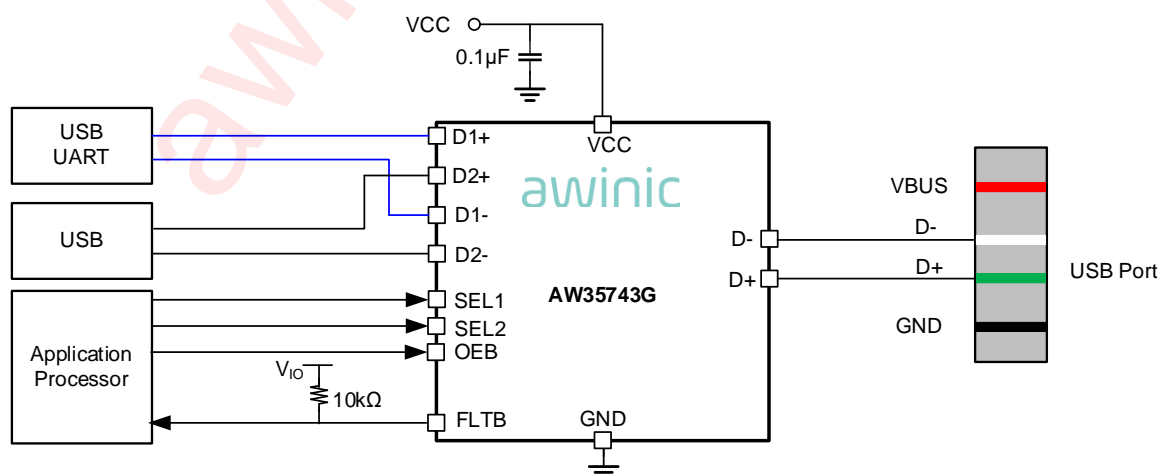

Figure 1 Typical Application Circuit of AW35743G

Pin Configuration And Top Mark

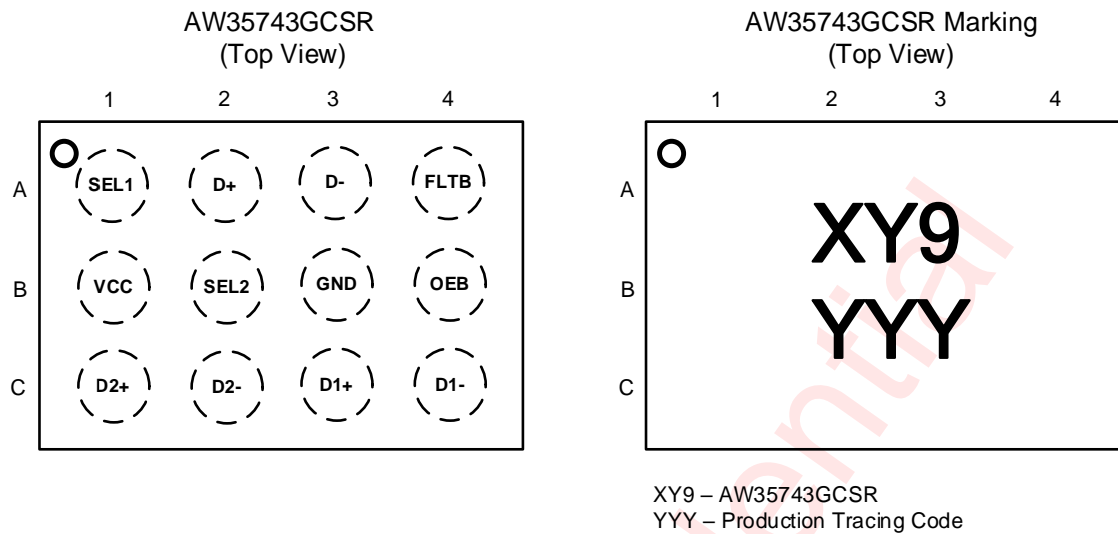

Figure 2 Pin Configuration And Top Mark

Pin Definition

PIN	NAME	DESCRIPTION
A1	SEL1	Switch select1, active high
A2	D+	Common high speed data port, differential +
A3	D-	Common high speed data port, differential -
A4	FLT B	Fault indicator output, active low, open drain
B1	VCC	Supply voltage
B2	SEL2	Switch select2, active high
B3	GND	Ground
B4	OEB	Output enable, active low
C1	D2+	Multiplexed high speed data port2, differential +
C2	D2-	Multiplexed high speed data port2, differential -
C3	D1+	Multiplexed high speed data port1, differential +
C4	D1-	Multiplexed high speed data port1, differential -

Pin Functions

OEB	SEL1	SEL2	D- CONNECTION	D+ CONNECTION
H	X	X	High-Z	High-Z
L	L	L	D- to D1-	D+ to D1+
L	L	H	D- to D1-	D+ to D2+
L	H	L	D- to D2-	D+ to D1+
L	H	H	D- to D2-	D+ to D2+

Functional Block Diagram

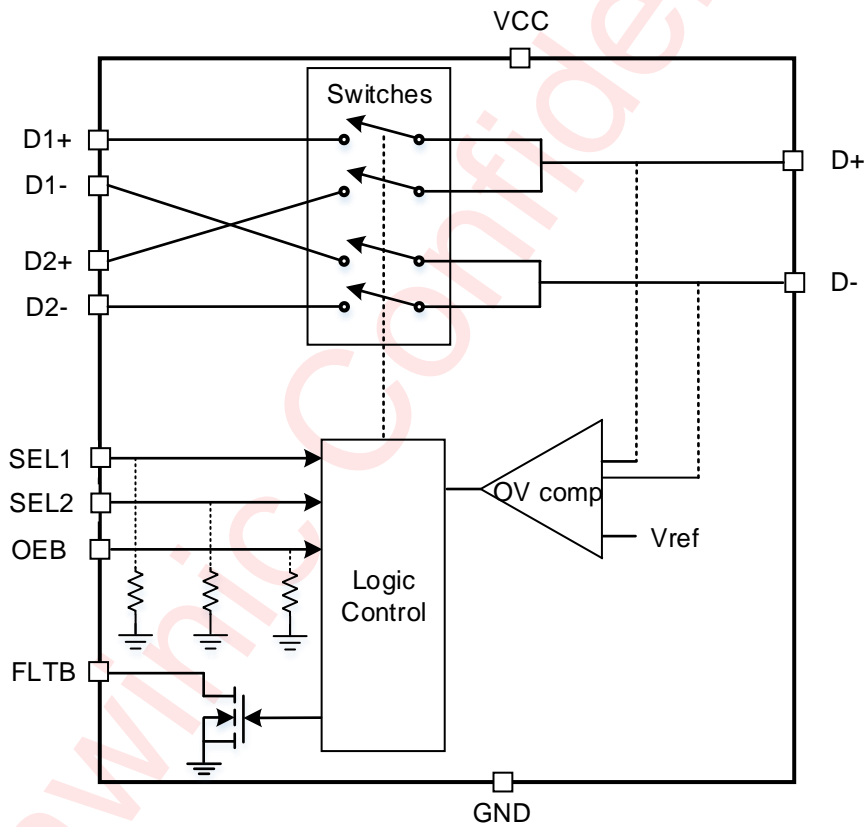

Figure 3 Functional Block Diagram

Typical Application Circuits

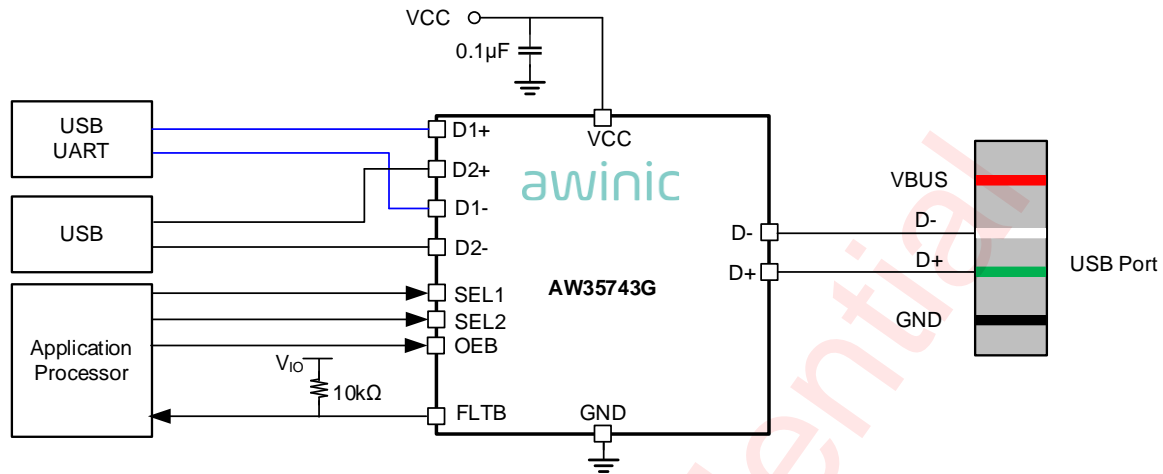

Figure 4 Typical Application Circuit of AW35743G

Notice for Typical Application Circuits:

1. The AW35743G has internal 5.8-M Ω pull down resistors on SEL1, SEL2, and OEB, so no external resistors are required on the logic pins.
2. Internal pull-down resistor on SEL1 and SEL2 pins ensures the D1+ and D1- channels are selected by default.
3. If FLTB is not used, it can be left floating.

Ordering Information

Part Number	Temperature	Package	Marking	Moisture Sensitivity Level	Environmental Information	Delivery Form
AW35743GCSR	-40°C~85°C	WLCSP 1.57mmX1.17mm X0.574mm-12B	XY9	MSL1	ROHS+HF	3000 units/ Tape and Reel

Absolute Maximum Ratings^(NOTE1)

PARAMETERS		RANGE
Supply voltage range VCC		-0.3V to 6V
Input/Output DC voltage(D+, D-)		-0.3V to 24V
Input/Output DC voltage(D1+, D1-, D2+, D2-)		-0.3V to 6V
Input voltage range	SEL1, SEL2, OEB	-0.3V to 6V
Output voltage range	FLTB	-0.3V to 6V
Junction-to ambient thermal resistance θ_{JA}		95°C/W
Maximum operating junction temperature T_{JMAX}		150°C
Operating free-air temperature range		-40°C to 85°C
Storage temperature T_{STG}		-65°C to 150°C
Lead temperature (soldering 10 seconds)		260°C
ESD		
Human Body Model (All pins, per JEDEC JS-001) ^(NOTE2)		±2kV
Charged Device Model (All pins, per JEDEC JS-002) ^(NOTE3)		±1kV
Latch-up		
Test condition: JEDEC78E		±200mA

NOTE1: Conditions out of those ranges listed in “absolute maximum ratings” may cause permanent damages to the device. In spite of the limits above, functional operation conditions of the device should within the ranges listed in “recommended operating conditions”. Exposure to absolute-maximum-rated conditions for prolonged periods may affect device reliability.

NOTE2: The human body model is a 100pF capacitor discharged through a 1.5kΩ resistor into each pin. Test method: ESDA/JEDEC JS-001-2017.

NOTE3: Test method: ESDA/JEDEC JS-002-2018.

Recommended Operating Conditions

PARAMETER		MIN	MAX	UNIT
V _{CC}	Supply voltage	2.7	5.5	V
V _{I/O}	Analog input/output voltage(D _±)	0	24	V
	Analog input/output voltage(Dn _±)	0	3.6	
V _I	Digital input voltage(SEL1, SEL2, OEB)	0	5.5	V
T _A	Operating free-air temperature T _A	-40	85	°C

Electrical Characteristics

$V_{CC}=3.3V$ $T_A=25^{\circ}C$ for typical values (unless otherwise noted).

PARAMETER		TEST CONDITION	MIN	TYP	MAX	UNIT
V_{CC}	Supply voltage		2.7	3.3	5.5	V
I_{CC}	Active supply current	OEB=0V SEL1, SEL2=0V $0V < V_{D\pm} < 3.6V$		38		μA
I_{CC_PD}	Standby supply current	OEB= V_{CC} SEL1, SEL2=0V		0.5		μA
DC Characteristics						
R_{ON}	On-state resistance	$V_{I/O}=0.4V$, $I_{SINK}=8mA$		5.8		Ω
ΔR_{ON}	On-state resistance match between channels	$V_{I/O}=0.4V$, $I_{SINK}=8mA$		0.1		Ω
$R_{ON(FLAT)}$	ON-state resistance flatness	$V_{I/O}=0V$ to $0.4V$, $I_{SINK}=8mA$		0.1		Ω
I_{OFF}	I/O pin OFF leakage current on D+/D-	$V_{D\pm} = 0V$ or $3.6V$ $V_{D1\pm}$ or $V_{D2\pm} = 3.6V$ or $0V$			10	μA
		$V_{D\pm} = 0V$ or $24V$ $V_{D1\pm}$ or $V_{D2\pm} = 0V$			420	μA
I_{ON}	ON leakage current on D+/D-	$V_{D\pm} = 0V$ or $3.6V$ $V_{D1\pm}$ and $V_{D2\pm} = high-Z$		2	10	μA
Digital Characteristics						
V_{IH}	Input logic high	SEL1, SEL2, OEB	1.4			V
V_{IL}	Input logic low	SEL1, SEL2, OEB			0.4	V
V_{OL}	Output logic low	FLTB $I_{OL}=1mA$			0.5	V
R_{PD}	Internal pull-down resistor on digital input pins			5.8		$M\Omega$
Protection						
V_{OVP_TH}	OVP threshold	D+/D- rising	3.66	3.83	4	V
V_{OVP_HYST}	OVP threshold hysteresis	D+/D- falling		120		mV
t_{OVP}	OVP Protection Response time	$V_{D\pm} = 1V$ to $10V$ step		50		ns
t_{OVPR}	OVP Protection Recovery Time	$V_{D\pm} = 10V$ to $1V$ step		1.5		μs

Electrical Characteristics (Continued)V_{CC}=3.3V T_A= 25°C for typical values (unless otherwise noted).

PARAMETER		TEST CONDITION	MIN	TYP	MAX	UNIT
Dynamic Characteristics						
C _{ON}	IO pins ON capacitance	V _{D±} = 0 or 3.3 V, f = 240 MHz, switch ON		6		pF
O _{ISO}	Differential off isolation	R _L = 50 Ω C _L = 5 pF f = 100 kHz, switch OFF		-60		dB
		R _L = 50 Ω C _L = 5 pF f = 240MHz, switch OFF		-20		dB
X _{TALK}	Channel to channel crosstalk	R _L = 50 Ω C _L = 5 pF f = 100 kHz, switch ON		-60		dB
BW	-3dB bandwidth	R _L = 50 Ω, switch ON		1.0		GHz
t _{switch}	Switching time between channels (SEL1, SEL2 to output)	V _{D±} = 0.8 V		2.5	5	μs
t _{on}	Device turn on time (OEB to output)	R _L = 50 Ω C _L = 5 pF, V _{CC} = 2.7 V to 5.5 V		22		μs
t _{off}	Device turn off time (OEB to output)			53		ns
t _{pd}	Propagation delay	V _{D±} = 0.4 V R _L = 50 Ω, C _L = 5 pF, V _{CC} = 2.7 V to 5.5 V		200		ps

Timing Diagram

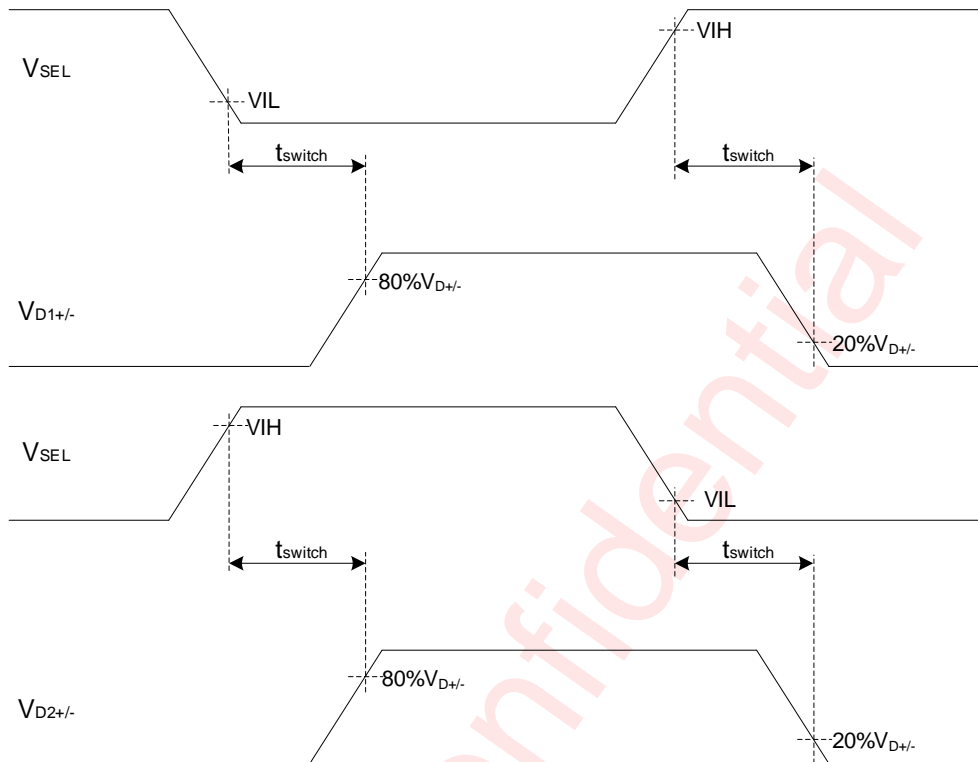

Figure 5 Switching Time Between Channels

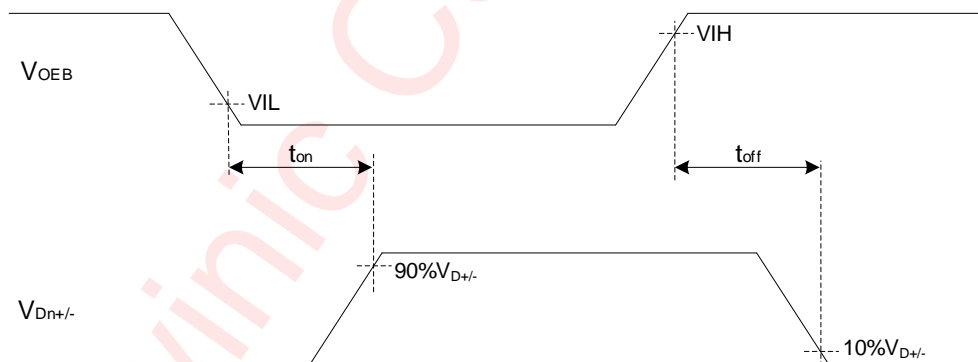

Figure 6 Device Turn On Time

Timing Diagram (Continued)

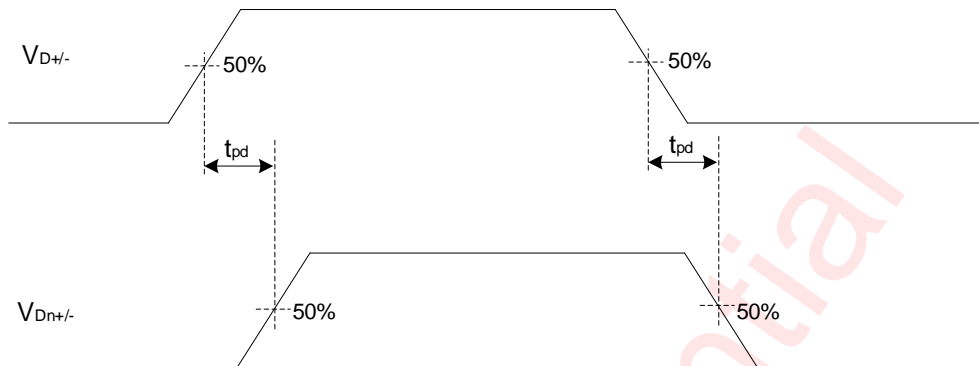

Figure 7 Propagation delay

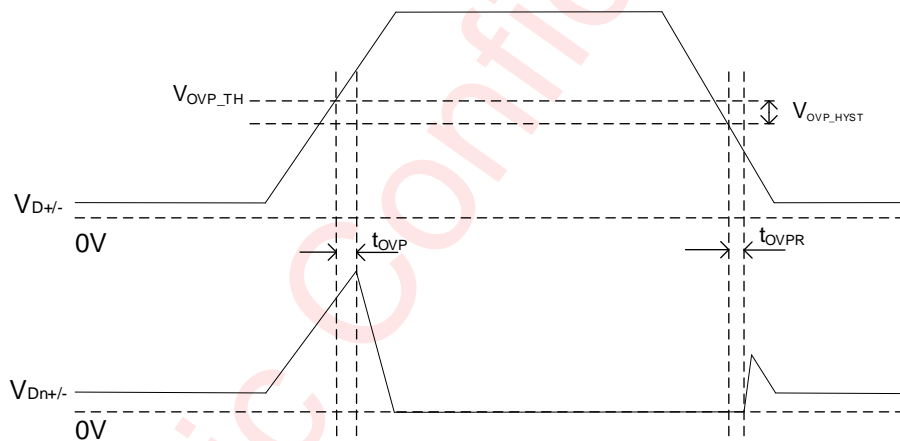

Figure 8 Overvoltage Protection

Application Information

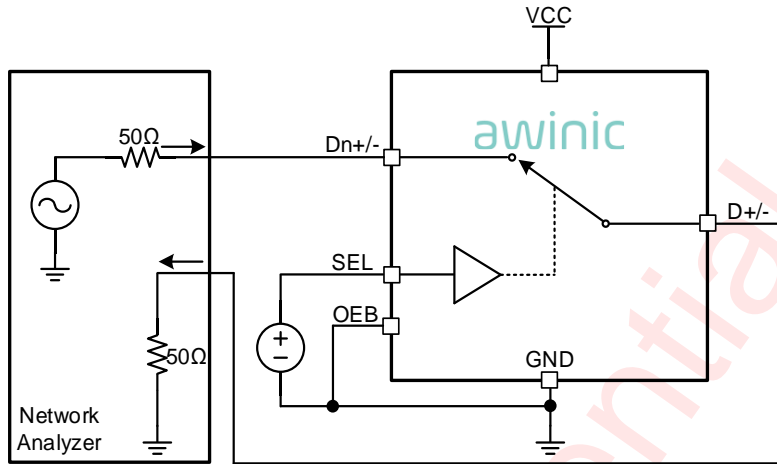

Figure 9 BW and Insertion Loss

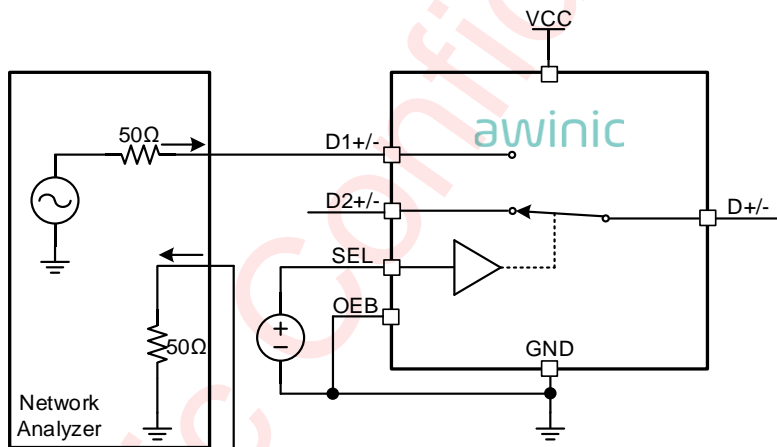

Figure 10 OFF Isolation

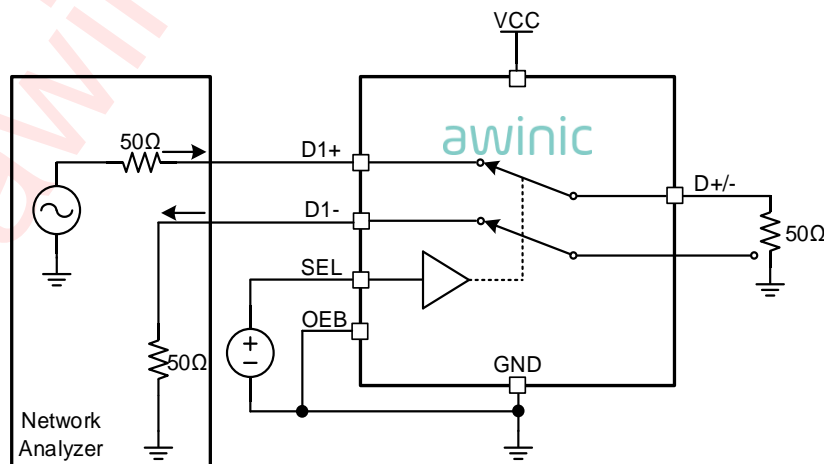

Figure 11 Cross Talk

Detailed Functional Description

The AW35743G is a Hi-Speed USB 2.0 DPDT switch with integrated protection for USB D+ and D-, it can be configured as a dual 1:2 or 2:1 switch. The AW35743G will protect D+ and D- pins when stressed with voltages up to 24V. The device can pass signals with bandwidth 1GHz to maintain signal integrity and eye compliance.

Over-Voltage Protection

AW35743G is designed to protect the system from damage. Over-voltage event happens when voltage on D+/D- exceeds 3.83V(typ.), and device will activate OVP to disconnect the switches, the FLTB will also be pulled low to indicate there is OV event to the system.

Reverse-Blocking Switches

The switches in the AW35743G are reverse-blocking, using back-to-back MOSFET switches in each path. When the switches are OFF, current is blocked in both directions from D1+, D2+ or D1-, D2- to D+ or D-. This provides more system flexibility for USB transceivers or other I/O devices connected in the system.

High Impedance Mode

When OEB is logic high, the AW35743G is in high impedance mode, all the signal paths are in Hi-Z state.

OEB	SEL1	SEL2	D- Connection	D+ Connection
H	X	X	High-Z	High-Z
L	L	L	D- to D1-	D+ to D1+
L	L	H	D- to D1-	D+ to D2+
L	H	L	D- to D2-	D+ to D1+
L	H	H	D- to D2-	D+ to D2+

PCB Layout Consideration

To obtain the optimal performance of AW35743G, PCB layout should be considered carefully. Here are some

guidelines:

1. Place supply bypass capacitors as close to VCC pin as possible and avoid placing the bypass capacitors near the D+/D- traces.
2. The differential characteristic impedance of D+ and D- traces is suggested to be 90Ω , and it's better to shield D+ and D- traces by ground planes.
3. Route the high-speed USB signals using a minimum of vias and corners which reduces signal reflections and impedance changes.
4. Do not route USB traces under or near crystals, oscillators, clock signal generators, switching regulators, mounting holes, magnetic devices or ICs that use or duplicate clock signals.
5. Avoid stubs on the high-speed USB signals because they cause signal reflections.
6. Route all high-speed USB signal traces over continuous GND planes, with no interruptions.

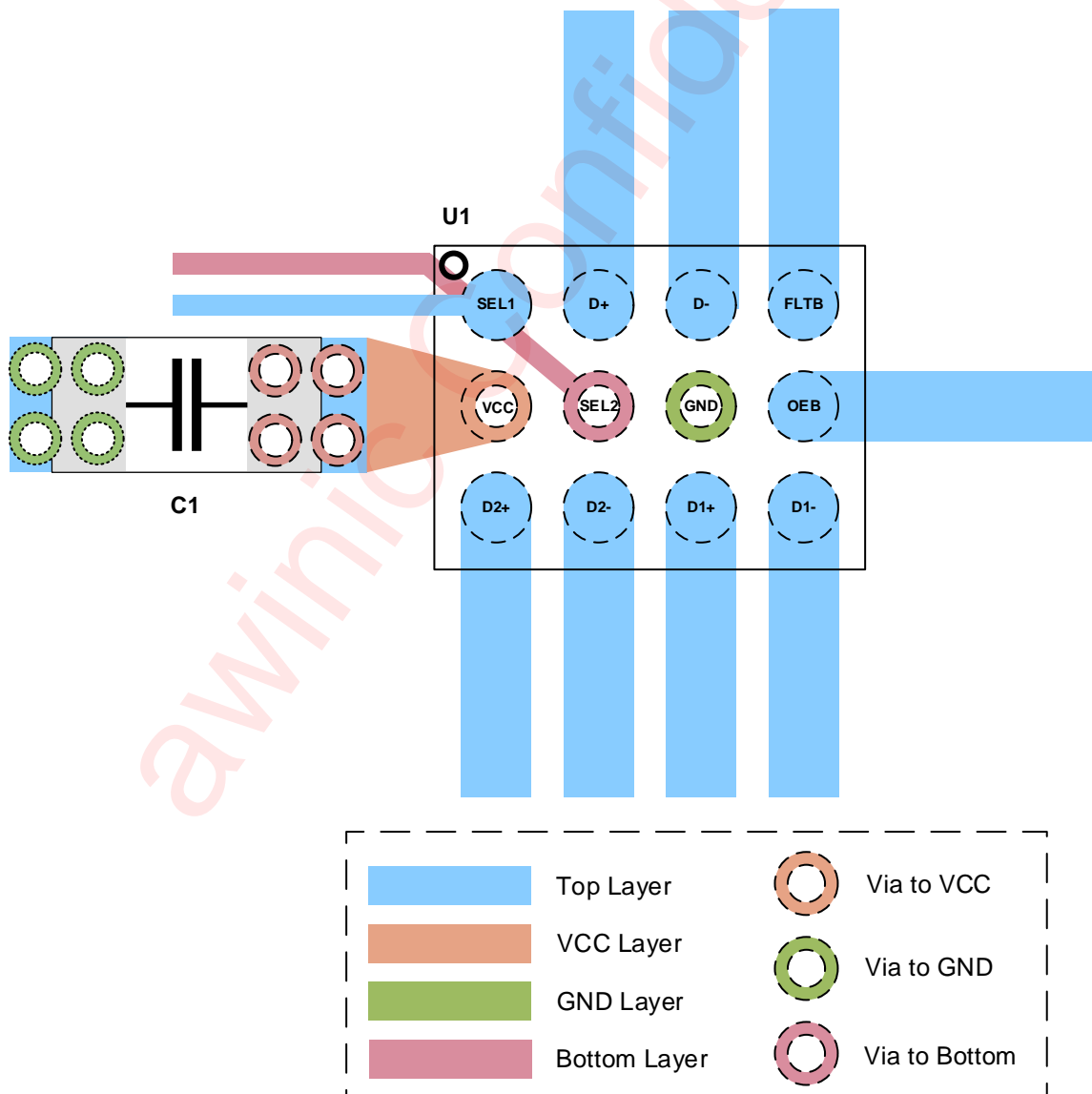

Tape And Reel Information

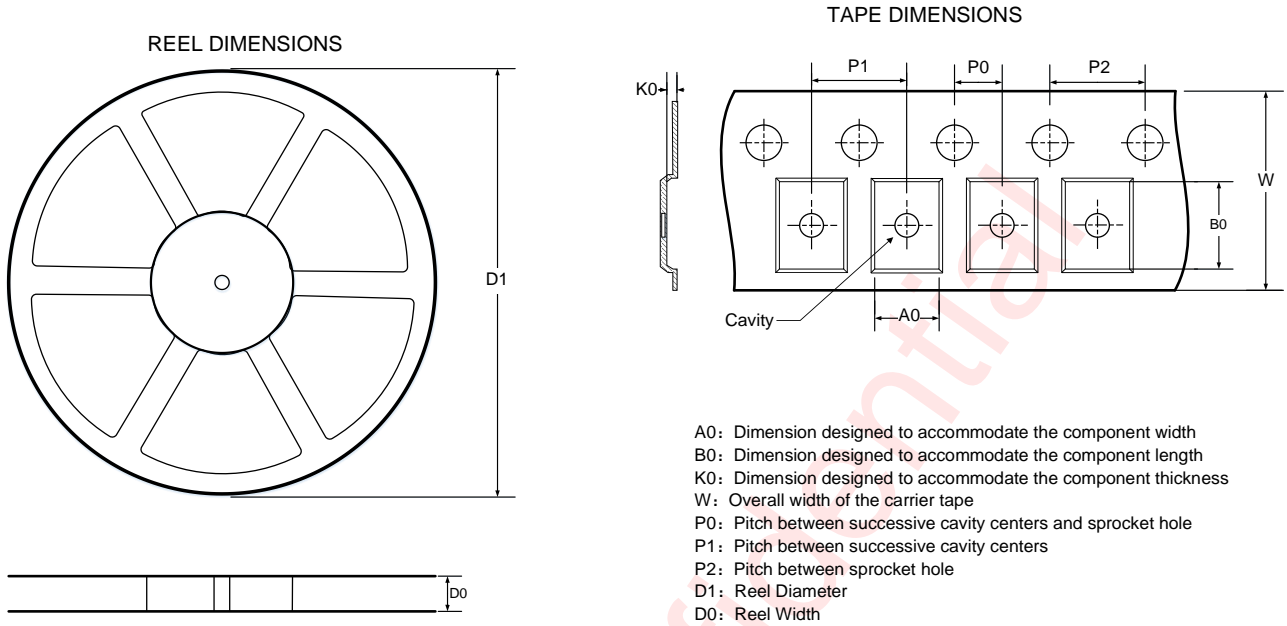

QUADRANT ASSIGNMENTS FOR PIN 1 ORIENTATION IN TAPE

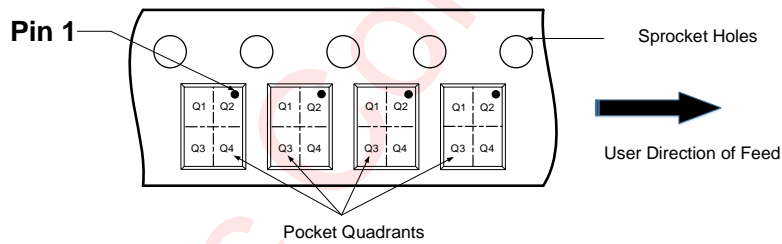

Note: The above picture is for reference only. Please refer to the value in the table below for the actual size

DIMENSIONS AND PIN1 ORIENTATION

D1 (mm)	D0 (mm)	A0 (mm)	B0 (mm)	K0 (mm)	P0 (mm)	P1 (mm)	P2 (mm)	W (mm)	Pin1 Quadrant
178.00	9.50	1.30	1.70	0.75	2.00	4.00	4.00	8.00	Q2

All dimensions are nominal

Package Description

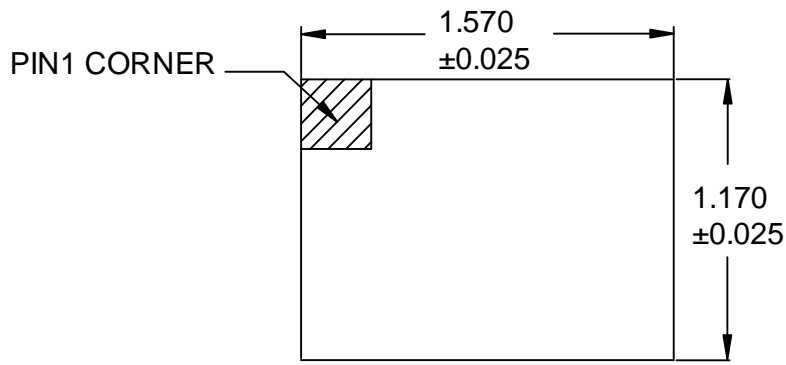

Top View

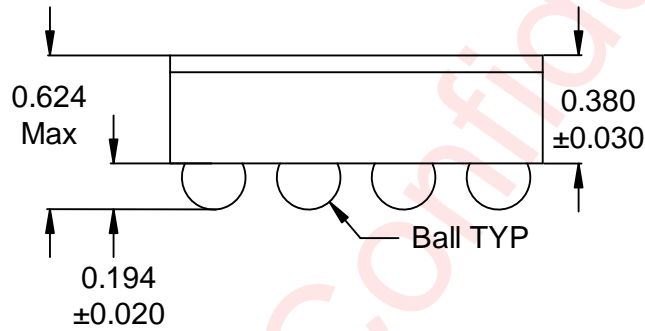

Side View

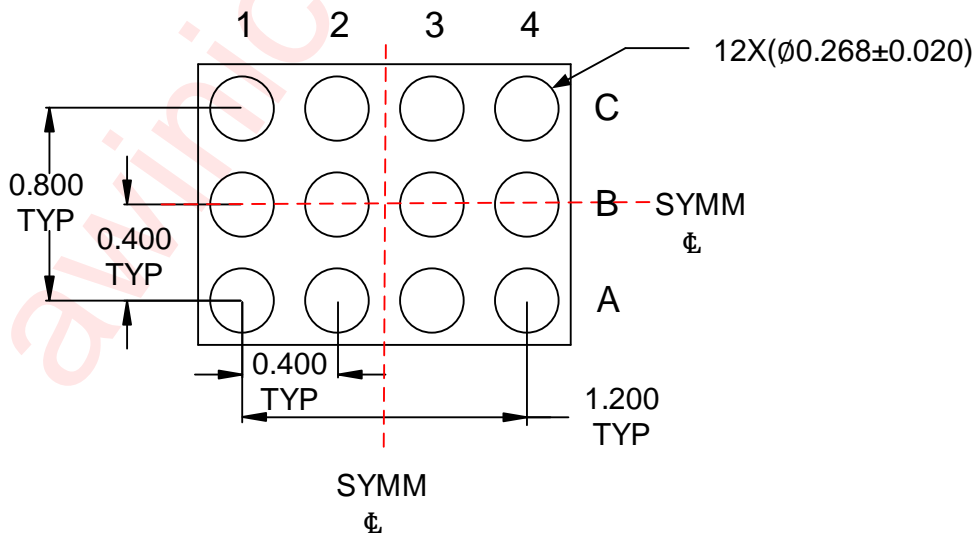

Bottom View

Unit: mm

Land Pattern Data

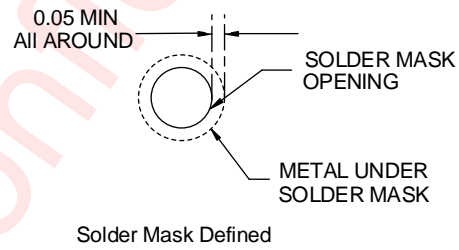
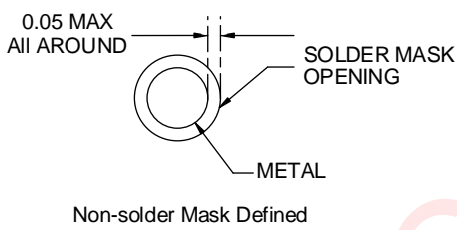
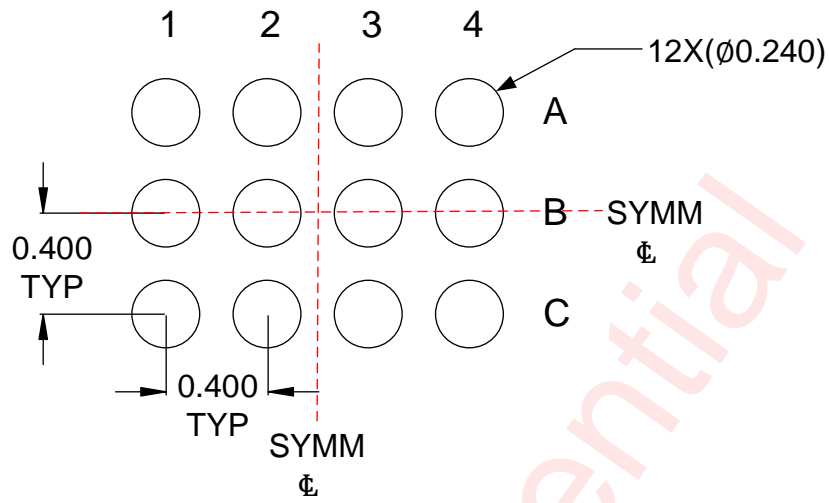

Unit: mm

Revision History

Version	Date	Change Record
V1.0	Aug. 2023	Officially released
V1.1	Nov.2023	Added the description of the reverse-blocking(P11)

awinic Confidential

Disclaimer

Information in this document is believed to be accurate and reliable. However, Shanghai AWINIC Technology Co., Ltd (AWINIC Technology) does not give any representations or warranties, expressed or implied, as to the accuracy or completeness of such information and shall have no liability for the consequences of use of such information.

AWINIC Technology reserves the right to make changes to information published in this document, including without limitation specifications and product descriptions, at any time and without notice. Customers shall obtain the latest relevant information before placing orders and shall verify that such information is current and complete. This document supersedes and replaces all information supplied prior to the publication hereof.

AWINIC Technology products are not designed, authorized or warranted to be suitable for use in medical, military, aircraft, space or life support equipment, nor in applications where failure or malfunction of an AWINIC Technology product can reasonably be expected to result in personal injury, death or severe property or environmental damage. AWINIC Technology accepts no liability for inclusion and/or use of AWINIC Technology products in such equipment or applications and therefore such inclusion and/or use is at the customer's own risk.

Applications that are described herein for any of these products are for illustrative purposes only. AWINIC Technology makes no representation or warranty that such applications will be suitable for the specified use without further testing or modification.

All products are sold subject to the general terms and conditions of commercial sale supplied at the time of order acknowledgement.

Nothing in this document may be interpreted or construed as an offer to sell products that is open for acceptance or the grant, conveyance or implication of any license under any copyrights, patents or other industrial or intellectual property rights.

Reproduction of AWINIC information in AWINIC data books or data sheets is permissible only if reproduction is without alteration and is accompanied by all associated warranties, conditions, limitations, and notices. AWINIC is not responsible or liable for such altered documentation. Information of third parties may be subject to additional restrictions.

Resale of AWINIC components or services with statements different from or beyond the parameters stated by AWINIC for that component or service voids all express and any implied warranties for the associated AWINIC component or service and is an unfair and deceptive business practice. AWINIC is not responsible or liable for any such statements.