

300 mA High Performance Low-Dropout Linear Regulator

Features

- Input voltage range: 1.4V to 5.5V
- Fixed outputs of 1.2V, 1.8V, 2.8V, 3.0V, 3.3V
- Rated output current: 300mA
- Quiescent current: typical 50 μ A
- Typical 0.1 μ A shutdown current
- Very low inrush current
- Typical 184mV dropout voltage (I_{OUT}=300mA, 2.8V output)
- Power supply rejection ratio: typical 85dB (I_{OUT}=30mA, freq=1kHz, 2.8V output)
- Noise: typical 42 μ Vrms (I_{OUT}=30mA, BW=10Hz to 100kHz, 2.8V output)
- Built-in output short protection: typical 120mA when output short to ground
- FOWLP 0.645mmX0.645mm-4B package

Applications

Battery-powered equipment
Smart phone
Digital camera
STB

Typical Application Circuit

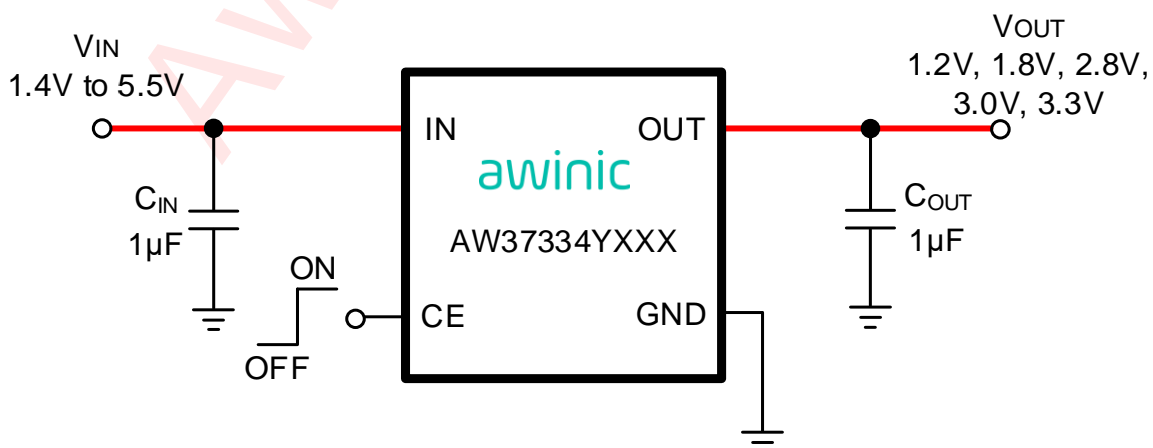

General Description

AW37334YXXX is a low dropout voltage regulator featuring low ON resistance, high PSRR, low Noise, good load/line transient response and smooth soft-start.

AW37334YXXX integrates current limit, short circuit protection, thermal shutdown, sufficiently protecting IC from being damaged.

AW37334YXXX is designed to work with a 1 μ F or more input ceramic capacitor and a 1 μ F or more output ceramic capacitor. The low power dissipation and good dynamic response make AW37334YXXX very suitable for hand-held communication equipment. Tiny package makes high density mounting of the IC on boards possible.

Pin Configuration And Top Mark

AW37334YXXXFOR
(Top View)

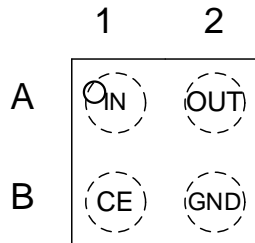

AW37334YXXXFOR Marking
(Top View)

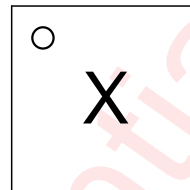

X-Production Tracing Code

Pin Definition

No.	NAME	DESCRIPTION
A1	IN	Input supply pin. Put a 1 μ F or more bypass capacitor at the power supply.
A2	OUT	Regulated output voltage pin. Put a 1 μ F or more ceramic capacitor at the output pin.
B1	CE	Chip enable pin. Built-in 140nA pull-down current. (High Active)
B2	GND	Ground.

Name Rule

AW37 334 Y XXX ZZZ

Package

FOR: FOWLP 0.645mm X0.645mm-4B

Output Voltage

E.g.
280: Output Voltage 2.8V

Auto-discharge Function

D: Available
B: Not available

Rated Current

334: Rated Current 300mA

Functional Block Diagram

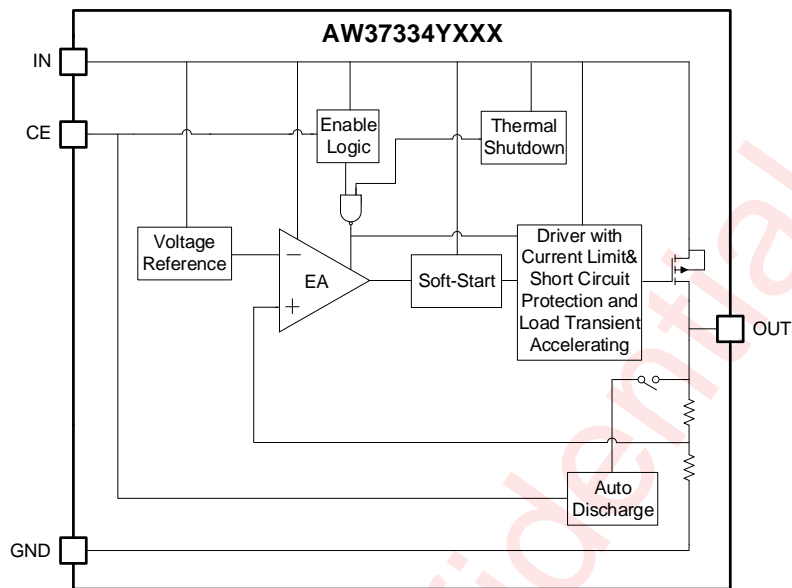

Typical Application Circuits

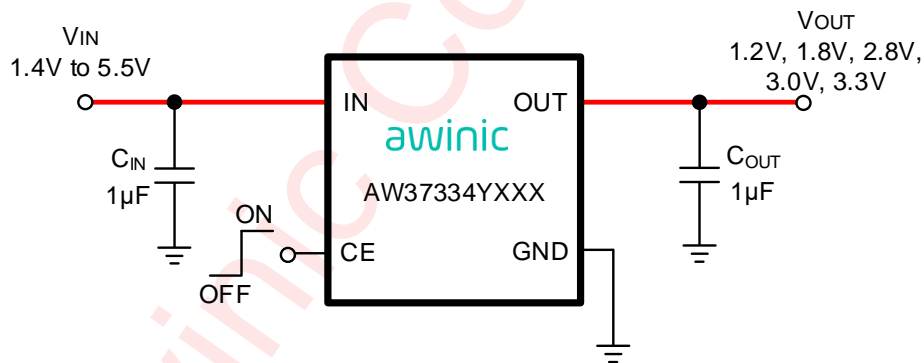

AW37334YXXX Application Circuit

Notice for typical application circuits:

Capacitance of C_{IN} and C_{OUT} should be $1\mu\text{F}$ or more.

Ordering Information

Part Number	Temperature	Package	Moisture Sensitivity Level	Environmental Information	Delivery Form
AW37334D120FOR	-40°C~85°C	FOWLP 0.645X0.645-4B	MSL1	ROHS+HF	3000 units/ Tape and Reel
AW37334D180FOR	-40°C~85°C	FOWLP 0.645X0.645-4B	MSL1	ROHS+HF	3000 units/ Tape and Reel
AW37334D280FOR	-40°C~85°C	FOWLP 0.645X0.645-4B	MSL1	ROHS+HF	3000 units/ Tape and Reel

Absolute Maximum Ratings^(NOTE1)

PARAMETERS		RANGE
Input voltage range		-0.3V to 6.5V
Enable control voltage range		-0.3V to 6.5V
Output voltage range		-0.3V to VIN+0.3V, max. 6.5V
Maximum operating junction temperature T _{J_MAX}		150°C
Recommended operating junction temperature T _{J_REC}		-40°C to 125°C
Operating free-air temperature range		-40°C to 85°C
Storage temperature T _{STG}		-65°C to 150°C
Lead temperature (soldering 10 seconds)		260°C
Junction-to-ambient thermal resistance R _{θJA} ^(NOTE2)		172.9°C/W
Maximum power consumption T _A =25°C, T _{J_REC} =125°C		723mW
ESD	HBM (Human body model) ^(NOTE3)	±2kV
	CDM(Charged device model) ^(NOTE4)	±1.5kV
Latch-Up ^(NOTE5)		+IT: 200mA - IT: -200mA

NOTE1: Conditions out of those ranges listed in "absolute maximum ratings" may cause permanent damages to the device. In spite of the limits above, functional operation conditions of the device should within the ranges listed in "recommended operating conditions". Exposure to absolute-maximum-rated conditions for prolonged periods may affect device reliability.

NOTE2: Thermal resistances follow JEDEC 2S2P standards, and is usually highly dependent on PCB layout.

NOTE3: All pins. Test Condition: ESDA/JEDEC JS-001-2017.

NOTE4: All pins. Test Condition: ESDA/JEDEC JS-002-2018.

NOTE5: Test Condition: JESD78E.

Electrical Characteristics

$V_{IN}=V_{OUT(SET)}+1V$, $V_{CE}>1V$, $I_{OUT}=1mA$, $C_{IN}=C_{OUT}=1\mu F$, $T_A=25^\circ C$ (unless otherwise noted)

PARAMETER		TEST CONDITION	MIN	TYP	MAX	UNIT
V_{IN}	Input Voltage Range		1.4		5.5	V
V_{OUT_ACC}	Output Voltage Accuracy	$T_A=25^\circ C$	-1		1	%
		$-40^\circ C \leq T_A \leq 85^\circ C^{(1)}$	-2		2	
$LOAD_{Reg}$	Load Regulation	$1mA \leq I_{OUT} \leq 300mA$		1		mV
$LINE_{Reg}$	Line Regulation	$V_{OUT(SET)}+0.5V \leq V_{IN} \leq 5.5V$		1		mV
$V_{dropout}$	Dropout Voltage	$I_{OUT}=300mA$, When V_{OUT} falls 100mV below $V_{OUT(SET)}$	$V_{OUT(SET)}=1.2V$		576	mV
			$V_{OUT(SET)}=1.8V$		310	
			$V_{OUT(SET)}=2.8V$		184	
I_{SD}	Shutdown Current	$V_{CE}<0.4V$		0.1		μA
I_Q	Quiescent Current	$I_{OUT}=0mA$		50		μA
V_{CEH}	CE Input Voltage "H"	$-40^\circ C \leq T_A \leq 85^\circ C$	1			V
V_{CEL}	CE Input Voltage "L"	$-40^\circ C \leq T_A \leq 85^\circ C$			0.4	V
PSRR	Power Supply Ripple Rejection	$I_{OUT}=30mA$, $f=1kHz$ $V_{OUT(SET)}=2.8V$		85		dB
V_N	Output Voltage Noise	$I_{OUT}=30mA$ $BW=10Hz$ to $100kHz$	$V_{OUT(SET)}=1.2V$		23	μV_{rms}
			$V_{OUT(SET)}=1.8V$		33	
			$V_{OUT(SET)}=2.8V$		42	
I_{CL}	Output Current Limit	$V_{OUT}=90\% * V_{OUT(SET)}$	300			mA
I_{SC}	Short Current Limit	$V_{OUT}<10\% * V_{OUT(SET)}$		120		mA
VTC	Output Voltage Temperature Coefficient	$-40^\circ C \leq T_A \leq 85^\circ C$		± 40		ppm/ $^\circ C$
R_{DISC}	Auto Discharge Resistance	$V_{IN}=4V$, $V_{CE}<0.4V$, $V_{OUT}=2.8V$		130		Ω
I_{CE}	CE Pull Down Current			140		nA
T_{SDH}	Thermal Shutdown Threshold	Temperature Rising		160		$^\circ C$
T_{SDL}	Thermal Shutdown Reset Threshold	Temperature Falling		130		$^\circ C$

Note1: Minimum and/or maximum limit is guaranteed by design and by statistical analysis of device characterization data. The specification is not guaranteed by production testing.

Typical Characteristics

$V_{IN}=V_{OUT(SET)}+1V$, $V_{CE}>1V$, $I_{OUT}=1mA$, $C_{IN}=C_{OUT}=1\mu F$, $T_A=25^\circ C$, In Typical Application Circuit, unless otherwise noted.

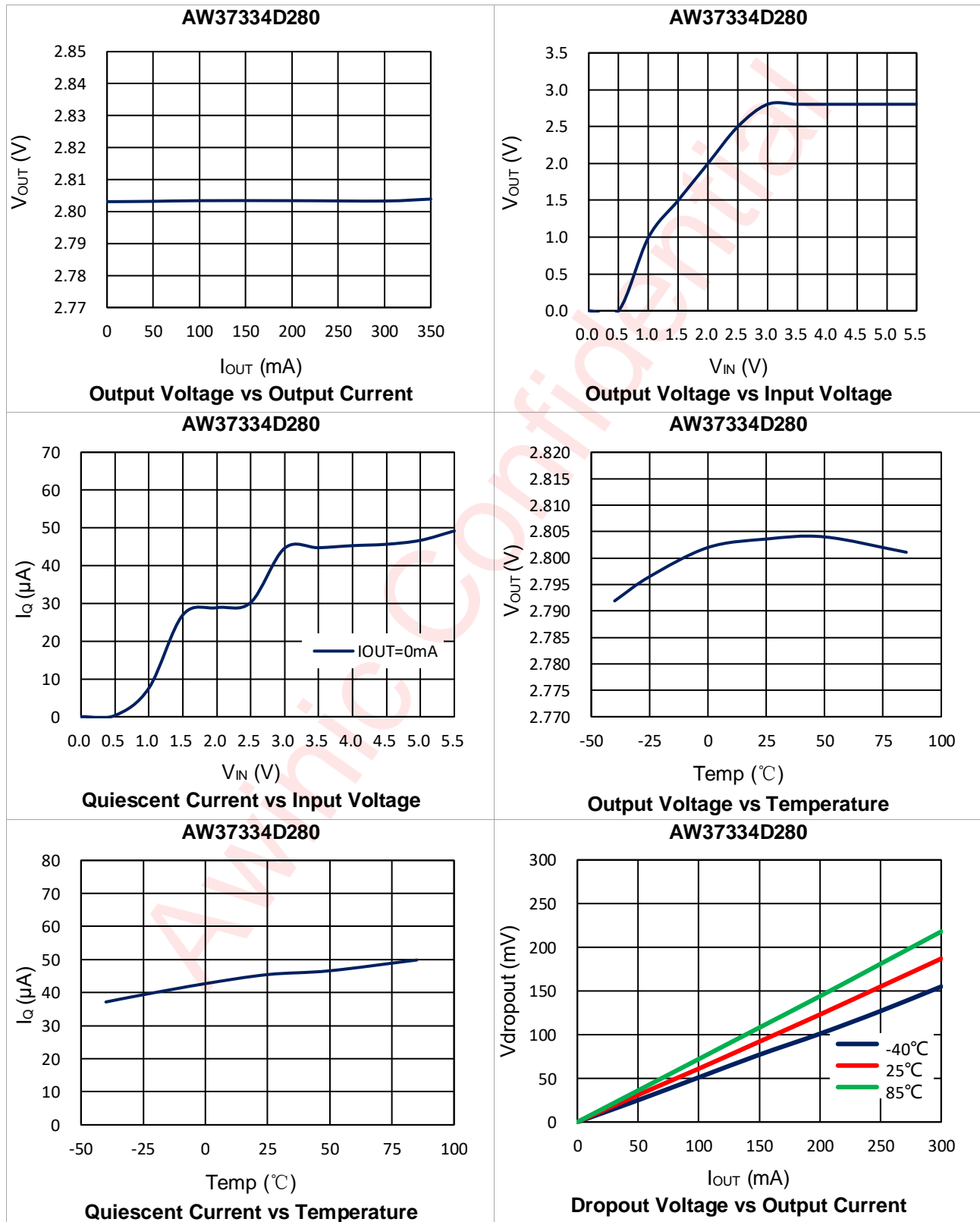

Typical Characteristics (Continued)

$V_{IN}=V_{OUT(SET)}+1V$, $V_{CE}>1V$, $I_{OUT}=1mA$, $C_{IN}=C_{OUT}=1\mu F$, $T_A=25^\circ C$, In Typical Application Circuit, unless otherwise noted.

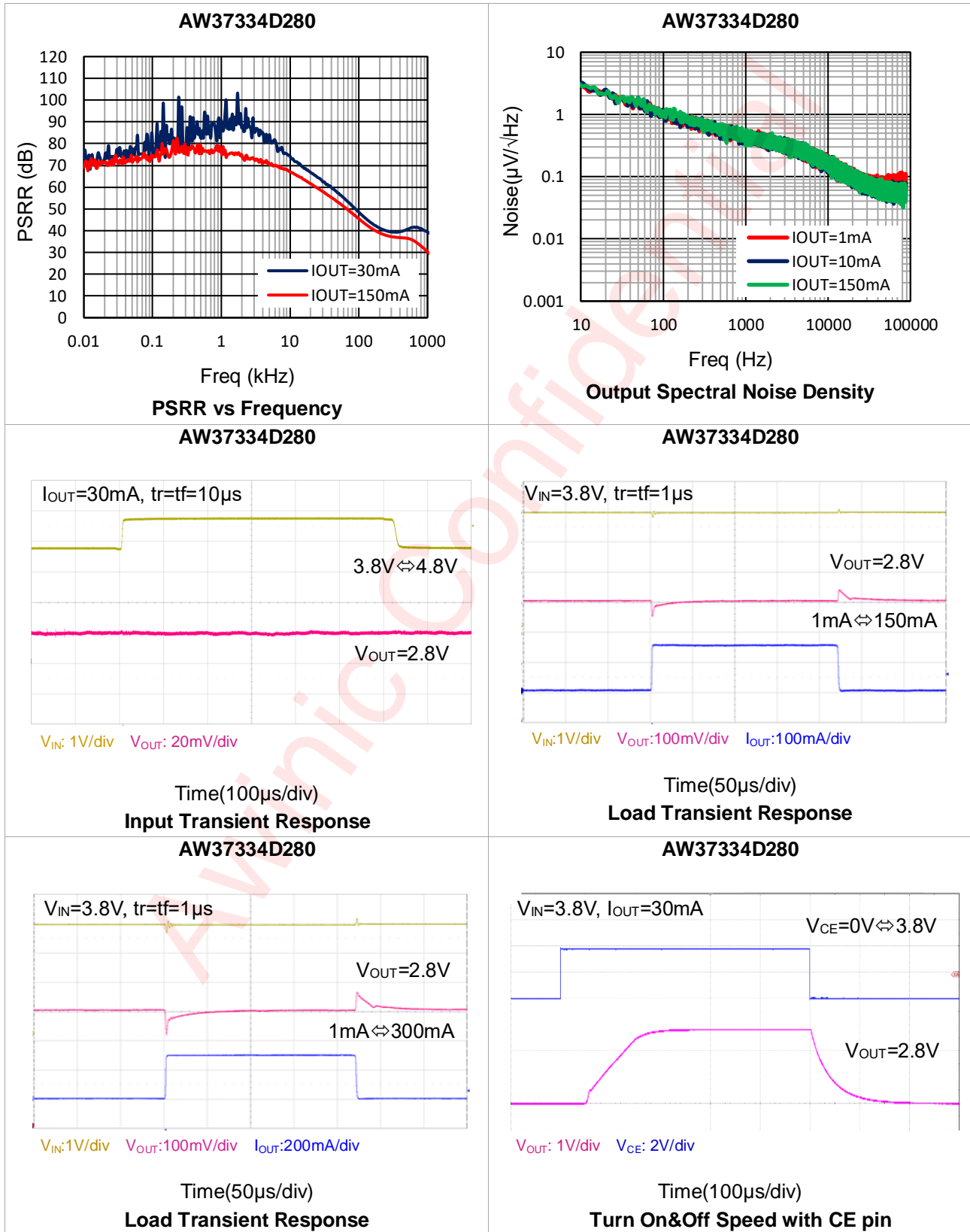

Detailed Functional Description

AW37334YXXX is a low dropout voltage regulator. After powered on, with CE pin assertion, feedback voltage signal from the integrated resistor network and a voltage related to the voltage reference are transmit to positive input terminal and negative input terminal of an error amplifier (EA) respectively. The output signal of EA is used to control the open-state of power MOSFET. After soft-start, feedback voltage signal compares with the established reference voltage, making output voltage stable and accurate. AW37334YXXX integrates function of load transient accelerating, making LDO obtain excellent dynamic load transient response performance.

Enable Operation

AW37334YXXX uses CE pin to realize enable operation. Applying proper value of voltage to CE pin can make IC enable/disable.

If the voltage of CE pin is less than 0.4V, AW37334YXXX is guaranteed to be disabled. In this state, function modules of IC and power MOSFET are turned off. And the auto discharge function is enabled making output discharge through an on-state NMOSFET to Ground. In disable state, AW37334YXXX only consumes a typical 10nA current.

If the voltage of CE pin is more than 1V, AW37334YXXX is guaranteed to be enabled. In this state, the auto discharge function is disabled, and AW37334YXXX regulates output voltage to the designed value of voltage. A 140nA pull down current to Ground is built-in at CE pin, making sure that the IC is disabled when CE pin floats. If Enable function is not required, CE pin should be connected directly to IN pin.

Output Current Limit

AW37334YXXX integrates output current limit function, protecting IC from excessive current.

When the load is excessively heavy, AW37334YXXX limits the current flowing through the IC to a typical 500mA current. This value is specially designed, so that IC is protected properly and the output capability of 300mA is not influenced either.

Meanwhile, AW37334YXXX integrates a 120mA fold-back current limit function, lowering the system dissipation when output overload or short to Ground.

Thermal Shutdown

AW37334YXXX integrates thermal shutdown function, protect IC from excessively high temperature.

When the chip temperature exceeds 160°C, AW37334YXXX detects it as an over-temperature event, triggering thermal shutdown, which will turn off the main function module, including power MOSFET. This inhibits increase of chip's temperature. IC would keep the protection-state on until the chip's temperature falls below to 130°C. At this moment, the over-temperature protection-state is released, IC resumes to work again. The hysteresis avoids IC's turning off and on frequently around the the Thermal Shutdown threshold.

Auto Discharge

AW37334YXXX makes output voltage discharge quickly when in CE disable state or thermal shutdown state, benefit from integrating auto discharge function. Auto discharge function is implemented by integrated a NMOSFET of typical 130Ω R_{dson} route from Output to Ground, and the route is get through in CE disable state or thermal shutdown state. This feature prevents residual charge voltage on the output capacitor, which may impact proper power up of the system connected to the converter. It should be noted that auto discharge function is optional according to different specs.

Application Information

Power Dissipation and Device Operation

The permissible power dissipation is dependent on the ambient temperature T_A and the junction-to-ambient thermal resistance $R_{\theta JA}$.

The absolute maximum allowable power dissipation for the device in a given package can be calculated using Equation below, where $T_{J_MAX} = 150^\circ\text{C}$:

$$PD_{MAX_ABS} = (T_{J_MAX} - T_A) / R_{\theta JA}$$

The recommended maximum allowable power dissipation for the device in a given package can be calculated using Equation below, where $T_{J_REC} = 125^\circ\text{C}$:

$$PD_{MAX_REC} = (T_{J_REC} - T_A) / R_{\theta JA}$$

The actual power being dissipated in the device can be represented by Equation below:

$$PD_{ACT} = (V_{IN} - V_{OUT}) \times I_{OUT}$$

These equations above establish the relationship between the maximum power dissipation allowed due to thermal consideration, the voltage drop across the device, and the continuous current capability of the device.

The graphs of Power Dissipation vs. Ambient Temperature are showed below :

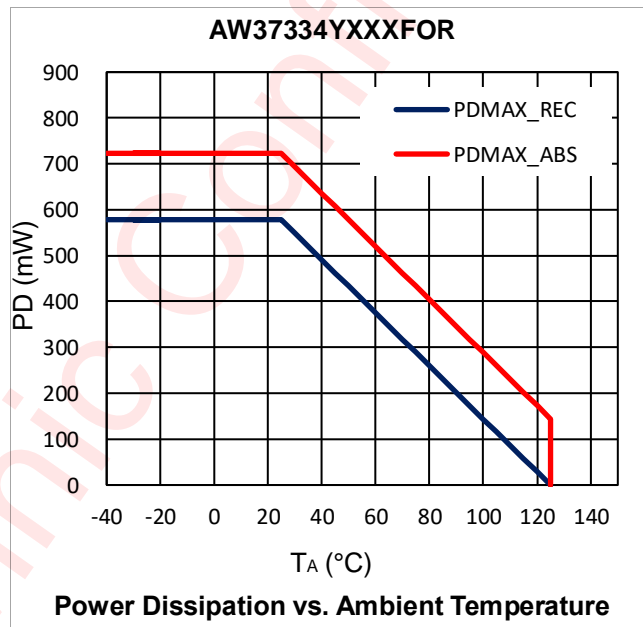

The above graphs show the maximum power dissipation of the respective package at $T_{J_REC} = 125^\circ\text{C}$ and $T_{J_MAX} = 150^\circ\text{C}$. Operating the device in the region between PD_{MAX_REC} and PD_{MAX_ABS} might have a negative influence on its lifetime.

Capacitors Selection

IN pin: Input Capacitor C_{IN}

AW37334YXXX advises to use a $1\mu\text{F}$ or more X5R or X7R ceramic capacitor at IN pin as shown in Typical Application Circuit.

OUT pin: Output Capacitor C_{OUT}

AW37334YXXX advises to use a $1\mu\text{F}$ or more X5R or X7R ceramic capacitor at OUT pin as shown in Typical Application Circuit.

Recommended Components List

Component	PART No.	DESCRIPTION	MFR	TYP.	UNIT
C _{IN}	GRM155R61A105KE15	10V, X5R, 0402	MURATA	1	μF
C _{OUT}	GRM155R61A105KE15	10V, X5R, 0402	MURATA	1	μF

PCB Layout Consideration

The performance of a power source circuit using this device is highly dependent on a peripheral circuit. To obtain the optimal performance, a peripheral component or the device mounted on PCB should not exceed its rated voltage, rated current or rated power. When designing a peripheral circuit, guidelines below for PCB layout of AW37334YXXX should be obeyed:

1. All peripheral components should be placed as close to the chip as possible. C_{IN} and C_{OUT} should be close to IN and OUT pins respectively. Avoid connecting device and chip pins with two different layers of copper, use the same layer of copper instead.
2. IN and OUT pin are the large current input and output of the chip, make IN, OUT, and meanwhile GND lines sufficient.
3. The connection lines between the planes of C_{IN} or C_{OUT} and respective chip pin should be as short and wide as possible, to reduce noise and EMI interference, or it may cause noise pickup or unstable operation.
4. The exposed plane of chip and GND pins must be connected to the large-area ground layer of PCB directly, meanwhile place sufficient vias below the exposed plane. Thus we can decrease the thermal resistor on the board to optimize heat-diffusion performance.

Tape And Reel Information

FOWLP 0.645mm×0.645mm-4B

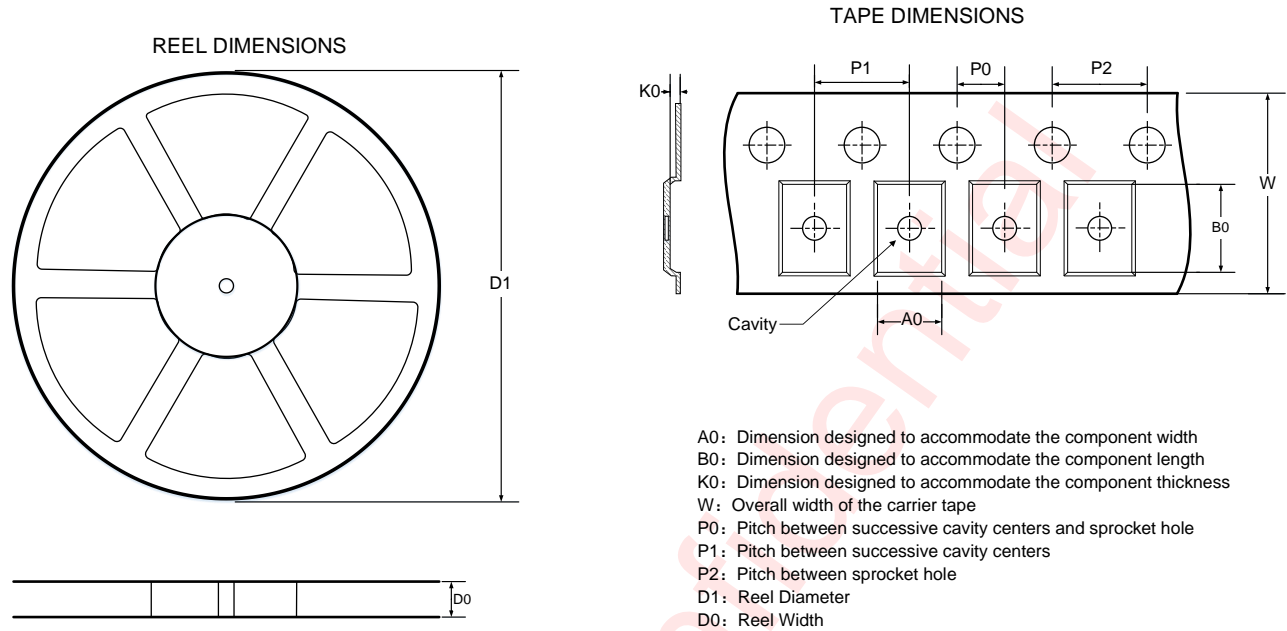

QUADRANT ASSIGNMENTS FOR PIN 1 ORIENTATION IN TAPE

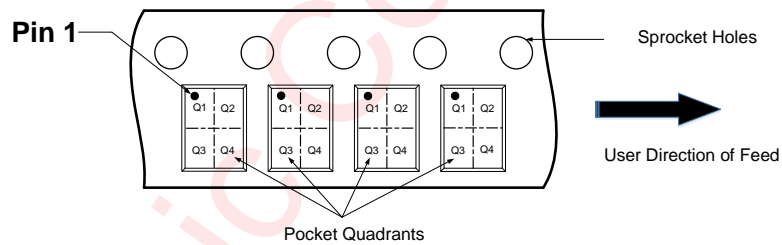

Note: The above picture is for reference only. Please refer to the value in the table below for the actual size

DIMENSIONS AND PIN1 ORIENTATION

D1 (mm)	D0 (mm)	A0 (mm)	B0 (mm)	K0 (mm)	P0 (mm)	P1 (mm)	P2 (mm)	W (mm)	Pin1 Quadrant
179.00	9.00	0.71	0.71	0.37	2.00	4.00	4.00	8.00	Q1

All dimensions are nominal

Package Description

FOWLP 0.645mm×0.645mm-4B

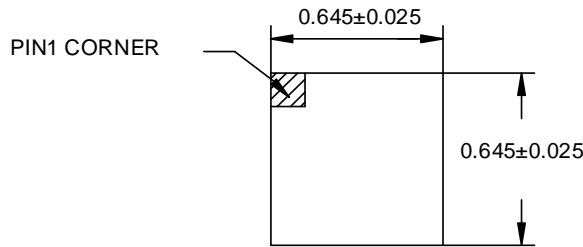

Top View

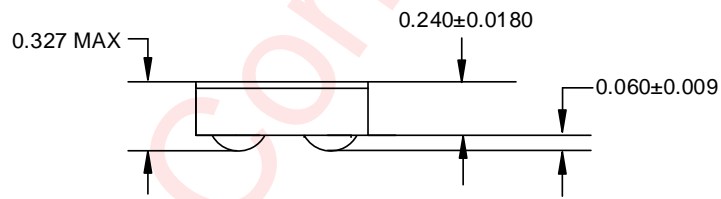

Side View

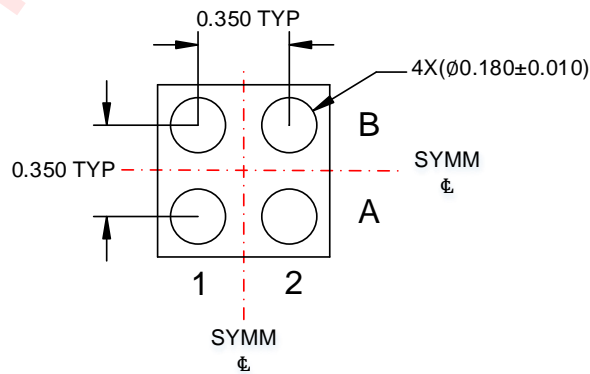

Bottom View

Unit: mm

Land Pattern Data

FOWLP 0.645mm×0.645mm-4B

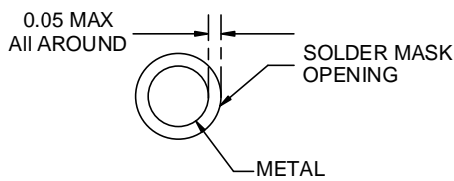
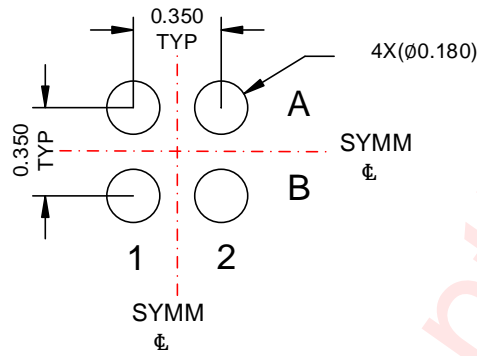

NON-SOLDER MASK DEFINED

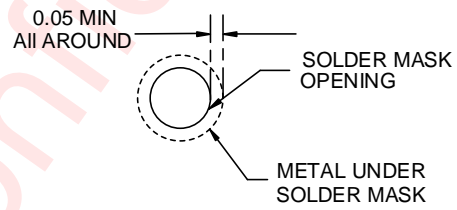

SOLDER MASK DEFINED

Unit: mm

Revision History

Version	Date	Change Record
V1.0	Feb. 2025	Officially released
V1.1	Dec. 2025	Add 1.2V and 1.8V edition.(P4-5)

Awinic Confidential

Disclaimer

All trademarks are the property of their respective owners. Information in this document is believed to be accurate and reliable. However, Shanghai AWINIC Technology Co., Ltd (AWINIC Technology) does not give any representations or warranties, expressed or implied, as to the accuracy or completeness of such information and shall have no liability for the consequences of use of such information.

AWINIC Technology reserves the right to make changes to information published in this document, including without limitation specifications and product descriptions, at any time and without notice. Customers shall obtain the latest relevant information before placing orders and shall verify that such information is current and complete. This document supersedes and replaces all information supplied prior to the publication hereof.

AWINIC Technology products are not designed, authorized or warranted to be suitable for use in medical, military, aircraft, space or life support equipment, nor in applications where failure or malfunction of an AWINIC Technology product can reasonably be expected to result in personal injury, death or severe property or environmental damage. AWINIC Technology accepts no liability for inclusion and/or use of AWINIC Technology products in such equipment or applications and therefore such inclusion and/or use is at the customer's own risk.

Applications that are described herein for any of these products are for illustrative purposes only. AWINIC Technology makes no representation or warranty that such applications will be suitable for the specified use without further testing or modification.

All products are sold subject to the general terms and conditions of commercial sale supplied at the time of order acknowledgement.

Nothing in this document may be interpreted or construed as an offer to sell products that is open for acceptance or the grant, conveyance or implication of any license under any copyrights, patents or other industrial or intellectual property rights.

Reproduction of AWINIC information in AWINIC data books or data sheets is permissible only if reproduction is without alteration and is accompanied by all associated warranties, conditions, limitations, and notices. AWINIC is not responsible or liable for such altered documentation. Information of third parties may be subject to additional restrictions.

Resale of AWINIC components or services with statements different from or beyond the parameters stated by AWINIC for that component or service voids all express and any implied warranties for the associated AWINIC component or service and is an unfair and deceptive business practice. AWINIC is not responsible or liable for any such statements.