

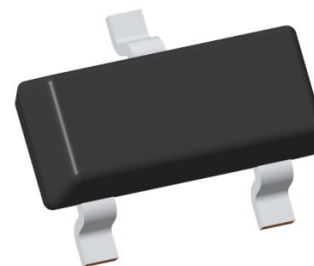

General Description

V(BR)DSS	RDSON MAX	ID Max.
-30V	88m Ω @-10V	-2.7A
	138m Ω @-4.5V	



Features

- Lead free product is acquired
- Surface mount package
- Moisture Sensitivity Level 3

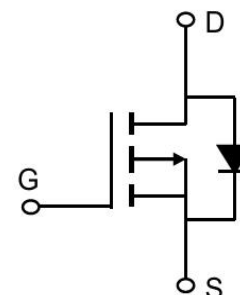

Mechanical Data

- SOT-23 Small Outline Plastic Package.
- Epoxy UL: 94V-0.
- Mounting Position: Any.



Package Marking and Ordering Information

Product ID	Pack	Marking	Qty(PCS)
2307	SOT-23	S7	3000

Absolute Maximum Ratings (Ta=25°C unless otherwise noted)

Parameter	Symbols	Value	Units
Drain-Source Voltage	VDS	-30	V
Gate-Source Voltage	VGS	±20	V
Continuous Drain Current	ID	-2.7	A
Continuous Source-Drain Current	IS	-0.91	
Power Dissipation (Note1)	PD	1.1	W
Junction Temperature	Tj	-55-+150	°C
Storage Temperature	Tstg	-55-+150	°C
Thermal Resistance From Junction to Ambient (Note1)	RθJA	114	°C/W

Electrical Characteristics (Ta=25°C, unless otherwise noted)

Parameter	Symbol	Test Conditions	Min.	Typ.	Max.	Unit
Off Characteristics						
Drain-Source Breakdown Voltage	V(BR)DSS	VGS=0V, ID=-250uA	-30			V
Gate-body Leakage	IGSS	VDS=0V, VGS=±20V			±100	nA
Zero Gate Voltage Drain current	IDSS	VDS=-30V, VGS=0V			-1	uA
		VDS=-30V, VGS=0V, Tj=55°C			-10	
On Characteristics						
Gate-Threshold voltage	VGS(th)	VDS=VGS, ID=-250uA	-1		-3	V
Drain-Source On-Resistance (Note2)	RDS(ON)	VGS=-4.5V, ID=-2.5A		110	138	mΩ
		VGS=-10V, ID=-3.5A		73	88	
Body diode voltage	VSD	IS=-0.75A, VGS=0V		-0.8	-1.2	V
Forward Transconductance (Note2)	gfs	VDS =-10V, ID =-3.5A		7		S
Dynamic (Note3)						
Input capacitance	Ciss	VDS=-15V, VGS=0V, f=1MHz		340		pF
Output capacitance	Coss			67		
Reverse Transfer capacitance	Crss			51		
Total gate charge	Qg	VGS=-4.5V, VDS=-15V, ID=-2.5A		4.1	6.2	nC
Gate-source charge	Qgs			1.3		
Gate-drain charge	Qgd			1.8		
Gate Resistance	Rg	f=1MHz		10		Ω
Turn-on Time	td(on)	VDD=-15V, RL=15Ω , ID=-1A, VGEN=-4.5V, Rg=1Ω		40	60	ns
Rise time	tr			40	60	
Turn-off Time	td(off)			20	40	
Fall time	tf			17	30	

Notes :

1. Surface mounted on 1" × 1" FR4 board.
2. Pulse Test : Pulse Width < 300μs, Duty Cycle ≤2%.
3. Guaranteed by design, not subject to production testing.



Typical Characteristics

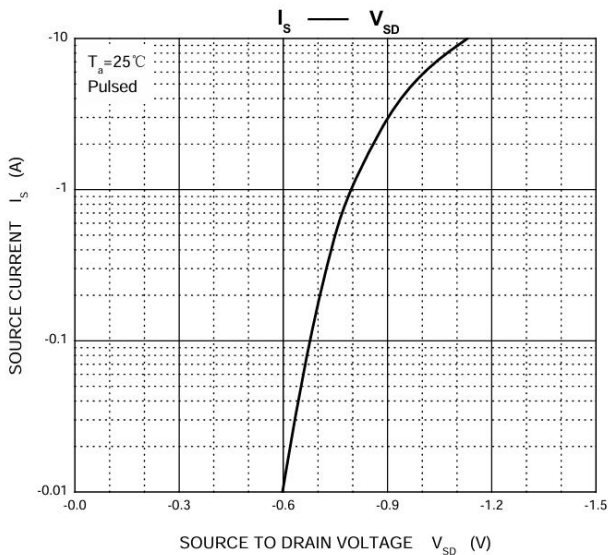
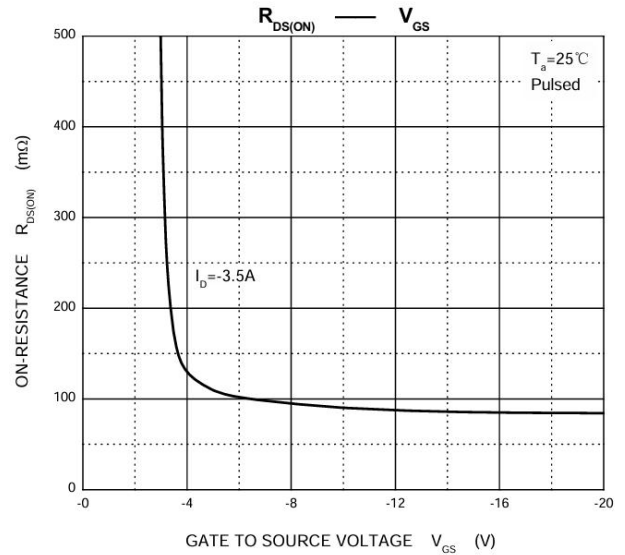
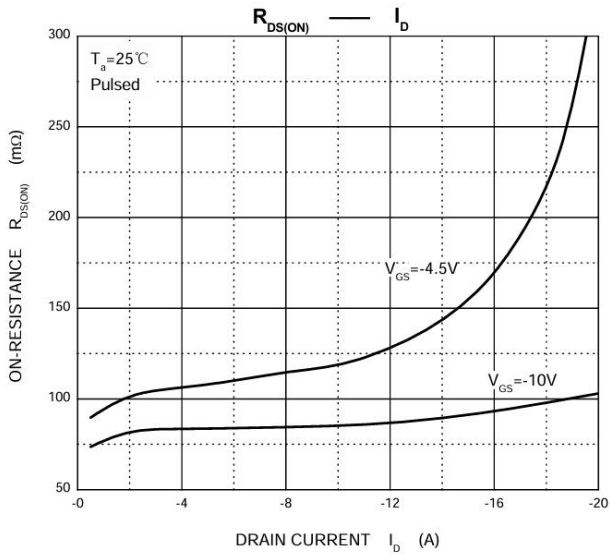
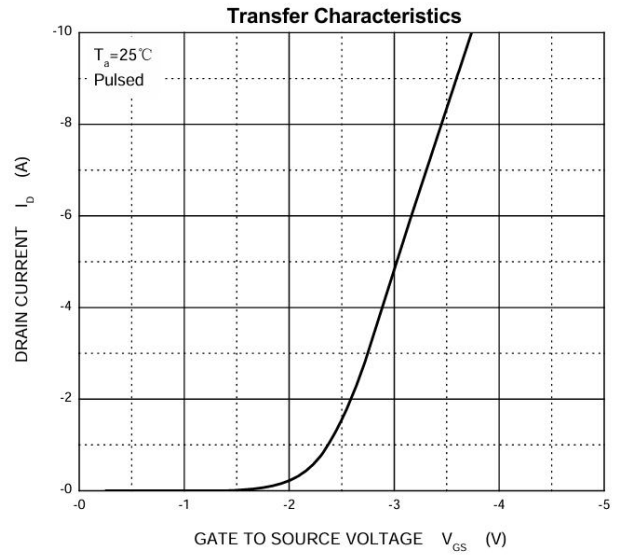
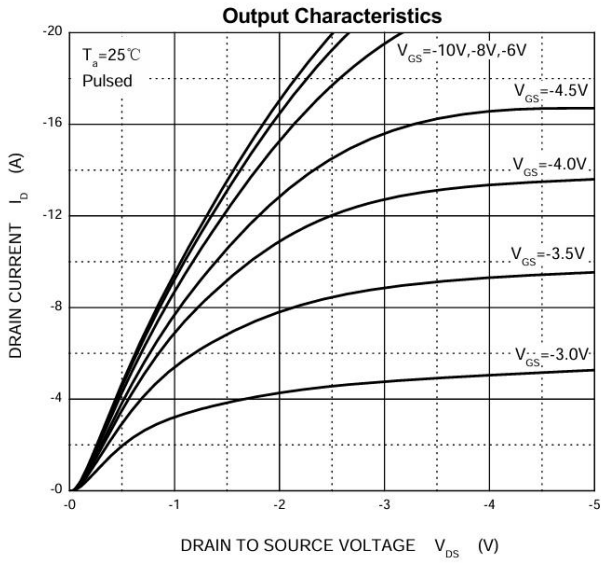

Package Information

Carrier Dimension(mm)

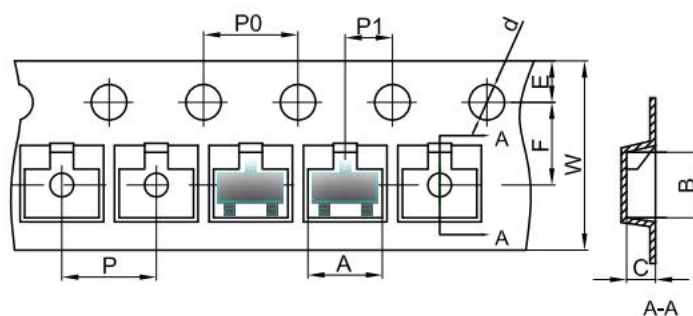

Dimensions are in millimeter

Pkg Type	A	B	C	d	E	F	P0	P	P1	10*P0	W
SOT-23	3.15	2.77	1.22	Ø1.50	1.75	3.50	4.00	4.00	2.00	40.00	8.00
(Tolerance)	±0.1	±0.1	±0.1	±0.1	±0.1	±0.1	±0.1	±0.1	±0.1	±0.2	±0.1

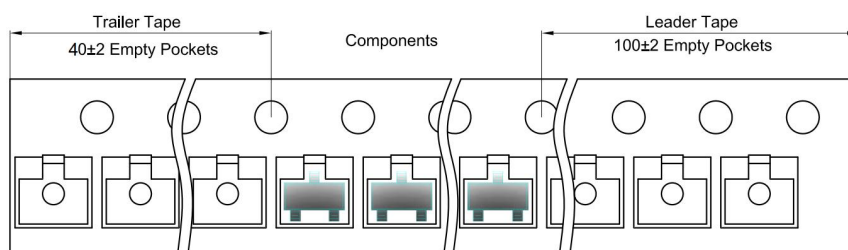

Reel Dimension(mm)

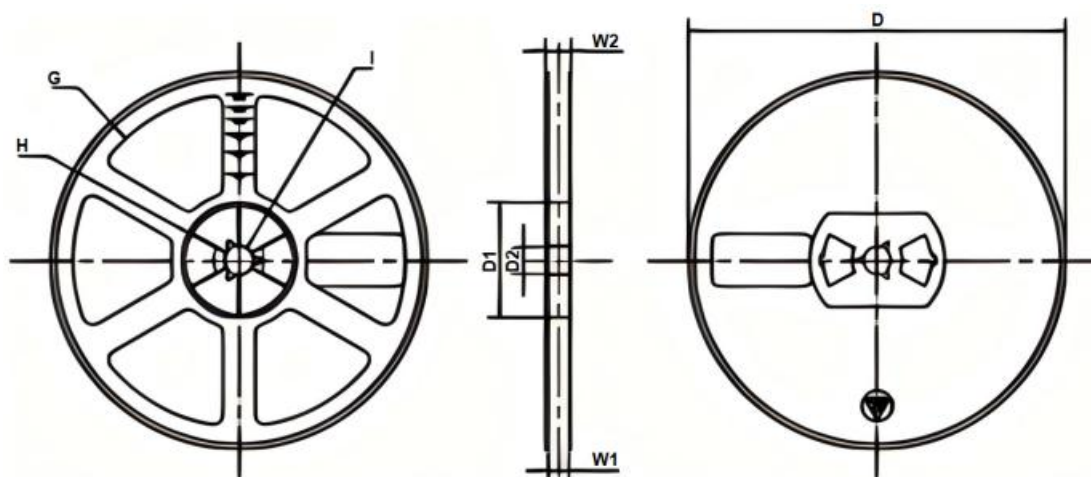

Reel Option	D	D1	D2	G	H	I	W1	W2
7" Dia	Φ178.00	54.40	13.00	R78.00	R25.60	R6.50	9.50	12.30
Tolerance	±2	±1	±1	±1	±1	±1	±1	±1

Package Specifications

Package	Reel Size	Reel DIA. (mm)	Q'TY/Reel (Kpcs)	Box Size (mm)	QTY/Box (Kpcs)	Carton Size (mm)	Q'TY/Carton (Kpcs)
SOT23	7'	178	3	210*208*203	45	440*400*230	180

Recommended Soldering Profile for Rectifier Diodes (Pb Free)

a) Wave Soldering Profile

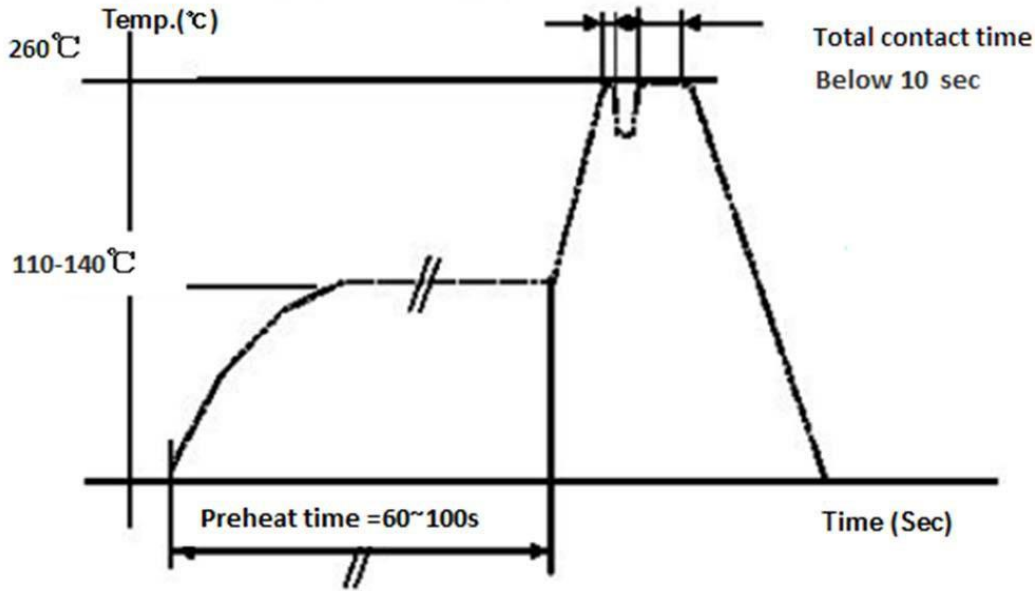

b) Reflow Soldering Profile (Pb Free Application), refer to IPC/JEDEC J-STD-020

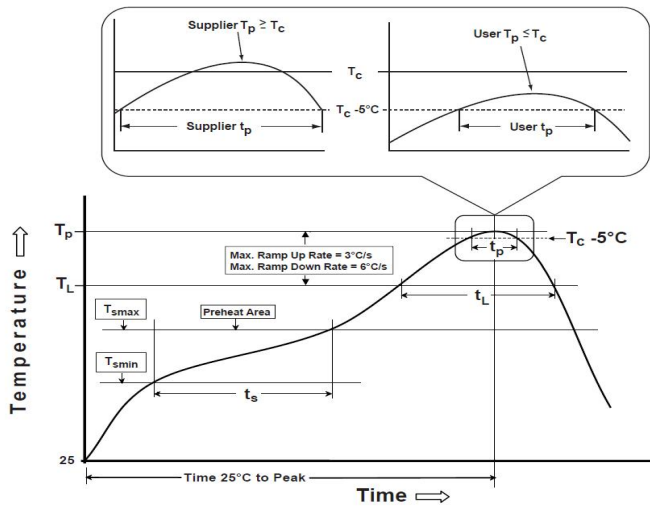

Preheat/Soak Temperature Min (T _{smin}) Temperature Max (T _{smax}) Time (t _s) from (T _{smin} to T _{smax})	50 °C 200 °C 60-120 seconds
Melting Point of Solder (Sn Ag Cu)	217°C
Ramp-up Rate to 217°C(Melting Point of Solder)	3°C/sec
Time at Temp.>217°C (Melting Point of Solder)	60~150 Sec
Peak Temperature	255±5°C
Time within 5°Cbelow Peak Temp.	20~40 Sec
Cooling Rate	6°C/sec (max)
Time from 25°C to Peak Temp.	8min (max)

c) Manual Soldering

When using an electric soldering iron for manual soldering, it is recommended that the temperature does not exceed 300°C and the soldering time is less than 10 seconds.

Package Mechanical Data

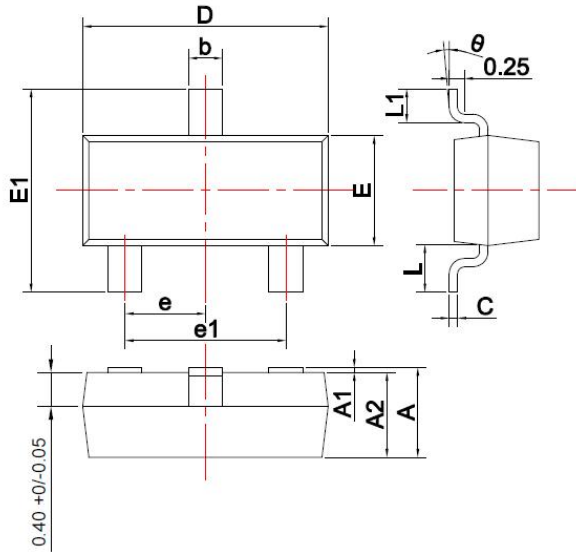

SYMBOL	DIMENSIONS	
	MIN.	MAX.
A	0.900	1.150
A1	0.000	0.100
A2	0.900	1.050
b	0.300	0.500
c	0.080	0.150
D	2.800	3.000
E	1.200	1.400
E1	2.250	2.550
e	0.950TYP	
e1	1.800	2.000
L	0.550REF	
L1	0.300	0.500
θ	0°	8°

Unit: mm

Suggested Pad Layout

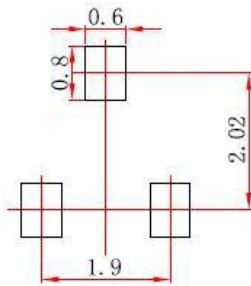

- Note:
1. Controlling dimension: In millimeters.
 2. General tolerance: ± 0.05mm.
 3. The pad layout is for reference purposes only.