



AOS
SEMICONDUCTOR

产品规格说明书

Product Data Sheet

AOS74LVC1G38xx

WEB | www.aossemi.cn 



电源管理IC



通信接口芯片



二三极管



LDO稳压器



逻辑器件



MOSFETs



运算放大器



显示驱动



MCU单片机



光电器件



AOS74LVC1G38 Single 2-Input NAND Gate with Open-Drain Output

DESCRIPTIONS

The AOS74LVC1G38 device is designed for 1.65V to 5.5V V_{CC} operation.

This device is a single two-input NAND buffer gate with open-drain output. It performs the Boolean function $Y = \overline{A \times B}$ or $Y = \overline{A + B}$ in positive logic.

This device is fully specified for partial-power-down applications using I_{off} . The I_{off} circuitry disables the outputs when the device is powered down. This inhibits current backflow into the device which prevents damage to the device.

The AOS74LVC1G38 is available in Green SOT23-5 and SC70-5 packages. It operates over an ambient temperature range of -40°C to +125°C.

FEATURES

- Operating Voltage Range: 1.65V to 5.5V
- Low Power Consumption: 1µA (Max)
- Operating Temperature Range: -40°C to 125°C
- Inputs Accept Voltage to 5.5V
- High Output Drive: ±24mA at $V_{CC}=3.0V$
- Micro Size Packages: SOT23-5, SC70-5

APPLICATIONS

- Active Noise Elimination
- Bar Code Scanner
- Blood Pressure Monitor
- CPAP Machine
- Fingerprint Identification
- Network Attached Storage(NAS)

LOGIC SYMBOL

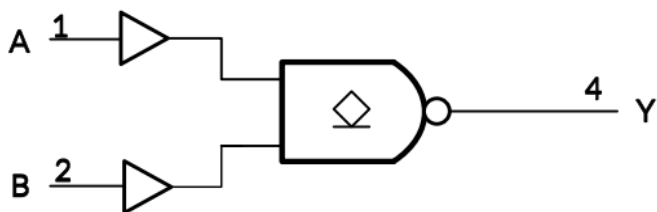

Device Information⁽¹⁾

PART NUMBER	PACKAGE	BODY SIZE (NOM)
AOS74LVC1G38	SOT23-5	2.92mm × 1.60mm
	SC70-5	2.10mm × 1.25mm

(1)For all available packages, see the orderable addendum at the end of the data sheet.

FUNCTION TABLE

INPUTS		OUTPUT
A	B	Y
H	H	L
L	H	Z
H	L	Z
L	L	Z

H=High Voltage Level
 L=Low Voltage Level
 Z=high-impedance OFF-state



PACKAGE/ORDERING INFORMATION

PRODUCT	ORDERING NUMBER	TEMPERATURE RANGE	PACKAGE LEAD	PACKAGE MARKING ⁽¹⁾	MSL ⁽³⁾	PACKAGE OPTION
AOS74LVC1G38	AOS74LVC1G38DBVR	-40°C~+125°C	SOT23-5	1G38	MSL3	Tape and Reel , 3000
	AOS74LVC1G38DCKR	-40°C~+125°C	SC70-5 ⁽⁴⁾	1G38	MSL3	Tape and Reel , 3000

NOTE:

- (1) This information is the most current data available for the designated devices. This data is subject to change without notice and revision of this document. For browser-based versions of this data sheet, refer to the right-hand navigation.
- (2) There may be additional marking, which relates to the lot trace code information (data code and vendor code), the logo or the environmental category on the device.
- (3) MSL, The Moisture Sensitivity Level rating according to the JEDEC industry standard classifications.
- (4) Equivalent to SOT353.



PIN CONFIGURATIONS

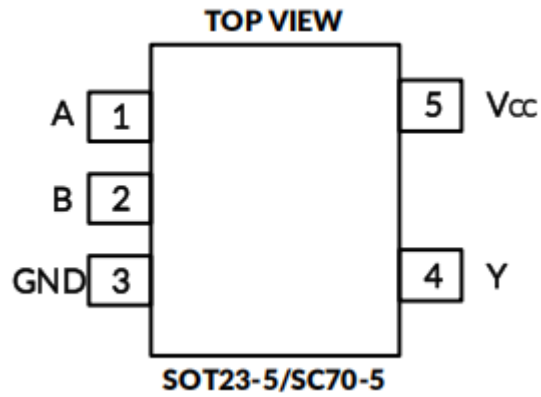

PIN DESCRIPTION

PIN	NAME	I/O TYPE ⁽¹⁾	FUNCTION
SOT23-5/SC70-5			
1	A	I	Input
2	B	I	Input
3	GND	-	Ground
4	Y	O	Output
5	Vcc	P	Power Pin

(1) I=input, O=output, P=Power.



Specifications

Absolute Maximum Ratings

Over operating free-air temperature range (unless otherwise noted)⁽¹⁾⁽²⁾

		MIN	MAX	UNIT
V _{CC}	Supply voltage range	-0.5	6.5	V
V _I	Input voltage range ⁽²⁾	-0.5	6.5	
V _O	Output voltage range ⁽²⁾	-0.5	6.5	
I _{IK}	Input clamp current	V _I <0	-50	mA
I _{OK}	Output clamp current	V _O <0	-50	
I _O	Continuous output current		± 50	mA
	Continuous current through V _{CC} or GND		± 100	
J _A	Package thermal impedance ⁽³⁾	SOT23-5	230	°C/W
		SC70-5	380	
T _J	Junction temperature ⁽⁴⁾	-65	150	°C
T _{stg}	Storage temperature	-65	150	

- (1) Stresses beyond those listed under Absolute Maximum Ratings may cause permanent damage to the device. These are stress ratings only, and functional operation of the device at these or any other conditions beyond those indicated under Recommended Operating Conditions is not implied. Exposure to absolute-maximum-rated conditions for extended periods may affect device reliability.
- (2) The input and output negative-voltage ratings may be exceeded if the input and output current ratings are observed.
- (3) The package thermal impedance is calculated in accordance with JEDEC-51.
- (4) The maximum power dissipation is a function of T_{J(MAX)}, R_{JA}, and T_A. The maximum allowable power dissipation at any ambient temperature is P_D = (T_{J(MAX)} - T_A) / R_{JA}. All numbers apply for packages soldered directly onto a PCB.



ESD Ratings

The following ESD information is provided for handling of ESD-sensitive devices in an ESD protected area only.

			VALUE	UNIT
V _(ESD)	Electrostatic discharge	Human-Body Model (HBM), per ANSI/ESDA/JEDEC JS-001 ⁽¹⁾	± 2000	V
		Charged-Device Model (CDM), per ANSI/ESDA/JEDEC JS-002 ⁽²⁾	± 1000	
		Machine Model (MM)	± 200	



ESD SENSITIVITY CAUTION

ESD damage can range from subtle performance degradation to complete device failure. Precision integrated circuits may be more susceptible to damage because very small parametric changes could cause the device not to meet its published specifications.

**ELECTRICAL CHARACTERISTICS**

over recommended operating free-air temperature range (TYP values are at $T_A=+25^{\circ}\text{C}$, Full= -40°C to 125°C , unless otherwise noted.) ⁽¹⁾

Recommended Operating Conditions

PARAMETER	SYMBOL	TEST CONDITIONS	MIN	MAX	UNIT
Supply Voltage	V_{CC}	Operating	1.65	5.5	V
		Data retention only	1.5		
High-Level Input Voltage	V_{IH}	$V_{CC}=1.65\text{V to }1.95\text{V}$	$0.65 \times V_{CC}$		
		$V_{CC}=2.3\text{V to }2.7\text{V}$	1.7		
		$V_{CC}=3\text{V to }3.6\text{V}$	2		
		$V_{CC}=4.5\text{V to }5.5\text{V}$	$0.7 \times V_{CC}$		
Low-Level Input Voltage	V_{IL}	$V_{CC}=1.65\text{V to }1.95\text{V}$		$0.35 \times V_{CC}$	
		$V_{CC}=2.3\text{V to }2.7\text{V}$		0.7	
		$V_{CC}=3\text{V to }3.6\text{V}$		0.8	
		$V_{CC}=4.5\text{V to }5.5\text{V}$		$0.3 \times V_{CC}$	
Input Voltage	V_i		0	5.5	
Output Voltage	V_o		0	V_{CC}	
Input Transition Rise or Fall	$\Delta t, \Delta t$	$V_{CC}=1.8\text{V} \pm 0.15\text{V},$ $2.5\text{V} \pm 0.2\text{V}$		20	
		$V_{CC}=3.3\text{V} \pm 0.3\text{V}$		10	
		$V_{CC}=5\text{V} \pm 0.5\text{V}$		5	
Operating Temperature	T_A		-40	+125	$^{\circ}\text{C}$

(1) All unused inputs of the device must be held at V_{CC} or GND to ensure proper device operation.



DC Characteristics

PARAMETER		TEST CONDITIONS	V _{CC}	TEMP	MIN	TYP	MAX	UNIT
V _{OL}		I _{OH} =100μA	1.65V to 5.5V	Full			0.1	V
		I _{OH} =4mA	1.65V				0.45	
		I _{OH} =8mA	2.3V				0.3	
		I _{OH} =16mA	3V				0.4	
		I _{OH} =24mA					0.55	
		I _{OH} =32mA	4.5V				0.55	
I _I	A or B inputs	V _I =5.5V or GND	0V to 5.5V	+25°C		± 0.1	± 1	μA
				Full			± 5	
I _{off}		V _I or V _O =5.5V	0	+25°C		± 0.1	± 1	
				Full			± 10	
I _{CC}		V _I =5.5V or GND, I _O =0	1.65V to 5.5V	+25°C		0.1	1	
				Full			10	
Δ I _{CC}		One input at V _{CC} -0.6V, Other inputs at V _{CC} or GND	3V to 5.5V	Full			500	
C _i (Input Capacitance)		V _I =V _{CC} or GND	3.3V	+25°C		4		pF

- (1) All unused inputs of the device must be held at V_{CC} or GND to ensure proper device operation.
- (2) Limits are 100% production tested at 25°C. Limits over the operating temperature range are ensured through correlations using statistical quality control (SQC) method.
- (3) Typical values represent the most likely parametric norm as determined at the time of characterization. Actual typical values may vary over time and will also depend on the application and configuration.



AC Characteristics

PARAMETER	SYMBOL	TEST CONDITIONS		MIN ⁽²⁾	TYP ⁽³⁾	MAX ⁽²⁾	UNIT
Propagation Delay	t_{pd}	$V_{CC}=1.8V \pm 0.15V$	$C_L=30pF, R_L=1k$		6.6		ns
		$V_{CC}=2.5V \pm 0.2V$	$C_L=30pF, R_L=500$		4.3		
		$V_{CC}=3.3V \pm 0.3V$	$C_L=50pF, R_L=500$		4.5		
		$V_{CC}=5V \pm 0.5V$	$C_L=50pF, R_L=500$		3.9		
Power dissipation capacitance	C_{pd}	$V_{CC}=1.8V$	$f=10MHz$		3		pF
		$V_{CC}=2.5V$			3		
		$V_{CC}=3.3V$			4		
		$V_{CC}=5V$			6		

- (1) All unused inputs of the device must be held at V_{CC} or GND to ensure proper device operation.
- (2) This parameter is ensured by design and/or characterization and is not tested in production.
- (3) Typical values represent the most likely parametric norm as determined at the time of characterization. Actual typical values may vary over time and will also depend on the application and configuration.



PARAMETER MEASUREMENT INFORMATION

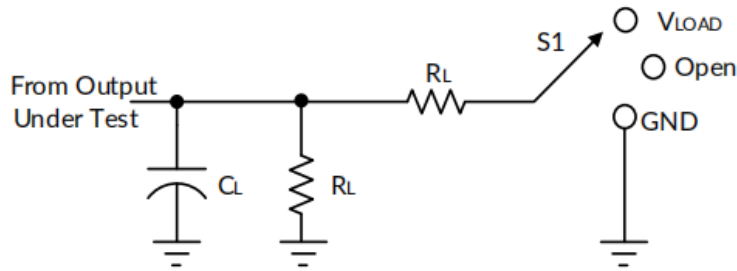

TEST	S1
t_{PLH}/t_{PHL}	Open
t_{PLZ}/t_{PZL}	V_{LOAD}
t_{PHZ}/t_{PZH}	GND

V_{CC}	INPUTS		V_M	V_{LOAD}	C_L	R_L	V
	V_i	t_r/t_f					
$1.8V \pm 0.15V$	V_{CC}	$\leq 2ns$	$V_{CC}/2$	$2 \times V_{CC}$	30pF	1k	0.15V
$2.5V \pm 0.2V$	V_{CC}	$\leq 2ns$	$V_{CC}/2$	$2 \times V_{CC}$	30pF	500	0.15V
$3.3V \pm 0.3V$	3V	$\leq 2.5ns$	1.5V	6V	50pF	500	0.3V
$5V \pm 0.5V$	V_{CC}	$\leq 2.5ns$	$V_{CC}/2$	$2 \times V_{CC}$	50pF	500	0.3V

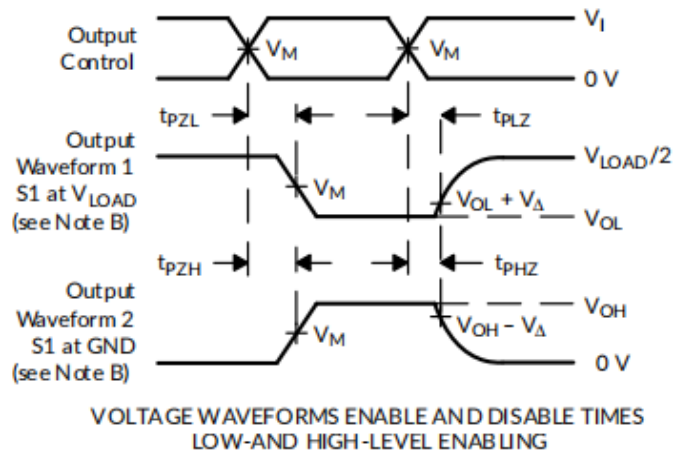
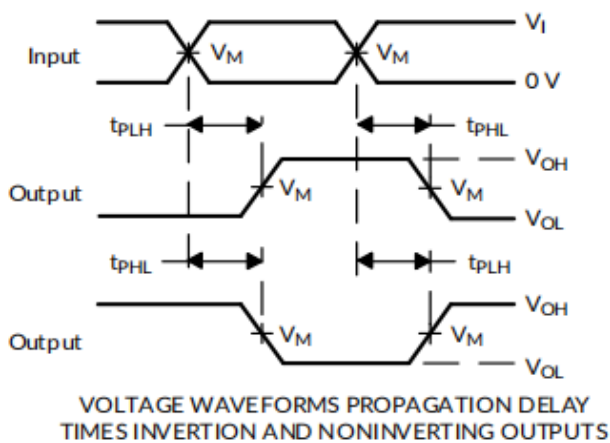
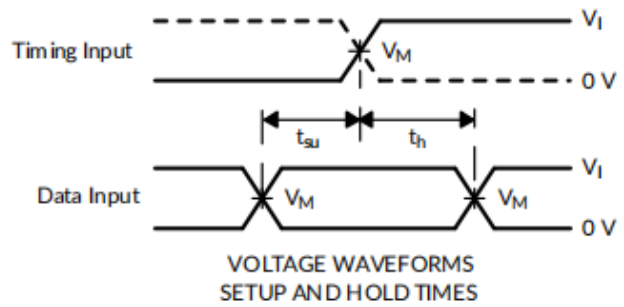
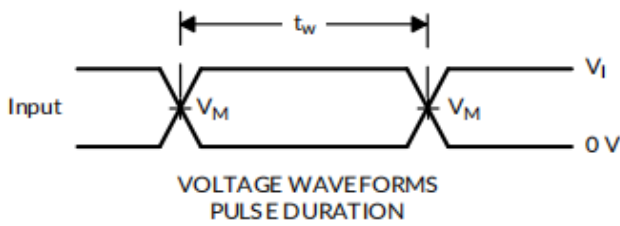



- NOTES:
- A. C_L includes probe and jig capacitance.
 - B. Waveform 1 is for an output with internal conditions such that the output is low, except when disabled by the output control.
Waveform 2 is for an output with internal conditions such that the output is high, except when disabled by the output control.
 - C. All input pulses are supplied by generators having the following characteristics: $PRR \leq 10$ MHz, $Z_0 = 50 \Omega$.
 - D. The outputs are measured one at a time, with one transition per measurement.
 - E. t_{PLZ} and t_{PHZ} are the same as t_{dis} .
 - F. t_{PZL} and t_{PZH} are the same as t_{en} .
 - G. t_{PLH} and t_{PHL} are the same as t_{pd} .
 - H. All parameters and waveforms are not applicable to all devices.

Figure 1. Load Circuit and Voltage Waveforms



PACKAGE OUTLINE DIMENSIONS
SOT23-5⁽³⁾

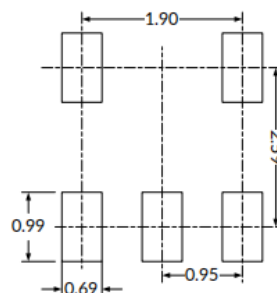
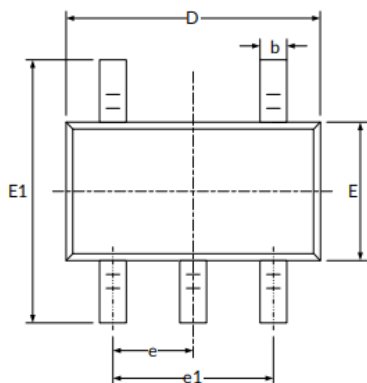

RECOMMENDED LAND PATTERN (Unit: mm)

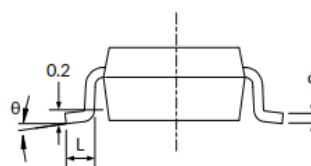
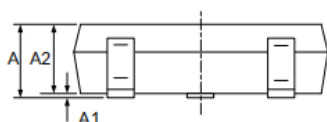

Symbol	Dimensions In Millimeters		Dimensions In Inches	
	Min	Max	Min	Max
A ⁽¹⁾	1.050	1.250	0.041	0.049
A1	0.000	0.100	0.000	0.004
A2	1.050	1.150	0.041	0.045
b	0.300	0.500	0.012	0.020
c	0.100	0.200	0.004	0.008
D ⁽¹⁾	2.820	3.020	0.111	0.119
E ⁽¹⁾	1.500	1.700	0.059	0.067
E1	2.650	2.950	0.104	0.116
e	0.950(BSC) ⁽²⁾		0.037(BSC) ⁽²⁾	
e1	1.800	2.000	0.071	0.079
L	0.300	0.600	0.012	0.024
	0°	8°	0°	8°

NOTE:

1. Plastic or metal protrusions of 0.15mm maximum per side are not included.
2. BSC (Basic Spacing between Centers), "Basic" spacing is nominal.
3. This drawing is subject to change without notice.



SC70-5⁽³⁾

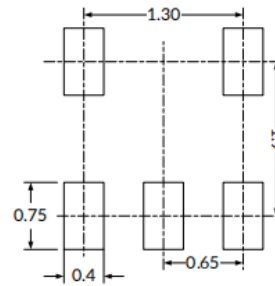
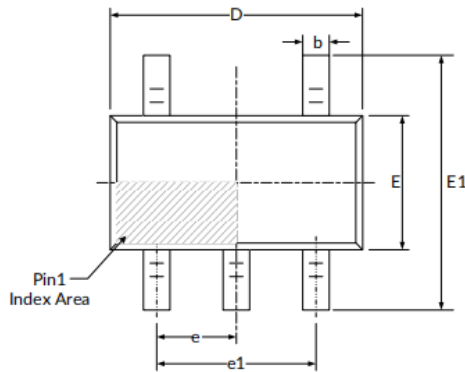

RECOMMENDED LAND PATTERN (Unit: mm)

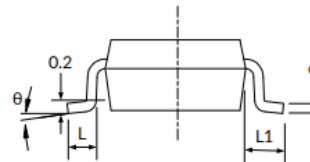
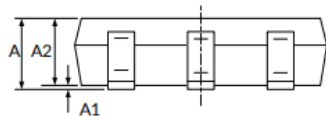

Symbol	Dimensions In Millimeters		Dimensions In Inches	
	Min	Max	Min	Max
A ⁽¹⁾	0.900	1.100	0.035	0.043
A1	0.000	0.100	0.000	0.004
A2	0.900	1.000	0.035	0.039
b	0.150	0.350	0.006	0.014
c	0.080	0.150	0.003	0.006
D ⁽¹⁾	2.000	2.200	0.079	0.087
E ⁽¹⁾	1.150	1.350	0.045	0.053
E1	2.150	2.450	0.085	0.096
e	0.650(BSC) ⁽²⁾		0.026(BSC) ⁽²⁾	
e1	1.300(BSC) ⁽²⁾		0.051(BSC) ⁽²⁾	
L	0.260	0.460	0.010	0.018
L1	0.525		0.021	
	0°	8°	0°	8°

NOTE:

1. Plastic or metal protrusions of 0.15mm maximum per side are not included.
2. BSC (Basic Spacing between Centers), "Basic" spacing is nominal.
3. This drawing is subject to change without notice.



TAPE AND REEL INFORMATION

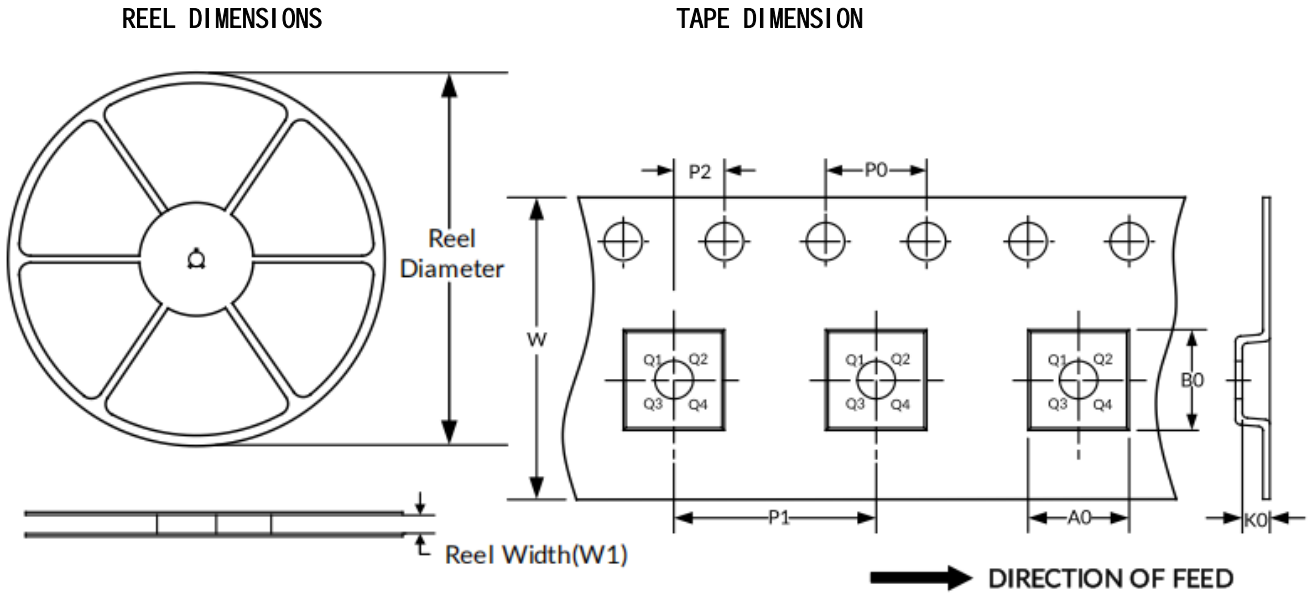

NOTE: The picture is only for reference. Please make the object as the standard.

KEY PARAMETER LIST OF TAPE AND REEL

Package Type	Reel Diameter	Reel Width(mm)	A0 (mm)	B0 (mm)	K0 (mm)	P0 (mm)	P1 (mm)	P2 (mm)	W (mm)	Pin1 Quadrant
SC70-5	7''	9.5	2.25	2.55	1.20	4.0	4.0	2.0	8.0	Q3
SOT23-5	7''	9.5	3.20	3.20	1.40	4.0	4.0	2.0	8.0	Q3

NOTE:

1. All dimensions are nominal.
2. Plastic or metal protrusions of 0.15mm maximum per side are not included.