

东莞市高钺达电子科技有限公司

DONGGUAN GAOYUEDA ELECTRONICS COLTD

承 认 书

SPECIFICATION FOR APPROVAL

Customer : _____

Description : TYPE C 16PIN沉板0.8带钢片

Part No. : TPS08-N1F1-2016-A

Customer P/N : _____

东莞市高钺达电子科技有限公司		客 户	
工程 承 认 章		工程 承 认 章	
品 管 承 认 章		品 管 承 认 章	

TAIWAN FACTORY: 協昌精密工業股份有限公司

ADD: NO. 95 Twopart Southharbour road, Taibei, Taiwan. CHINA

地址: 中国臺灣台北市南港路二段 95 號

TEL: 02-27884666 FAX: 02-26535492

<http://www.twshetime.com>

CHINA FACTORY: 东莞市高钺达电子科技有限公司

地址 东莞市大岭山镇太公岭村莞长路110号2栋

TEL: 13570841301 微信同号 TEL: 13412512525 微信同号

E-mail: szgaosuda@163.com

REV.	DESCRIPTION	APPD	DATE

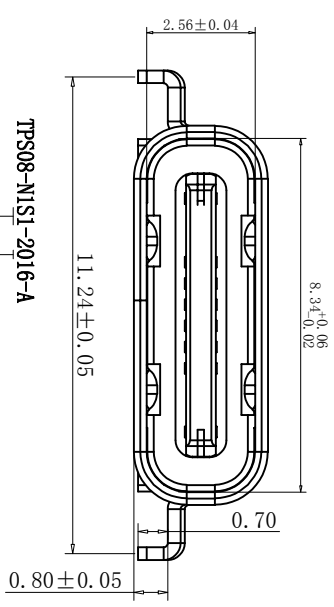
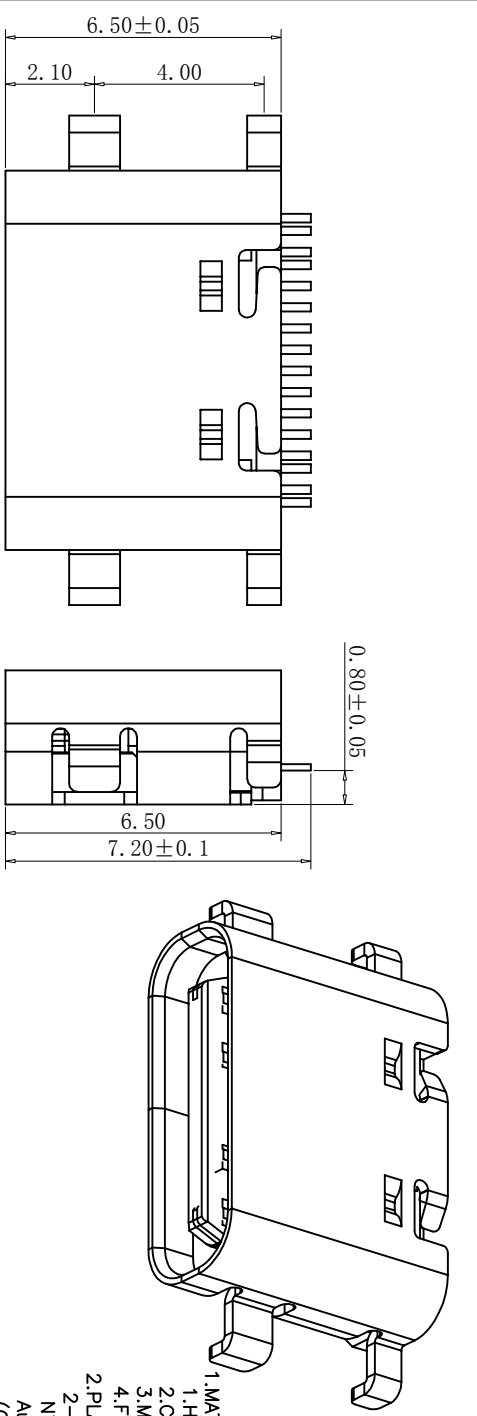

0 普通外壳
1 点焊外壳
S1 半金锡端子
P1 全金端子

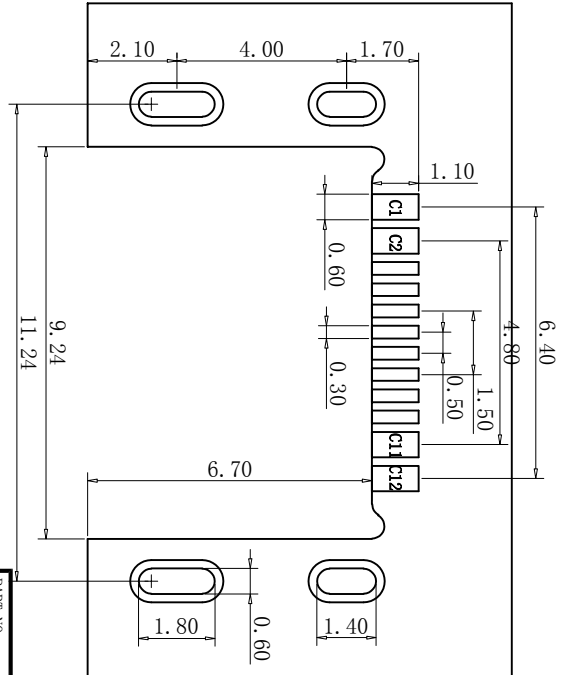

16 PIN USB Type-C Receptacle Interface (Front View)

PIN NO.	A1/B12	A4/B9	B8	A5	B7	A6	A7	B6	A8	B5	B4/A9	B1/A12
SIGNAL NAME	GND	Vbus	SBU2	CC1	D-	D+	D-	D+	SBU1	CC2	Vbus	GND
PCB PAD NO.	C1	C2	C3	C4	C5	C6	C7	C8	C9	C10	C11	C12

- MATERIAL SPECIFICATION:
 - HOUSING:HIGH TEMPERATURE RESISTANT PLASTIC,UL94 V-0.
 - CONTACTS:COPPER ALLOY
 - MD PLATE: STAINLESS STEEL
 - FRONT SHELL: STAINLESS STEEL
- PLATING SPECIFICATION:
 - CONTACTS:
 - Ni 40u" MIN. UNDER PLATED OVER ALL.
 - AU PLATED ON THE FUNCTIONAL AREA OF CONTACT.
 - FRONT SHELL:
 - (GOLD PLATING THICKNESS FOLLOW THE P/N)
 - PLATING SPECIFICATIONS OF THE SOLDER AREA FOLLOW THE P/N
- FRONT SHELL: SEE TABLE1.
- SHIELD PLATE&EMI PLATE: CLEAR ONLY
- MECHANICAL PERFORMANCE,
 - INSERTION FORCE: 0.5~2.0N.
 - REMOVAL FORCE: 0.8N~2.0N.
 - DURABILITY: 10000 CYCLES.
- ELECTRICAL PERFORMANCE,
 - CURRENT RATING:5.0A
 - VOLTAGE RATING:5.0V
- LCR:
 - VBUS & GND PINS AND OTHER PINS: 40mΩ/PIN MAX.
 - SHIELD: 50mΩ/MAX.
 - LCR MAX. CHANGE OF ALL PINS: 10mΩ.
- INSULATION RESISTANCE: 100MΩ MIN
- DIELECTRIC WITHSTAND VOLTAGE:AC 100V FOR 1 MINUTE.
- ENVIRONMENTAL PERFORMANCE:
 - OPERATING TEMPERATURE: -25°C~+85°C.
 - IR REFLOW:
 - THE PEAK TEMPERATURE ON THE BOARD SHALL BE MAINTAINED FOR 10 SECONDS AT 260°C.

PART NO: TPS08-NISI-2016-A	MATERIAL:	东莞市高敏达电子科技有限公司	
LOT NO:	FINISH:		
UNIT: MM	SIZE: A4	COLOR:	
TOLERANCES: X.X±0.35 X.XX±0.25 X.XXX±0.15	GENERAL ANGLE: X.X±3.0° X.XX±2.0°	DR: 刘静	TITLE: TYPE C 16pin 母座 沉板0.8(铜片)
		CHK:	DWG NO: FP-090012
		APP:	SCALE: 1:1
			SHEET: 1 OF 1
			REV: A

REV	DESCRIPTION	APPD	DATE

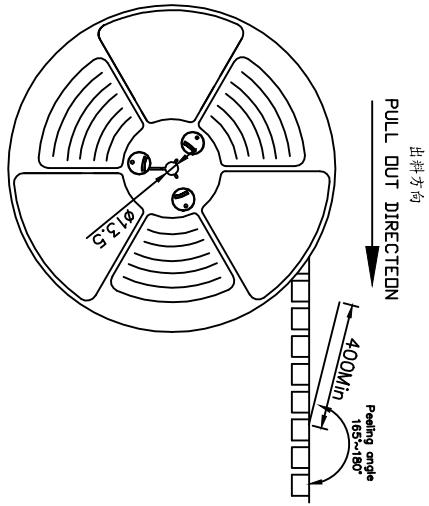

NOTES

1. 带子引線長度
LEAD TAPE LENGTH
出料方向 PULL OUT DIRECTION

出料方向 PULL OUT DIRECTION

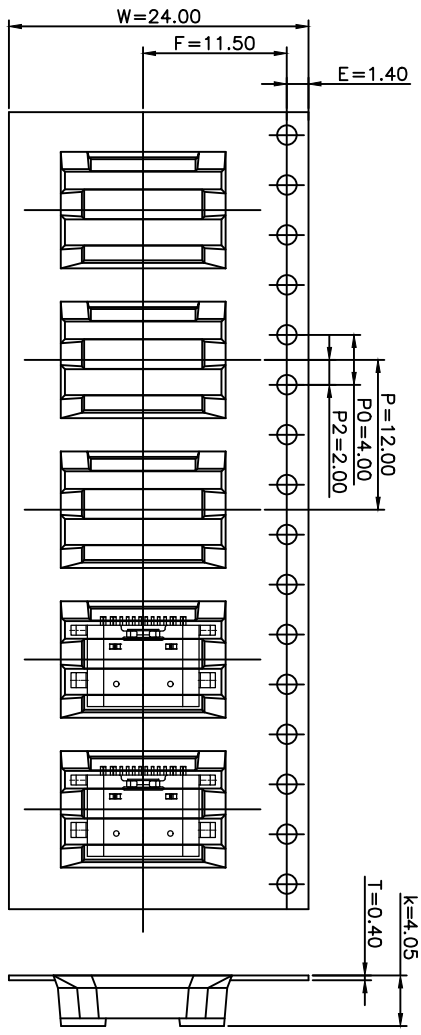
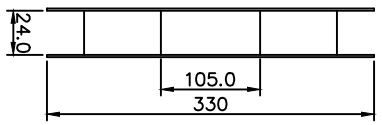
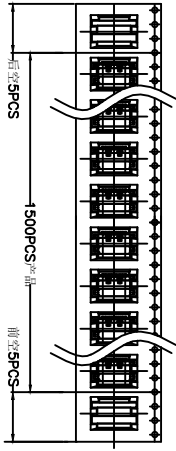

TAPE & REEL 10 PCS
= 1500 PCS

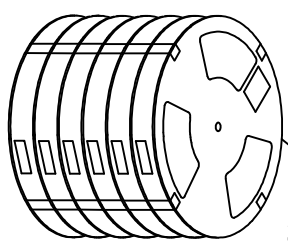

BOX
DIMENSIONS:
33.5X33.5X30.5

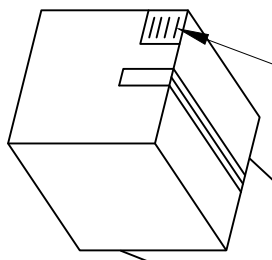

1 CARTON
= 10 REELS
= 15000 PCS

PART NO:		MATERIAL:	
LOT NO:		FINISH:	
UNIT: MM	SIZE: A4	COLOR:	
TOLERANCES:		DR: 刘静	
X, X=±0.35	GENERAL	CHK:	
X, XX=±0.25	ANGLE:	APP:	
X, XX=±0.15	X, X=±3.0°	SCALE: 1:1	
	X, XX=±2.0°	SHEET: 1 OF 1	
TITLE: 东莞市高铖达电子科技有限公司		DWG NO: FP-090012	
TYPE C 16pin 沉板母座		REV: A	

3/8



USB C type series connectors Product Specification	DOC. No.DB-SP-006		Rev.: A5	Page:1/5
	Approved/Date	Checked/Date	Written/Date	
	卢楚 2018/01/05	卢楚 2018/01/05	LXH 2018/01/05	

1.0 Scope : This specification covers the requirements for product performance and test methods of USB C TYPE Series Connectors of the part numbers specified as bellow.
Product shall be of the design, construction and physical dimensions specified in the applicable product drawing.

2.0 Rating :

- 2.1 Current Rating : VBUS pins(A4,B4,A9 and B9)&GND pins(A1,B1 ,B12 and A12) 5.0A(1.25A /Pin)
Other pins 0.25A/Pin
- 2.2 Temperature Range: storage : -20°C to +60°C ;
operating : -30°C to +80°C ;
Humidity: 90% Rh max.

3.0 Test Condition:

All tests shall be performed as bellow conditions unless otherwise specified.

- 3.1 Temperature range : +15°C to +35°C
- 3.2 Humidity range: 90% Rh max

4.0 Test Methods and Requirements:

4.1 Examination of product:

Item	Test Description	Test Methods	Requirement
4.1.1	Examination of product (Outward Appearance Structure)	EIA 364-18 Shall be confirmed with eyes in accordance with each drawing. Shall be confirmed by using proper measuring instruments.	1).Outward appearance shall be good without such injurious problem 2).Structure shall be meet the design and dimensional requirements of drawing.

4.2 Electrical Performance:

Item	Test Description	Test Methods	Requirement
4.2.1	Low Level Contact Resistance	EIA 364-23 (or MIL-STD-1344A, Method 3002.1, Test Condition B) 30m Ω (Max) when measured at 20mv(max) open circuit at 100mA.Contact resistance below 40 m Ω after 10000 insertion/extraction cycles at a maximum rate of 500 cycles per hour	40 mΩ Maximum

		USB C type series connectors Product Specification	DOC. No.DB-SP-006	Rev.: A5	Page:2/5
			Approved/Date	Checked/Date	Written/Date
			卢楚 2018/01/05	卢楚 2018/01/05	LXH 2018/01/05
4.2.2	Insulation Resistance	EIA 364-21 (or MIL-STD-202F, Method 302, Test Condition B) D.C 500 V is applied between adjacent contacts and insulation resistance is measured within 1 minute.	100 MΩ Minimum		
4.2.3	Dielectric Withstanding Voltage	EIA 364-20 (or MIL-STD-202F, Method 301, Test Condition B) Test between adjacent contacts of mated and unmated connector assemblies. The object of this test procedure is to detail a test method to prove that a MICRO USB connector can operate safely at its rated voltage and withstand momentary over potentials due to switching, surges and/or other similar phenomena.	There shall be no shortcircuiting and damage detected at AC 100 V R.M.S for 1 minute.		
4.3 Mechanical Performance: (Continued)					
Item	Test Description	Test Methods	Requirement		
4.3.1	Insertion Force	EIA 364-13 The insertion force test shall be done at a maximum rate of 12.5mm/min.	0.5~2.0kgf		
4.3.2	Extraction Force	EIA 364-13 The extraction force test shall be done at a maximum rate or 12.5mm/min.	0.8~2.0kgf		
4.3.3	Durability	EIA 364-09 Mate and unmate Connector assemblies for 10000 cycles at maximum rated of 500 cycles per hour. Flip Interval: Every 2500 cycles	1) No flashover or insulation breakdown 2) Extraction Force: 1-1000cycles: 0.8~2.0kgf 1000~10000cycles: 0.6~2.0kgf 3)Contact Resistance: Max.50mΩ		
4.3.4	Mechanical Shock	EIA-364-27B Subject mated connector to 50G's half-sine shock pulses of 11msec duration. Three shocks in each direction applied along three mutual perpendicular planes for a total of 18	No discontinuities of 1 microsecond or long duration. See note		

		USB C type series connectors Product Specification	DOC. No.DB-SP-006	Rev.: A5	Page:3/5
			Approved/Date	Checked/Date	Written/Date
			卢楚 2018/01/05	卢楚 2018/01/05	LXH 2018/01/05
		shocks			
4.3.5	Vibration	EIA-364-28 Subject mated connectors to 10~55~10Hz traversed in 1 minute at 1.52mm amplitude 2 hours each of 3 mutually perpendicular planes.	No discontinuities of 1 microsecond or long duration. See note		
4.4 Environmental Performance:					
Item	Test Description	Test Methods	Requirement		
4.4.1	Thermal Shock	EIA 364-32, Test Condition I, (or MIL-202F, Method 107G Condition A.) Subject mated connectors to ten cycles between -30°C to +80°C. The object of this test is to determine the resistance of a micro usb connector to exposure at extremes of high and low temperatures and to the shock of alternate exposures to these extremes, simulating the worst case conditions for storage, transportation and application.	1). Shall meet visual requirement, show no physical damage. 2). Shall meet requirements of additional tests as specified in test sequence in Section 5		
4.4.2	Humidity	EIA 364-31, Test Condition A Method III, (or MIL-202F, Method 103B Test Condition B.) Subject mated connectors to 168 Hours (seven complete cycles) The object of this test procedure is to detail a standard method for the evaluation of the properties of materials used in Micro USB connectors as these influenced by the effects of high humidity and heat.	1). Shall meet visual requirement, show no physical damage. 2). Shall meet requirements of additional tests as specified in test sequence in Section 5		
4.4.3	Salt Spray	MIL-STD-202F, Method 101D, Test Condition B Subject mated connectors to 24 hours at 35 °C with 5%-Salt-solution concentration.	1). Shall meet visual requirement, show no physical damage. 2). Shall meet requirements of additional tests as specified in test sequence in Section 5		

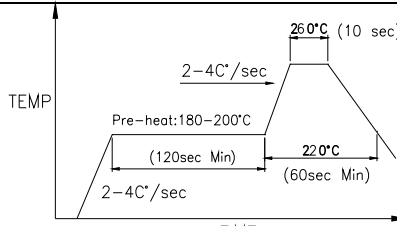
		USB C type series connectors Product Specification	DOC. No.DB-SP-006		Rev.: A5	Page:4/5
			Approved/Date		Checked/Date	Written/Date
			卢楚 2018/01/05		卢楚 2018/01/05	LXH 2018/01/05
4.4.4	Temperature Life	EIA 364-17 Test Condition 3 Method A, Subject mated connectors to temperature life at 80°C for 250hours		1). Shall meet visual requirement, show no physical damage. 2). Shall meet requirements of additional tests as specified in test sequence in Section 5		
4.4 Environmental Performance: (Continued)						
Item	Test Description	Test Methods			Requirement	
4.4.5	Solderability	EIA 364-52 After one hour steam aging. The object of test procedure is to detail a uniform test methods for determining micro usb connectors solderability. The test procedure contained here utilizes the solder dip technique. It is not intended to test or evaluate solder cup, solder eyelet, other hand-soldered type or SMT type terminations.			The surface of the portion to be soldered shall at least 95% covered with new solder coating, as specified in Category 2.	
4.4.6	Resistance to Soldering Heat	1) for WAVE SOLDE RING : MIL-STD-202F, Method 210A, Test Condition B. Pre-heat : 80°C, 60 Seconds Temperature : 260 ± 5 °C Immersion duration : 10 ± 1 sec.			1). No mechanical defect on housing or other parts.	
		2) for REFLOW SOLDERING : EIAJ RCX-0101/102. Pre-heat : 150(Min)~200(Max) °C, 60 ~180 Seconds Temperature : 260 ± 5 °C Immersion duration : 10~40 sec.				
						

	USB C type series connectors Product Specification	DOC. No.DB-SP-006		Rev.: A5	Page:5/5
		Approved/Date		Checked/Date	Written/Date
		卢楚 2018/01/05		卢楚 2018/01/05	LXH 2018/01/05

5.0 Test Sequence:									
Test Group (a)		Sample Groups							
Test Item	Test Description	A	B	C	D	E	F	G	
4.1.1	Examination of product	1, 13	1, 5	1, 8	1, 3	1, 5	1, 3	1, 6	
4.2.1	Low Level Contact Resistance	2, 10	2, 4			2, 4		2, 5	
4.2.2	Insulation Resistance	3, 11		2, 6					
4.2.3	Dielectric Withstanding Voltage	4, 12		3, 7					
4.3.1	Insertion Force	5, 8							
4.3.2	Extraction Force	6, 9							
4.3.3	Durability	7							
4.3.4	Mechanical Shock							3	
4.3.5	Vibration						4		
4.4.1	Thermal Shock			5					
4.4.2	Humidity			4					
4.4.3	Salt Spray		3						
4.4.4	Temperature Life(see note c)					3			
4.4.5	Solderability			2					
4.4.6	Resistance to Soldering Heat						2		
Number of Test Samples (Minimum)		5	5	5, 5		5	5, 5		