

## 1.5A Ultra-small Load Switch with Slew Rate Control

### Features

- Integrated P-channel MOSFET load switch
- Input voltage: 1V to 5.5V
- 1.5A maximum continuous switch current
- Switch on-resistance(typ.):  
Rdson=52mΩ at VIN=5.5V  
Rdson=57mΩ at VIN=4.2V  
Rdson=64mΩ at VIN=3.3V  
Rdson=76mΩ at VIN=2.5V  
Rdson=100mΩ at VIN=1.8V  
Rdson=164mΩ at VIN=1.2V  
Rdson=230mΩ at VIN=1V
- Controlled slew rate to limit inrush currents
- Ultra-low shutdown current
- Internal EN pull-down resistor
- Quick Output Discharge(QOD)
- Full time Reverse Current Protection (RCP) for AW35113S
- WLCSP 0.618mm×0.618mm-4B package

### Applications

Smartphones and Tablets

Portable Devices

Wearables

### Typical Application Circuit

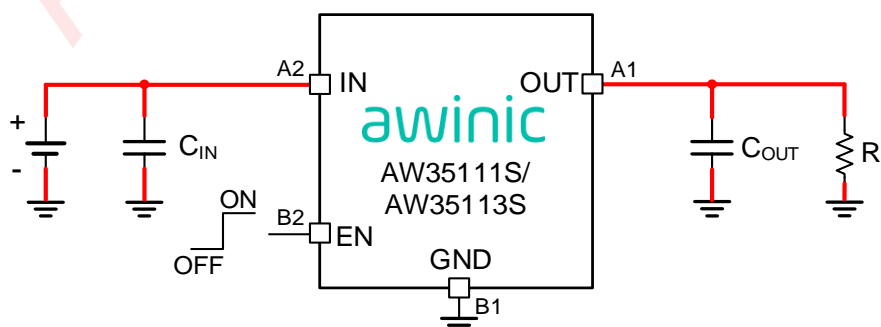

Figure 1 Typical Application Circuit of AW35111S/AW35113S

### General Description

The AW35111S/AW35113S integrates a 64mΩ (typ.) P-channel MOSFET, which can operate over a wide input range of 1V to 5.5V. The AW35111S/AW35113S features output slew rate control, limiting inrush currents during turn-on to protect downstream devices.

In addition, AW35111S/AW35113S has QOD function which can prevent the output from floating when the switch is disabled. A smart pull-down resistor is used to the EN pin during initial power-up and disconnects once the EN pin voltage reaches the  $V_{IH}$  level, then the standby current is very low and power loss can be reduced.

There is a Reverse Current Protection(RCP) function for AW35113S when  $V_{OUT}$  is 33mV(typ.) greater than  $V_{IN}$ , which can prevent the current to flowing through the P-FET or the body diode.

The AW35111SCSR/AW35113SCSR is available in WLCSP 0.618mm×0.618mm-4B package.

## Pin Configuration And Top Mark

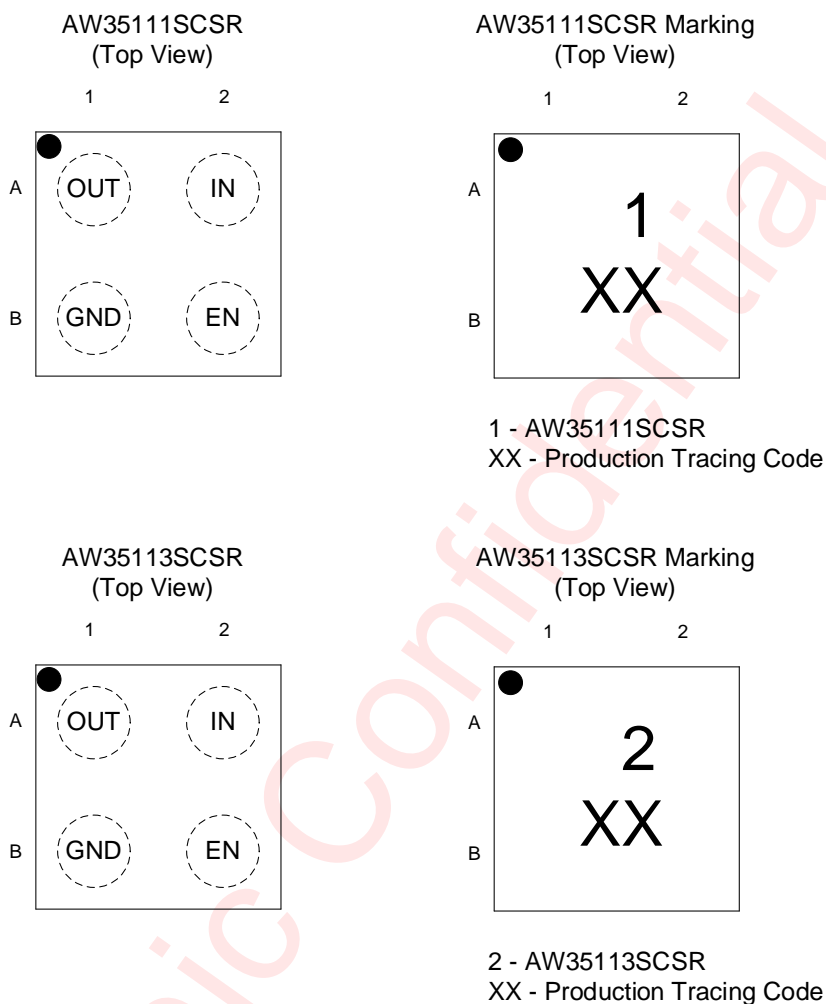

**Figure 2 Pin Configuration and Top Mark**

## Pin Definition

Pin	Name	Description
A1	OUT	Switch output
A2	IN	Switch input and power supply
B1	GND	Device ground
B2	EN	Switch control input, active high, internal 7.2MΩ pull down resistor

## Functional Block Diagram

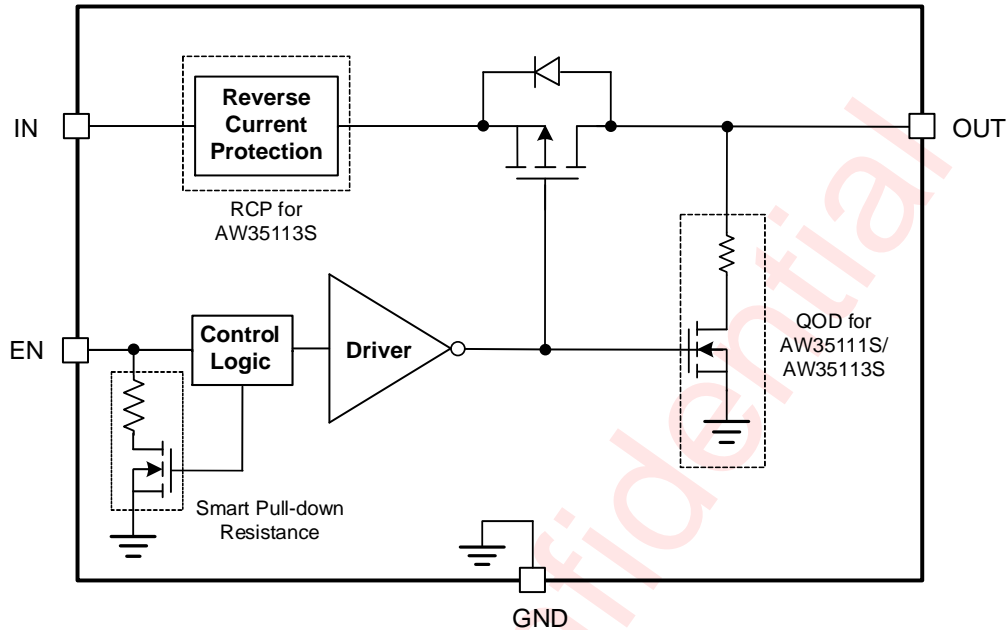

Figure 3 Functional Block Diagram

## Typical Application Circuits

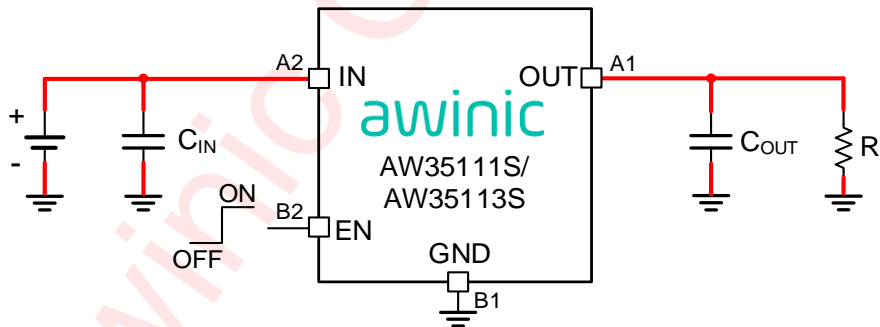

Figure 4 Typical Application Circuit of AW35111S/AW35113S

## Ordering Information

Part Number	Temperature	Package	Marking	Moisture Sensitivity Level	Environmental Information	Delivery Form
AW35111SCSR	-40°C ~ 85°C	WLCSP 0.618mm×0.618mm-4B	1	MSL1	ROHS+HF	4500 units/ Tape and Reel
AW35113SCSR	-40°C ~ 85°C	WLCSP 0.618mm×0.618mm-4B	2	MSL1	ROHS+HF	4500 units/ Tape and Reel

## Absolute Maximum Ratings<sup>(NOTE1)</sup>

PARAMETERS		RANGE
Supply Voltage Range $V_{IN}$		-0.3V to 6V
Enable Voltage Range	EN	-0.3V to 6V
Output Voltage Range	OUT	-0.3V to 6V
Maximum Continuous Switch Current $V_{IN} \geq 1.5V$		1.5A
Maximum Continuous Switch Current for $1.2V \leq V_{IN} < 1.5V$ <sup>(NOTE 2)</sup>		1A
Maximum Continuous Switch Current for $1V \leq V_{IN} < 1.2V$ <sup>(NOTE 2)</sup>		0.5A
Maximum Peak Switch Current for $V_{IN} \geq 2.5V$ <sup>(NOTE 3)</sup>		2A
Operating Free-air Temperature Range		-40°C to 85°C
$P_D$ (Power Dissipation) at $T_A=25^\circ C$		0.81W
Maximum Junction Temperature $T_{JMAX}$		150°C
Storage Temperature $T_{STG}$		-65°C to 150°C
Lead Temperature (Soldering 10 Seconds)		260°C
ESD		
HBM (Human Body Model) <sup>(NOTE 4)</sup>		±2kV
CDM(Charged Device Model) <sup>(NOTE 5)</sup>		±1.5kV
Latch-Up		
Latch-Up <sup>(NOTE 6)</sup>		+IT: 200mA -IT: -200mA

**NOTE1:** Conditions out of those ranges listed in "absolute maximum ratings" may cause permanent damages to the device. In spite of the limits above, functional operation conditions of the device should within the ranges listed in "recommended operating conditions". Exposure to absolute-maximum-rated conditions for prolonged periods may affect device reliability.

**NOTE2:** Limited by thermal design.

**NOTE3:** Limited by thermal design, and tested in 10ms width pulse current.

**NOTE4:** The human body model is a 100pF capacitor discharged through a 1.5kΩ resistor into each pin. Test method: ANSI/ESDA/JEDEC JS-001-2024.

**NOTE5:** All pins. Test Condition: ANSI/ESDA/JEDEC JS-002-2022.

**NOTE6:** Test Condition: JESD78F.

## Recommended Operating Conditions

Symbol	Parameter	Min.	Typ.	Max.	Unit
$V_{IN}$	Input Voltage	1		5.5	V
$V_{EN}$	EN Voltage	0		5.5	V
$V_{OUT}$	Output Voltage	0		$V_{IN}$	V
$C_{IN}$	Input capacitance	0.1	1		μF
$C_{OUT}$	Output load capacitance <sup>(NOTE7)</sup>	0.1	1		μF

**NOTE7:** The Output load capacitance is the nominal value.

## Electrical Characteristics

T<sub>A</sub> = 25°C unless otherwise noted. Typical values are guaranteed for V<sub>IN</sub> = 3.3V, C<sub>IN</sub> = 1μF, I<sub>IN</sub> ≤ 1.5A.

PARAMETER		TEST CONDITION		MIN	TYP	MAX	UNIT
<b>INPUT CURRENTS</b>							
I <sub>Q</sub>	Input quiescent current	AW35111S	V <sub>IN</sub> =V <sub>EN</sub> =3.3V, I <sub>OUT</sub> =0A, T <sub>A</sub> =25°C		2		nA
			V <sub>IN</sub> =V <sub>EN</sub> =3.3V, I <sub>OUT</sub> =0A, T <sub>A</sub> =85°C		8		nA
			V <sub>IN</sub> =V <sub>EN</sub> =5.5V, I <sub>OUT</sub> =0A, T <sub>A</sub> =25°C		3		nA
			V <sub>IN</sub> =V <sub>EN</sub> =5.5V, I <sub>OUT</sub> =0A, T <sub>A</sub> =85°C		15		nA
		AW35113S	V <sub>IN</sub> =V <sub>EN</sub> =3.3V, I <sub>OUT</sub> =0A, T <sub>A</sub> =25°C		350		nA
			V <sub>IN</sub> =V <sub>EN</sub> =3.3V, I <sub>OUT</sub> =0A, T <sub>A</sub> =85°C		400		nA
			V <sub>IN</sub> =V <sub>EN</sub> =5.5V, I <sub>OUT</sub> =0A, T <sub>A</sub> =25°C		610		nA
			V <sub>IN</sub> =V <sub>EN</sub> =5.5V, I <sub>OUT</sub> =0A, T <sub>A</sub> =85°C		730		nA
I <sub>SD</sub>	Shutdown current from IN to GND	AW35111S	V <sub>IN</sub> =3.3V, V <sub>EN</sub> =0V, T <sub>A</sub> =25°C		16		nA
			V <sub>IN</sub> =3.3V, V <sub>EN</sub> =0V, T <sub>A</sub> =85°C		1000		nA
			V <sub>IN</sub> =5.5V, V <sub>EN</sub> =0V, T <sub>A</sub> =25°C		35		nA
			V <sub>IN</sub> =5.5V, V <sub>EN</sub> =0V, T <sub>A</sub> =85°C		1650		nA
		AW35113S	V <sub>IN</sub> =3.3V, V <sub>EN</sub> =0V, T <sub>A</sub> =25°C		275		nA
			V <sub>IN</sub> =3.3V, V <sub>EN</sub> =0V, T <sub>A</sub> =85°C		1230		nA
			V <sub>IN</sub> =5.5V, V <sub>EN</sub> =0V, T <sub>A</sub> =25°C		500		nA
			V <sub>IN</sub> =5.5V, V <sub>EN</sub> =0V, T <sub>A</sub> =85°C		2150		nA
<b>POWER SWITCH</b>							
I <sub>LEAKEN</sub>	EN pin leakage current	V <sub>IH</sub> < V <sub>EN</sub> < V <sub>IN</sub> +0.3V				10	nA
R <sub>EN</sub>	Smart pull down resistor	V <sub>IN</sub> =5V, V <sub>EN</sub> =0.4V			7.2		MΩ
R <sub>DIS</sub>	Output discharge resistance	V <sub>IN</sub> =5.0V, EN disable, I <sub>OUT</sub> Sinking 2mA			88		Ω
R <sub>dson</sub>	Internal switch MOSFET on-state resistance	V <sub>IN</sub> =5.5V, I <sub>OUT</sub> =0.2A, T <sub>A</sub> =25°C			52		mΩ
		V <sub>IN</sub> =3.3V, I <sub>OUT</sub> =0.2A, T <sub>A</sub> =25°C			64		
		V <sub>IN</sub> =1.8V, I <sub>OUT</sub> =0.2A, T <sub>A</sub> =25°C			100		
		V <sub>IN</sub> =1.2V, I <sub>OUT</sub> =0.2A, T <sub>A</sub> =25°C			164		
		V <sub>IN</sub> =1V, I <sub>OUT</sub> =0.2A, T <sub>A</sub> =25°C			230		

## Electrical Characteristics(Continues)

T<sub>A</sub> = 25°C unless otherwise noted. Typical values are guaranteed for V<sub>IN</sub> = 3.3V, C<sub>IN</sub> = 1μF, I<sub>IN</sub> ≤ 1.5A.

PARAMETER		TEST CONDITION	MIN	TYP	MAX	UNIT
<b>POWER SWITCH</b>						
t <sub>R</sub>	Output rise time	V <sub>IN</sub> =3.3V, C <sub>OUT</sub> =0.1μF, R <sub>OUT</sub> =10Ω for AW3511S  V <sub>IN</sub> =3.3V, C <sub>OUT</sub> =1μF, R <sub>OUT</sub> =30Ω for AW35113S	AW35111S	84		μs
			AW35113S	274		
t <sub>ON</sub>	Switch turn on time		AW35111S	90		μs
			AW35113S	285		
t <sub>EN</sub>	Enable time		AW35111S	50		μs
			AW35113S	160		
t <sub>F</sub>	Output fall time		AW35111S	2		μs
			AW35113S	53		
t <sub>OFF</sub>	Switch turn off time		AW35111S	2.5		μs
			AW35113S	13		
V <sub>IH</sub>	EN input high threshold level		1			V
V <sub>IL</sub>	EN input low threshold level				0.4	V
<b>REVERSE CURRENT PROTECTION (RCP for AW35113S)</b>						
V <sub>REV</sub>	Reverse current voltage threshold	V <sub>IN</sub> =3.3V, C <sub>OUT</sub> =1μF		33		mV
V <sub>REV_HYS</sub>	Reverse current voltage hysteresis	V <sub>IN</sub> =3.3V, C <sub>OUT</sub> =1μF		27		mV
I <sub>REV_ACT</sub>	Reverse activation current	V <sub>IN</sub> =3.3V, C <sub>OUT</sub> =1μF, V <sub>OUT</sub> > V <sub>IN</sub>		0.5		A
I <sub>REV_PRO</sub>	Reverse protection current	V <sub>OUT</sub> - V <sub>IN</sub> > V <sub>REV</sub>		7.5		μA

## Timing Diagram

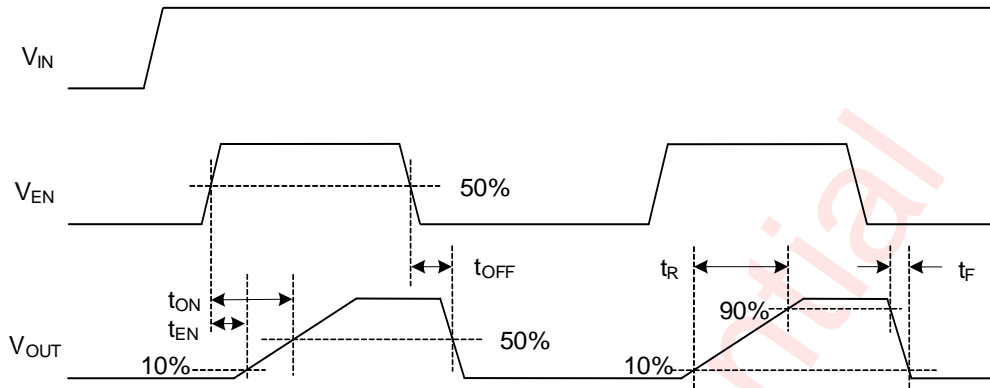

Figure 5 AW35111S/AW35113S Timing Diagram

## Typical Characteristics

Ambient temperature is 25°C,  $C_{IN} = C_{OUT} = 1\mu F$ , unless otherwise noted.

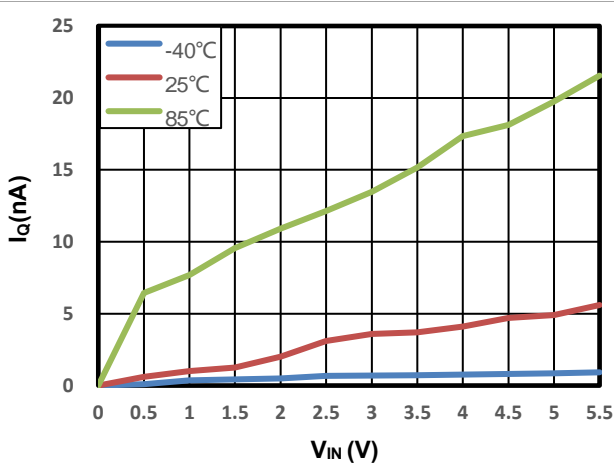

Figure 6 Quiescent Current vs.  $V_{IN}$ , No load (AW35111S)

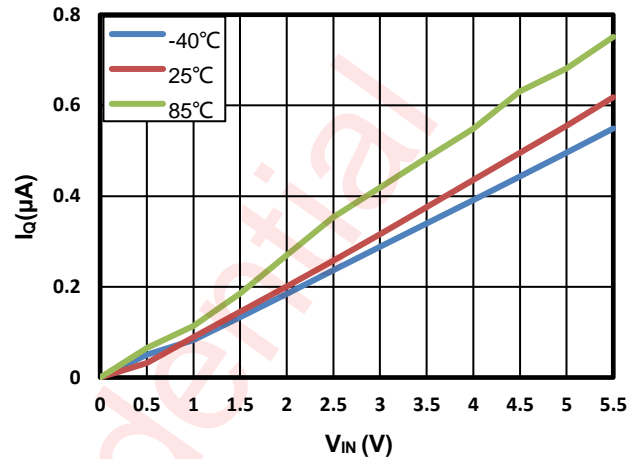

Figure 7 Quiescent Current vs.  $V_{IN}$  (AW35113S)

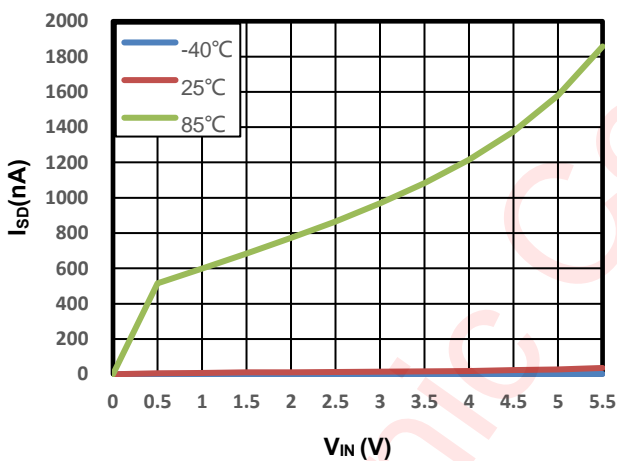

Figure 8 IN Shutdown Current vs.  $V_{IN}$  (AW35111S)

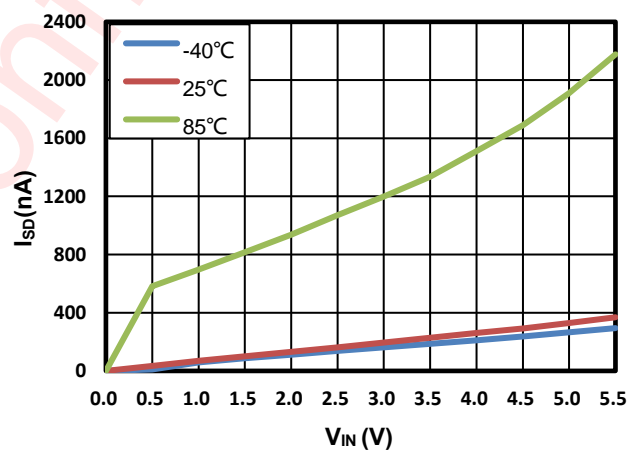

Figure 9 IN Shutdown Current vs.  $V_{IN}$  (AW35113S)

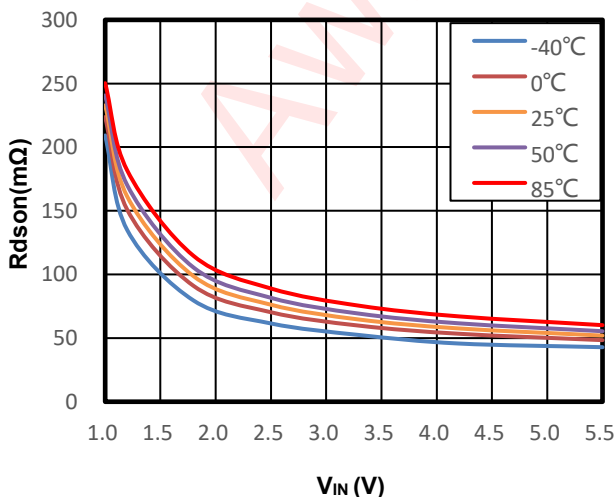

Figure 10  $R_{dson}$  vs.  $V_{IN}$  ( $I_{OUT} = 200mA$ )

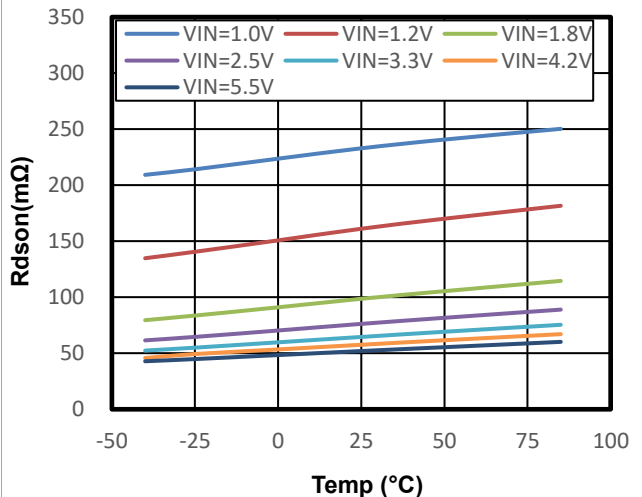
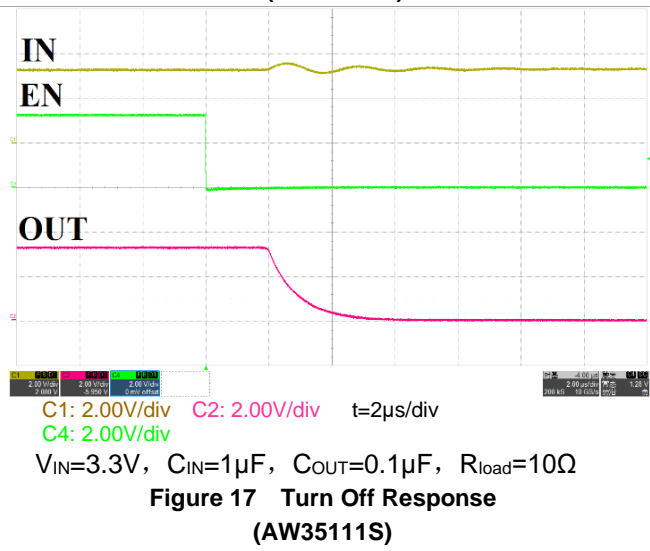
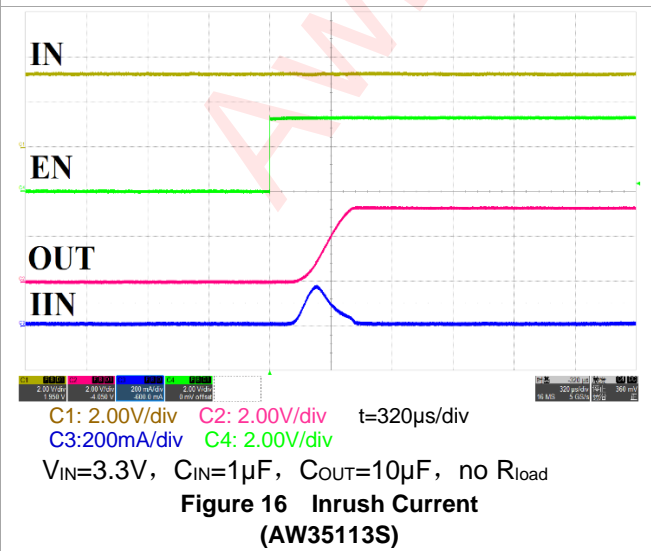
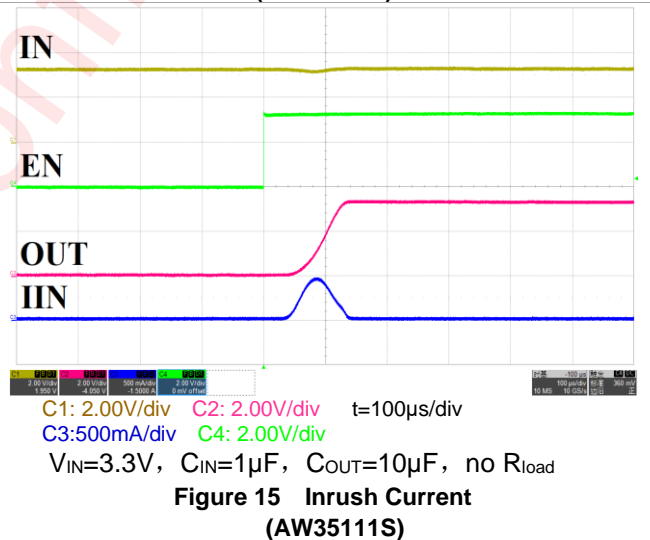
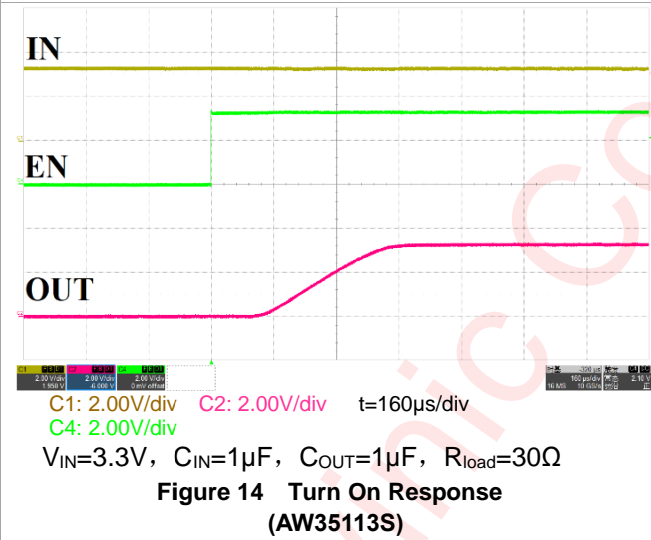
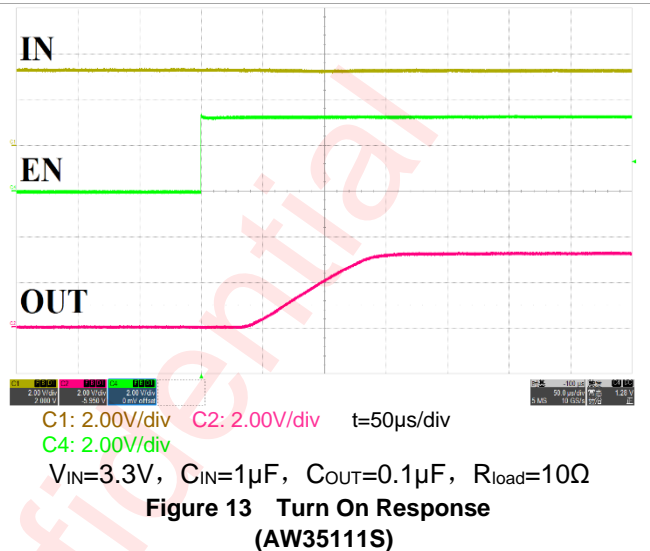
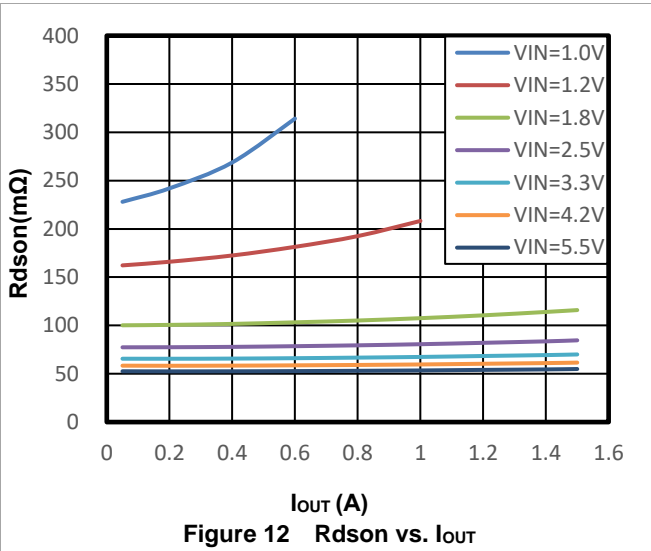
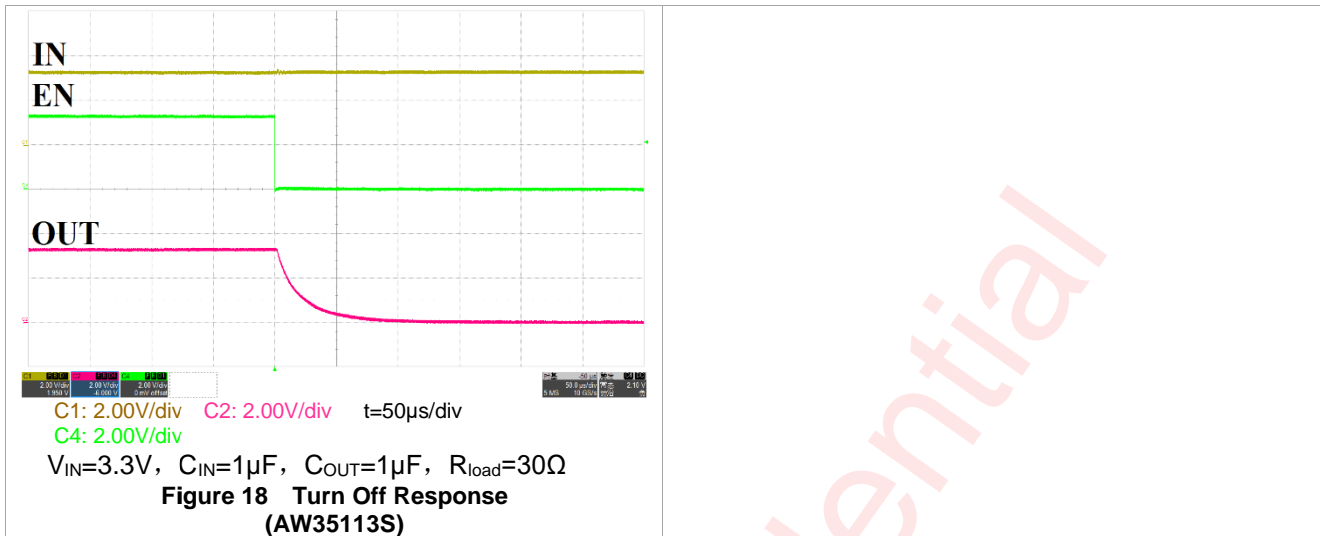

Figure 11  $R_{dson}$  vs. Temperature ( $I_{OUT} = 200mA$ )

### Typical Characteristics (continued)

Ambient temperature is 25°C,  $C_{IN} = C_{OUT} = 1\mu F$ , unless otherwise noted.





## Detailed Functional Description

The AW35111S/AW35113S integrates a high side P channel MOSFET, and provides a low on-resistance for a low voltage drop across the device. A controlled slew rate is used in applications to limit the inrush current. The part can be turned on, with a supply voltage from 1V to 5.5V.

## Turn On/Off Control

Enable pin is an active high port for AW35111S/AW35113S. The device is closed when EN pin is tied low or pulled down by internal 7.2MΩ resistor, forcing PMOS switch off. The IN/OUT path is activated with a minimum of  $V_{IN}$  of 1V and EN forced to high level.

Table 1. Functional Table

	EN	IN to OUT	OUT to GND
AW35111S/AW35113S	Low	OFF	ON
	High	ON	OFF

## Slew Rate Control

When the switch is enabled, the device regulates the gate voltage of MOSFET, and controls the  $V_{OUT}$  slew rate during  $t_R$  to avoid a large input inrush current. The feature reduces the interference to the power supply.

## Quick Output Discharge

The AW35111S/AW35113S includes the Quick Output Discharge (QOD) feature, in order to discharge the application capacitor connected on OUT pin. When EN pin is disabled, a discharge resistance with a typical value of 88Ω is connected between the output and ground, pull down the output and prevent it from floating when the device is disabled.

## Full-Time Reverse Current Protection

The AW35113S include the Reverse Current Protection(RCP) function, which can prevent the current to flowing through the P-FET or the body diode when  $V_{OUT}$  greater than  $V_{IN}$ . Whatever the switch is on or off, the AW35113S always have this function. When  $V_{OUT}-V_{IN}$  greater than  $V_{REV}$ , the internal comparator quickly turns off the switch, in order to prevent large reverse current from  $V_{OUT}$  to  $V_{IN}$ . The switch will return to normal operation once the reverse voltage scenario disappeared.

The  $I_{REV\_ACT}$  parameter in the Figure 19 can be calculated by the following formula

$$I_{REV\_ACT} = \frac{V_{REV}}{R_{dson}}$$

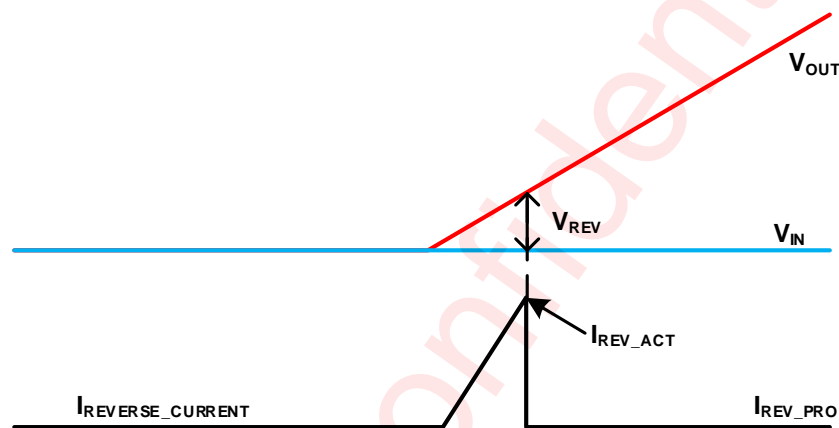

Figure 19 Reverse Current Test

## Application Information

### INPUT AND OUTPUT CAPACITANCE

Input and output capacitance improves the performance of the device, the actual capacitance should be optimized for the particular application. For all applications, a  $1\mu\text{F}$  or greater ceramic bypass capacitor between  $V_{IN}$  and GND is recommended as close to the device as possible. This precaution reduces ringing on the input due to power supply transients. Additional input capacitance may be needed on the input to reduce voltage overshoot from exceeding the absolute maximum voltage of the device during heavy transient conditions. This is especially important during bench testing when long inductive cables are used to connect the evaluation board to the bench power-supply.

Placing a high value electrolytic capacitor on the output pin is recommended when large transient currents are expected on the output.

## PCB Layout Consideration

The AW35111S/AW35113S is low ON-Resistance load switch, to obtain the optimal performance, PCB layout should be considered carefully. Here are some guidelines:

1. All the peripherals should be placed as close to the device as possible. Place the input capacitor  $C_{IN}$  on the top layer (same layer as the AW35111S/AW35113S) and close to IN pin, and place the output capacitor  $C_{OUT}$  on the top layer (same layer as the AW35111S/AW35113S) and close to OUT pin.
2. The AW35111S/AW35113S integrates an up to 1.5A rated PMOS FET, and the PCB design rules must be respected to properly evacuate the heat out of the silicon. By increasing PCB area, especially around IN and OUT pins, the  $R_{\theta JA}$  of the package can be decreased, allowing higher power dissipation. Blue bold paths in Figure 20 are power lines that will flow large current, please route them on PCB as straight, wide and short as possible.
3. Use rounded corners on the power trace from the power supply connector to AW35111S/AW35113S to decrease EMI coupling.

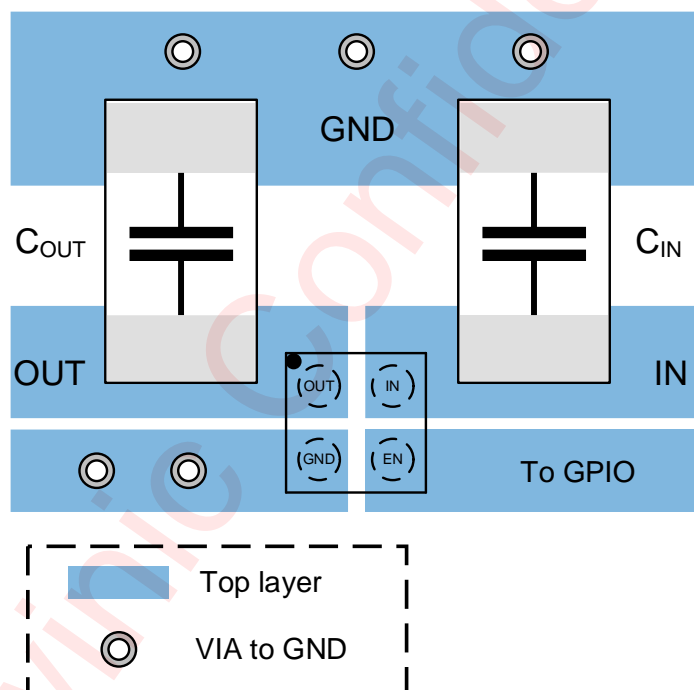
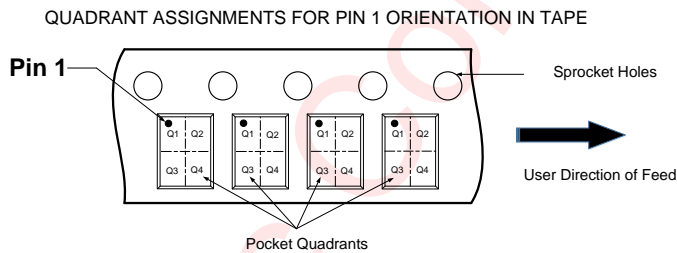
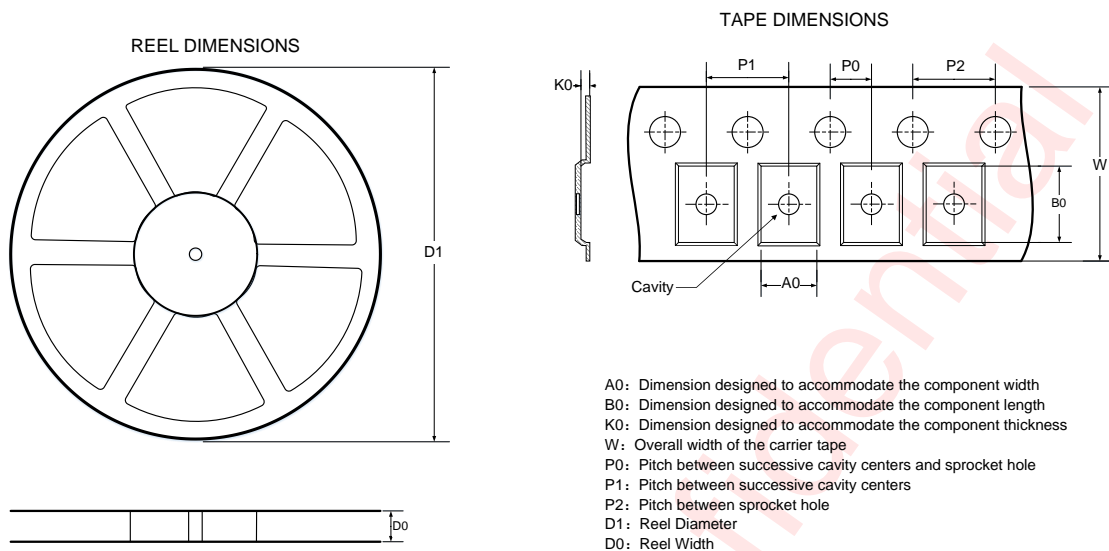

Figure 20 PCB layout example

## Tape And Reel Information

WLCSP 0.618mm\*0.618mm-4B



Note: The above picture is for reference only. Please refer to the value in the table below for the actual size

DIMENSIONS AND PIN1 ORIENTATION

D1 (mm)	D0 (mm)	A0 (mm)	B0 (mm)	K0 (mm)	P0 (mm)	P1 (mm)	P2 (mm)	W (mm)	Pin1 Quadrant
180.0	8.6	0.71	0.71	0.52	2.00	4.00	4.00	8.00	Q1

All dimensions are nominal

## Package Description

WLCSP 0.618mm\*0.618mm-4B

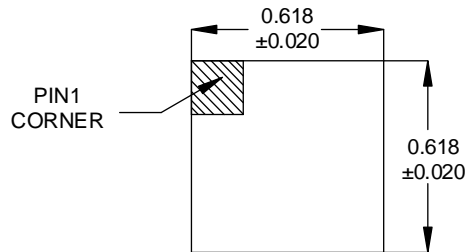

Top View

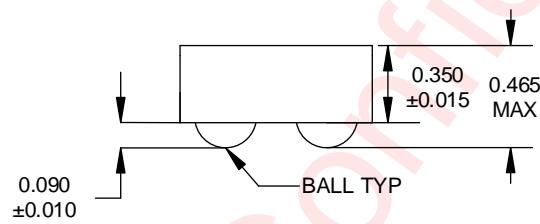

Side View

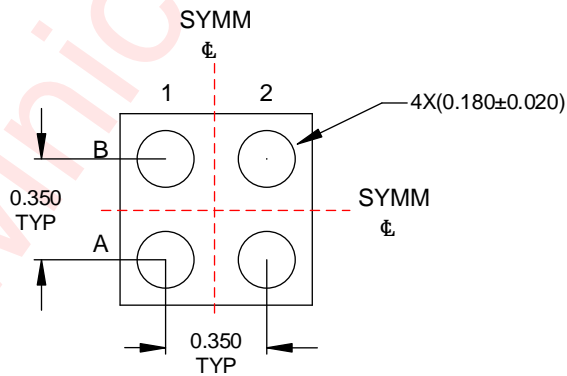

Bottom View

Unit: mm

## Land Pattern Data

WLCSP 0.618mm\*0.618mm-4B

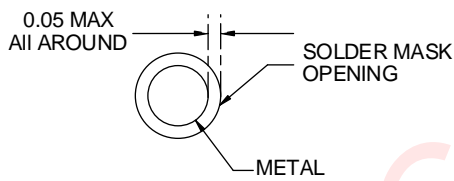
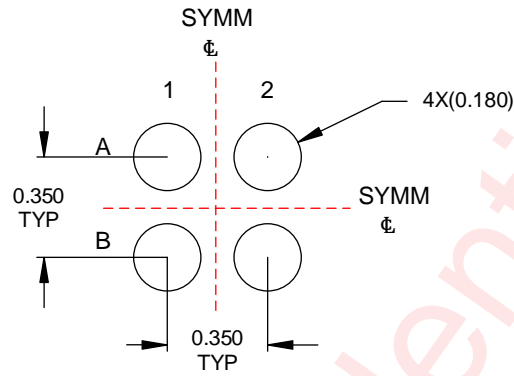

NON-SOLDER MASK DEFINED

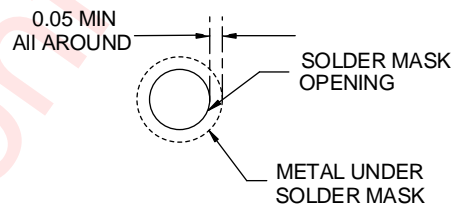

SOLDER MASK DEFINED

Unit: mm

## Revision History

Version	Date	Change Record
V1.0	Apr. 2025	Officially released
V1.1	Jan. 2026	1.Update the General Description(P1) 2.Update the Functional Block Diagram(P3) 3.Update the I <sub>SD</sub> & I <sub>LEAKEN</sub> (P5) 4.Update the Typical Characteristics(P8)

Awinic Confidential

## Disclaimer

All trademarks are the property of their respective owners. Information in this document is believed to be accurate and reliable. However, Shanghai AWINIC Technology Co., Ltd (AWINIC Technology) does not give any representations or warranties, expressed or implied, as to the accuracy or completeness of such information and shall have no liability for the consequences of use of such information.

AWINIC Technology reserves the right to make changes to information published in this document, including without limitation specifications and product descriptions, at any time and without notice. Customers shall obtain the latest relevant information before placing orders and shall verify that such information is current and complete. This document supersedes and replaces all information supplied prior to the publication hereof.

AWINIC Technology products are not designed, authorized or warranted to be suitable for use in medical, military, aircraft, space or life support equipment, nor in applications where failure or malfunction of an AWINIC Technology product can reasonably be expected to result in personal injury, death or severe property or environmental damage. AWINIC Technology accepts no liability for inclusion and/or use of AWINIC Technology products in such equipment or applications and therefore such inclusion and/or use is at the customer's own risk.

Applications that are described herein for any of these products are for illustrative purposes only. AWINIC Technology makes no representation or warranty that such applications will be suitable for the specified use without further testing or modification.

All products are sold subject to the general terms and conditions of commercial sale supplied at the time of order acknowledgement.

Nothing in this document may be interpreted or construed as an offer to sell products that is open for acceptance or the grant, conveyance or implication of any license under any copyrights, patents or other industrial or intellectual property rights.

Reproduction of AWINIC information in AWINIC data books or data sheets is permissible only if reproduction is without alteration and is accompanied by all associated warranties, conditions, limitations, and notices. AWINIC is not responsible or liable for such altered documentation. Information of third parties may be subject to additional restrictions.

Resale of AWINIC components or services with statements different from or beyond the parameters stated by AWINIC for that component or service voids all express and any implied warranties for the associated AWINIC component or service and is an unfair and deceptive business practice. AWINIC is not responsible or liable for any such statements.