

Oct.1.2021 Copyright 2021 HIROSE ELECTRIC CO., LTD. All Rights Reserved.
 In case of consideration for using Automotive equipment / device which demand high reliability, kindly contact our sales window correspondents.

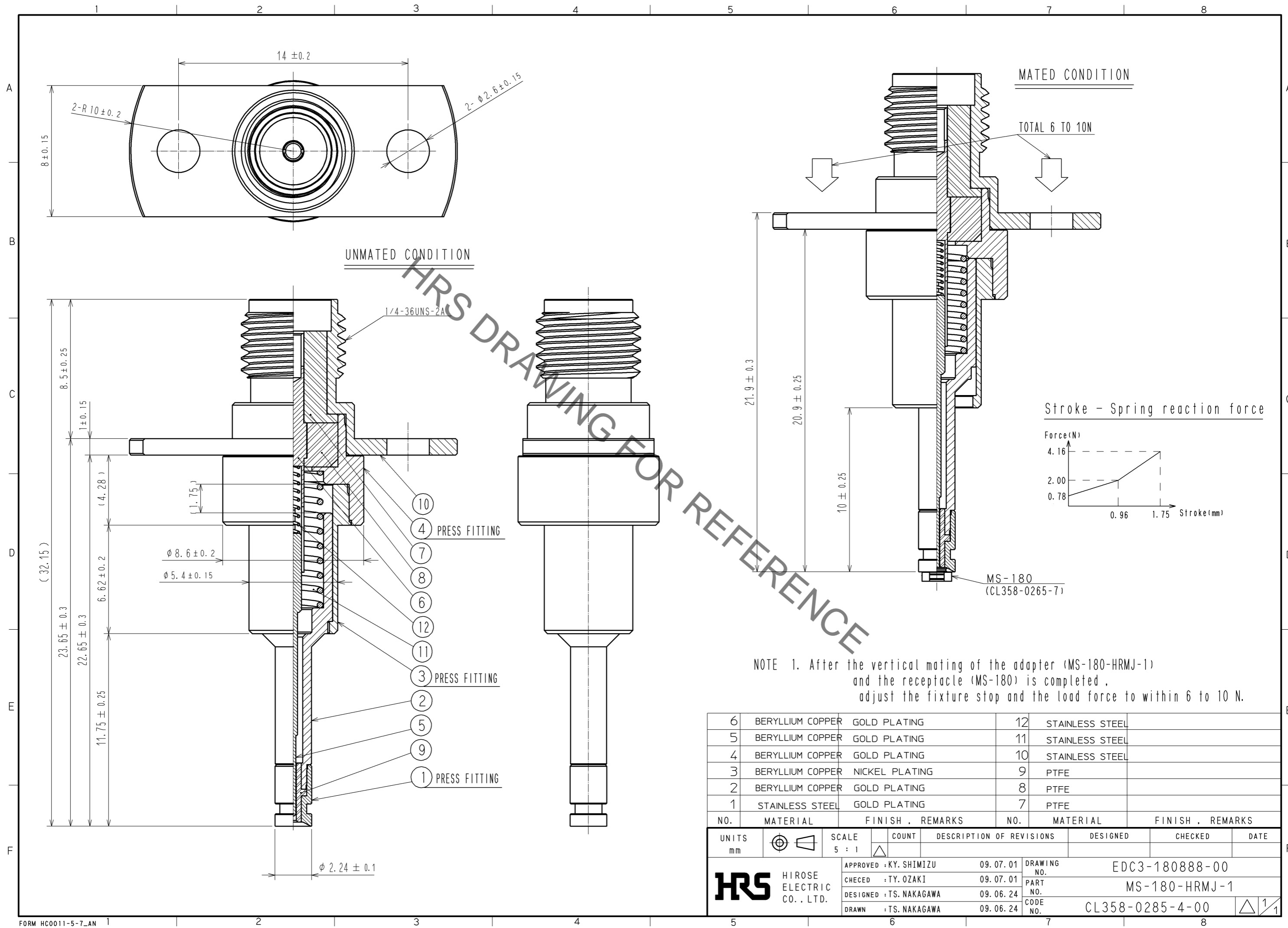

NO.	MATERIAL	FINISH	REMARKS	NO.	MATERIAL	FINISH	REMARKS
6	BERYLLIUM COPPER	GOLD PLATING		12	STAINLESS STEEL		
5	BERYLLIUM COPPER	GOLD PLATING		11	STAINLESS STEEL		
4	BERYLLIUM COPPER	GOLD PLATING		10	STAINLESS STEEL		
3	BERYLLIUM COPPER	NICKEL PLATING		9	PTFE		
2	BERYLLIUM COPPER	GOLD PLATING		8	PTFE		
1	STAINLESS STEEL	GOLD PLATING		7	PTFE		

UNITS	SCALE	COUNT	DESCRIPTION OF REVISIONS	DESIGNED	CHECKED	DATE
mm	5 : 1	△				
APPROVED : KY. SHIMIZU			09.07.01	DRAWING NO. EDC3-180888-00		
CHECKED : TY. OZAKI			09.07.01	PART NO. MS-180-HRMJ-1		
DESIGNED : TS. NAKAGAWA			09.06.24	CODE NO. CL358-0285-4-00		
DRAWN : TS. NAKAGAWA			09.06.24	1/1		