

## Low Noise, RRIO CMOS Op-amps with 10MHz Bandwidth

### Features

- Wide Supply Voltage Range: 1.8V ~ 5.5V
- Low Input Offset Voltage:  $\pm 0.4\text{mV}$
- Slew Rate:  $13\text{V}/\mu\text{s}$
- Low Input Bias Current:  $1\text{pA}$
- Low Broadband Noise:  $13\text{nV}/\sqrt{\text{Hz}}$
- Low Quiescent Current:  $850\mu\text{A}/\text{CH}$
- Rail-to-Rail Input and Output
- Bandwidth: 10MHz
- Sink and Source Current Capability:  $50\text{mA}$

### Applications

- Smart Phones, Tablet PCs
- Consumer Audio-video Equipment
- Headsets/Headphones/Earbuds
- Motion Detectors/Smoke Detectors
- Active Filters
- Low-Side Current Sensing
- Pressure Transmitter
- Process Analytics(Gas, Force, Humidity & PH)

### General Description

The AWS7906X is a high precision, low-power, low-voltage (1.8V to 5.5V) operational amplifiers with rail-to-rail input and output swing capabilities, which makes it ideal to general-purpose applications. This op amp features very good AC performance with a gain-bandwidth product of 10MHz, slew rate of  $13\text{V}/\mu\text{s}$  and low input voltage noise of  $3.8\mu\text{Vpp}$ , while drawing  $850\mu\text{A}$  per channel (typical) quiescent current. It has an input common-mode voltage range that extends to each supply rail, and its outputs swing to within  $27\text{mV}$  of the supply rails with a  $2\text{k}\Omega$  load.

The AWS7906X provides an appropriate solution for space-constrained applications such as battery powered IoT devices, wearable electronics, and personal electronics where minimum PCB footprint is required.

### Device Information

PART NUMBER	PACKAGE	BODY SIZE (NOM)
AWS79061STR	SOT23 - 5L	1.626mm × 2.926mm
AWS79062MPR	MSOP - 8L	3mm × 3mm
AWS79062SPR	SOP - 8L	3.9mm × 4.9mm
AWS79064SPR	SOP - 14L	3.9mm × 8.65mm
AWS79064SPRT	TSSOP - 14L	4.4mm × 5mm

### Typical Application Circuit

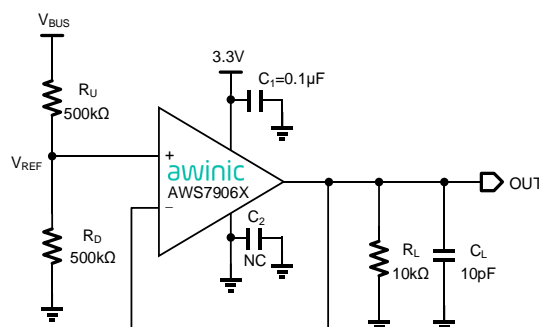
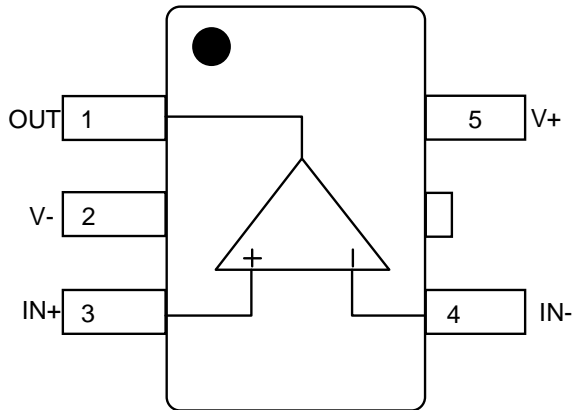

Figure 1 Typical Application of AWS7906X

**Pin Configuration And Top Mark**

SOT23 - 5L

**AWS79061STR**  
(Top View)



**AWS79061STR**  
Marking  
(Top View)

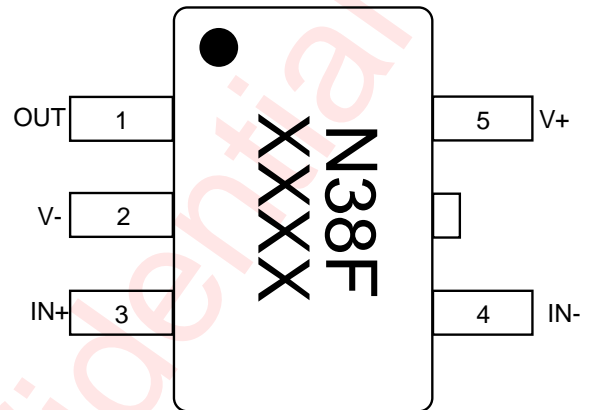

N38F - AWS79061STR  
XXXX - Production Tracing Code

MSOP - 8L

**AWS79062MPR**  
(Top View)

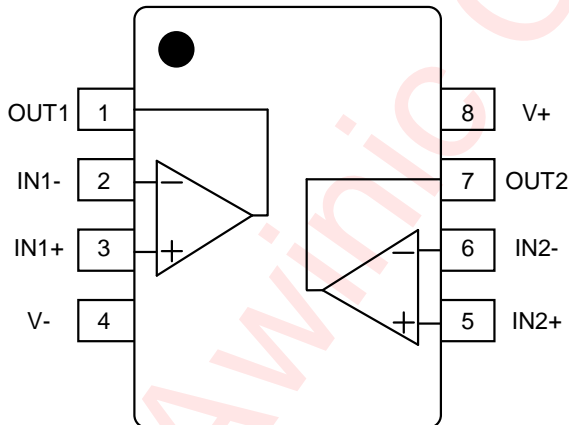

**AWS79062MPR**  
Marking  
(Top View)

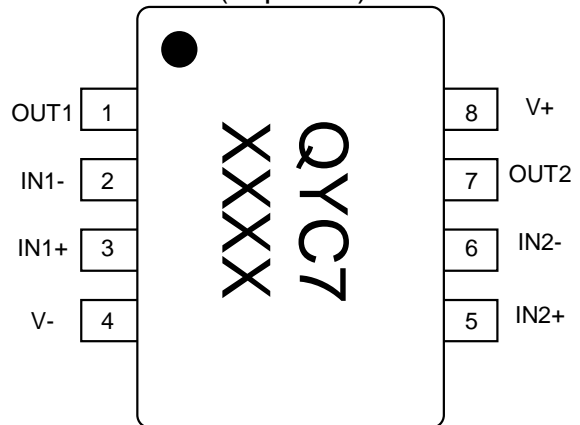

QYC7 - AWS79062MPR  
XXXX - Production Tracing Code

SOP - 8L

**AWS79062SPR**  
(Top View)

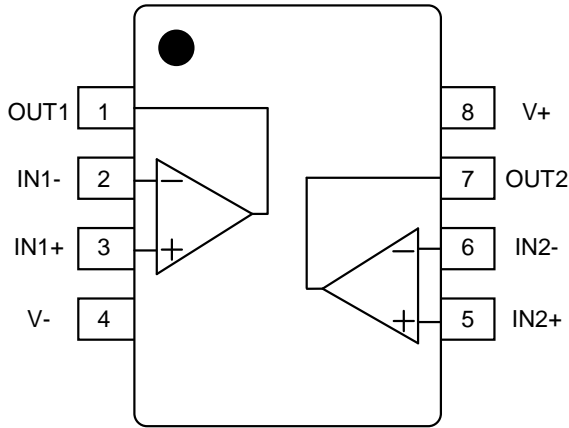

**AWS79062SPR**  
Marking  
(Top View)

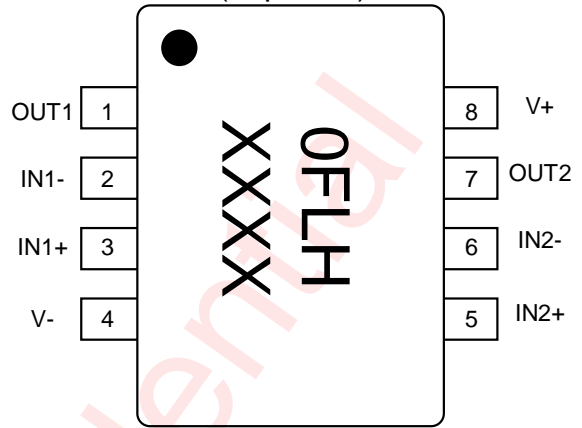

0FLH - AWS79062SPR  
XXXX - Production Tracing Code

SOP - 14L

**AWS79064SPR**  
(Top View)

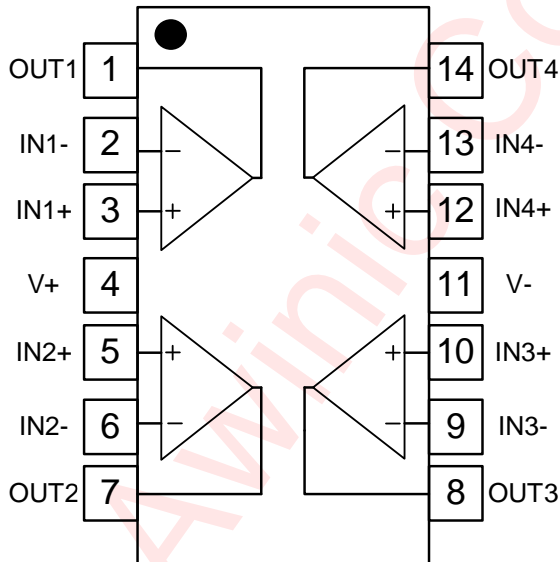

**AWS79064SPR**  
Marking  
(Top View)

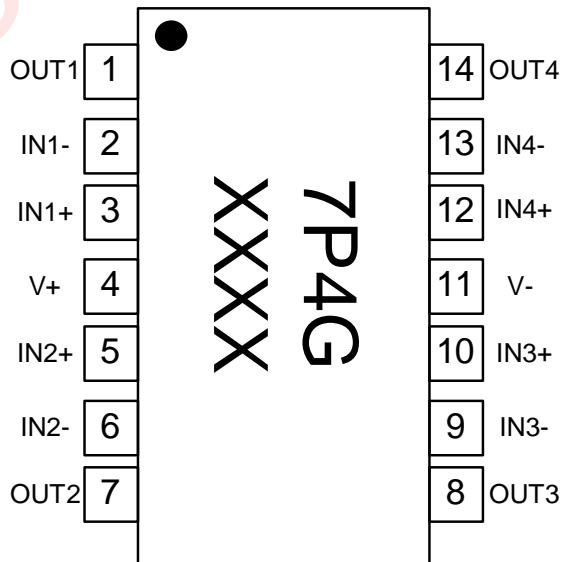

7P4G-AWS79064SPR  
XXXX-Production Tracing Code

TSSOP - 14L

**AWS79064SPRT  
(Top View)**

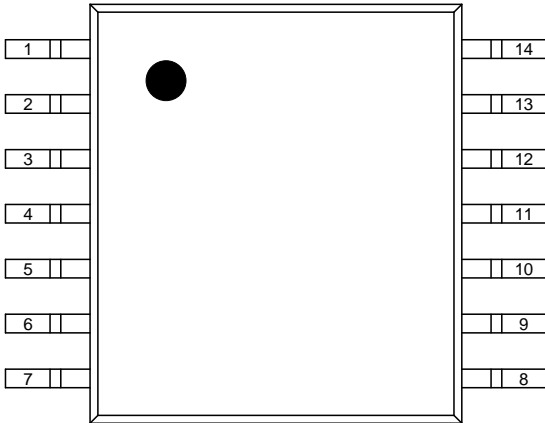

**AWS79064SPRT Marking  
(Top View)**

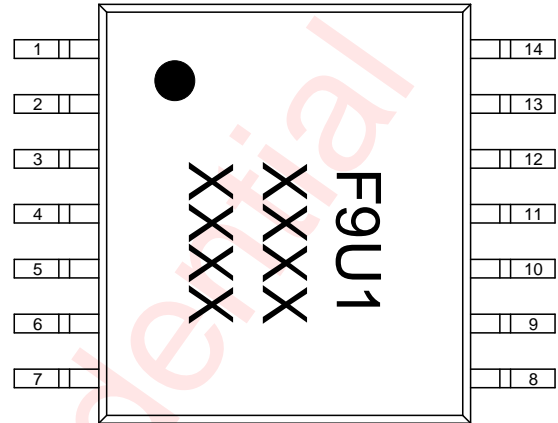

F9U1 - AWS79064SPRT  
XXXX/XXXX - Production Tracing Code

**Figure 2 Pin Configuration**

## Pin Definition

PIN		DESCRIPTION
NAME	SOT23 – 5L	
OUT	1	Output
V-	2	Negative (low) supply or ground (for single-supply operation)
IN+	3	Noninverting input
IN-	4	Inverting input
V+	5	Positive (high) supply

PIN			DESCRIPTION
NAME	MSOP – 8L	SOP – 8L	
OUT1	1	1	Channel 1 output
IN1-	2	2	Channel 1 inverting input
IN1+	3	3	Channel 1 noninverting input
V-	4	4	Negative (low) supply or ground (for single-supply operation)
IN2+	5	5	Channel 2 noninverting input
IN2-	6	6	Channel 2 inverting input
OUT2	7	7	Channel 2 output
V+	8	8	Positive (high) supply

PIN			DESCRIPTION
NAME	SOP – 14L	TSSOP – 14L	
OUT1	1	1	Channel 1 output
IN1-	2	2	Channel 1 inverting input
IN1+	3	3	Channel 1 noninverting input
V+	4	4	Positive (high) supply
IN2+	5	5	Channel 2 noninverting input
IN2-	6	6	Channel 2 inverting input
OUT2	7	7	Channel 2 output
OUT3	8	8	Channel 3 output
IN3-	9	9	Channel 3 inverting input
IN3+	10	10	Channel 3 noninverting input
V-	11	11	Negative (low) supply or ground (for single-supply operation)
IN4+	12	12	Channel 4 noninverting input
IN4-	13	13	Channel 4 inverting input
OUT4	14	14	Channel 4 output

## Functional Block Diagram

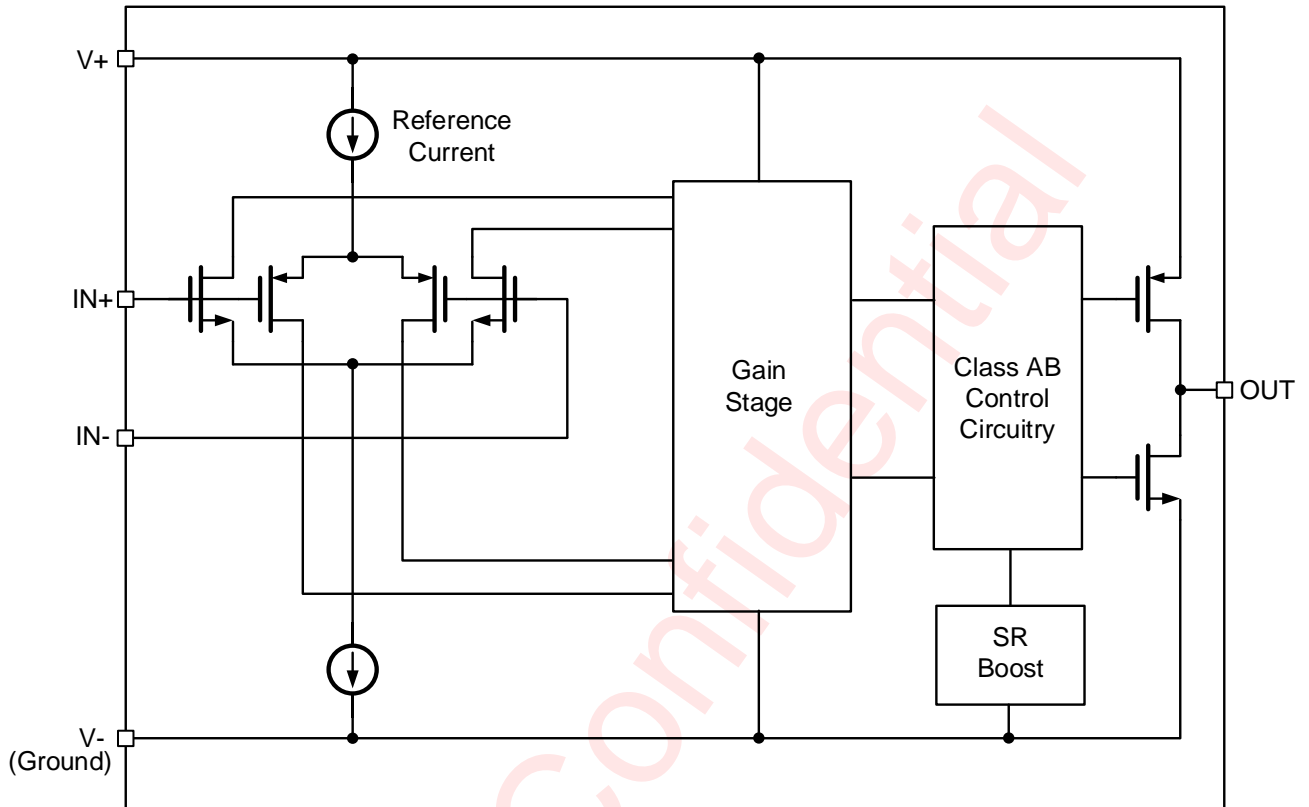

Figure 3 Functional Block Diagram

## Typical Application Circuits

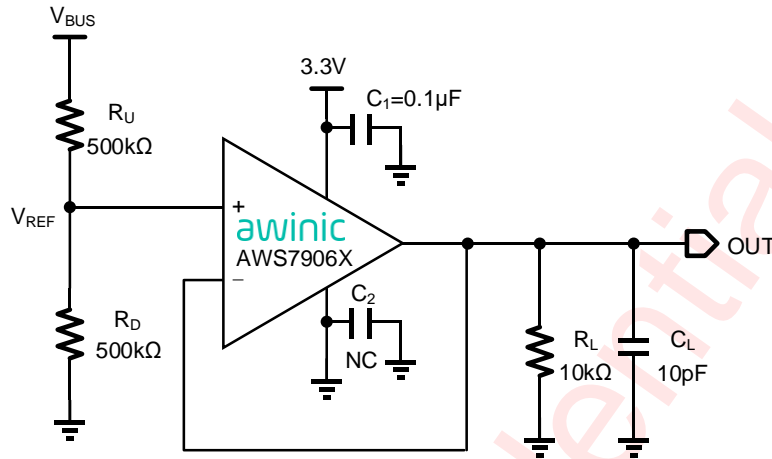

Figure 4 AWS7906X Application Circuit

### Notice for typical application circuits:

1. Bypass capacitors  $C_1/C_2$  are used to reduce the coupled noise by providing a low-impedance path to ground. So low-ESR,  $0.1\mu\text{F}$  ceramic bypass capacitors are necessary between each supply pin and ground, placed close to the device, but far away from input traces. If negative supply is connected to GND, then negative supply to GND can be disconnected to bypass ceramic.

## Ordering Information

Part Number	Temperature	Package	Marking	Moisture Sensitivity Level	Environmental Information	Delivery Form
AWS79061STR	-40°C ~ 125°C	SOT23 - 5L	N38F	MSL3	RoHS+HF	3000 units/ Tape and Reel
AWS79062MPR	-40°C ~ 125°C	MSOP - 8L	QYC7	MSL3	RoHS+HF	3000 units/ Tape and Reel
AWS79062SPR	-40°C ~ 125°C	SOP - 8L	0FLH	MSL3	RoHS+HF	3000 units/ Tape and Reel
AWS79064SPR	-40°C ~ 125°C	SOP - 14L	7P4G	MSL3	RoHS+HF	2500 units/ Tape and Reel
AWS79064SPRT	-40°C ~ 125°C	TSSOP - 14L	F9U1	MSL3	RoHS+HF	3000 units/ Tape and Reel

## Absolute Maximum Ratings (NOTE1)

PARAMETERS		RANGE
Supply voltage, $V_S = (V+) - (V-)$		-0.3V to 6.0V
Signal input pins	Common-mode voltage (NOTE 2)	(V-) - 0.5V to (V+) + 0.5V
	Differential voltage (NOTE 2)	-6.0V to 6.0V
	Current (NOTE 2)	-10mA to 10mA
Output short-circuit (NOTE 3)		Continuous
Operating free-air temperature range $T_A$		-40°C to 125°C
Maximum operating junction temperature $T_{JMAX}$		150°C
Storage temperature $T_{STG}$		-65°C to 150°C
Lead temperature (soldering 10 seconds)		260°C

NOTE1: Conditions out of those ranges listed in "absolute maximum ratings" may cause permanent damages to the device. In spite of the limits above, functional operation conditions of the device should be within the ranges listed in "recommended operating conditions". Exposure to absolute-maximum-rated conditions for prolonged periods may affect device reliability.

NOTE2: Input pins are diode-clamped to each power supply. Input signals that may extend more than 0.5V beyond the supply rails must be current limited to 10mA or less.

NOTE3: A heat sink may be required to keep the junction temperature below the absolute maximum.

## ESD Rating and Latch Up

PARAMETERS	VALUE	UNIT
HBM (Human Body Model) (NOTE 4)	±4	kV
CDM (NOTE 5)	±1.5	kV
Latch-Up (NOTE 6)	+IT: 400 -IT: -400	mA

NOTE4: The human body model is a 100pF capacitor discharged through a 1.5kΩ resistor into each pin. Test method: ESDA/JEDEC JS-001-2023/2024

NOTE5: Test method: ESDA/JEDEC JS-002-2022/2025

NOTE6: Test method: JESD78F/.02

## Thermal Information

THERMAL METRICS		AWS7906X					UNIT
		SOT23	MSOP	SOP	SOP	TSSOP	
SYMBOL	PARAMETER	5 PINS	8 PINS	8 PINS	14 PINS	14 PINS	
$R_{\theta JA}$	Junction-to-ambient thermal resistance	208.9	199.8	149.5	67.2	131.76	°C/W
$R_{\theta JB}$	Junction-to-board thermal resistance	103.8	166.7	98.1	37.8	90.16	°C/W
$R_{\theta JC}$	Junction-to-case (top) thermal resistance	174.7	114.8	99	34.8	51.92	°C/W
$\Psi_{JT}$	Junction-to-top characterization parameter	79.4	31.5	36.4	10.1	3.4	°C/W
$\Psi_{JB}$	Junction-to-board characterization parameter	93.8	134.7	97.3	37.7	88.52	°C/W

## Electrical Characteristics

Unless otherwise noted,  $V_S = (V+) - (V-) = 1.8V$  to  $5.5V$  ( $\pm 0.9V$  to  $\pm 2.75V$ ),  $R_L = 10k\Omega$  connected to  $V_S/2$ ,  $V_{CM} = V_S/2$ , and  $V_{OUT} = V_S/2$ , typical values are at  $V_S = 5V$  and  $T_A = 25^\circ C$ .

SYMBOL	PARAMETER	TEST CONDITION	MIN	TYP	MAX	UNIT
<b>OFFSET VOLTAGE</b>						
$V_{OS}$	Input offset voltage	$V_S = 5V$	-1.6	$\pm 0.4$	1.6	mV
$dV_{OS}/dT$	Input offset voltage drift	$T_A = -40^\circ C$ to $125^\circ C$		$\pm 0.5$		$\mu V/^\circ C$
PSRR	Power-supply rejection ratio	$V_S = 1.8V$ to $5.5V$ , $V_{CM} = V_-$	70	97		dB
$C_S$	Multiple amplifier channel separation	DC		110		dB
<b>INPUT BIAS CURRENT</b>						
$I_B$	Input bias current	$V_{CM} = V_S/2$	-100	$\pm 1$	100	pA
$I_{OS}$	Input offset current		-100	$\pm 1$	100	pA
<b>NOISE</b>						
$E_N$	Input voltage noise (peak-to-peak)	$f = 0.1Hz$ to $10Hz$ , $V_S = 5.5V$		3.8		$\mu V_{PP}$
$e_N$	Input voltage noise density	$f = 1kHz$ , $V_S = 5V$		13		$nV/\sqrt{Hz}$
		$f = 10kHz$ , $V_S = 5V$		9		
<b>INPUT VOLTAGE RANGE</b>						
$V_{CM}$	Common-mode voltage range	No phase reversal, rail-to-rail input	(V-) -0.1		(V+) +0.1	V
CMRR	Common-mode rejection ratio	$(V-) - 0.1V < V_{CM} < (V+) - 1.4V$ , $V_S = 1.8V$	65	93		dB
		$(V-) - 0.1V < V_{CM} < (V+) - 1.4V$ , $V_S = 5.5V$	70	99		
		$(V-) - 0.1V < V_{CM} < (V+) + 0.1V$ , $V_S = 5.5V$	58	84		
		$(V-) - 0.1V < V_{CM} < (V+) + 0.1V$ , $V_S = 1.8V$	55	77		
<b>INPUT CAPACITANCE</b>						
$C_{ID}^{(1)}$	Differential Mode			1		pF
$C_{IC}$	Common Mode			2.5		
<b>POWER SUPPLY</b>						
$V_S$	Specified voltage range		1.8 ( $\pm 0.9$ )		5.5 ( $\pm 2.75$ )	V
$I_Q$	Quiescent current per channel	$V_S = 5.5V$ , $I_O = 0A$	600	850	1200	$\mu A$

SYMBOL	PARAMETER	TEST CONDITION	MIN	TYP	MAX	UNIT
<b>OPEN-LOOP GAIN</b>						
A <sub>OL</sub>	Open-loop voltage gain	V <sub>S</sub> = 5.5V, R <sub>L</sub> = 10kΩ, (V <sub>-</sub> ) + 0.05 V < V <sub>O</sub> < (V <sub>+</sub> ) – 0.05V	80	125		dB
		V <sub>S</sub> = 1.8 V, R <sub>L</sub> = 10kΩ, (V <sub>-</sub> ) + 0.06 V < V <sub>O</sub> < (V <sub>+</sub> ) – 0.06V	60	115		dB
		V <sub>S</sub> = 1.8V, R <sub>L</sub> = 2kΩ, (V <sub>-</sub> ) + 0.1 V < V <sub>O</sub> < (V <sub>+</sub> ) – 0.1V	70	115		dB
		V <sub>S</sub> = 5.5V, R <sub>L</sub> = 2kΩ, (V <sub>-</sub> ) + 0.15 V < V <sub>O</sub> < (V <sub>+</sub> ) – 0.15V	80	130		dB
<b>FREQUENCY RESPONSE CHARACTERISTICS</b>						
GBP	Gain-bandwidth product	V <sub>S</sub> = 5V, G = +1		10		MHz
φ <sub>m</sub>	Phase margin	V <sub>S</sub> = 5V, G = +1		45		°
SR	Slew rate	V <sub>S</sub> = 5V, G = +1	6	13		V/μs
t <sub>s</sub>	Settling time	To 0.1%, V <sub>S</sub> = 5V, V <sub>STEP</sub> = 2V, G = +1, C <sub>L</sub> = 100pF		1.5		μs
THD+N	Total harmonic distortion + noise	V <sub>S</sub> = 5V, V <sub>CM</sub> = 2.5V, V <sub>O</sub> = 0.5V <sub>RMS</sub> , G = +1, f = 1kHz, 80kHz measurement BW		0.0015		%
t <sub>OR</sub>	Overload recovery time	V <sub>S</sub> = 5.5V, V <sub>IN</sub> × gain > V <sub>S</sub>		200		ns
<b>OUTPUT CHARACTERISTICS</b>						
V <sub>OP</sub>	Voltage output swing from positive supply rail	V <sub>S</sub> = 5.5V, R <sub>L</sub> = 10kΩ		5		mV
		V <sub>S</sub> = 5.5V, R <sub>L</sub> = 2kΩ	12	27	40	
V <sub>ON</sub>	Voltage output swing from negative supply rail	V <sub>S</sub> = 5.5V, R <sub>L</sub> = 10kΩ		4		mV
		V <sub>S</sub> = 5.5V, R <sub>L</sub> = 2kΩ	10	20	32	
I <sub>SC</sub>	Short-circuit current per channel	V <sub>S</sub> = 5.5V	30	±54	85	mA
		V <sub>S</sub> = 3.3V	23	±50	75	
		V <sub>S</sub> = 1.8V	5	±13	25	

(1) The values are guaranteed by design.

### Typical Characteristics

At  $T_A = 25^\circ\text{C}$ ,  $V_+ = 2.75\text{V}$ ,  $V_- = -2.75\text{V}$ ,  $V_{CM} = V_S/2$ , and  $V_{OUT} = V_S/2$ ,  $R_L = 10\text{k}\Omega$  connected to  $V_S/2$  unless otherwise noted.

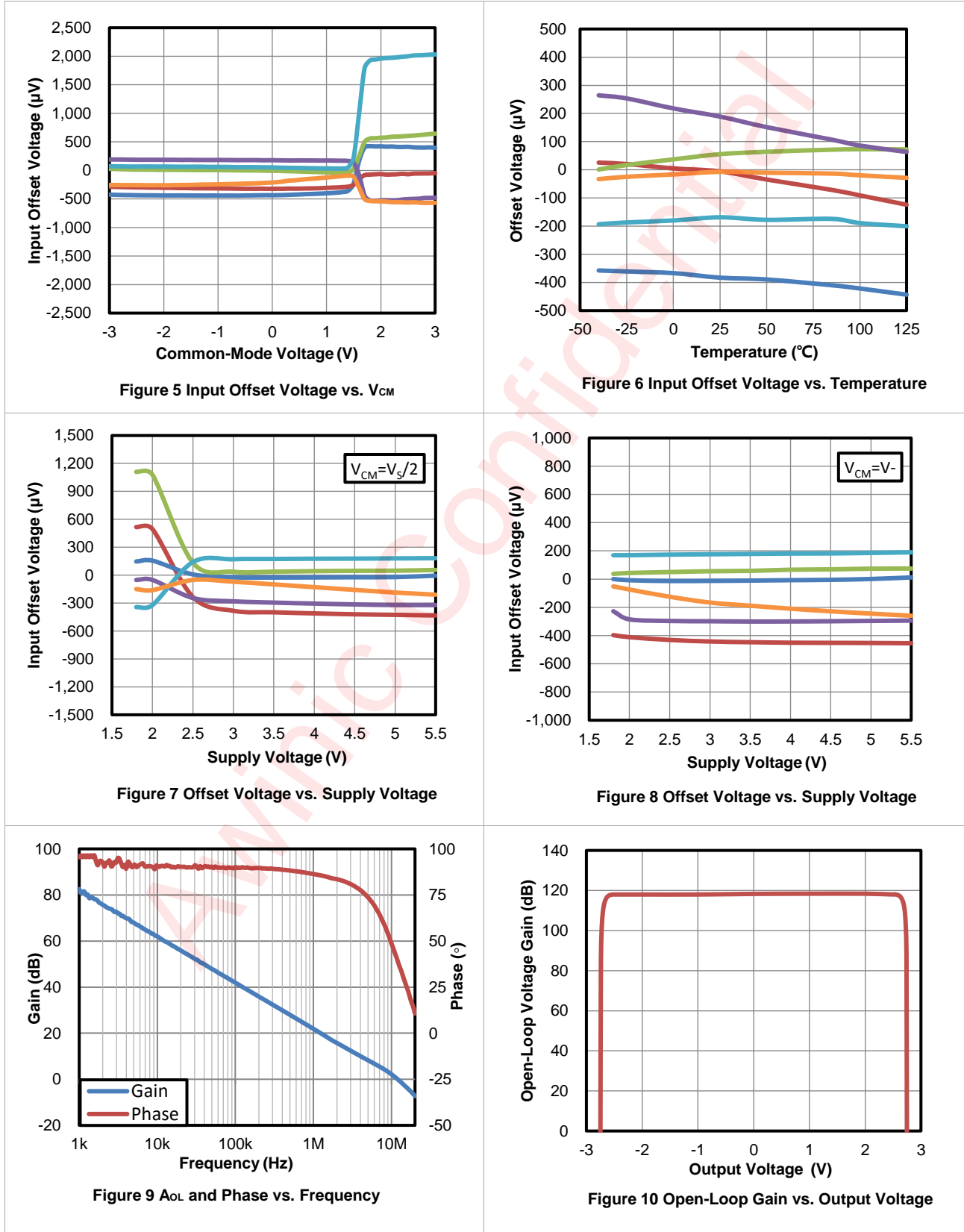

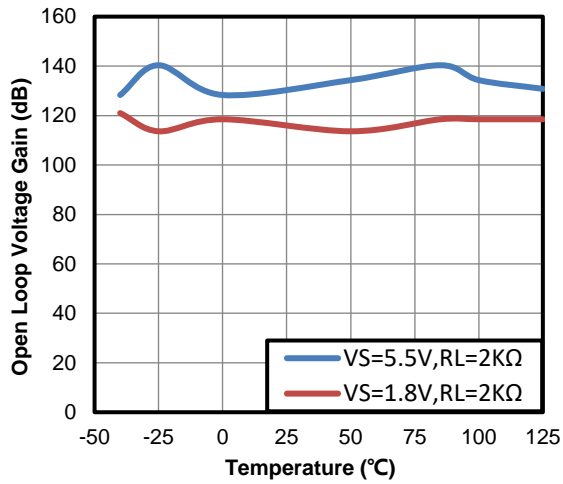

Figure 11 Open Loop Gain vs. Temperature

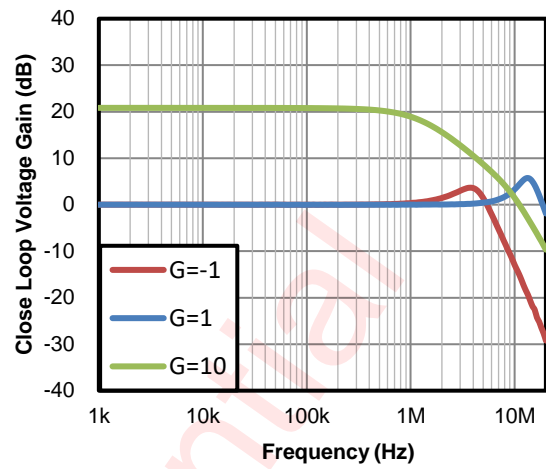

Figure 12 Close Loop Gain vs. Frequency

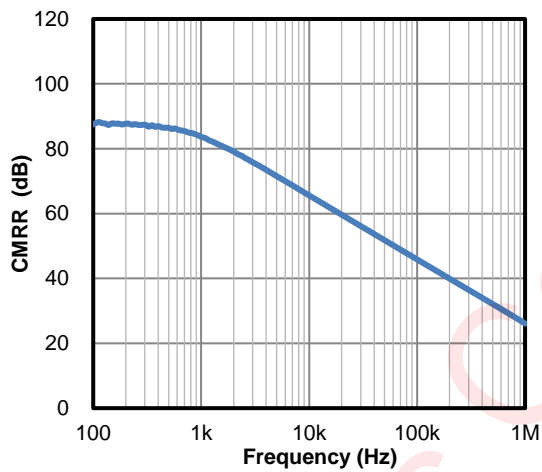

Figure 13 CMRR vs. Frequency

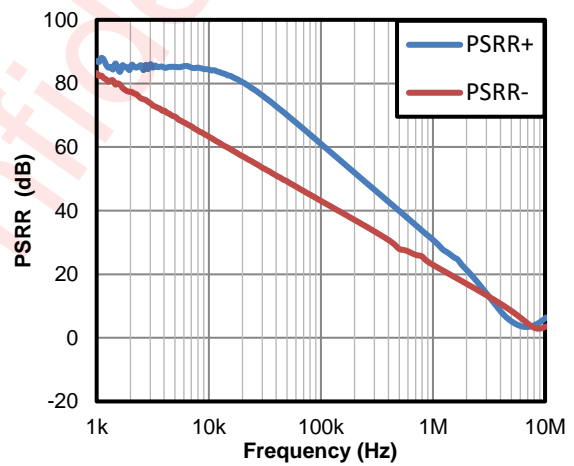

Figure 14 PSRR vs. Frequency

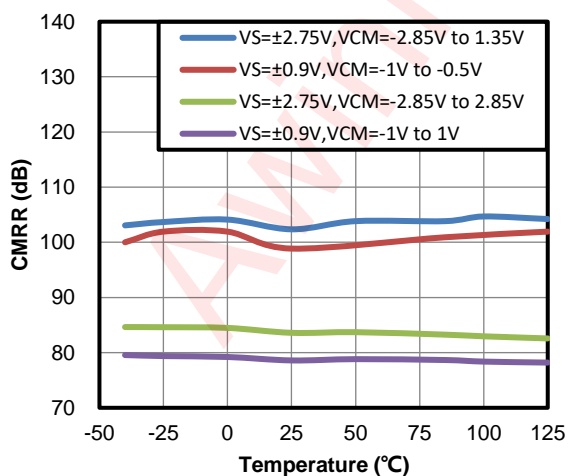

Figure 15 CMRR vs. Temperature

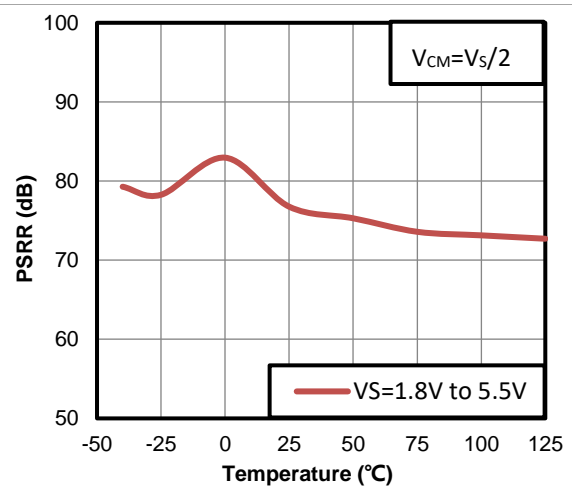

Figure 16 PSRR vs. Temperature

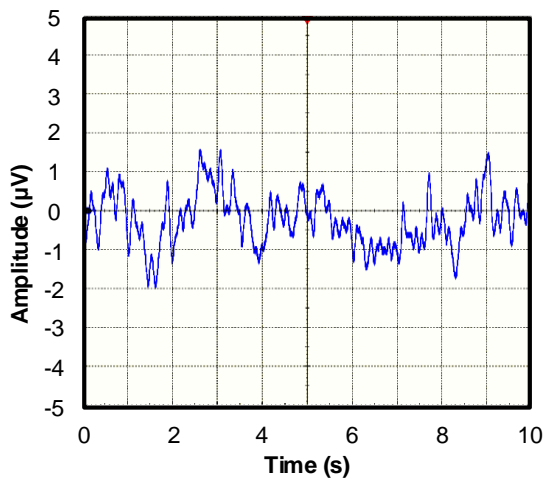

Figure 17 0.1-Hz to 10-Hz Integrated Voltage Noise

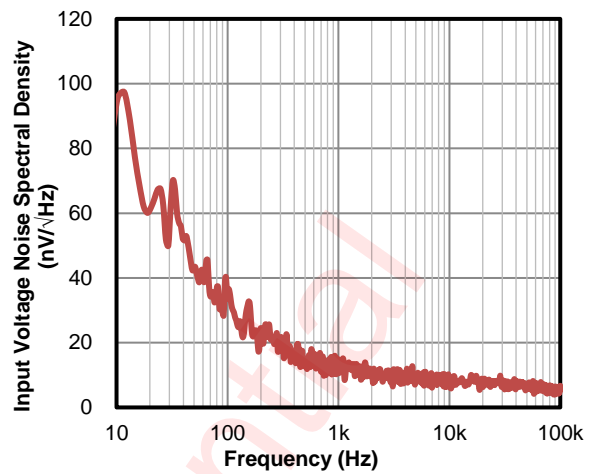

Figure 18 Voltage Noise Spectral Density vs. Frequency

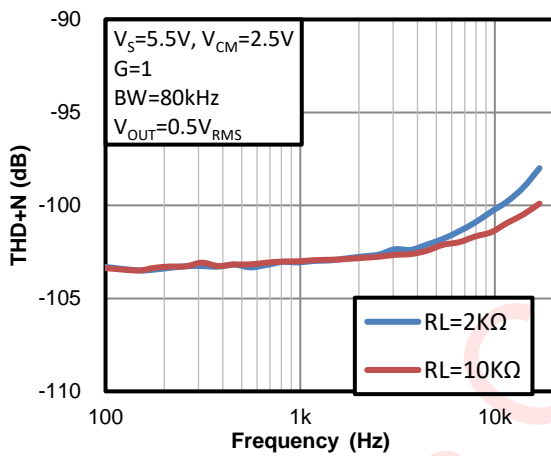

Figure 19 THD + N vs. Frequency

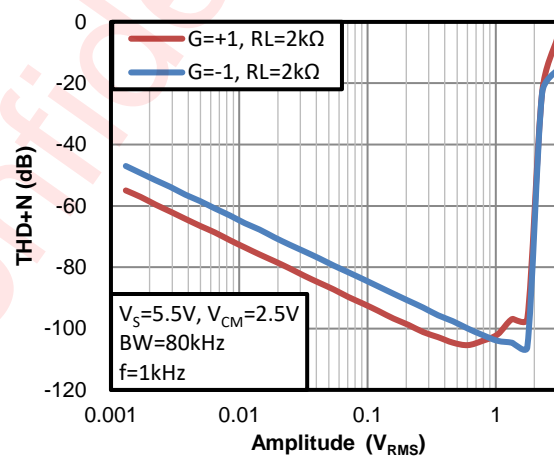

Figure 20 THD + N vs. Amplitude

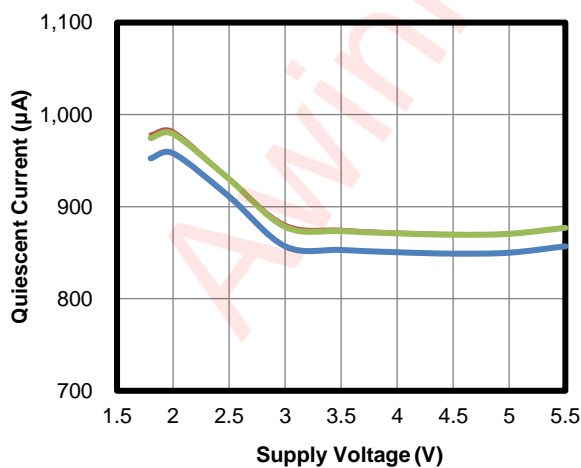

Figure 21 IQ vs. Supply Voltage

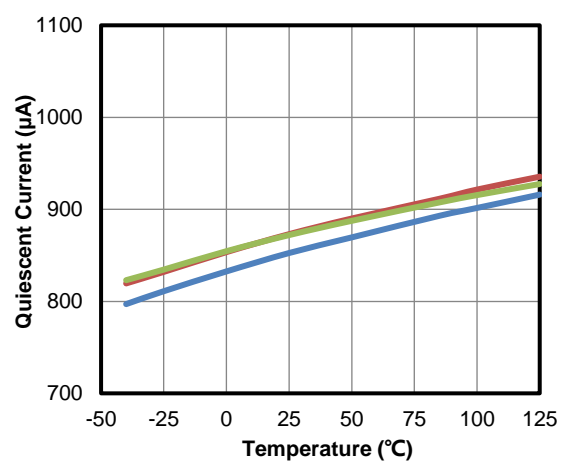

Figure 22 IQ vs. Temperature

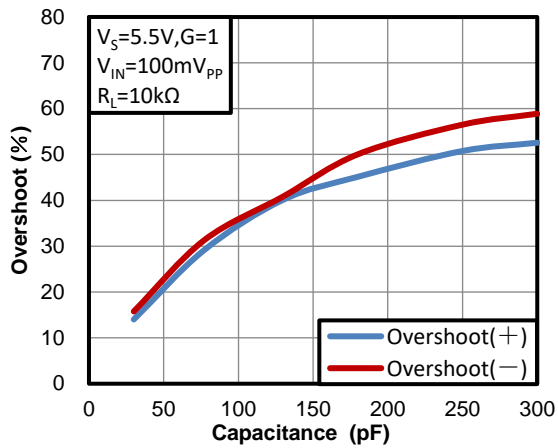

Figure 23 Small Signal Overshoot vs. CL

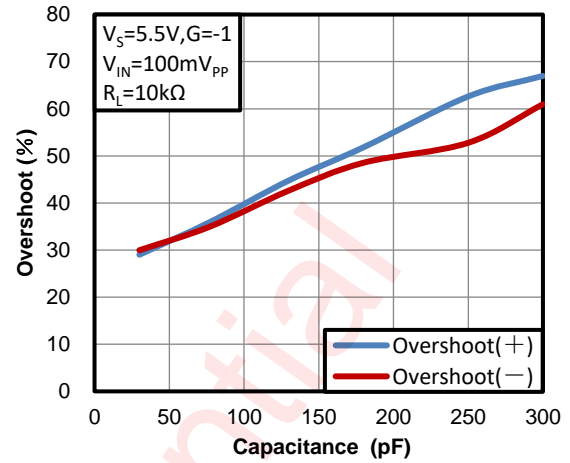

Figure 24 Small Signal Overshoot vs. CL

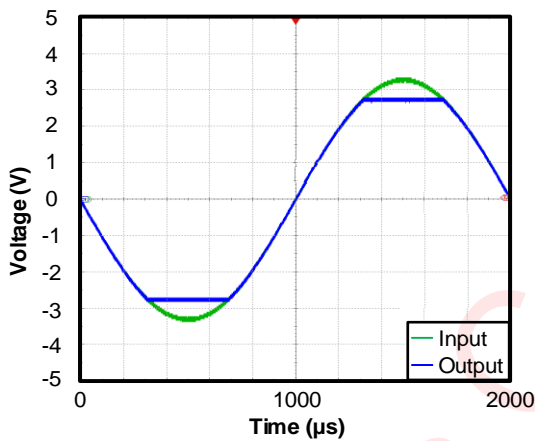

Figure 25 No Phase Reversal

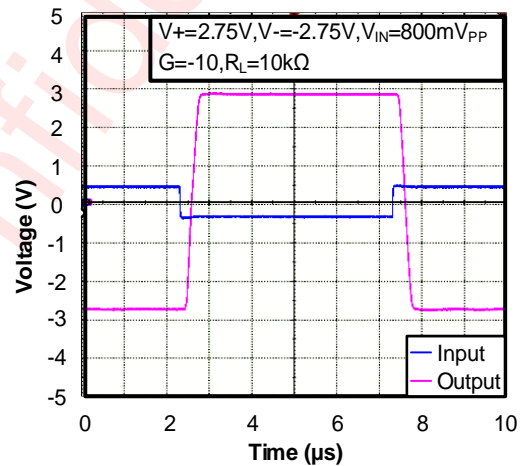

Figure 26 Overload Recovery

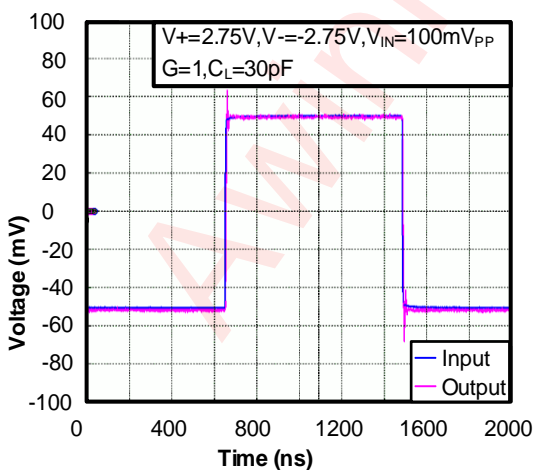

Figure 27 Small Signal Step Response

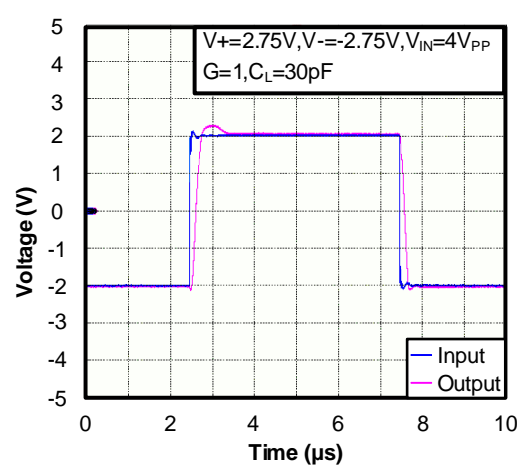

Figure 28 Large Signal Step Response

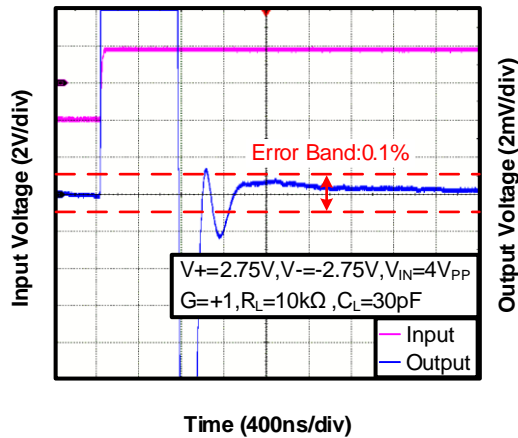

Figure 29 Large Signal Settling Time (Positive)

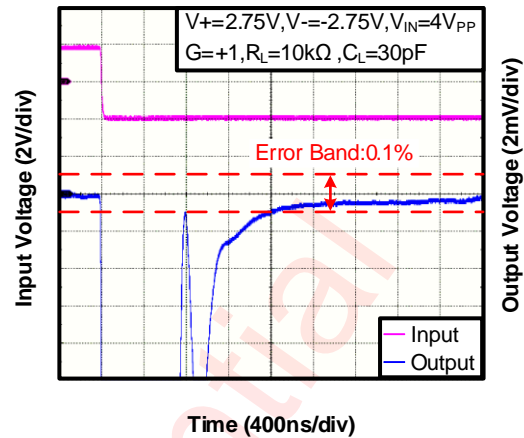

Figure 30 Large Signal Settling Time (Negative)

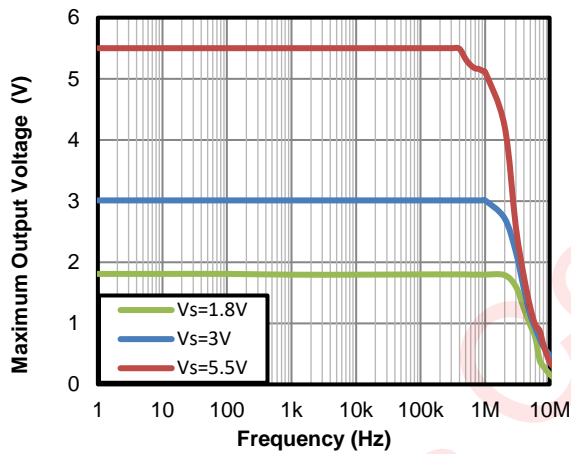

Figure 31  $V_{OUT\_MAX}$  vs. Frequency and  $V_S$

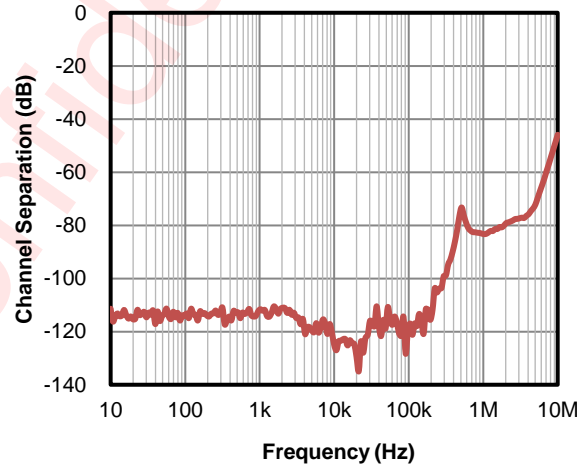

Figure 32 Channel Separation vs. Frequency

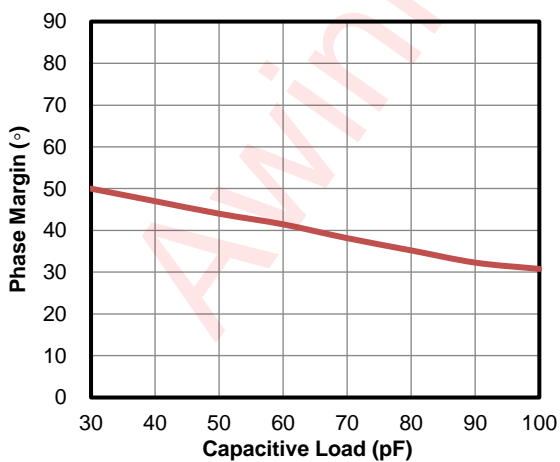

Figure 33 Phase Margin vs. Capacitive Load

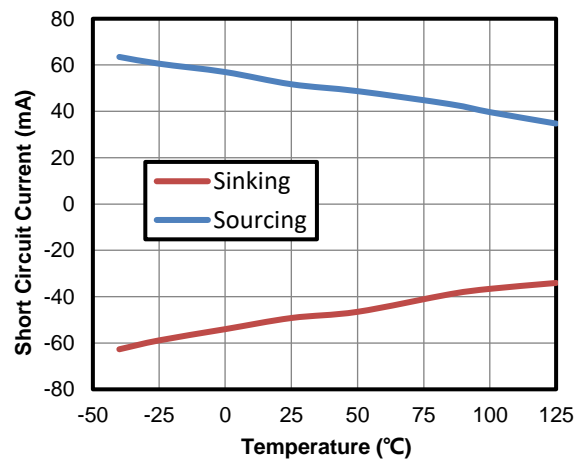

Figure 34 Short Circuit Current vs. Temperature

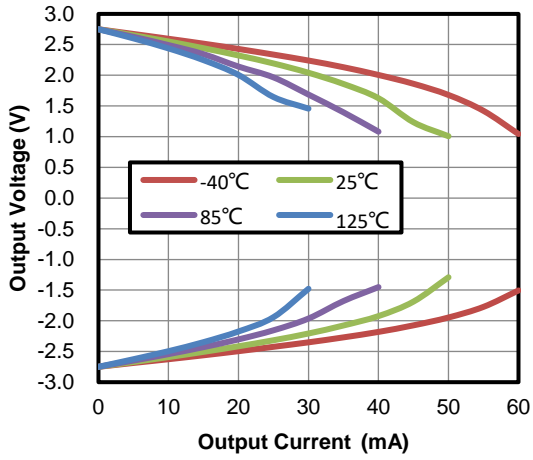

Figure 35 Output Voltage vs. Output Current

Awinic Confidential

## Detailed Functional Description

The AWS7906X is a high precision, low-voltage, low-power operational amplifier with rail-to-rail input and output swing capabilities, while drawing 850 $\mu$ A per channel (typical) quiescent current. The device can be unity-gain stable with power supply voltages from 1.8V to 5.5V, which makes it ideal for a wide range of general-purpose applications.

### **Rail-to-Rail Input**

When the input voltage is close to  $V+$ , op-amps with a differential input pair composed of P-channel MOSFETs do not provide a normal output, because a current source enters the linear region and gain is reduced. Similarly, op-amps with a differential input pair composed of N-channel MOSFETs do not provide a normal output when the input voltage is close to  $V-$ . The input voltage range of the AWS7906X can be as high as  $(V+) + 0.1V$  or as low as  $(V-) - 0.1V$  within the full supply voltage range of 1.8V ( $\pm 0.9V$ ) to 5.5V ( $\pm 2.75V$ ). This performance is achieved by using an N-channel input differential pair in parallel with a P-channel differential pair. When input voltage is close to the positive rail, typically  $(V+) - 1.4V$  to  $(V+) + 0.1V$ , the N-channel pair is active, whereas the P-channel pair is active for inputs from  $(V-) - 0.1V$  to approximately  $(V+) - 1.4V$ . Both of the input pairs are on when the input voltage is between typically  $(V+) - 1.2V$  to  $(V+) - 1V$ , which is usually called the transition region. Within this transition region, PSRR, CMRR, offset voltage, and THD can degrade compared to device operation outside this region. Furthermore, the transition region can range from  $(V+) - 1.4V$  to  $(V+) - 1.2V$  on the low end, and up to  $(V+) - 1V$  to  $(V+) - 0.8V$  on the high end with process variations.

### **Rail-to-Rail Output**

A class-AB output stage with common-source transistors achieves full rail-to-rail output swing capability. Different load conditions change the ability of the amplifier to swing close to the rails. The AWS7906X output stage can drive up to a 2k $\Omega$  load and still swing to within 27mV of the supply rails. The output of the amplifier has reverse-biased ESD diodes connected to each supply. The output should not be forced more than 0.3V beyond either supply, otherwise current will flow through these diodes.

The rail-to-rail output stage of the amplifier can be modeled as a current source when driving the load toward  $V+$ , and as a current sink when driving the load toward  $V-$ . The limit of this current source/sink varies with supply voltage. The maximum output current is a function of total supply voltage. The output current capability increases as the supply voltage to the amplifier increases. Attention must be paid to keep the junction temperature of the op-amp below 150 $^{\circ}$ C when the output is in continuous short-circuit.

### **Phase Reversal Protection**

Many op amps exhibit a phase reversal when the input is driven beyond its specified input common-mode range, causing the output to reverse into the opposite rail. This condition is most often encountered in noninverting circuits. The AWS7906X has internal phase-reversal protection, therefore, input signals beyond the rails do not cause phase reversal. This performance is shown in Figure 36.

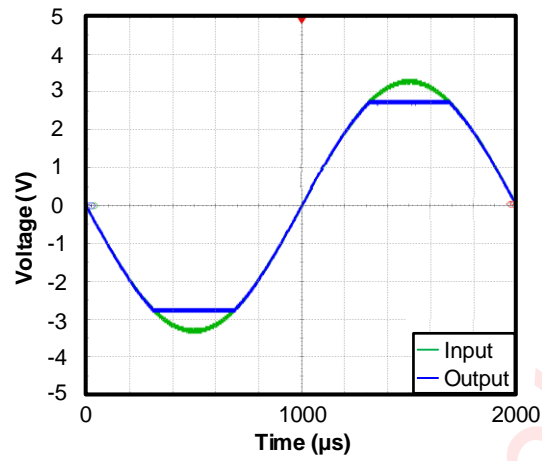

Figure 36 No Phase Reversal

Awinic Confidential

## PCB Layout Consideration

For the optimal performance of the device, good PCB layout practices are needed, here are some guidelines:

1. Bypass capacitors are used to reduce the coupled noise by providing a low-impedance path to ground. So low-ESR, 0.1  $\mu\text{F}$  ceramic bypass capacitors are necessary between each supply pin and ground, placed close to the device, but far away from input traces.
2.  $R_i$  is a balance resistor equals to  $R_G \parallel R_F$  to reduce the influence of the input bias current on  $R_G$  and  $R_F$ , which can be shorted when unnecessary.
3. Separate grounding for analog and digital portions of circuitry for better noise suppression. Devote one or more layers on multilayer PCBs to ground planes, which help distribute heat and reduces EMI noise.
4. Run the input traces far away from the  $V_s$  supply or output traces to reduce the parasitic coupling. If not, cross these sensitive traces at a 90 degree instead of being parallel with the noisy trace.
5. The input traces are the most sensitive part of the circuit, so keep the length of input traces as short as possible. Place the external resistors and capacitors as close to device as possible, especially the  $R_F$  and  $R_G$  should be close to the inverting input to minimize the parasitic capacitance.
6. In differential applications, the trace of the inverting input and the non-inverting input should be symmetrical including the same layer, same length, same width and same line spacing.
7. Any precision integrated circuit may experience performance shifts due to moisture ingress into the plastic package. Following any aqueous PCB cleaning process, baking the PCB assembly is recommended to remove moisture introduced into the device packaging during the cleaning process.

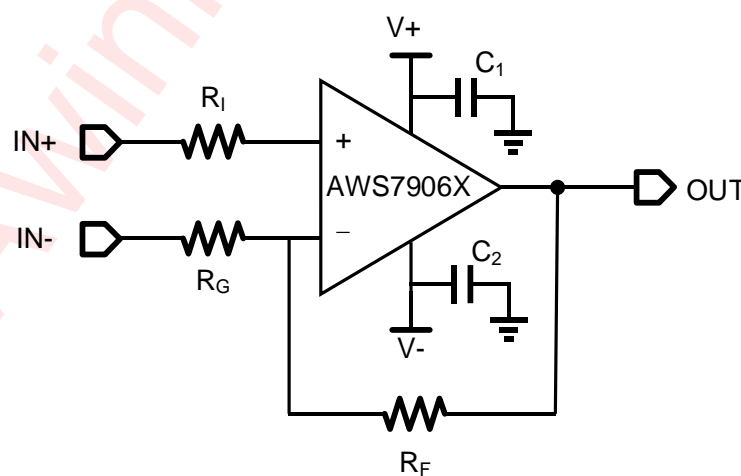
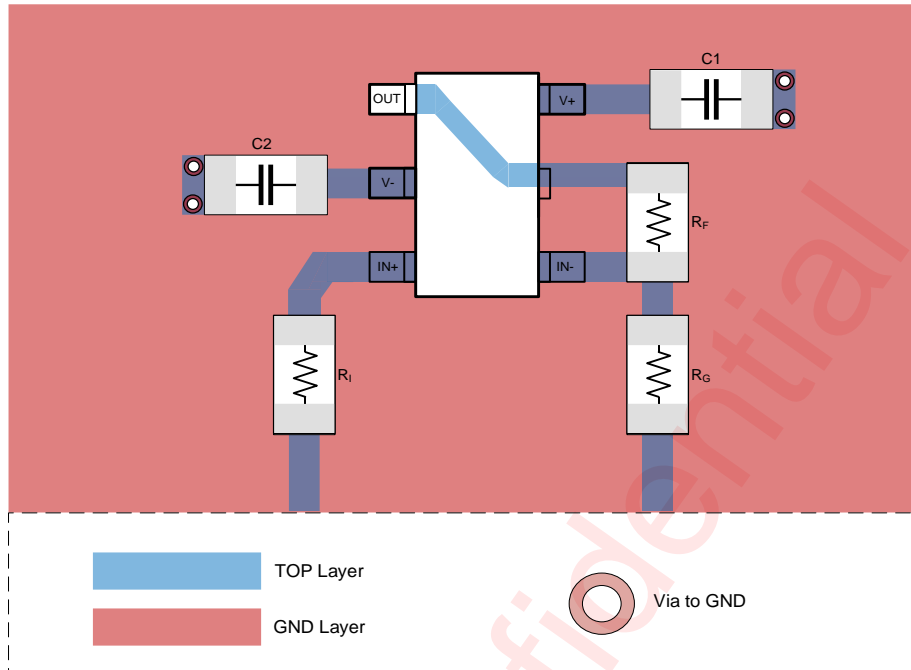
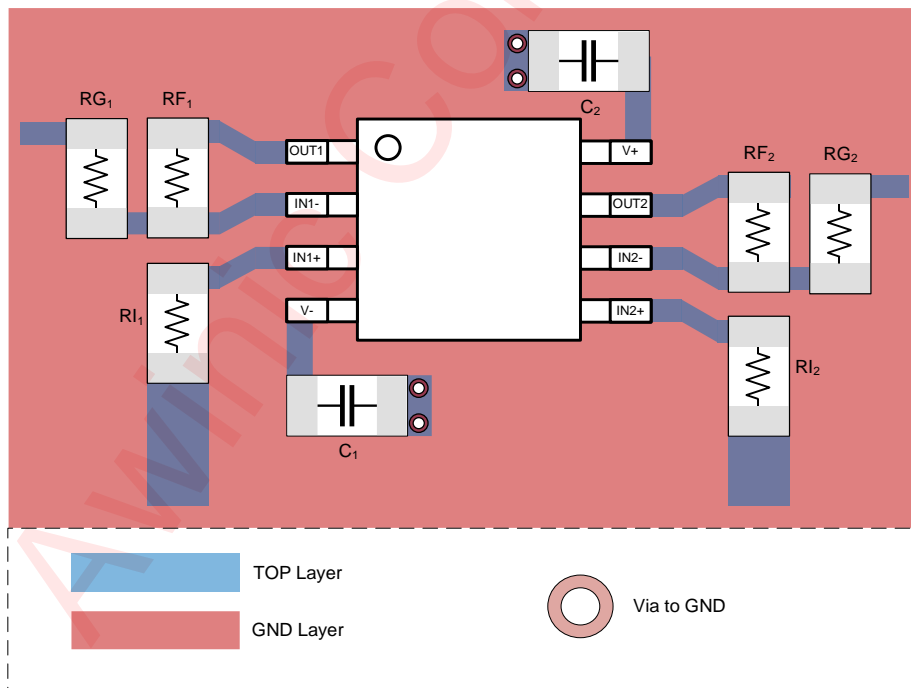

Figure 37 AWS7906X Schematic Example

SOT23 - 5L



MSOP - 8L / SOP - 8L



SOP - 14L

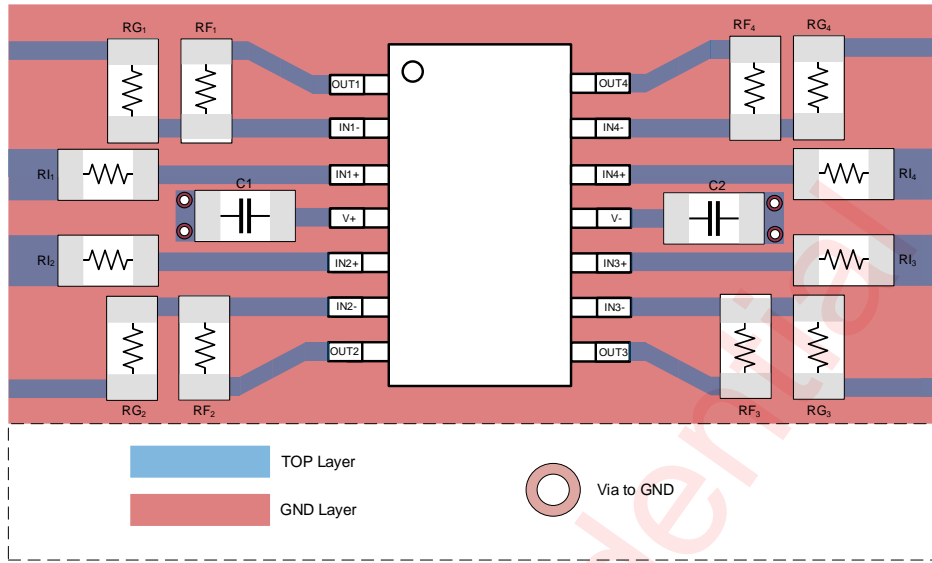

TSSOP - 14L

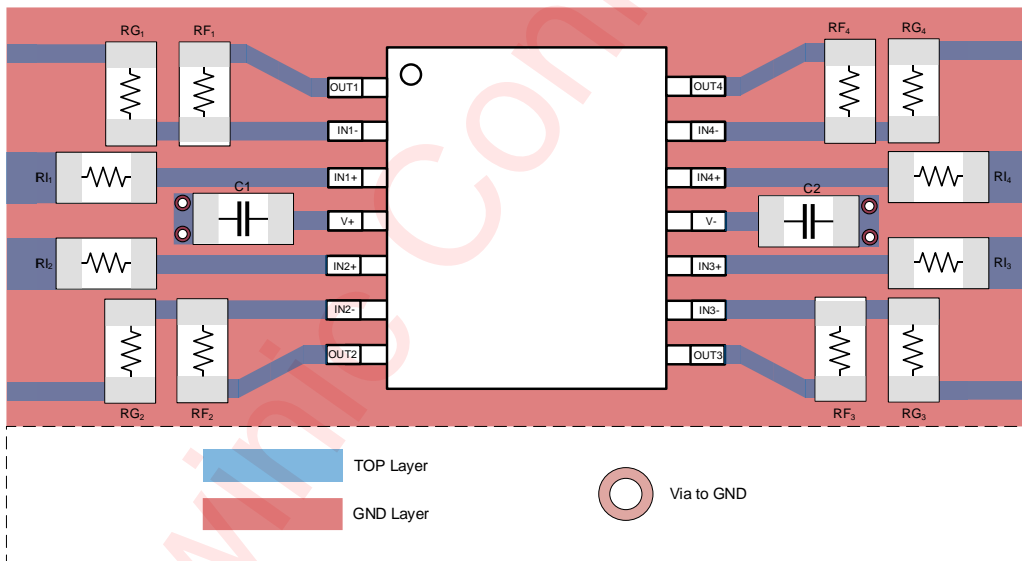

Figure 38 AWS7906X Layout Example

### PCB Surface Leakage Current

In high precision applications where input bias current is critically concerned, the leakage current on PCB surface caused by dust or humidity may badly reduce the output accuracy. In this case, a multi-layer PCB is recommended for routing the input traces under the PCB surface. In addition, the usage of a guard ring can significantly reduce the leakage current to sensitive node. A conductive ring surrounding the inputs should be connected to a low impedance node with the same voltage as the inputs, so this ring will absorb the leakage current from high voltage nodes around the inputs.

For non-inverting gain application, connect the IN+ to the input with traces not touching the PCB surface, for example, routing in second layer in Figure 39. Then surround the IN+ pin with a guard ring which is connected to IN-, thus biasing the guard ring with the same voltage of the common mode input voltage.

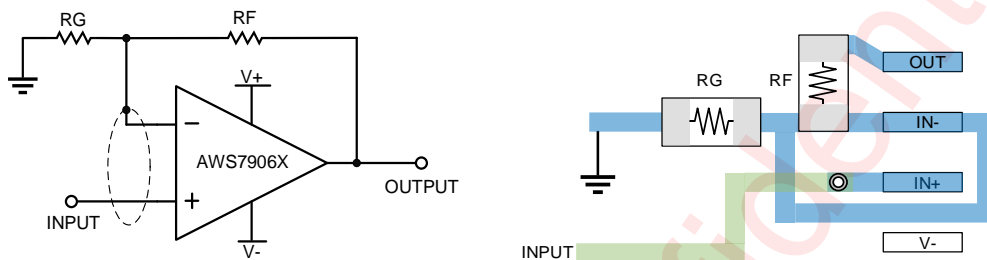

Figure 39 Non-inverting Gain Application Schematic and Layout Example

Similarly, for inverting gain application, connect the IN- to the input with traces not touching the PCB surface, for example, striding over with the input resistor in Figure 40. Then surround the IN- pin with a guard ring which is connected to IN+, thus biasing the guard ring with the reference voltage of AWS7906X.

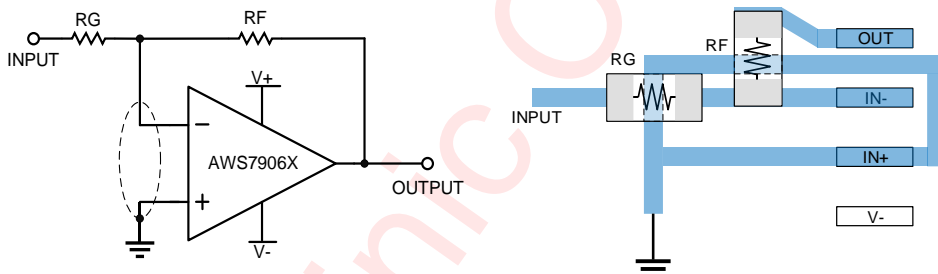
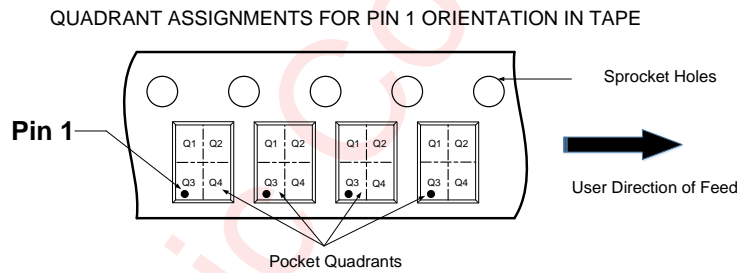
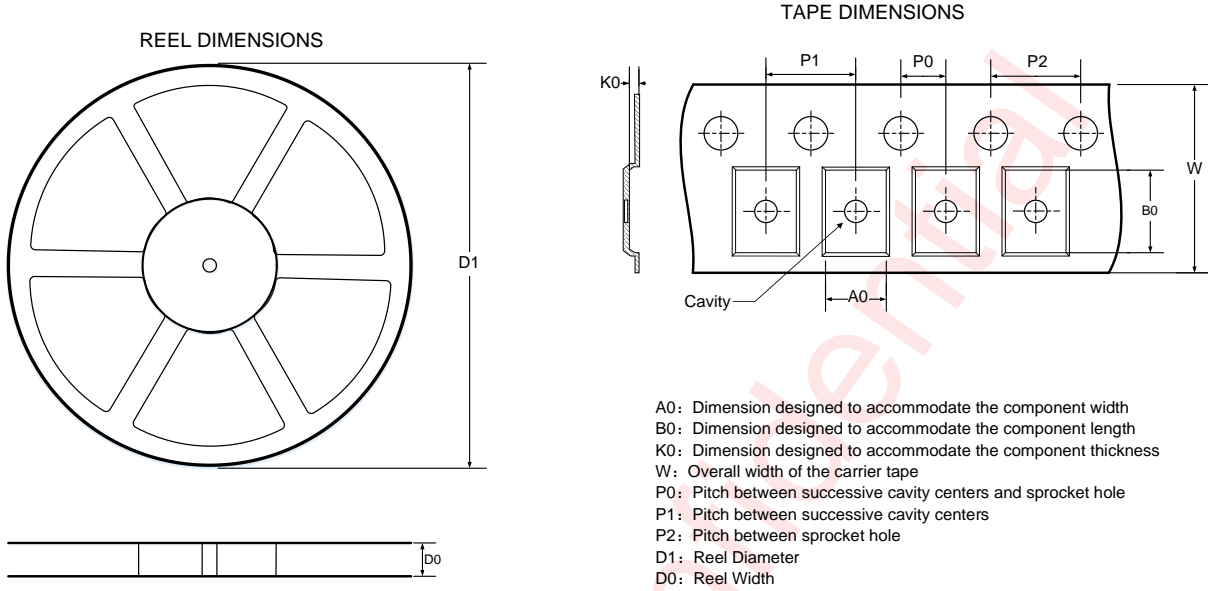

Figure 40 Inverting Gain Application Schematic and Layout Example

## Tape And Reel Information

SOT23 - 5L



Note: The above picture is for reference only. Please refer to the value in the table below for the actual size

DIMENSIONS AND PIN1 ORIENTATION

D1 (mm)	D0 (mm)	A0 (mm)	B0 (mm)	K0 (mm)	P0 (mm)	P1 (mm)	P2 (mm)	W (mm)	Pin1 Quadrant
178	8.4	3.3	3.2	1.4	2	4	4	8	Q3

All dimensions are nominal

MSOP - 8L

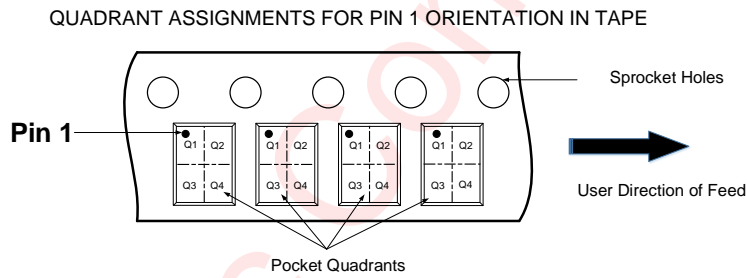
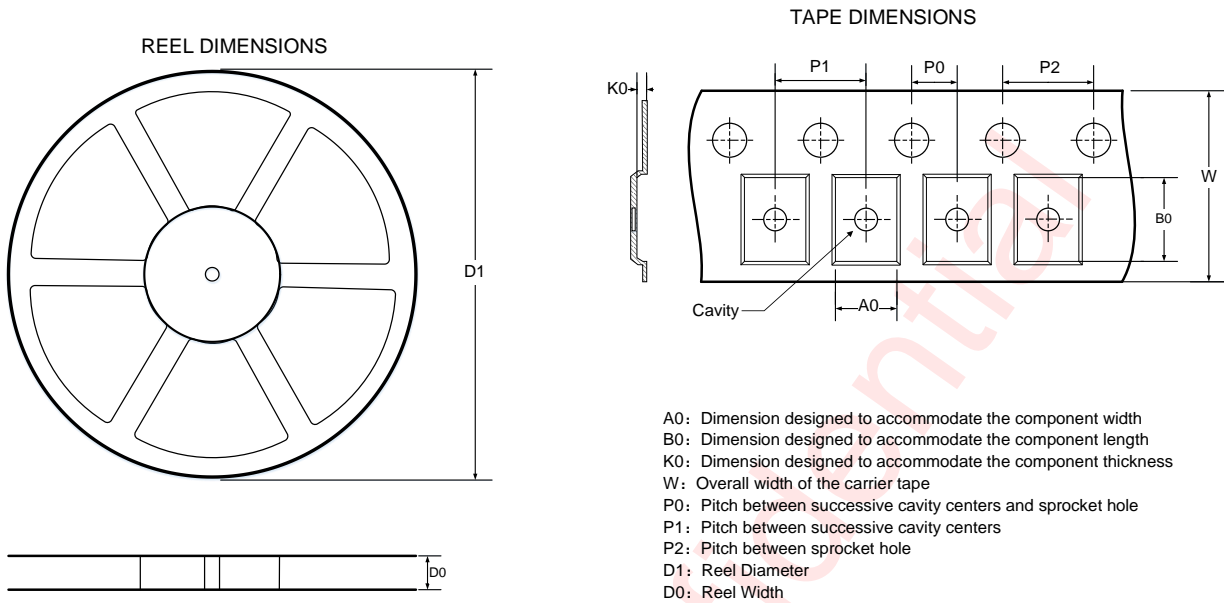

Note: The above picture is for reference only. Please refer to the value in the table below for the actual size

DIMENSIONS AND PIN1 ORIENTATION

D1 (mm)	D0 (mm)	A0 (mm)	B0 (mm)	K0 (mm)	P0 (mm)	P1 (mm)	P2 (mm)	W (mm)	Pin1 Quadrant
330	12.4	5.25	3.35	1.25	2	8	4	12	Q1

All dimensions are nominal

SOP - 8L

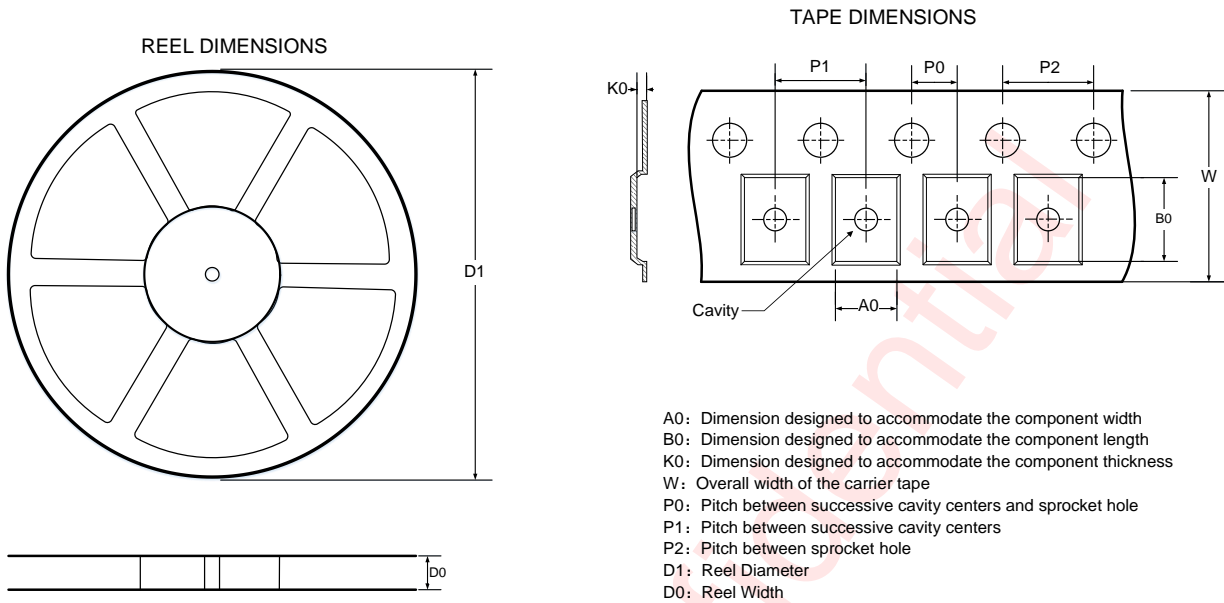

QUADRANT ASSIGNMENTS FOR PIN 1 ORIENTATION IN TAPE

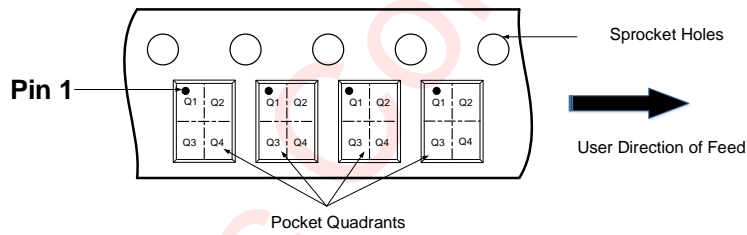

Note: The above picture is for reference only. Please refer to the value in the table below for the actual size

DIMENSIONS AND PIN1 ORIENTATION

D1 (mm)	D0 (mm)	A0 (mm)	B0 (mm)	K0 (mm)	P0 (mm)	P1 (mm)	P2 (mm)	W (mm)	Pin1 Quadrant
330	12.4	6.6	5.3	1.9	2	8	4	12	Q1

All dimensions are nominal

SOP - 14L

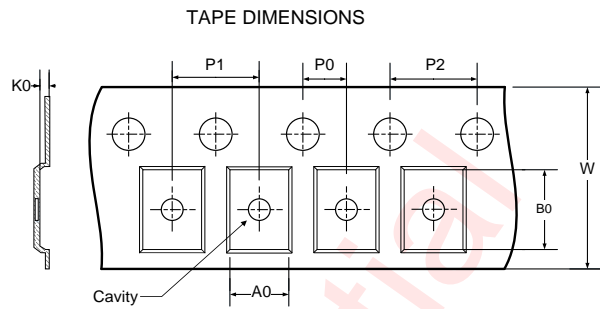
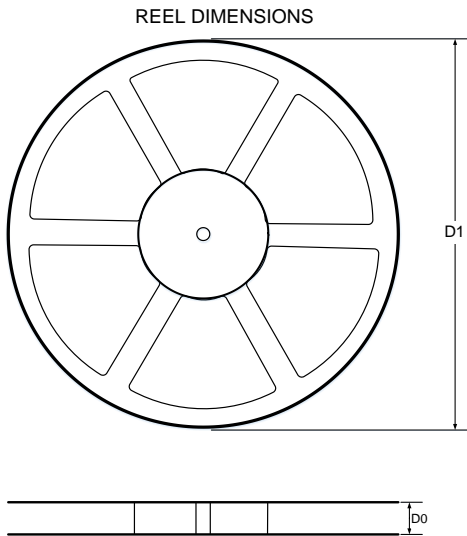

A0: Dimension designed to accommodate the component width  
 B0: Dimension designed to accommodate the component length  
 K0: Dimension designed to accommodate the component thickness  
 W: Overall width of the carrier tape  
 P0: Pitch between successive cavity centers and sprocket hole  
 P1: Pitch between successive cavity centers  
 P2: Pitch between sprocket hole  
 D1: Reel Diameter  
 D0: Reel Width

QUADRANT ASSIGNMENTS FOR PIN 1 ORIENTATION IN TAPE

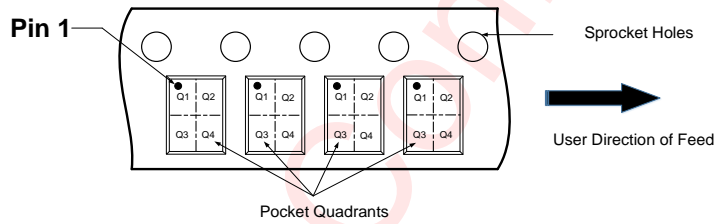

Note: The above picture is for reference only. Please refer to the value in the table below for the actual size

DIMENSIONS AND PIN1 ORIENTATION

D1 (mm)	D0 (mm)	A0 (mm)	B0 (mm)	K0 (mm)	P0 (mm)	P1 (mm)	P2 (mm)	W (mm)	Pin1 Quadrant
330	16.4	6.5	9.3	2	2	8	4	16	Q1

All dimensions are nominal

TSSOP - 14L

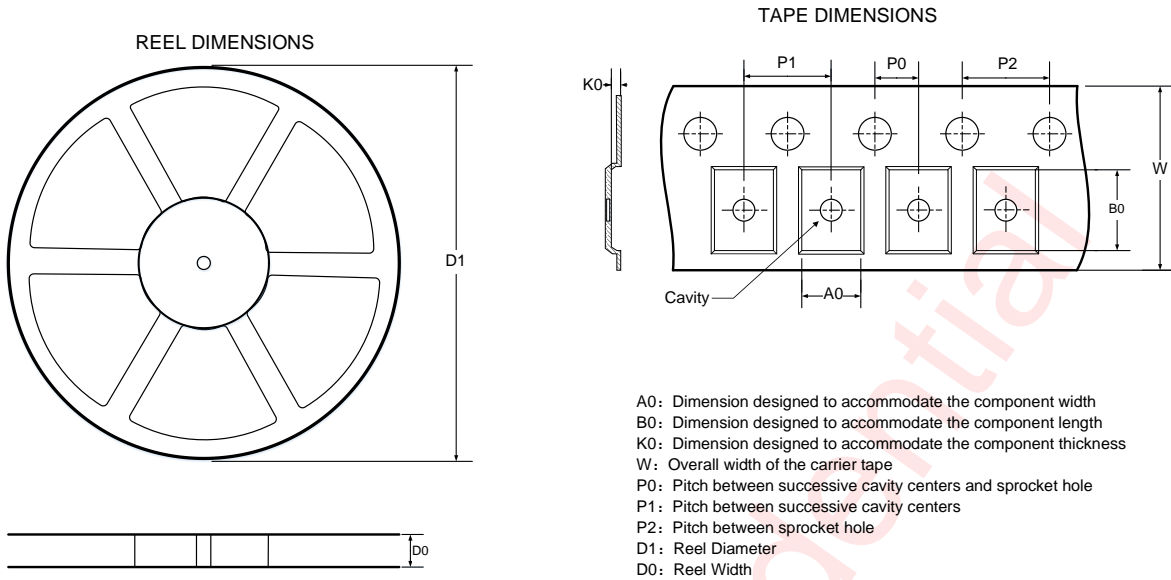

QUADRANT ASSIGNMENTS FOR PIN 1 ORIENTATION IN TAPE

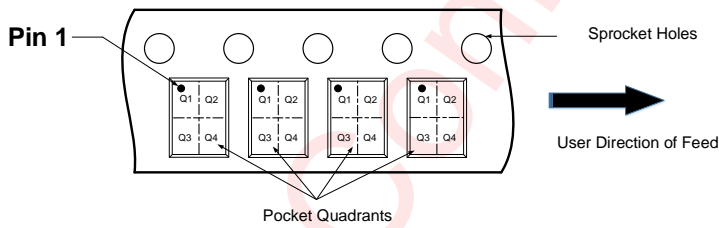

Note: The above picture is for reference only. Please refer to the value in the table below for the actual size

DIMENSIONS AND PIN1 ORIENTATION

D1 (mm)	D0 (mm)	A0 (mm)	B0 (mm)	K0 (mm)	P0 (mm)	P1 (mm)	P2 (mm)	W (mm)	Pin1 Quadrant
330	12.40	6.85	5.45	1.60	2	8	4	12	Q1

All dimensions are nominal

## Package Description

SOT23 - 5L

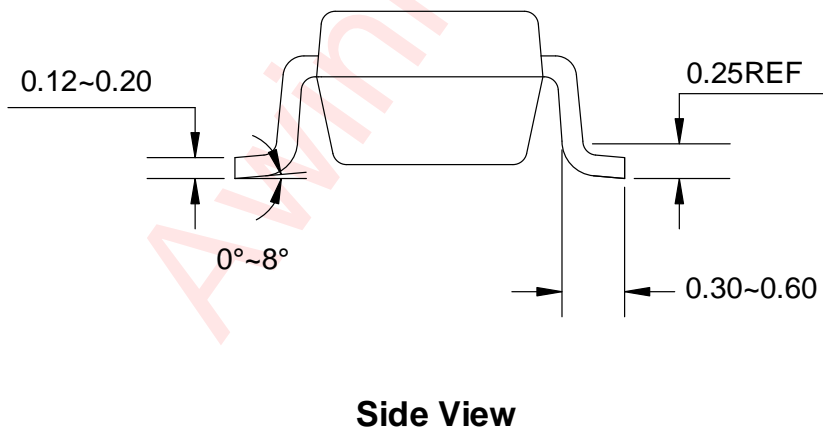
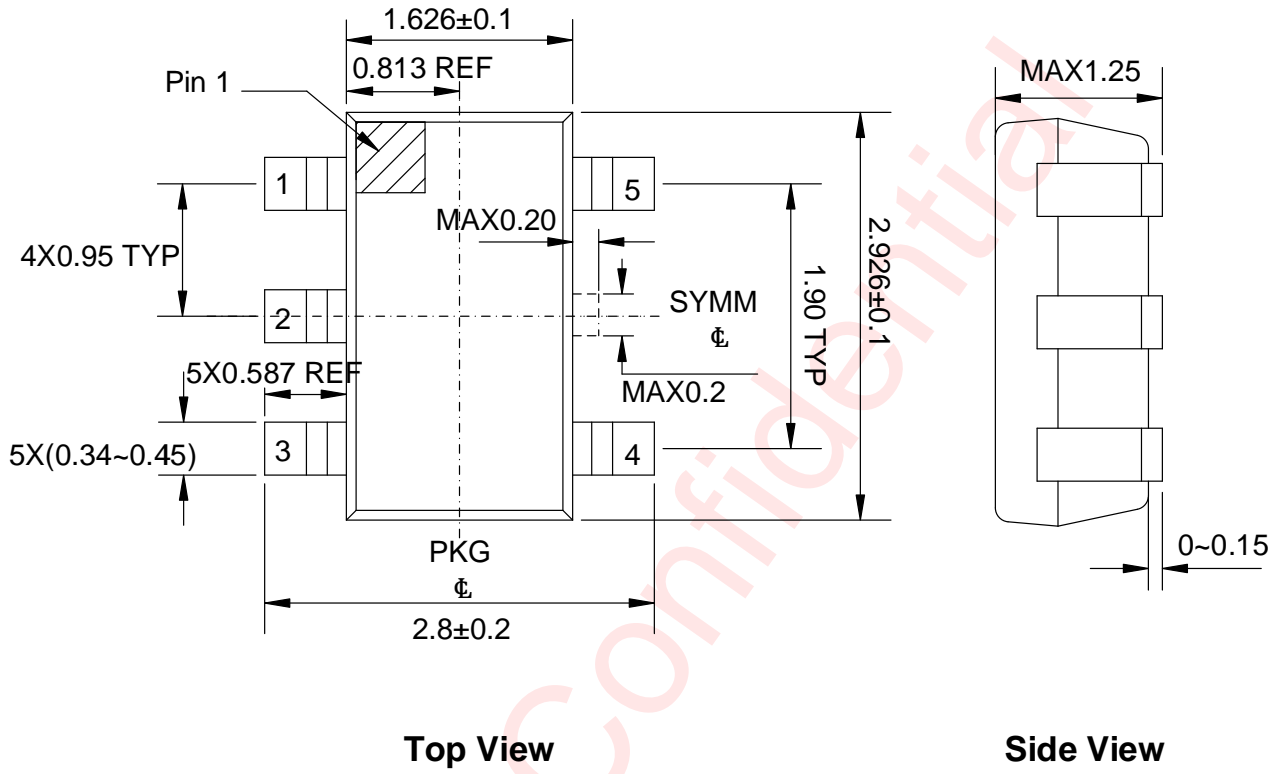

Unit: mm

MSOP - 8L

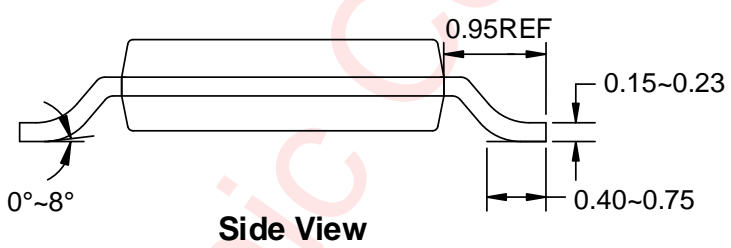
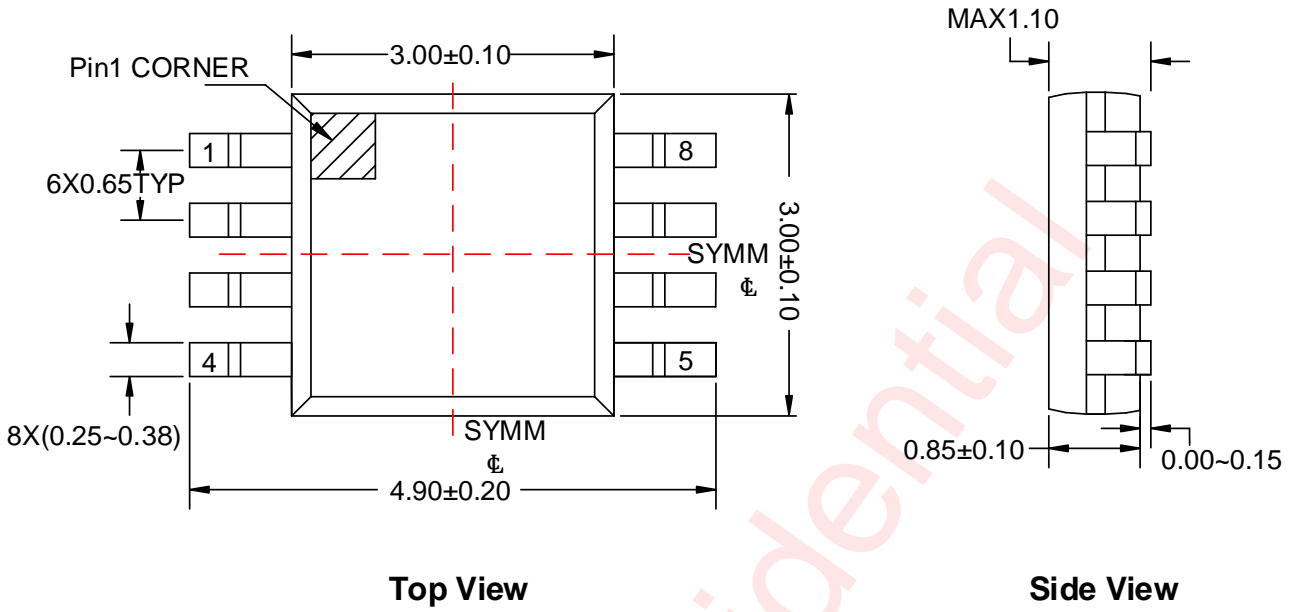

Unit: mm

SOP - 8L

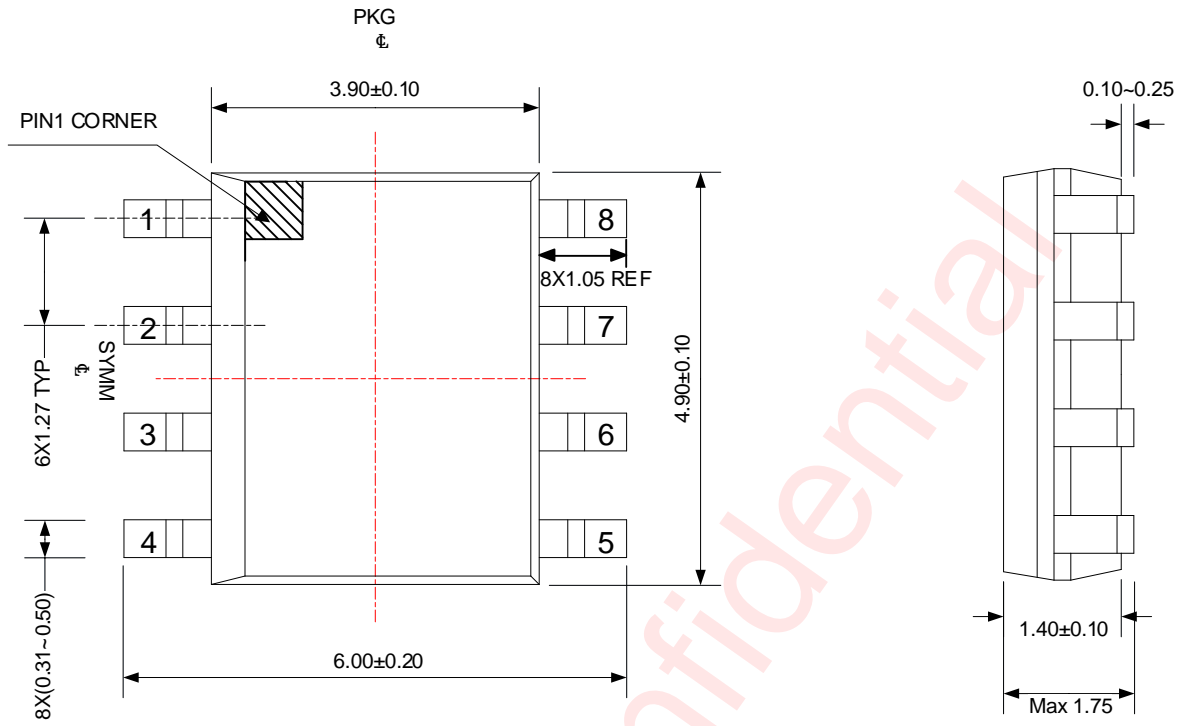

Top View

Side View



Side View

Unit: mm

SOP - 14L

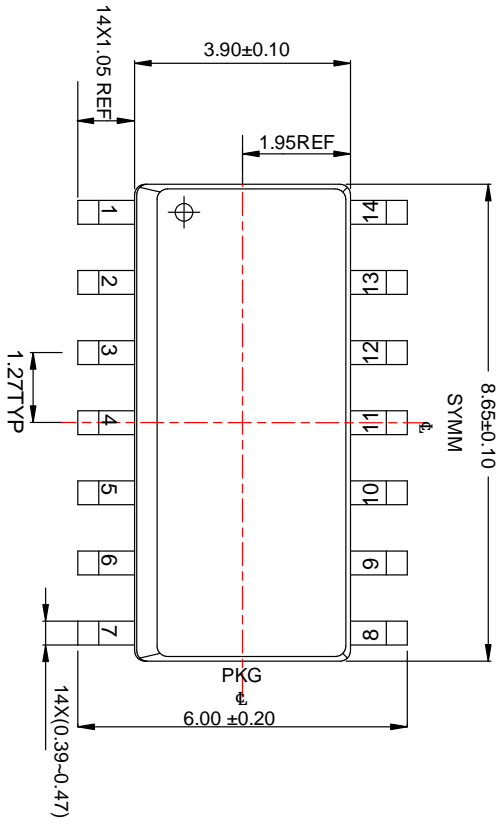

TOP VIEW

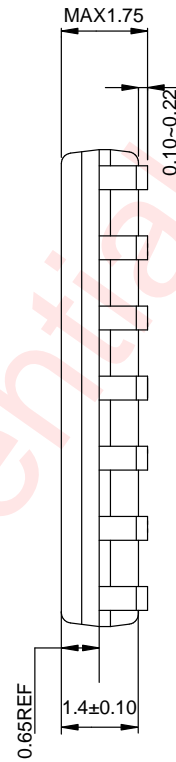

SIDE VIEW

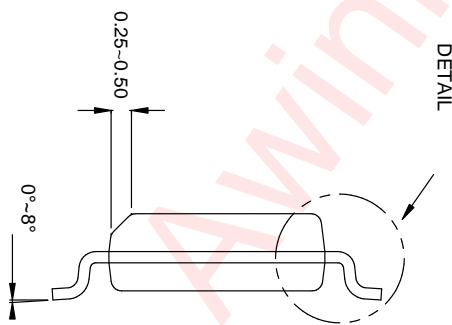

SIDE VIEW

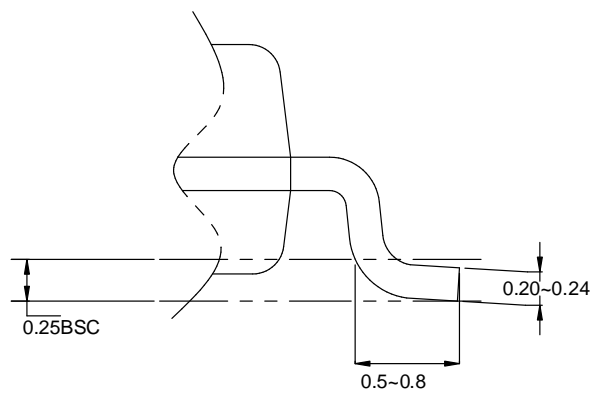

DETAIL

UNIT:mm

TSSOP - 14L

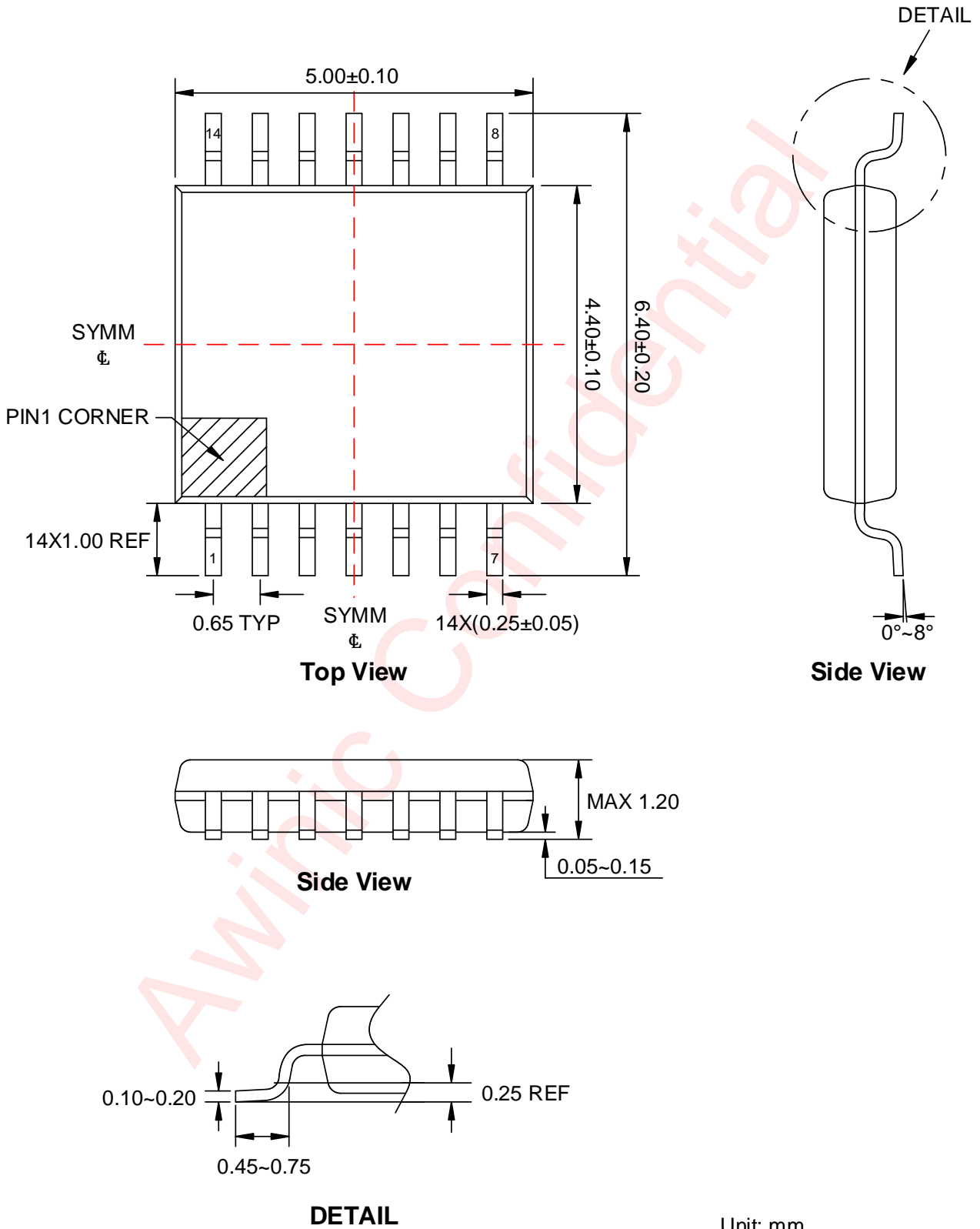

Unit: mm

## Land Pattern Data

SOT23 - 5L

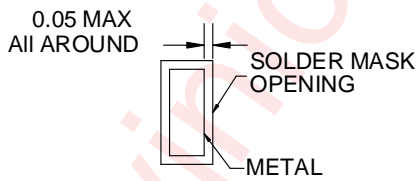
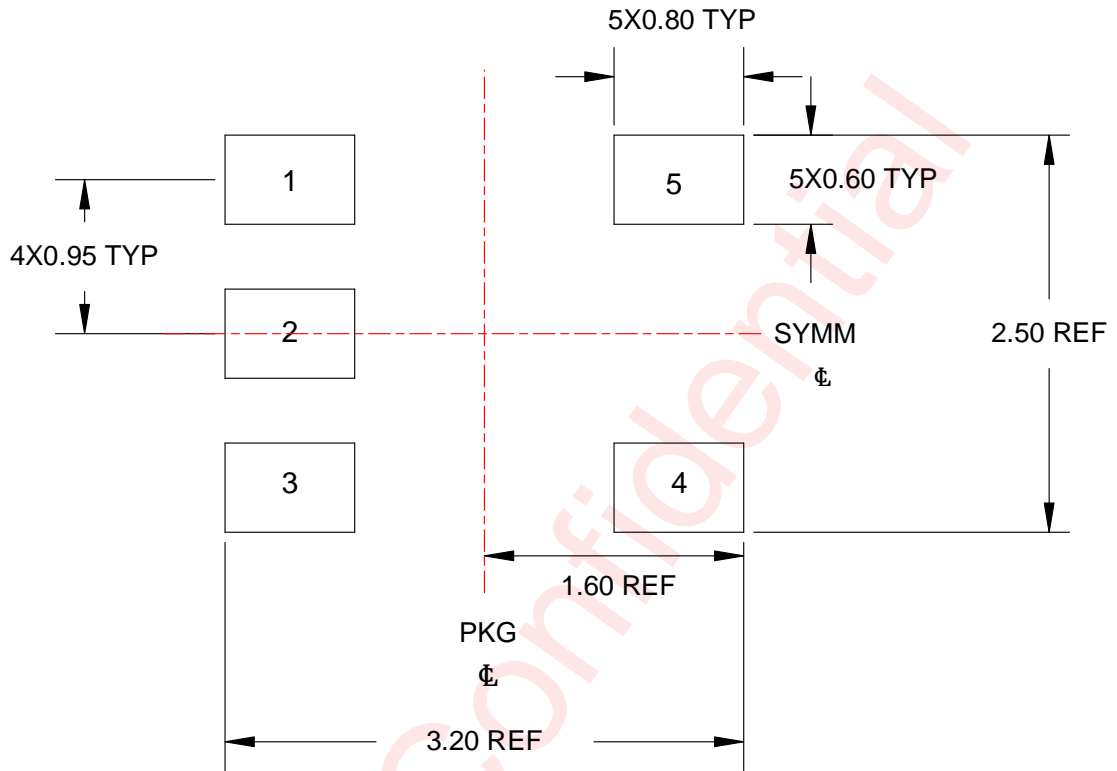

NON SOLDER MASK DEFINED

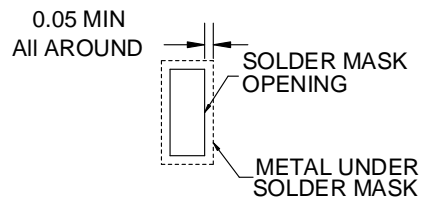

SOLDER MASK DEFINED

Unit: mm

MSOP - 8L

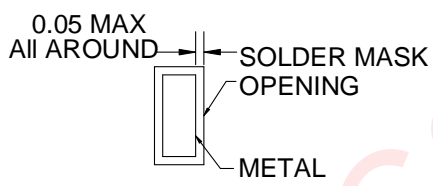
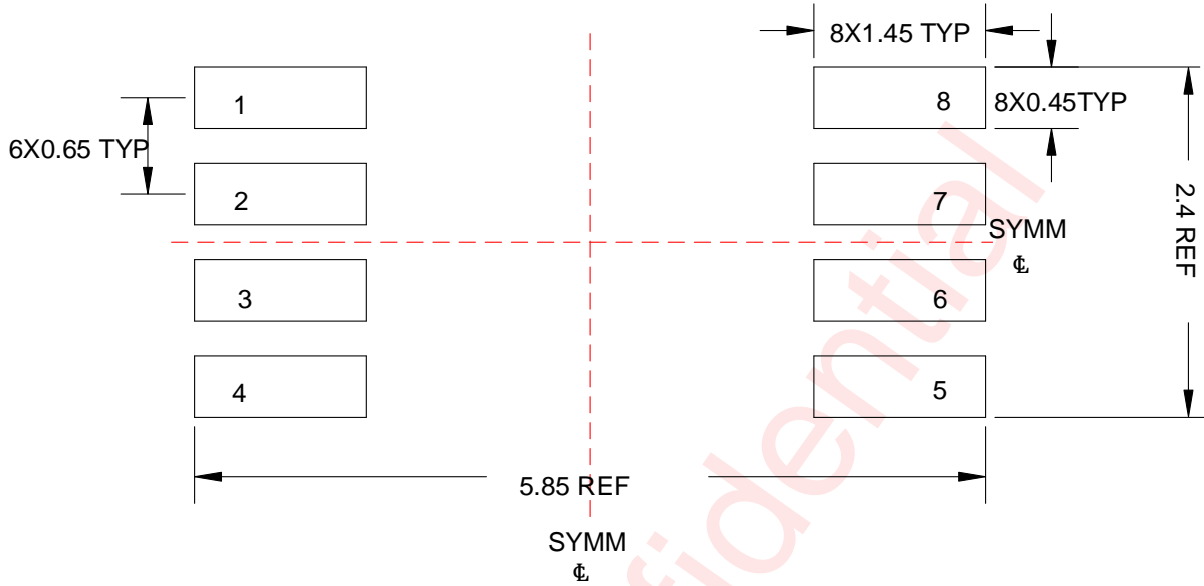

NON SOLDER MASK DEFINED

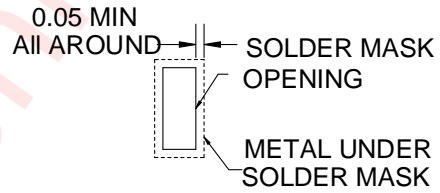

SOLDER MASK DEFINED

Unit: mm

SOP - 8L

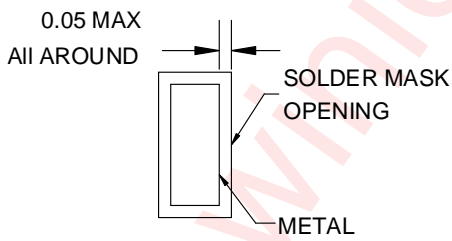
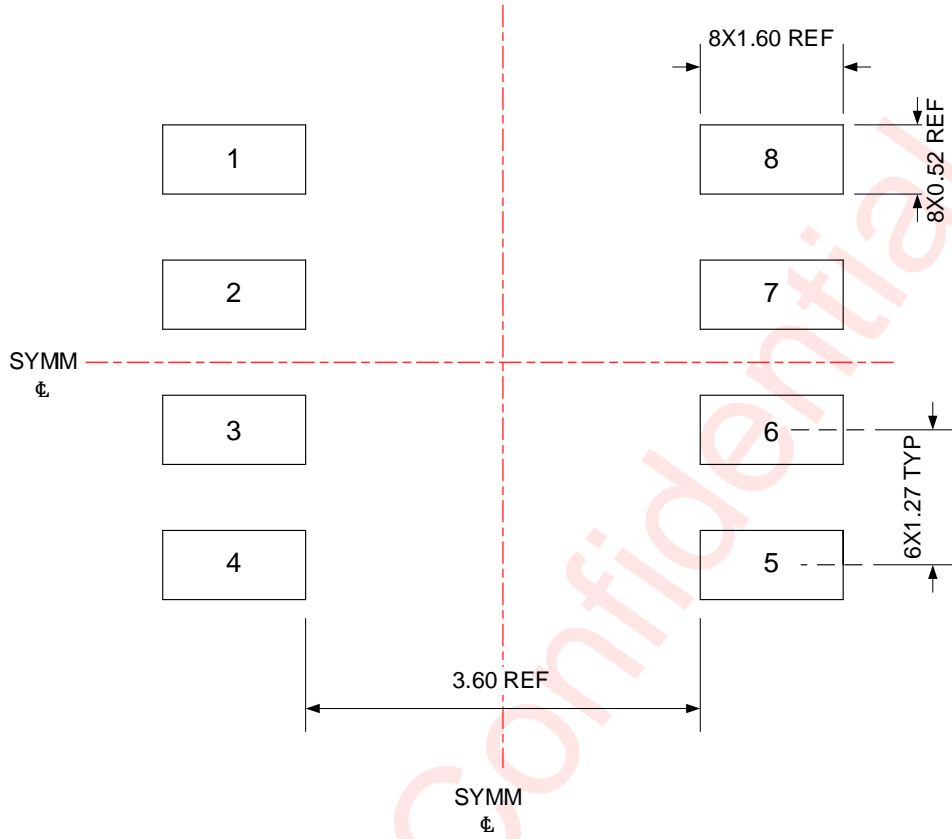

NON SOLDER MASK DEFINED

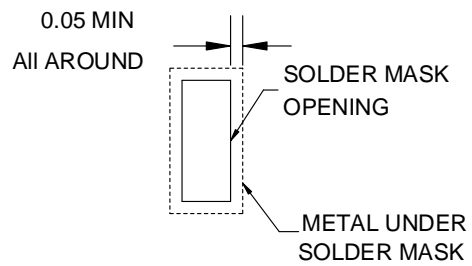

SOLDER MASK DEFINED

Unit: mm

SOP - 14L

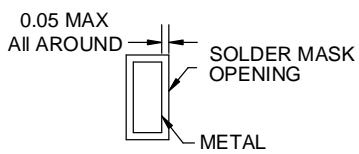
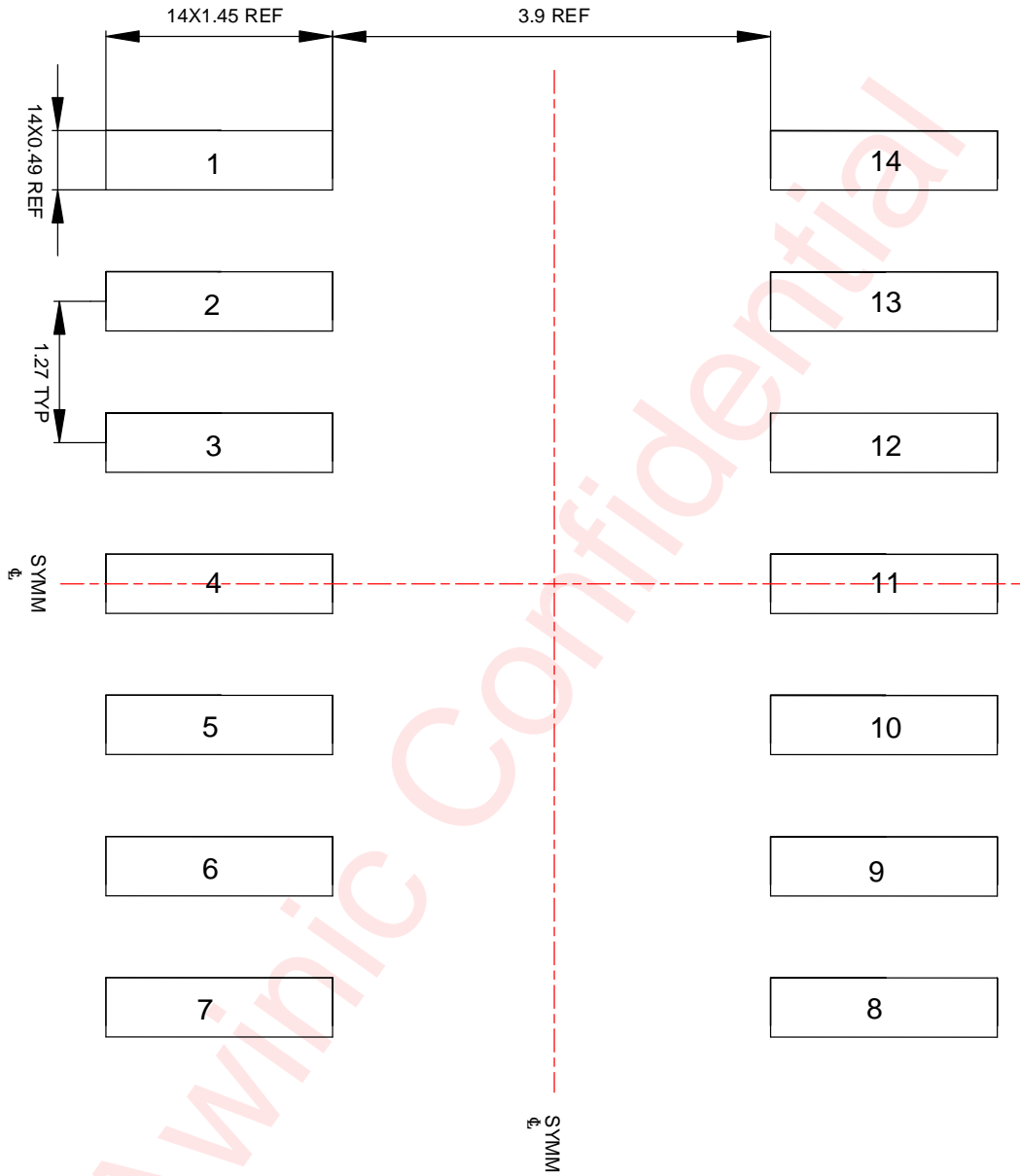

NON-SOLDER MASK DEFINED

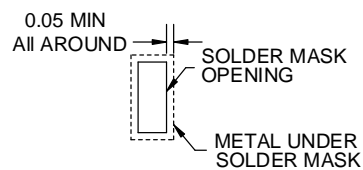

SOLDER MASK DEFINED

Unit: mm

TSSOP - 14L

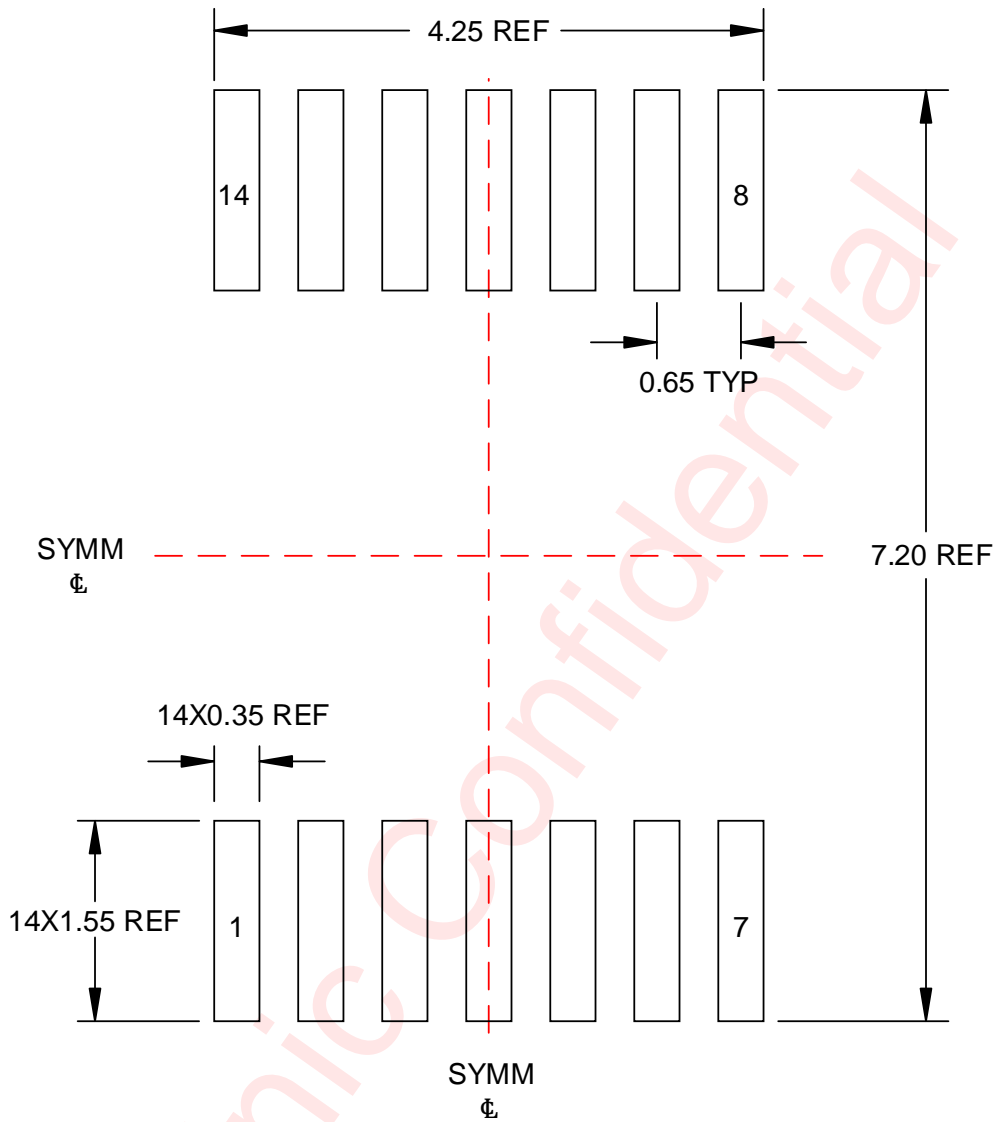

0.05 MAX  
All AROUND

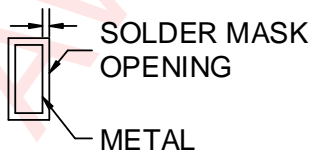

NON-SOLDER MASK DEFINED

0.05 MIN  
All AROUND

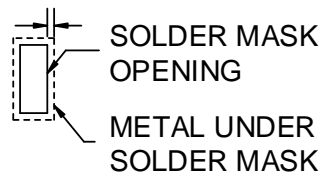

SOLDER MASK DEFINED

Unit: mm

## Revision History

Version	Date	Change Record
V1.0	Sep. 2023	Official released
V1.1	Nov. 2023	<ol style="list-style-type: none"> <li>Added SOP – 8L information. (P1)</li> <li>Added SOP - 8L pin configuration to <i>Pin Configuration And Top Mark</i>. (P2)</li> <li>Added SOP - 8L information table to <i>Ordering Information</i>. (P5)</li> <li>Added SOP - 8L thermal metrics to <i>Thermal Information</i>. (P7)</li> <li>Added SOP - 8L information to <i>Tape And Reel Information</i>. (P22)</li> <li>Added SOP - 8L information to <i>Package Description</i>. (P24)</li> <li>Added SOP - 8L information to <i>Land Pattern Data</i>. (P26)</li> </ol>
V1.2	Nov. 2023	<ol style="list-style-type: none"> <li>Added SOP – 8L <i>thermal information</i>. (P7)</li> </ol>
V1.3	Dec. 2023	<ol style="list-style-type: none"> <li>Update <i>ESD Rating and Latch Up</i>. (P6)</li> </ol>
V1.4	May.2024	<ol style="list-style-type: none"> <li>Update typical value of PSRR and CMRR in <i>Electrical Characteristics</i>. (P8)</li> </ol>
V1.5	Jun.2024	<ol style="list-style-type: none"> <li>Update BODY SIZE(NOM) in <i>Device Information</i>. (P1)</li> </ol>
V1.6	Oct.2024	<ol style="list-style-type: none"> <li>Added SOT23 - 5L and Sop – 14L information. (P1)</li> <li>Added SOT23 - 5L and Sop – 14L Pin configuration to <i>Pin Configuration And Top Mark</i>. (P2)</li> <li>Added SOT23 - 5L and Sop – 14L Pin Definition. (P4)</li> <li>Added SOT23 - 5L and Sop – 14L information table to <i>Ordering Information</i>. (P7)</li> <li>Added SOT23 - 5L and Sop – 14L <i>Layout Example</i>. (P21)</li> <li>Added SOT23 - 5L and Sop – 14L information to <i>Tape And Reel Information</i>. (P24)</li> <li>Added SOT23 - 5L and Sop – 14L information to <i>Package Description</i>. (P28)</li> <li>Added SOT23 - 5L and Sop – 14L information to <i>Land Pattern Data</i>. (P32)</li> </ol>
V1.7	Apr.2025	<ol style="list-style-type: none"> <li>Update PSRR in <i>Electrical Characteristics</i>. (P10)</li> <li>Update MSOP - 8L information in <i>Package Description</i>. (P29)</li> <li>Update SOP - 8L information in <i>Package Description</i>. (P30)</li> </ol>
V1.8	Dec.2025	<ol style="list-style-type: none"> <li>Added TSSOP – 14L information to <i>Device Information</i>. (P1)</li> <li>Added TSSOP – 14L Pin configuration to <i>Pin Configuration And Top Mark</i>. (P4)</li> <li>Added TSSOP – 14L Pin Definition. (P5、 P6)</li> <li>Added TSSOP – 14L information table to <i>Ordering Information</i>. (P8)</li> <li>Added TSSOP – 14L to <i>Layout Example</i>. (P23)</li> <li>Added TSSOP – 14L information to <i>Tape And Reel Information</i>. (P29)</li> <li>Added TSSOP – 14L information to <i>Package Description</i>. (P34)</li> <li>Added TSSOP – 14L information to <i>Land Pattern Data</i>. (P39)</li> </ol>

## Disclaimer

All trademarks are the property of their respective owners. Information in this document is believed to be accurate and reliable. However, Shanghai AWINIC Technology Co., Ltd (AWINIC Technology) does not give any representations or warranties, expressed or implied, as to the accuracy or completeness of such information and shall have no liability for the consequences of use of such information.

AWINIC Technology reserves the right to make changes to information published in this document, including without limitation specifications and product descriptions, at any time and without notice. Customers shall obtain the latest relevant information before placing orders and shall verify that such information is current and complete. This document supersedes and replaces all information supplied prior to the publication hereof.

AWINIC Technology products are not designed, authorized or warranted to be suitable for use in medical, military, aircraft, space or life support equipment, nor in applications where failure or malfunction of an AWINIC Technology product can reasonably be expected to result in personal injury, death or severe property or environmental damage. AWINIC Technology accepts no liability for inclusion and/or use of AWINIC Technology products in such equipment or applications and therefore such inclusion and/or use is at the customer's own risk.

Applications that are described herein for any of these products are for illustrative purposes only. AWINIC Technology makes no representation or warranty that such applications will be suitable for the specified use without further testing or modification.

All products are sold subject to the general terms and conditions of commercial sale supplied at the time of order acknowledgement.

Nothing in this document may be interpreted or construed as an offer to sell products that is open for acceptance or the grant, conveyance or implication of any license under any copyrights, patents or other industrial or intellectual property rights.

Reproduction of AWINIC information in AWINIC data books or data sheets is permissible only if reproduction is without alteration and is accompanied by all associated warranties, conditions, limitations, and notices. AWINIC is not responsible or liable for such altered documentation. Information of third parties may be subject to additional restrictions.

Resale of AWINIC components or services with statements different from or beyond the parameters stated by AWINIC for that component or service voids all express and any implied warranties for the associated AWINIC component or service and is an unfair and deceptive business practice. AWINIC is not responsible or liable for any such statements.