

NX-□

# NX series I/O

## Speed and accuracy for machine performance

NX series I/O covers a full range of units, including standard and high-speed digital I/O's, analog I/O's, encoder inputs, pulse outputs and safety control.

- Standard, high-speed and Time Stamp I/O units
- Safety controller and safety I/O units can be integrated
- IO-Link master unit for sensors reducing machine downtime
- EtherCAT and EtherNet/IP communication options
- Detachable front connector with screwless push-in terminals for direct field wiring
- Digital I/O models with 20/40 pin "flatcable" connectors for fast connection to custom wiring looms
- High signal density: Up to 16 digital or 8 analog signals in 12 mm width



## System configuration

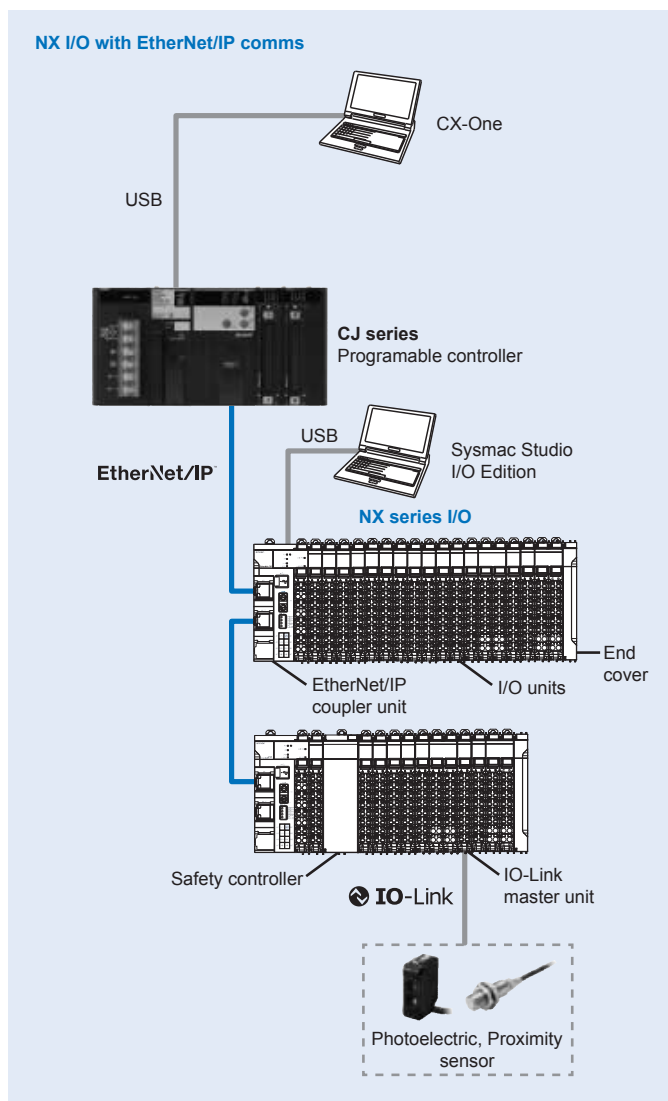
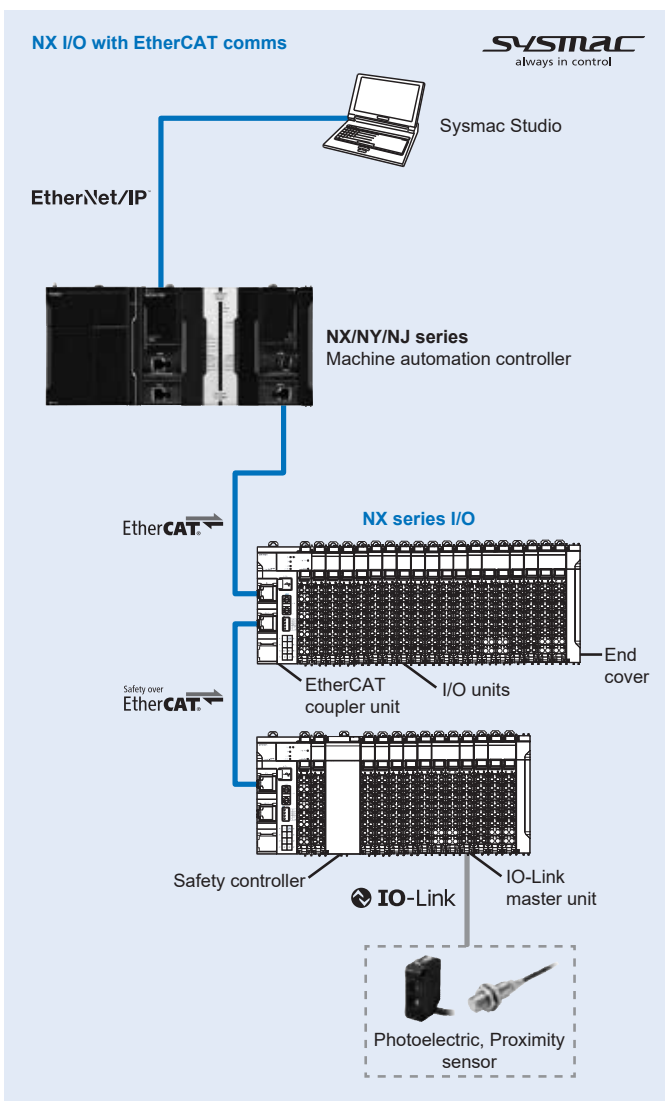

Specifications

General specifications

Item	Specifications	
Enclosure	Mounted in a panel	
Operating environment	Ambient operating temperature	0 to 55°C
	Ambient operating humidity	10% to 95% (with no condensation or icing)
	Atmosphere	Must be free from corrosive gases
	Ambient storage temperature	-25 to 70°C (with no condensation or icing)
	Altitude	2,000 m max.
	Pollution degree	2 or less: conforms to JIS B3502 and IEC 61131-2
	Noise immunity	2 kV on power supply line: conforms to IEC 61000-4-4.
	Overvoltage category	Category II: Conforms to JIS B3502 and IEC 61131-2
	EMC immunity level	Zone B
	Vibration resistance	Conforms to IEC 60068-2-6. 5 to 8.4 Hz with 3.5-mm amplitude, 8.4 to 150 Hz, acceleration of 9.8 m/s <sup>2</sup> , 100 min each in X, Y and Z directions (10 sweeps of 10 min each = 100 min total)
Shock resistance	Conforms to IEC 60068-2-27. 147 m/s <sup>2</sup> , 3 times each in X, Y and Z directions	
Applicable standards	cULus: Listed UL508 and ANSI/ISA 12.12.01 EC: EN 61131-2 and C-Tick, KC registration, NK, LR	

EtherCAT / EtherNet/IP communication specifications

Item	EtherCAT	EtherNet/IP
Physical layer	100BASE-TX (IEEE 802.3)	
Modulation	Baseband	
Link speed	100 Mbps	
Topology	Depends on the specifications of the EtherCAT master	Line, Tree, Star
Transmission media	Category 5 or higher twisted-pair cable (recommended cable: double-shielded cable with foil and braiding, SF/UTP or S/FTP)	
Transmission distance	Distance between nodes: 100 m or less	

Nomenclature

Communication coupler unit (EtherCAT and EtherNet/IP)

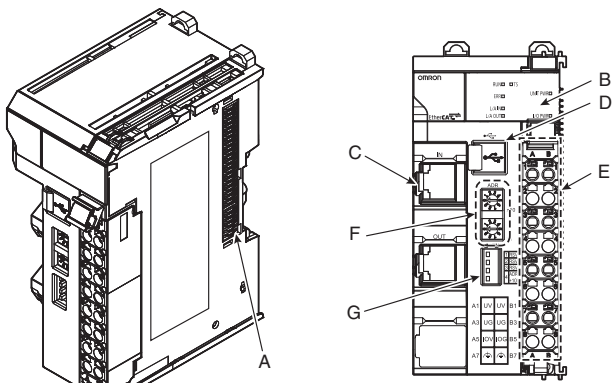

Symbol	Name	Function
A	NX bus connector	This connector is used to connect each unit.
B	Indicators	The indicators show the current operating status of the unit.
C	Communication ports	These ports are connected to the communication cables of the network. There are two connectors, allowing daisy-chaining of communication units.
D	Peripheral USB port	This port is used to connect to the Sysmac Studio software.
E	Terminal block	The terminal block is used to connect external devices. The number of terminals depends on the type of unit.
F	Rotary switches	These rotary switches are used to set the node address. The address is set in decimal for EtherCAT and in hexadecimal for EtherNet/IP.
G	DIP switch	The DIP switch is used to set the 100s digit of the node address of the coupler unit.

Terminal block types

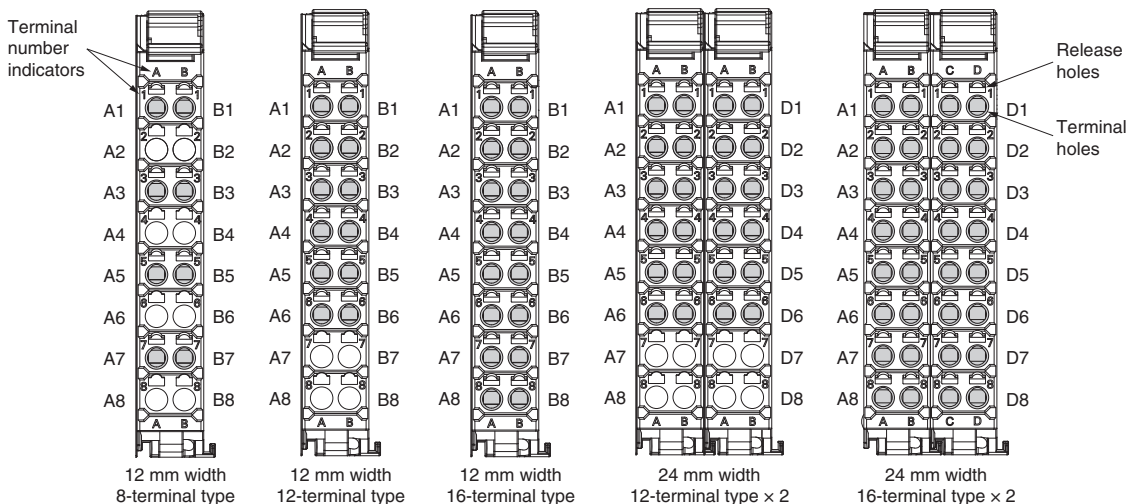

Communication coupler unit

EtherCAT communication coupler unit

Item	Specifications	
Model	NX-ECC203	
Number of connectable NX units	63 units max. <sup>*1</sup>	
Communications protocol	EtherCAT protocol	
Send/receive PDO data sizes	Input: 1024 bytes max. (including input data, status and unused areas) Output: 1024 bytes max. (including output data and unused areas)	
Mailbox data size	Input: 256 bytes / Output: 256 bytes	
Mailbox	Emergency messages and SDO requests	
Refreshing methods <sup>*2</sup>	Free-run refreshing Synchronous I/O refreshing Time Stamp refreshing Task period prioritized refreshing	
Node address setting range	When the settable node address range for the built-in EtherCAT port is 1 to 512 <sup>*3</sup> : Set on switches: 1 to 199 Set with Sysmac Studio: 1 to 512 When the settable node address range for the built-in EtherCAT port is 1 to 192 <sup>*3</sup> : Set on switches: 1 to 192 Set with Sysmac Studio: 1 to 192	
I/O jitter performance	Inputs: 1 μs max. / Outputs: 1 μs max.	
Communications cycle in DC mode	125 to 10,000 μs <sup>*4 *5 *6</sup>	
Unit power supply	Voltage	24 VDC (20.4 to 28.8 VDC)
	Capacity	10 W max.
	Efficiency	70%
	Isolation method	No isolation between NX unit power supply and unit power supply terminals
	Unwired terminal current capacity	4 A max.
I/O power supply	Voltage	5 to 24 VDC (4.5 to 28.8 VDC) <sup>*7</sup>
	Maximum I/O current	10 A
	Terminal current capacity	10 A max.
Unit power consumption	1.25 W max.	
Current consumption from I/O power supply	10 mA max. (for 24 VDC)	
Dielectric strength	510 VAC for 1 min, leakage current: 5 mA max. (between isolated circuits)	
Insulation resistance	100 VDC, 20 MΩ min. (between isolated circuits)	
External connection terminals	Connector for EtherCAT communications: RJ45 × 2 (shielded) IN/OUT: EtherCAT input/output data Screwless push-in terminal (8 terminals) For power supply unit, I/O power supply and grounding. Removable. Peripheral USB port for Sysmac Studio connection: Physical layer: USB 2.0-compliant, B-type connector Transmission distance: 5 m max.	
Terminal block type	Screwless push-in terminal 8 terminals (A + B with FG)	
Dimensions (W x H x D)	46 x 100 x 71 mm	
Weight	170 g max.	

- \*1. Refer to the NX-safety control units user's manual (Cat.No. Z930) for the number of safety control units that can be connected.
- \*2. This function was added or improved for a version upgrade. Refer to the NX-series EtherCAT coupler unit user's manual (Cat.No. W519) for information on version upgrades.
- \*3. The range of node addresses that can be set depends on the model of the built-in EtherCAT port. For the node address ranges that can be set for a built-in EtherCAT port, refer to the user's manual for the built-in EtherCAT port on the connected CPU unit or Industrial PC.
- \*4. This depends on the specifications of the EtherCAT master. For example, the values are as follows when you are connected to the built-in EtherCAT port on an NJ5-series CPU unit: 500 μs, 1,000 μs, 2,000 μs and 4,000 μs. For the specifications of the built-in EtherCAT port, refer to the user's manual for the built-in EtherCAT port on the connected CPU unit or the Industrial PC.
- \*5. This depends on the unit configuration.
- \*6. There are restrictions in the communications cycles that you can set for some of the NX Units. If you use any of those NX units, set a communications cycle that will satisfy the specifications for the refresh cycles that can be executed by the NX unit. Refer to the appendix of the NX-series data reference manual (Cat. No. W525-E1-07 or later) to see if there are restrictions on any specific NX units. For information on the communications cycles that you can set, refer to the user's manuals for the NX units.
- \*7. Use an output voltage that is appropriate for the I/O circuits of the NX units and the connected external devices.

Circuit layout

NX-ECC203

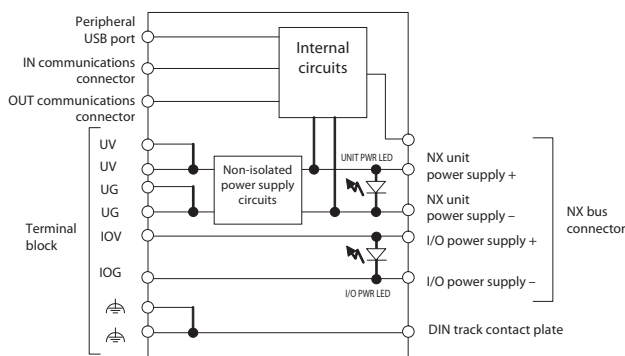

Terminal wiring

NX-ECC203

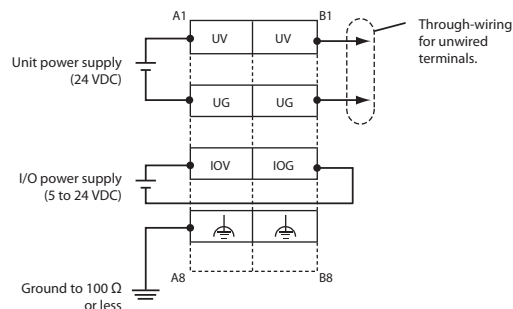

## EtherNet/IP communication coupler unit

Item	Specifications	
Model	<b>NX-EIC202</b>	
Number of connectable NX units	63 units max. <sup>*1</sup>	
Communication protocols	EtherNet/IP protocol UDP/IP and TCP/IP (Message Services) No. of buffers (sockets): 8 message buffers for servers. No message buffer for client. Shared buffers for UDP/IP and TCP/IP messages. Max. message size: Request 492 bytes / Response 496 bytes Max. NX output data size: 490 bytes Max. NX input data size: 496 bytes	
Number of connections	8	
Received packet interval (RPI, refresh cycle)	4 to 1,000 ms	
Allowed communications bandwidth per unit	1,000 pps	
NX bus I/O data size	Input: 512 bytes max. (including input data, status and unused areas) Output: 512 bytes max. (including output data and unused areas)	
EtherNet/IP I/O connection size	Input: 504 bytes max. (including input data, status and unused areas) Output: 504 bytes max. (including output data and unused areas)	
Refreshing methods	Free-run refreshing	
Unit power supply	<b>Voltage</b>	24 VDC (20.4 to 28.8 VDC)
	<b>Capacity</b>	10 W max.
	<b>Efficiency</b>	70%
	<b>Isolation method</b>	No isolation between NX unit power supply and unit power supply terminals
	<b>Unwired terminal current capacity</b>	4 A max.
I/O power supply	<b>Voltage</b>	5 to 24 VDC (4.5 to 28.8 VDC) <sup>*2</sup>
	<b>Maximum I/O current</b>	10 A
	<b>Terminal current capacity</b>	10 A max.
Unit power consumption	1.60 W max.	
Current consumption from I/O power supply	10 mA max. (for 24 VDC)	
Dielectric strength	510 VAC for 1 min, leakage current: 5 mA max. (between isolated circuits)	
Insulation resistance	100 VDC, 20 MΩ min. (between isolated circuits)	
External connection terminals	Connector for EtherNet/IP communications: RJ45 × 2 (shielded) Screwless push-in terminal (8 terminals) For power supply unit, I/O power supply and grounding. Removable. Peripheral USB port for Sysmac Studio connection: Physical layer: USB 2.0-compliant, B-type connector Transmission distance: 5 m max.	
Terminal block type	Screwless push-in terminal 8 terminals (A + B with FG)	
Dimensions (W x H x D)	46 × 100 × 71 mm	
Weight	150 g max.	

\*1. Refer to the NX-safety control units user's manual (Cat.No. Z930) for the number of safety control units that can be connected.

\*2. Use an output voltage that is appropriate for the I/O circuits of the NX units and the connected external devices.

### Circuit layout

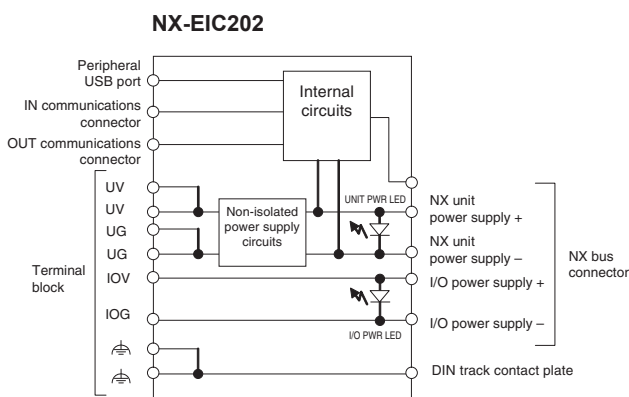

### Terminal wiring

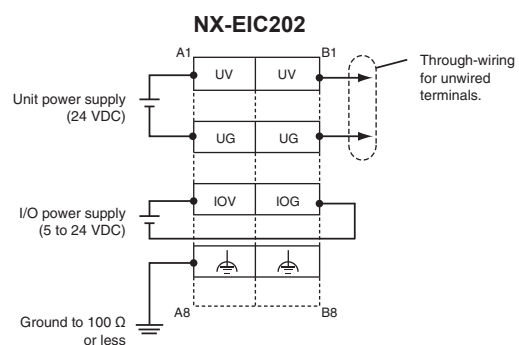

Digital I/O unit

Digital input unit (24 VDC)

Item	Specifications							
Model	NX-ID3317	NX-ID4342	NX-ID5342	NX-ID3343	NX-ID3417	NX-ID4442	NX-ID5442	NX-ID3443
Name	DC input unit							
Internal I/O common	NPN				PNP			
Capacity	4 points	8 points	16 points	4 points	4 points	8 points	16 points	4 points
Rated input voltage	12 to 24 VDC (9 to 28.8 VDC)		24 VDC (15 to 28.8 VDC)		12 to 24 VDC (9 to 28.8 VDC)		24 VDC (15 to 28.8 VDC)	
Input current <sup>1</sup>	6 mA	3.5 mA	2.5 mA	3.5 mA	6 mA	3.5 mA	2.5 mA	3.5 mA
ON voltage	9 VDC min.	15 VDC min.			9 VDC min.	15 VDC min.		
ON current	3 mA min.	3 mA min.	2 mA min.	3 mA min.	3 mA min.	3 mA min.	2 mA min.	3 mA min.
OFF voltage	2 VDC max.		5 VDC max.		2 VDC max.		5 VDC max.	
OFF current	1 mA max.		0.5 mA max.		1 mA max.		0.5 mA max.	
ON/OFF response time	20 μs max./400 μs max.			100 ns max.		20 μs max./400 μs max.		
Input filter time	Default setting: 1 ms <sup>2</sup>			Default setting: 8 μs <sup>3</sup>		Default setting: 1 ms <sup>2</sup>		
Dielectric strength	510 VAC between isolated circuits for 1 minute at a leakage current of 5 mA max.							
Insulation resistance	20 MΩ min. between isolated circuits (at 100 VDC)							
Isolation method	Photocoupler isolation				Digital isolator		Photocoupler isolation	
Unit power consumption	0.50 W max.	0.50 W max.	0.55 W max.	0.55 W max.	0.50 W max.	0.50 W max.	0.55 W max.	0.55 W max.
I/O power supply method	Supply from the NX bus							
I/O current consumption	No consumption			30 mA max.		No consumption		
Current capacity of I/O power supply terminal	0.1 A/terminal max.		Without I/O power supply terminals		0.1 A/terminal max.		Without I/O power supply terminals	
I/O refreshing method	Switching synchronous I/O refreshing and free-run refreshing							
Terminal block type	Screwless push-in terminal 12 terminals (A + B)	Screwless push-in terminal 16 terminals (A + B)	Screwless push-in terminal 16 terminals (A + B)	Screwless push-in terminal 12 terminals (A + B)	Screwless push-in terminal 12 terminals (A + B)	Screwless push-in terminal 16 terminals (A + B)	Screwless push-in terminal 16 terminals (A + B)	Screwless push-in terminal 12 terminals (A + B)
Dimensions (W x H x D)	12 x 100 x 71 mm							
Weight	65 g max.							
Disconnection/short-circuit detection	Not supported							
Protective function	Not supported							

\*1. Typical rated current at 24 VDC.

\*2. Input filter time: No filter, 0.25, 0.5, 1, 2, 4, 8, 16, 32, 64, 128, 256 ms.

\*3. Input filter time: No filter, 1, 2, 4, 8, 16, 32, 64, 128, 256 μs.

Circuit layout

NX-ID3317

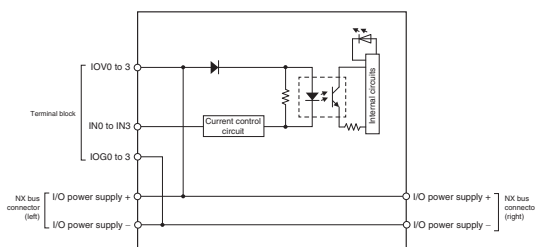

NX-ID3343

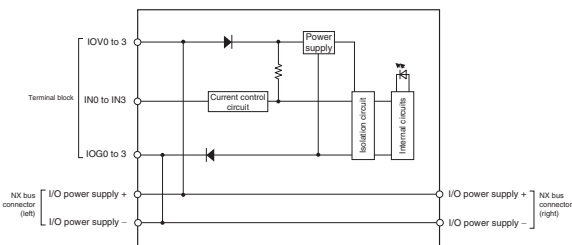

NX-ID4342

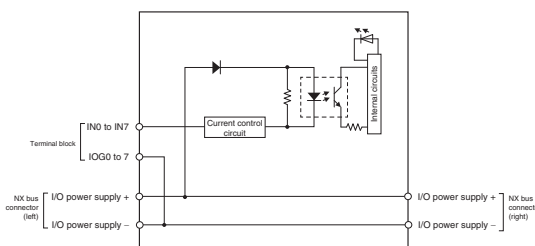

Terminal wiring

NX-ID3317

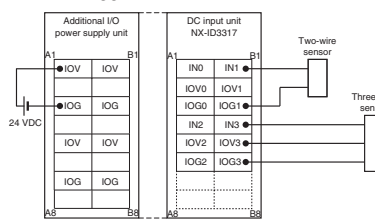

NX-ID3343

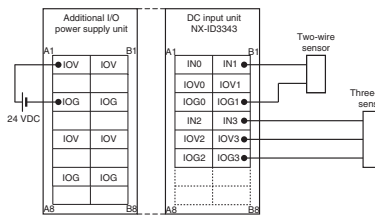

NX-ID4342

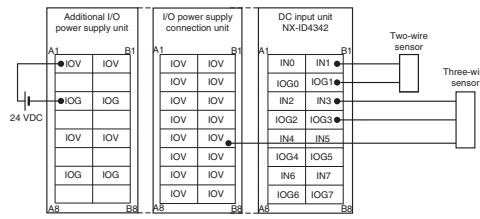

Circuit layout

NX-ID5342

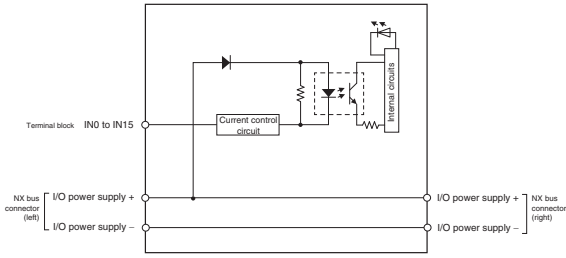

NX-ID3417

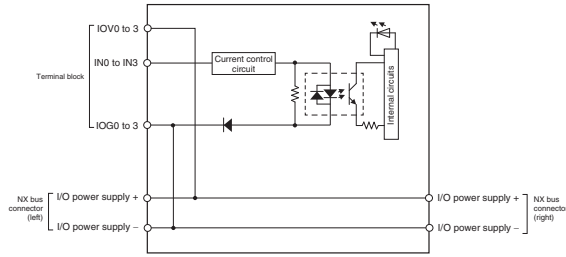

NX-ID3443

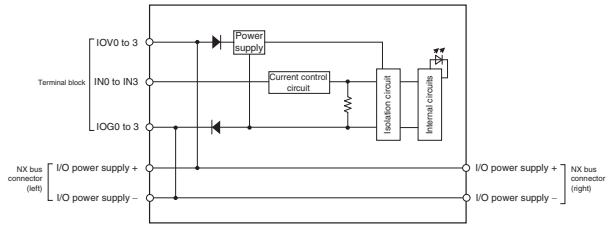

NX-ID4442

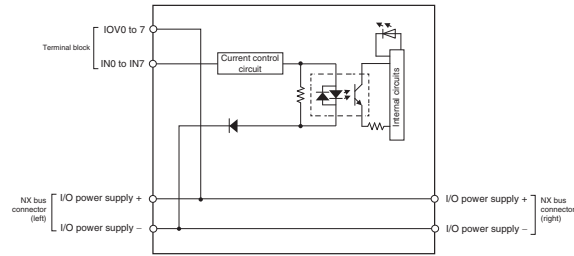

NX-ID5442

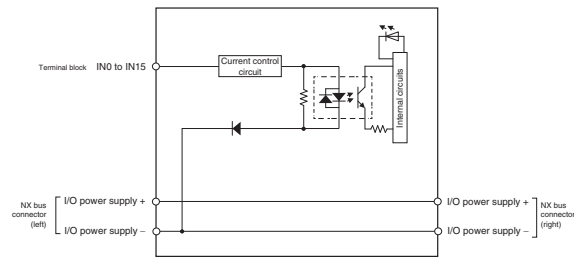

Terminal wiring

NX-ID5342

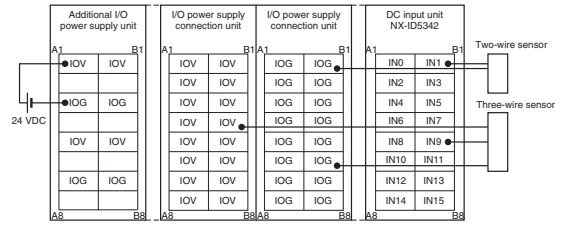

NX-ID3417

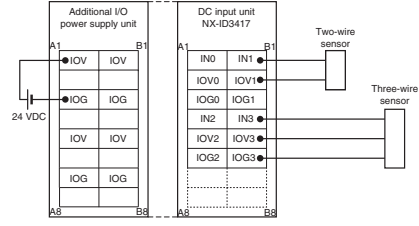

NX-ID3443

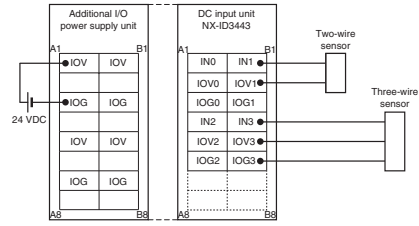

NX-ID4442

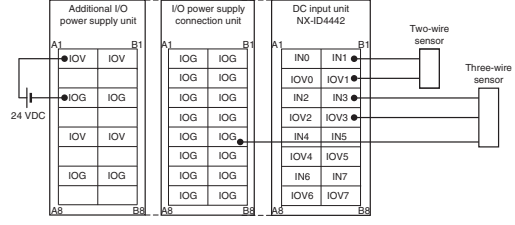

NX-ID5442

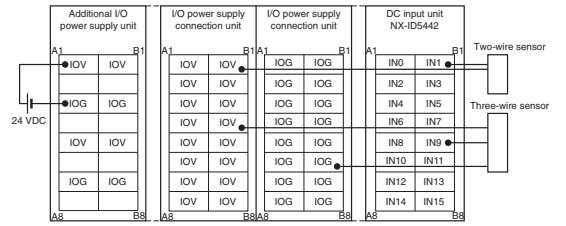

Digital input unit (with time stamp function) (24 VDC)

Item	Specifications	
Model	NX-ID3344	NX-ID3444
Name	DC input unit	
Internal I/O common	NPN	PNP
Capacity	4 points	4 points
Rated input voltage	24 VDC (15 to 28.8 VDC)	
Input current <sup>*1</sup>	3.5 mA	
ON voltage	15 VDC min.	
ON current	3 mA min.	
OFF voltage	5 VDC max.	
OFF current	1 mA max.	
ON/OFF response time	100 ns max.	
Input filter time	No filter	
Dielectric strength	510 VAC between isolated circuits for 1 minute at a leakage current of 5 mA max.	
Insulation resistance	20 MΩ min. between isolated circuits (at 100 VDC)	
Isolation method	Digital isolator	
Unit power consumption	0.55 W max.	
I/O power supply method	Supply from the NX bus	
I/O current consumption	30 mA max.	
Current capacity of I/O power supply terminal	0.1 A/terminal max.	
I/O refreshing method	Time stamp	
Terminal block type	Screwless push-in terminal 12 terminals (A + B)	
Dimensions (W x H x D)	12 x 100 x 71 mm	
Weight	65 g max.	
Disconnection/short-circuit detection	Not supported	
Protective function	Not supported	

\*1. Typical rated current at 24 VDC.

Circuit layout

NX-ID3344

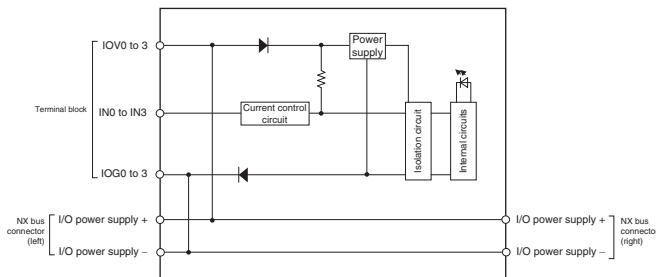

NX-ID3444

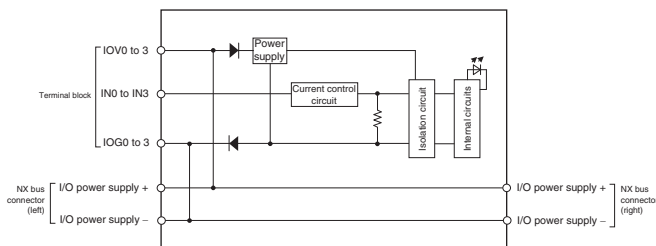

Terminal wiring

NX-ID3344

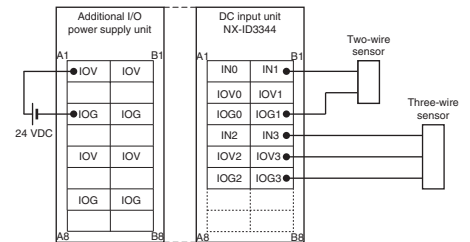

NX-ID3444

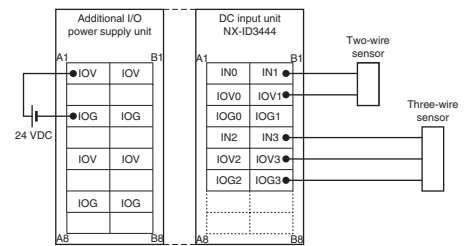

## Digital input unit (with MIL connector) (24 VDC)

Item	Specifications	
Model	<b>NX-ID5142-5</b>	<b>NX-ID6142-5</b>
Name	DC input unit	
Internal I/O common	For both NPN/PNP	
Capacity	16 points	32 points
Rated input voltage	24 VDC (15 to 28.8 VDC)	24 VDC (19 to 28.8 VDC)
Input current <sup>*1</sup>	7 mA	4.1 mA
ON voltage	15 VDC min.	19 VDC min.
ON current	3 mA min.	
OFF voltage	5 VDC max.	
OFF current	1 mA max.	
ON/OFF response time	20 μs max./400 μs max	
Input filter time	No filter, 0.25 ms, 0.5 ms, 1 ms (default), 2 ms, 4 ms, 8 ms, 16 ms, 32 ms, 64 ms, 128 ms, 256 ms	
Dielectric strength	510 VAC between isolated circuits for 1 minute at a leakage current of 5 mA max.	
Insulation resistance	20 MΩ min. between isolated circuits (at 100 VDC)	
Isolation method	Photocoupler isolation	
Unit power consumption	0.55 W max.	0.60 W max.
I/O power supply method	Supply from external source	
I/O current consumption	No consumption	
Current capacity of I/O power supply terminal	Without I/O power supply terminals	
I/O refreshing method	Switching synchronous I/O refreshing and free-run refreshing	
Terminal block type	MIL connector 20 terminals	MIL connector 40 terminals
Dimensions (W x H x D)	30 x 100 x 71 mm	
Weight	85 g max.	90 g max.
Disconnection/ short-circuit detection	Not supported	
Protective function	Not supported	

\*1. Typical rated current at 24 VDC.

### Circuit layout

#### NX-ID5142-5

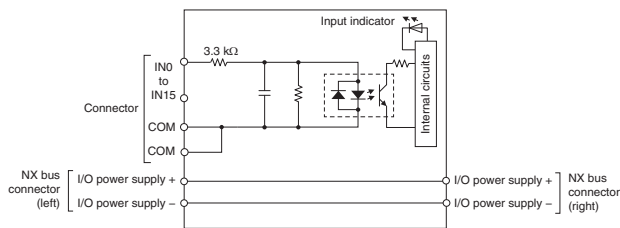

### Terminal wiring

#### NX-ID5142-5

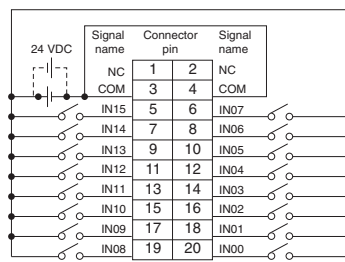

- The polarity of the input power supply can be connected in either direction.
- Be sure to wire both pins 3 and 4 (COM), and set the same polarity for both pins.

#### NX-ID6142-5

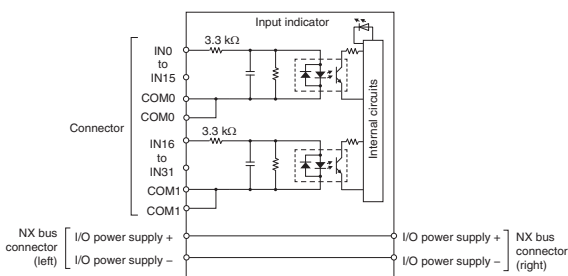

#### NX-ID6142-5

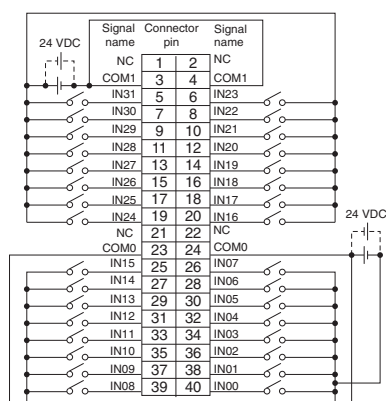

- The polarity of the input power supply can be connected in either direction.
- Be sure to wire both pins 23 and 24 (COM0), and set the same polarity for both pins.
- Be sure to wire both pins 3 and 4 (COM1), and set the same polarity for both pins.

Digital input unit (with M3 screw terminal block) (24 VDC)

Item	Specifications
Model	NX-ID5142-1
Name	DC input unit
Internal I/O common	For both NPN/PNP
Capacity	16 points
Rated input voltage	24 VDC (15 to 28.8 VDC)
Input current <sup>*1</sup>	7 mA
ON voltage	15 VDC min.
ON current	3 mA min.
OFF voltage	5 VDC max.
OFF current	1 mA max.
ON/OFF response time	20 μs max./400 μs max
Input filter time	No filter, 0.25 ms, 0.5 ms, 1 ms (default), 2 ms, 4 ms, 8 ms, 16 ms, 32 ms, 64 ms, 128 ms, 256 ms
Dielectric strength	510 VAC between isolated circuits for 1 minute at a leakage current of 5 mA max.
Insulation resistance	20 MΩ min. between isolated circuits (at 100 VDC)
Isolation method	Photocoupler isolation
Unit power consumption	0.55 W max.
I/O power supply method	Supply from external source
I/O current consumption	No consumption
Current capacity of I/O power supply terminal	Without I/O power supply terminals
I/O refreshing method	Switching synchronous I/O refreshing and free-run refreshing
Terminal block type	M3 screw terminal block 18 terminals
Dimensions (W x H x D)	30 x 100 x 71 mm
Weight	125 g max.
Disconnection/ short-circuit detection	Not supported
Protective function	Not supported

\*1. Typical rated current at 24 VDC.

Circuit layout

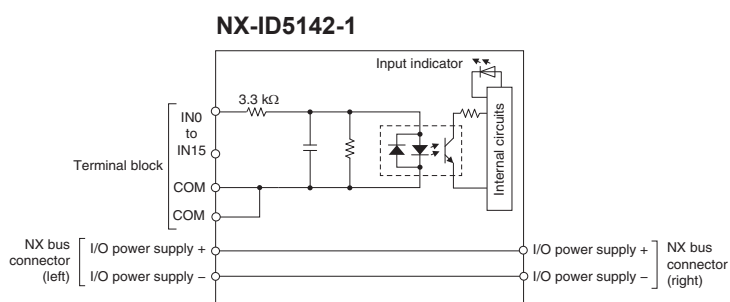

Terminal wiring

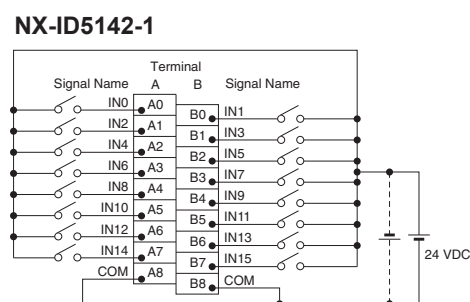

• The polarity of the input power supply can be connected in either direction.

## Digital input unit (with Fujitsu connector) (24 VDC)

Item	Specifications
<b>Model</b>	<b>NX-ID6142-6</b>
<b>Name</b>	DC input unit
<b>Internal I/O common</b>	For both NPN/PNP
<b>Capacity</b>	32 points
<b>Rated input voltage</b>	24 VDC (19 to 28.8 VDC)
<b>Input current<sup>*1</sup></b>	4.1 mA
<b>ON voltage</b>	19 VDC min.
<b>ON current</b>	3 mA min.
<b>OFF voltage</b>	5 VDC max.
<b>OFF current</b>	1 mA max.
<b>ON/OFF response time</b>	20 μs max./400 μs max
<b>Input filter time</b>	No filter, 0.25 ms, 0.5 ms, 1 ms (default), 2 ms, 4 ms, 8 ms, 16 ms, 32 ms, 64 ms, 128 ms, 256 ms
<b>Dielectric strength</b>	510 VAC between isolated circuits for 1 minute at a leakage current of 5 mA max.
<b>Insulation resistance</b>	20 MΩ min. between isolated circuits (at 100 VDC)
<b>Isolation method</b>	Photocoupler isolation
<b>Unit power consumption</b>	0.55 W max.
<b>I/O power supply method</b>	Supply from external source
<b>I/O current consumption</b>	No consumption
<b>Current capacity of I/O power supply terminal</b>	Without I/O power supply terminals
<b>I/O refreshing method</b>	Switching synchronous I/O refreshing and free-run refreshing
<b>Terminal block type</b>	Fujitsu connector 40 terminals
<b>Dimensions (W x H x D)</b>	30 x 100 x 71 mm
<b>Weight</b>	90 g max.
<b>Disconnection/short-circuit detection</b>	Not supported
<b>Protective function</b>	Not supported

\*1. Typical rated current at 24 VDC.

### Circuit layout

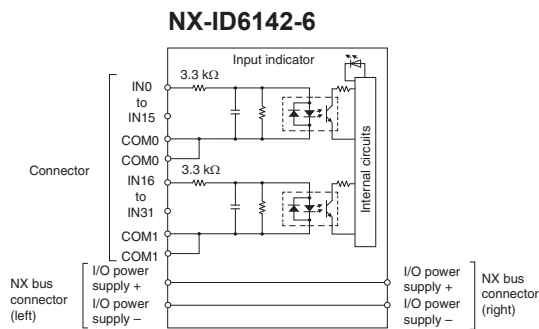

### Terminal wiring

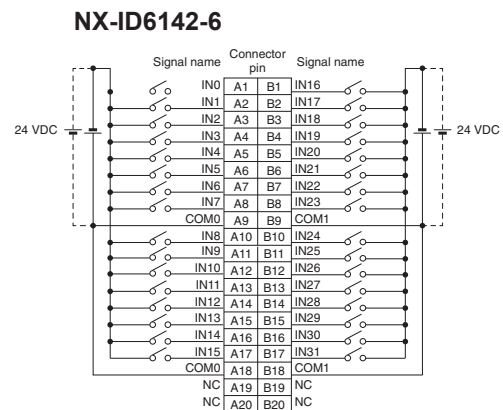

- The polarity of the input power supply can be connected in either direction.
- Be sure to wire both pins A9 and A18 (COM0), and set the same polarity for both pins.
- Be sure to wire both pins B9 and B18 (COM1), and set the same polarity for both pins.

Digital input unit (230 VAC)

Item	Specifications
Model	NX-IA3117
Name	AC input unit
Internal I/O common	No polarity
Capacity	4 points, independent contacts
Rated input voltage	200 to 240 VAC, 50/60 Hz (170 to 264 VAC, ±3 Hz)
Input current	9 mA (at 200 VAC, 50 Hz) 11 mA (at 200 VAC, 60 Hz)
ON voltage	120 VAC min.
ON current	4 mA min.
OFF voltage	40 VAC max.
OFF current	2 mA max.
ON/OFF response time	10 ms max./40 ms max.
Input filter time	Default setting: 1 ms <sup>-1</sup>
Dielectric strength	Between each AC input circuit: AC3700V VAC for 1 min at a leakage current of 5 mA max. Between the external terminals and functional ground terminal: 2300 VAC for 1 min at a leakage current of 5 mA max. Between the external terminals and internal circuits: 2300 VAC for 1 min at a leakage current of 5 mA max. Between the internal circuit and the functional ground terminal: 510 VAC for 1 min at a leakage current of 5 mA max.
Insulation resistance	Between each AC input circuit: 20 MΩ min. (at 500 VDC) Between the external terminals and functional ground terminal: 20 MΩ min. (at 500 VDC) Between the external terminals and internal circuits: 20 MΩ min. (at 500 VDC) Between the internal circuit and the functional ground terminal: 20 MΩ min. (at 100 VDC)
Isolation method	Photocoupler isolation
Unit power consumption	0.5 W max.
I/O power supply method	Supply from external source
I/O current consumption	No consumption
Current capacity of I/O power supply terminal	Without I/O power supply terminals
I/O refreshing method	Free-run refreshing
Terminal block type	Screwless push-in terminal 8 terminals (A + B)
Dimensions (W x H x D)	12 x 100 x 71 mm
Weight	60 g max.
Disconnection/short-circuit detection	Not supported
Protective function	Not supported

\*1. Input filter time: No filter, 0.25, 0.5, 1, 2, 4, 8, 16, 32, 64, 128, 256 ms.

Circuit layout

NX-IA3117

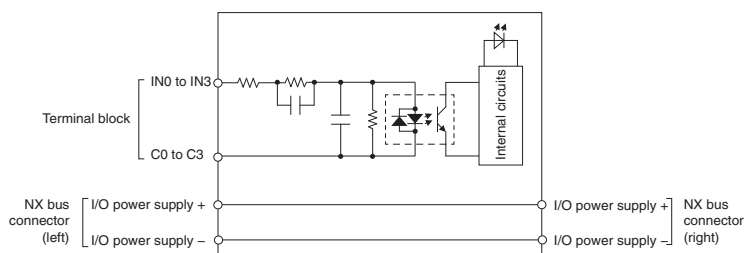

Terminal wiring

NX-IA3117

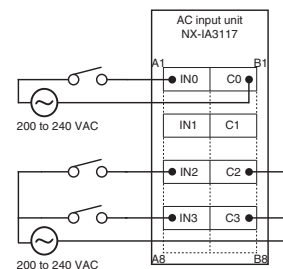

## Digital output unit

Item	Specifications										
Model	NX-OD3121	NX-OD4121	NX-OD5121	NX-OD3153	NX-OD3256	NX-OD4256	NX-OD5256	NX-OD3268	NX-OD3257		
Name	Transistor output unit										
Internal I/O common	NPN					PNP					
Capacity	4 points	8 points	16 points	4 points	4 points	8 points	16 points	4 points	4 points		
Rated voltage	12 to 24 VDC			24 VDC							
Operating load voltage	10.2 to 28.8 VDC			15 to 28.8 VDC							
Maximum value of load current	0.5 A/point, 2 A/NX unit	0.5 A/point, 4 A/NX unit		0.5 A/point, 2 A/NX unit	0.5 A/point, 2 A/NX unit	0.5 A/point, 4 A/NX unit		2 A/point, 8 A/NX unit	0.5 A/point, 2 A/NX unit		
Maximum inrush current	4.0 A/point, 10 ms max.										
Leakage current	0.1 mA max.										
Residual voltage	1.5 V max.										
ON/OFF response time	0.1 ms max./0.8 ms max.			300 ns max.	0.5 ms max./1.0 ms max.				300 ns max.		
Dielectric strength	510 VAC between isolated circuits for 1 minute at a leakage current of 5 mA max.										
Insulation resistance	20 MΩ min. between isolated circuits (at 100 VDC)										
Isolation method	Photocoupler isolation			Digital isolator	Photocoupler isolation					Digital isolator	
Unit power consumption	0.55 W max.	0.55 W max.	0.65 W max.	0.50 W max.	0.55 W max.	0.65 W max.	0.70 W max.	0.50 W max.	0.50 W max.		
I/O power supply method	Supply from the NX bus							Supply from external source	Supply from the NX bus		
I/O current consumption	10 mA max.	10 mA max.	20 mA max.	30 mA max.	20 mA max.	30 mA max.	40 mA max.	20 mA max.	40 mA max.		
Current capacity of I/O power supply terminal	0.5 A/terminal max.		Without I/O power supply terminals	0.5 A/terminal max.	0.5 A/terminal max.		Without I/O power supply terminals	IOV/IOG: 2 A/terminal max. COM/OV: 4A/terminal max.	0.5 A/terminal max.		
I/O refreshing method	Switching synchronous I/O refreshing and free-run refreshing										
Terminal block type	Screwless push-in terminal 12 terminals (A + B)	Screwless push-in terminal 16 terminals (A + B)	Screwless push-in terminal 16 terminals (A + B)	Screwless push-in terminal 12 terminals (A + B)	Screwless push-in terminal 12 terminals (A + B)	Screwless push-in terminal 16 terminals (A + B)	Screwless push-in terminal 16 terminals (A + B)	Screwless push-in terminal 16 terminals (A + B)	Screwless push-in terminal 16 terminals (A + B)	Screwless push-in terminal 12 terminals (A + B)	
Dimensions (W x H x D)	12 x 100 x 71 mm										
Weight	70 g max.										
Disconnection/short-circuit detection	Not supported										
Protective function	Not supported				With load short-circuit protection						

### Circuit layout

#### NX-OD3121

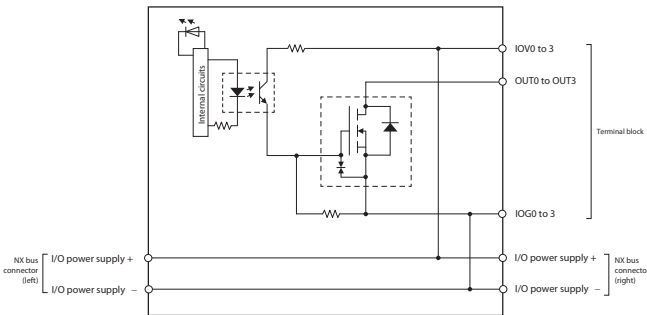

#### NX-OD3153

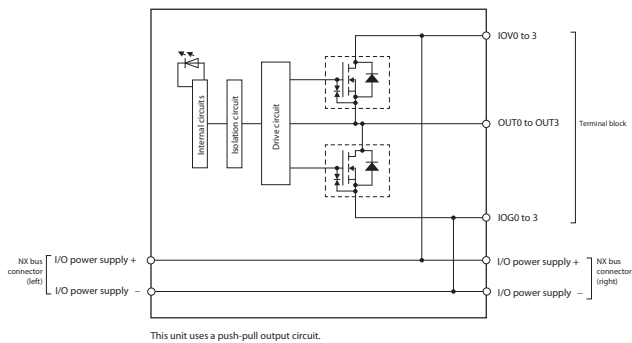

### Terminal wiring

#### NX-OD3121

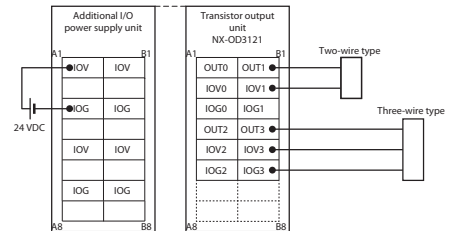

#### NX-OD3153

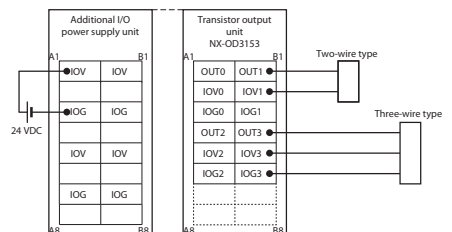

Circuit layout

NX-OD4121

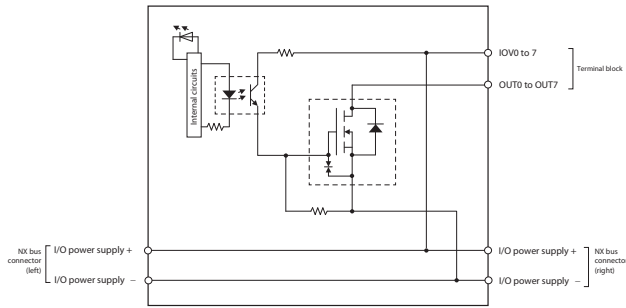

Terminal wiring

NX-OD4121

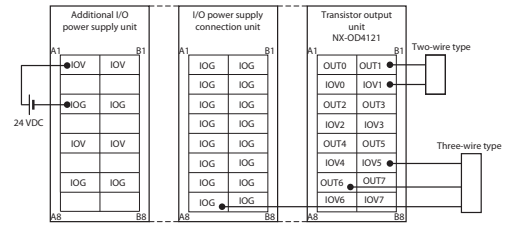

NX-OD5121

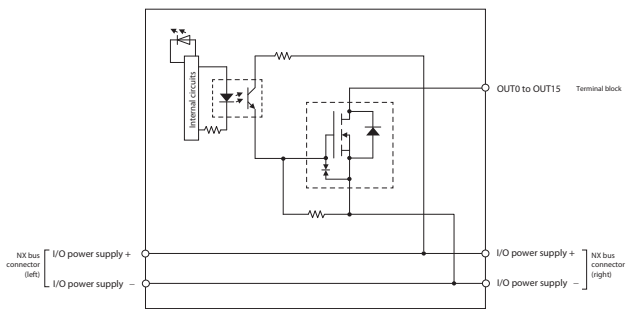

NX-OD5121

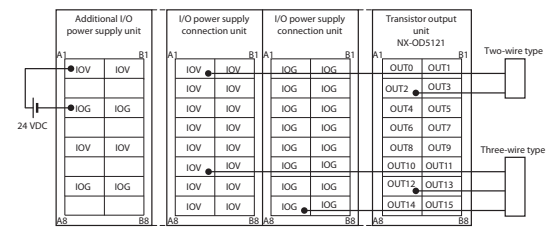

NX-OD3256

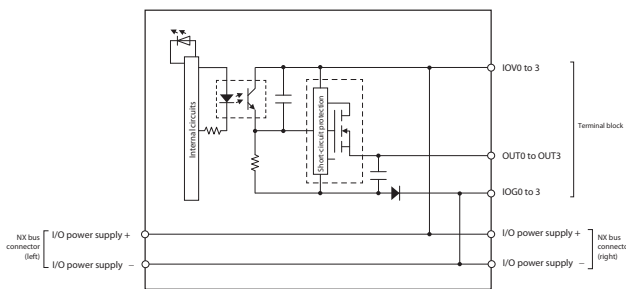

NX-OD3256

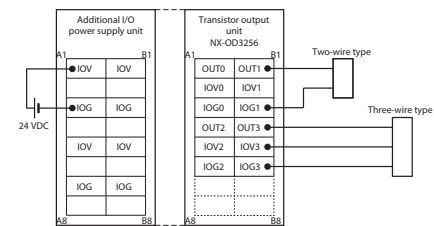

NX-OD3257

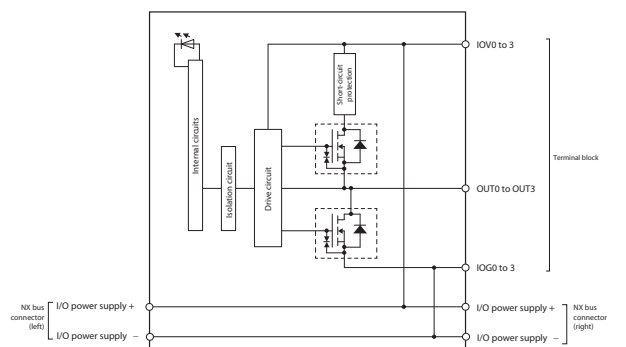

NX-OD3257

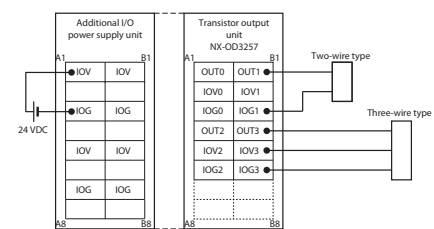

NX-OD4256

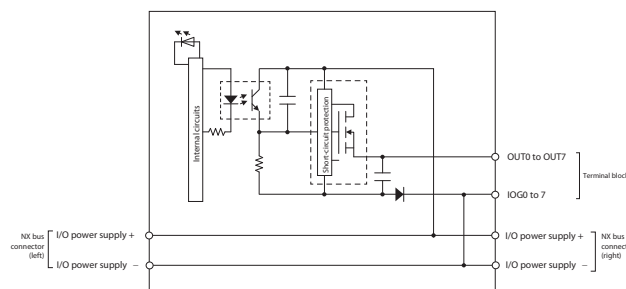

NX-OD4256

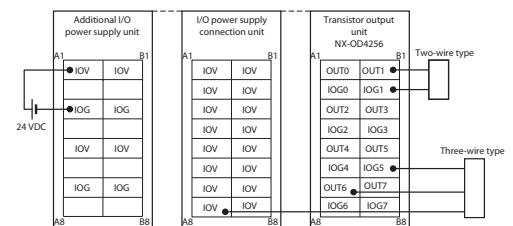

Circuit layout

NX-OD5256

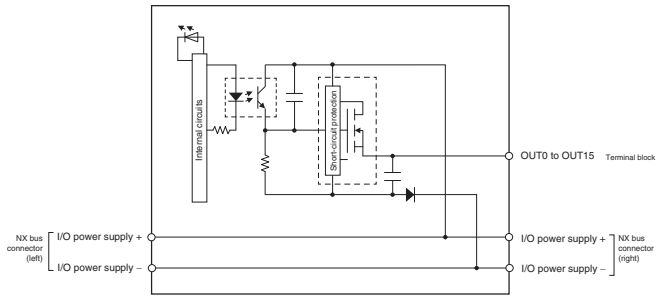

Terminal wiring

NX-OD5256

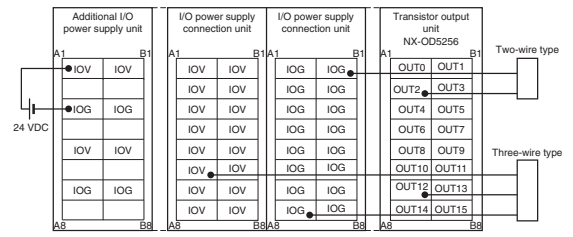

NX-OD3268

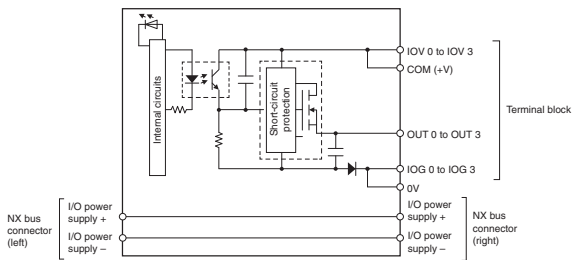

NX-OD3268

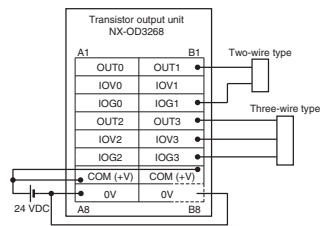

- 0V has 2 terminals, so be sure to wire both terminals.
- COM (+V) has 2 terminals, so be sure to wire both terminals.

Digital output unit (with time stamp function)

Item	Specifications	
Model	NX-OD2154	NX-OD2258
Name	Transistor output unit	
Internal I/O common	NPN	PNP
Capacity	2 points	2 points
Rated voltage	24 VDC	
Operating load voltage	15 to 28.8 VDC	
Maximum value of load current	0.5 A/point, 1 A/NX unit	
Maximum inrush current	4.0 A/point, 10 ms max.	
Leakage current	0.1 mA max.	
Residual voltage	1.5 V max.	
ON/OFF response time	300 ns max.	
Dielectric strength	510 VAC between isolated circuits for 1 minute at a leakage current of 5 mA max.	
Insulation resistance	20 MΩ min. between isolated circuits (at 100 VDC)	
Isolation method	Digital isolator	
Unit power consumption	0.50 W max.	
I/O power supply method	Supply from the NX bus	
I/O current consumption		40 mA max.
Current capacity of I/O power supply terminal	0.5 A/terminal max.	
I/O refreshing method	Time Stamp	
Terminal block type	Screwless push-in terminal 8 terminals (A + B)	
Dimensions (W x H x D)	12 x 100 x 71 mm	
Weight	70 g max.	
Disconnection/short-circuit detection	Not supported	
Protective function	Not supported	With load short-circuit protection

Circuit layout

NX-OD2154

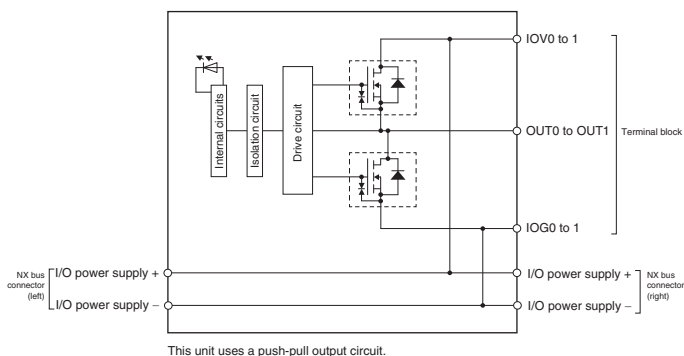

Terminal wiring

NX-OD2154

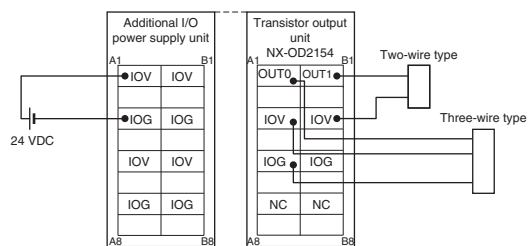

NX-OD2258

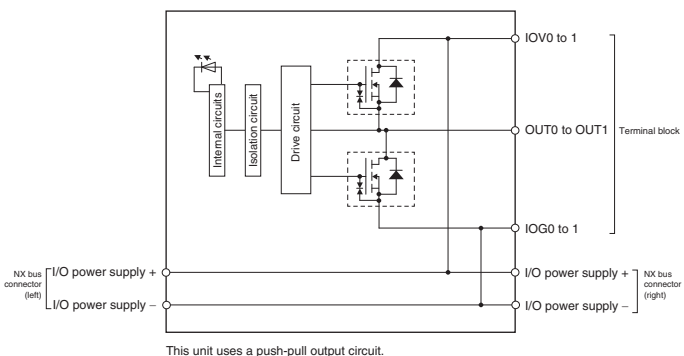

NX-OD2258

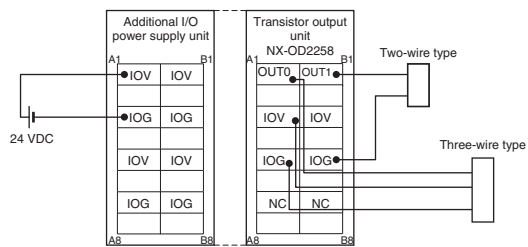

## Digital output unit (with MIL connector)

Item	Specifications			
Model	NX-OD5121-5	NX-OD5256-5	NX-OD6121-5	NX-OD6256-5
Name	Transistor output unit			
Internal I/O common	NPN	PNP	NPN	PNP
Capacity	16 points	16 points	32 points	32 points
Rated voltage	12 to 24 VDC	24 VDC	12 to 24 VDC	24 VDC
Operating load voltage	10.2 to 28.8 VDC	20.4 to 28.8 VDC	10.2 to 28.8 VDC	20.4 to 28.8 VDC
Maximum value of load current	0.5 A/point, 2 A/NX unit		0.5 A/point, 2 A/common, 4 A/NX unit	
Maximum inrush current	4.0 A/point, 10 ms max.			
Leakage current	0.1 mA max.			
Residual voltage	1.5 V max.			
ON/OFF response time	0.1 ms max./0.8 ms max.	0.5 ms max./1.0 ms max.	0.1 ms max./0.8 ms max.	0.5 ms max./1.0 ms max.
Dielectric strength	510 VAC between isolated circuits for 1 minute at a leakage current of 5 mA max.			
Insulation resistance	20 MΩ min. between isolated circuits (at 100 VDC)			
Isolation method	Photocoupler isolation			
Unit power consumption	0.60 W max.	0.70 W max.	0.80 W max.	1.0 W max.
I/O power supply method	Supply from external source			
I/O current consumption	30 mA max.	40 mA max.	50 mA max.	80 mA max.
Current capacity of I/O power supply terminal	Without I/O power supply terminals			
I/O refreshing method	Switching synchronous I/O refreshing and free-run refreshing			
Terminal block type	MIL connector 20 terminals		MIL connector 40 terminals	
Dimensions (W x H x D)	30 x 100 x 71 mm			
Weight	80 g max.	85 g max.	90 g max.	95 g max.
Disconnection/short-circuit detection	Not supported			
Protective function	Not supported	With load short-circuit protection	Not supported	With load short-circuit protection

### Circuit layout

#### NX-OD5121-5

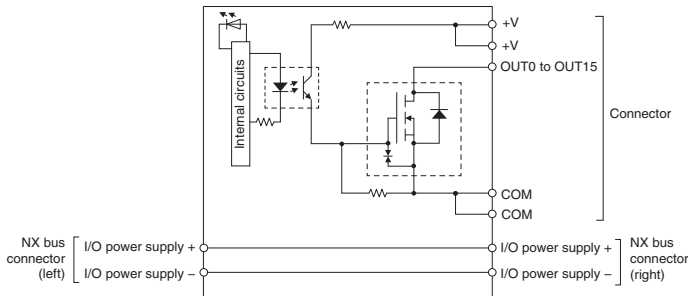

#### NX-OD5256-5

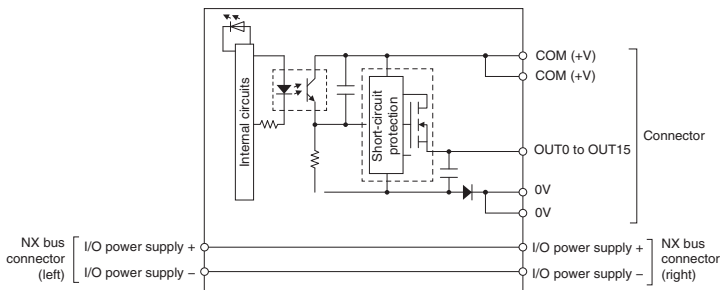

### Terminal wiring

#### NX-OD5121-5

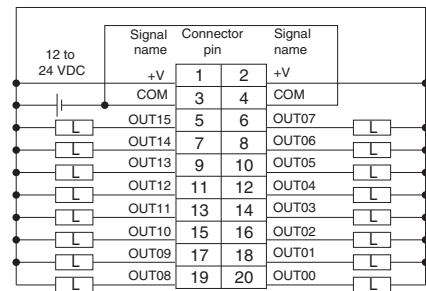

- Be sure to wire both pins 3 and 4 (COM).
- Be sure to wire both pins 1 and 2 (+V).

#### NX-OD5256-5

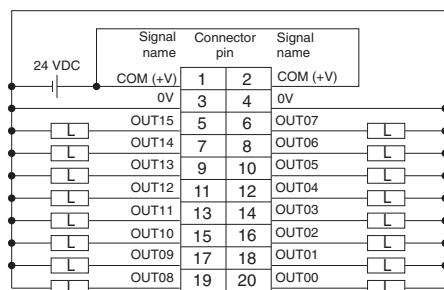

- Be sure to wire both pins 1 and 2 (COM (+V)).
- Be sure to wire both pins 3 and 4 (0V).

Circuit layout

NX-OD6121-5

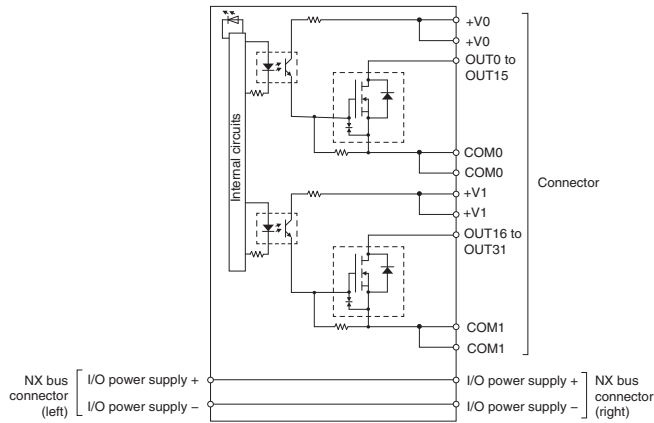

Terminal wiring

NX-OD6121-5

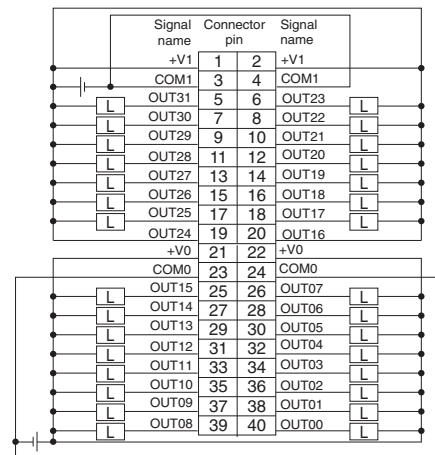

- Be sure to wire both pins 21 and 22 (+V0).
- Be sure to wire both pins 23 and 24 (COM0).
- Be sure to wire both pins 1 and 2 (+V1).
- Be sure to wire both pins 3 and 4 (COM1).

NX-OD6256-5

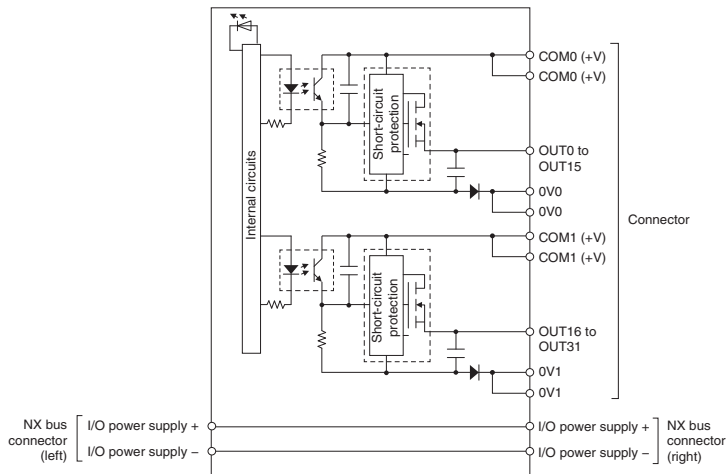

NX-OD6256-5

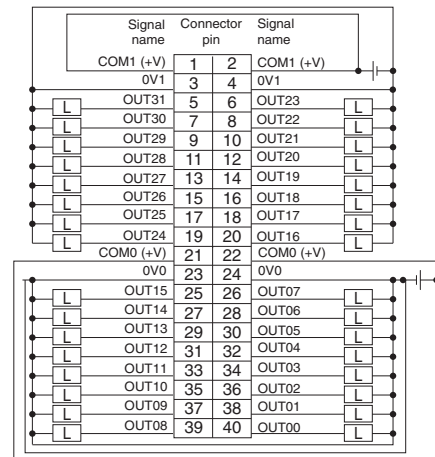

- Be sure to wire both pins 21 and 22 (COM0 (+V)).
- Be sure to wire both pins 1 and 2 (COM1 (+V)).
- Be sure to wire both pins 23 and 24 (0V0).
- Be sure to wire both pins 3 and 4 (0V1).

## Digital output unit (with M3 screw terminal block)

Item	Specifications	
Model	<b>NX-OD5121-1</b>	<b>NX-OD5256-1</b>
Name	Transistor output unit	
Internal I/O common	NPN	PNP
Capacity	16 points	16 points
Rated voltage	12 to 24 VDC	24 VDC
Operating load voltage	10.2 to 28.8 VDC	20.4 to 28.8 VDC
Maximum value of load current	0.5 A/point, 5 A/NX unit	
Maximum inrush current	4.0 A/point, 10 ms max.	
Leakage current	0.1 mA max.	
Residual voltage	1.5 V max.	
ON/OFF response time	0.1 ms max./0.8 ms max.	0.5 ms max./1.0 ms max.
Dielectric strength	510 VAC between isolated circuits for 1 minute at a leakage current of 5 mA max.	
Insulation resistance	20 MΩ min. between isolated circuits (at 100 VDC)	
Isolation method	Photocoupler isolation	
Unit power consumption	0.60 W max.	0.65 W max.
I/O power supply method	Supply from external source	
I/O current consumption	30 mA max.	
Current capacity of I/O power supply terminal	Without I/O power supply terminals	
I/O refreshing method	Switching synchronous I/O refreshing and free-run refreshing	
Terminal block type	M3 screw terminal block 18 terminals	
Dimensions (W x H x D)	30 x 100 x 71 mm	
Weight	125 g max.	
Disconnection/short-circuit detection	Not supported	
Protective function	Not supported	With load short-circuit protection

### Circuit layout

#### NX-OD5121-1

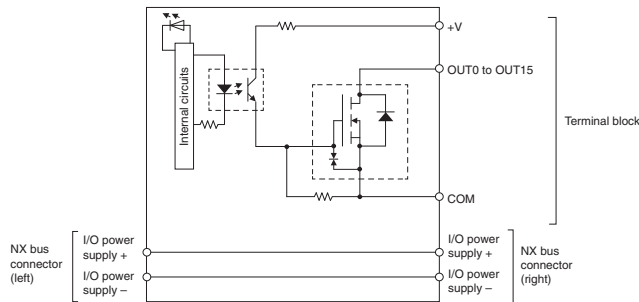

### Terminal wiring

#### NX-OD5121-1

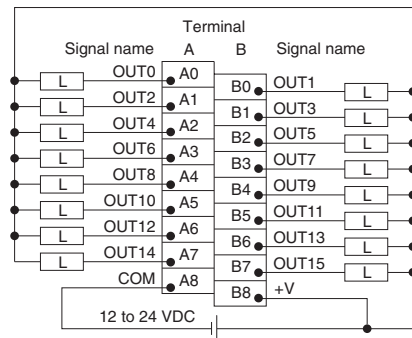

#### NX-OD5256-1

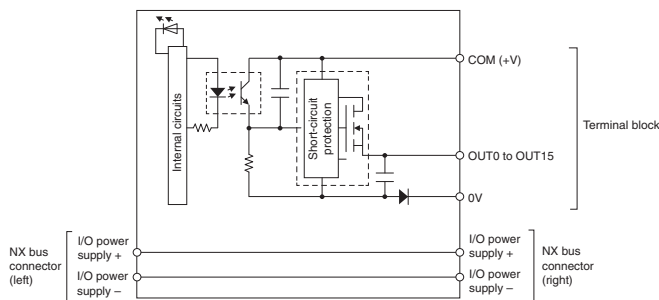

#### NX-OD5256-1

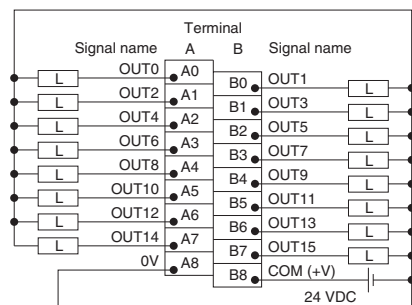

Digital output unit (with Fujitsu connector)

Item	Specifications
Model	NX-OD6121-6
Name	Transistor output unit
Internal I/O common	NPN
Capacity	32 points
Rated voltage	12 to 24 VDC
Operating load voltage	10.2 to 28.8 VDC
Maximum value of load current	0.5 A/point, 2 A/common, 4 A/NX unit
Maximum inrush current	4.0 A/point, 10 ms max.
Leakage current	0.1 mA max.
Residual voltage	1.5 V max.
ON/OFF response time	0.1 ms max./0.8 ms max.
Dielectric strength	510 VAC between isolated circuits for 1 minute at a leakage current of 5 mA max.
Insulation resistance	20 MΩ min. between isolated circuits (at 100 VDC)
Isolation method	Photocoupler isolation
Unit power consumption	0.80 W max.
I/O power supply method	Supply from external source
I/O current consumption	50 mA max.
Current capacity of I/O power supply terminal	Without I/O power supply terminals
I/O refreshing method	Switching synchronous I/O refreshing and free-run refreshing
Terminal block type	Fujitsu connector 40 terminals
Dimensions (W x H x D)	30 x 100 x 71 mm
Weight	90 g max.
Disconnection/short-circuit detection	Not supported
Protective function	Not supported

Circuit layout

NX-OD6121-6

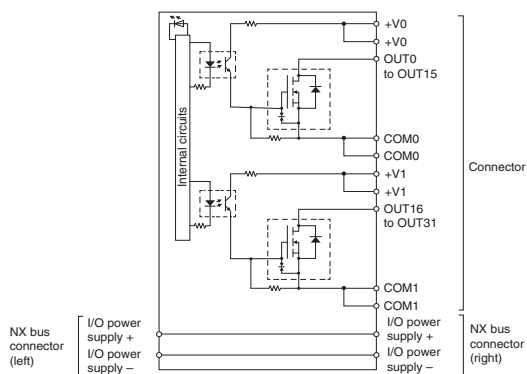

Terminal wiring

NX-OD6121-6

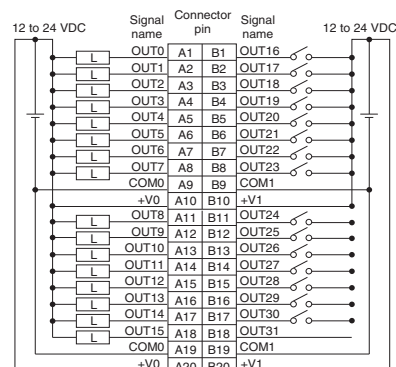

- Be sure to wire both pins A9 and A19 (COM0).
- Be sure to wire both pins B9 and B19 (COM1).
- Be sure to wire both pins A10 and A20 (+V0).
- Be sure to wire both pins B10 and B20 (+V1).

## Relay output unit

Item	Specifications		
Model	NX-OC2633	NX-OC2733	NX-OC4633
Name	Relay output unit		
Relay type	N.O. contact	N.O. + N.C. contact	N.O. contact
Capacity	2 points, independent contacts		8 points, independent contacts
Max. switching capacity	250 VAC/2 A (cos $\phi$ = 1), 250 VAC/2 A (cos $\phi$ = 0.4), 24 VDC/2 A, 4 A/unit		250 VAC/2 A (cos $\phi$ = 1), 250 VAC/2 A (cos $\phi$ = 0.4), 24 VDC/2 A, 8 A/unit
Min. switching capacity	5 VDC, 1 mA		
ON/OFF response time	15 ms max.		
Relay service life	Electrical: 100,000 operations <sup>*1</sup> Mechanical: 20,000,000 operations		
Dielectric strength	Between A1/B1 terminals and A3/B3 terminals: 2,300 VAC for 1 min at a leakage current of 5 mA max. Between the external terminals and GR terminal: 2,300 VAC for 1 min at a leakage current of 5 mA max. Between the external terminals and internal circuits: 2,300 VAC for 1 min at a leakage current of 5 mA max. Between the internal circuit and GR terminal: 510 VAC for 1 min at a leakage current of 5 mA max.	Between A1/3, B1/3 terminals and A5/7, B5/7 terminals: 2,300 VAC for 1 min at a leakage current of 5 mA max. Between the external terminals and functional ground terminal: 2,300 VAC for 1 min at a leakage current of 5 mA max. Between the external terminals and internal circuits: 2,300 VAC for 1 min at a leakage current of 5 mA max. Between the internal circuit and functional ground terminal: 510 VAC for 1 min at a leakage current of 5 mA max.	Between output bits: 2,300 VAC for 1 min at a leakage current of 5 mA max. Between the external terminals and the functional ground terminal: 2,300 VAC for 1 min at a leakage current of 5 mA max. Between the external terminals and internal circuits: 2,300 VAC for 1 min at a leakage current of 5 mA max. Between the internal circuit and functional ground terminal: 510 VAC for 1 min at a leakage current of 5 mA max.
Insulation resistance	Between A1/B1 terminals and A3/B3 terminals: 20 M $\Omega$ min. (500 VDC) Between the external terminals and internal circuits: 20 M $\Omega$ min. (500 VDC) Between the internal circuit and GR terminal: 20 M $\Omega$ min. (100 VDC) Between the external terminals and GR terminal: 20 M $\Omega$ min. (500 VDC)	Between A1/3, B1/3 terminals and A5/7, B5/7 terminals: 20 M $\Omega$ min. (500 VDC) Between the external terminals and functional ground terminal: 20 M $\Omega$ min. (500 VDC) Between the external terminals and internal circuits: 20 M $\Omega$ min. (500 VDC) Between the internal circuit and functional ground terminal: 20 M $\Omega$ min. (100 VDC)	Between output bits: 20 M $\Omega$ min. (500 VDC) Between the external terminals and the functional ground terminal: 20 M $\Omega$ min. (500 VDC) Between the external terminals and internal circuits: 20 M $\Omega$ min. (500 VDC) Between the internal circuit and functional ground terminal: 20 M $\Omega$ min. (100 VDC)
Vibration resistance	Conforms to IEC60068-2-6. 5 to 8.4 Hz with amplitude of 3.5 mm, 8.4 to 150 Hz, acceleration of 9.8 m/s <sup>2</sup> , 100 min each in X, Y and Z directions (10 sweeps of 10 min each = 100 min total)		
Shock resistance	100 m/s <sup>2</sup> , 3 times each in X, Y and Z directions		
Isolation method	Relay isolation		
Unit power consumption	0.80 W max.	0.95 W max.	1.65 W max.
I/O power supply method	Supply from external source		
I/O current consumption	No consumption		
Current capacity of I/O power supply terminal	Without I/O power supply terminals		
I/O refreshing method	Free-run refreshing		
Terminal block type	Screwless push-in terminal 8 terminals (A + B)		Screwless push-in terminal 8 terminals $\times$ 2 (A + B)
Dimensions (W x H x D)	12 x 100 x 71 mm		24 x 100 x 71 mm
Weight	65 g max.	70 g max.	140 g max.
Disconnection/short-circuit detection	Not supported		
Protective function	Not supported		

\*1. Electrical service life will vary depending on the current value. Refer to "NX-series digital I/O units user's manual" for details.

**Circuit layout**

**NX-OC2633**

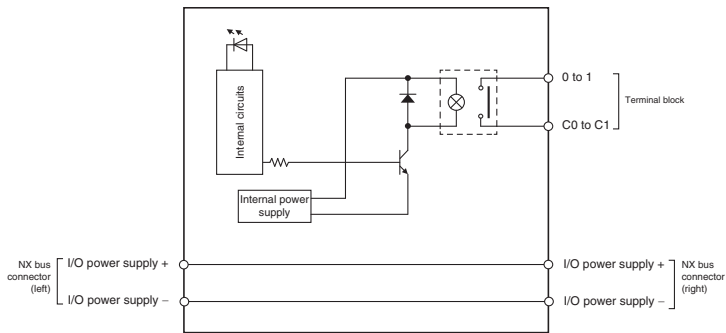

You cannot replace the relay.

**Terminal wiring**

**NX-OC2633**

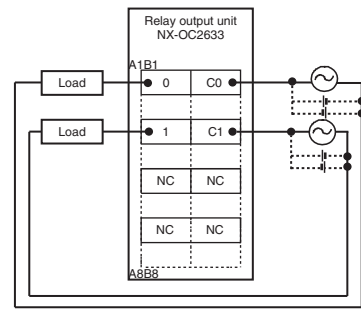

**NX-OC2733**

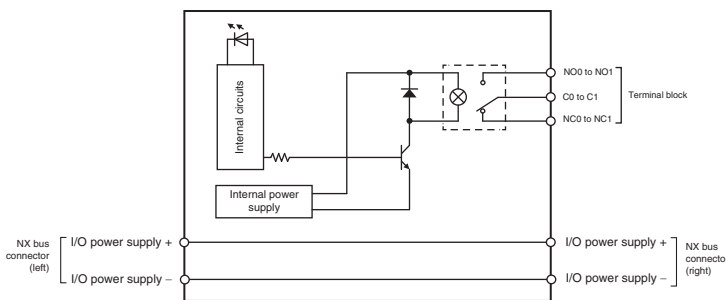

NO0 and NO1 are normal open contacts, and NC0 and NC1 are normal close contacts. You cannot replace the relay.

**NX-OC2733**

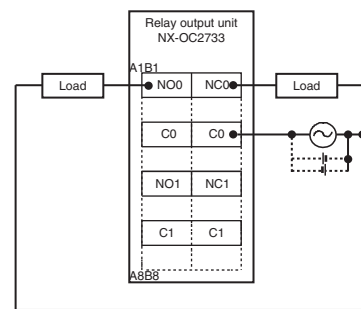

**NX-OC4633**

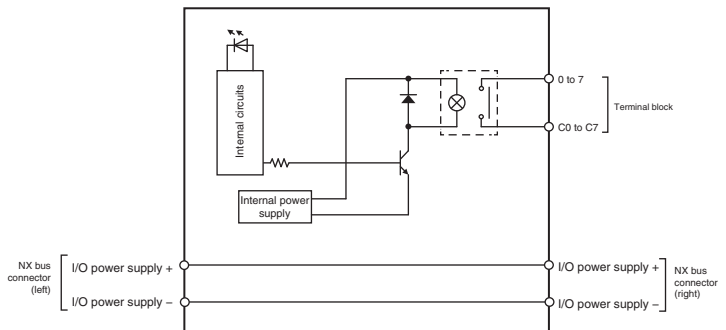

You cannot replace the relay.

**NX-OC4633**

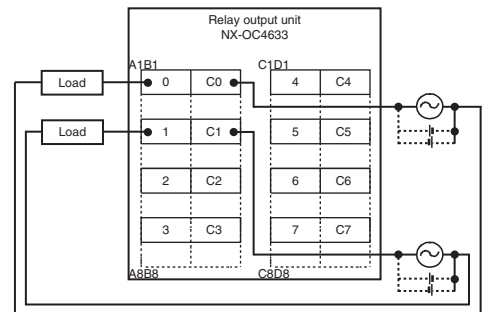

## Digital I/O unit (with MIL connector)

Item	Specifications		
Model	<b>NX-MD6121-5</b>	<b>NX-MD6256-5</b>	
Name	DC input/transistor output unit		
Capacity	16 inputs/16 outputs		
Output section (CN1)	Internal I/O common	NPN	PNP
	Rated voltage	12 to 24 VDC	24 VDC
	Operating load voltage	10.2 to 28.8 VDC	20.4 to 28.8 VDC
	Maximum value of load current	0.5 A/point, 2 A/NX unit	
	Maximum inrush current	4.0 A/point, 10 ms max.	
	Leakage current	0.1 mA max.	
	Residual voltage	1.5 V max.	
	ON/OFF response time	0.1 ms max./0.8 ms max.	0.5 ms max./1.0 ms max.
Input section (CN2)	Internal I/O common	For both NPN/PNP	
	Rated input voltage	24 VDC (15 to 28.8 VDC)	
	Input current <sup>1</sup>	7 mA	
	ON voltage	15 VDC min.	
	ON current	3 mA min.	
	OFF voltage	5 VDC max.	
	OFF current	1 mA max.	
	ON/OFF response time	20 μs max./400 μs max	
Input filter time	No filter, 0.25 ms, 0.5 ms, 1 ms (default), 2 ms, 4 ms, 8 ms, 16 ms, 32 ms, 64 ms, 128 ms, 256 ms		
Dielectric strength	510 VAC between isolated circuits for 1 minute at a leakage current of 5 mA max.		
Insulation resistance	20 MΩ min. between isolated circuits (at 100 VDC)		
Isolation method	Photocoupler isolation		
Unit power consumption	0.70 W max.	0.75 W max.	
I/O power supply method	Supply from external source		
I/O current consumption	30 mA max.	40 mA max.	
Current capacity of I/O power supply terminal	Without I/O power supply terminals		
I/O refreshing method	Switching synchronous I/O refreshing and free-run refreshing		
Terminal block type	2 MIL connectors 20 terminals		
Dimensions (W x H x D)	30 x 100 x 71 mm		
Weight	105 g max.	110 g max.	
Disconnection/short-circuit detection	Not supported		
Protective function	Not supported	With load short-circuit protection	

\*1. Typical rated current at 24 VDC.

### Circuit layout

#### NX-MD6121-5 CN1 (left) output circuit

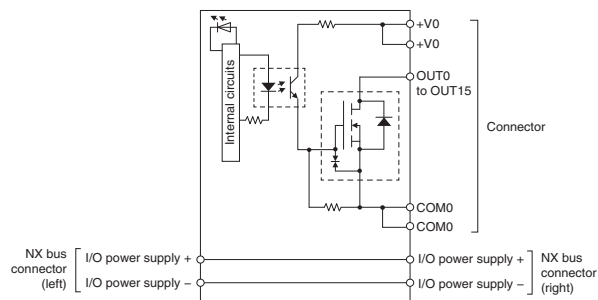

### Terminal wiring

#### NX-MD6121-5 CN1 (left) output terminal

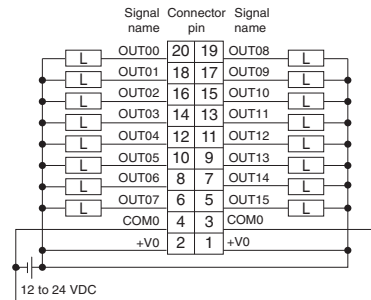

- Be sure to wire both pins 3 and 4 (COM0) of CN1.
- Be sure to wire both pins 1 and 2 (+V0) of CN1.

#### CN2 (right) input circuit

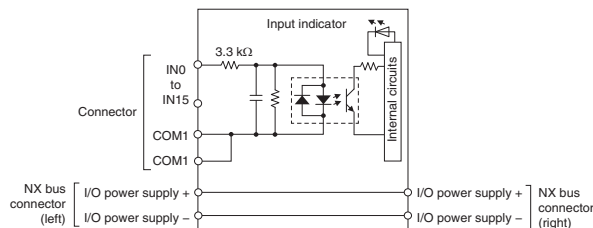

#### CN2 (right) input terminal

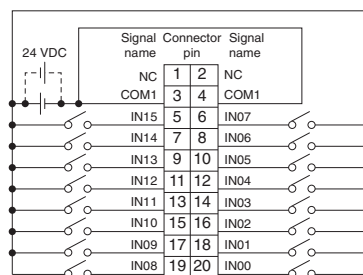

- The polarity of the input power supply of CN2 can be connected in either direction.
- Be sure to wire both pins 3 and 4 (COM1) of CN2, and set the same polarity for both pins.

**Circuit layout**

**NX-MD6256-5  
CN1 (left) output circuit**

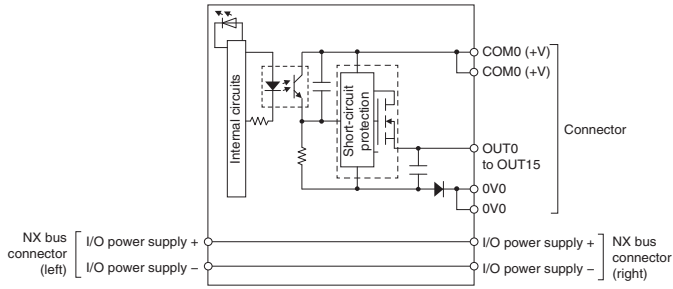

**CN2 (right) input circuit**

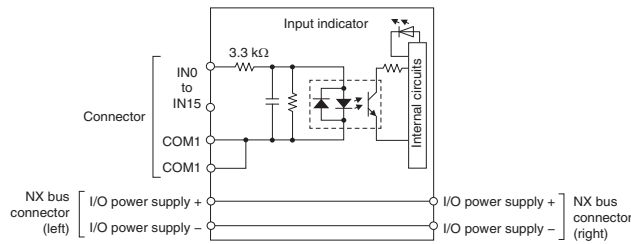

**Terminal wiring**

**NX-MD6256-5  
CN1 (left) output terminal**

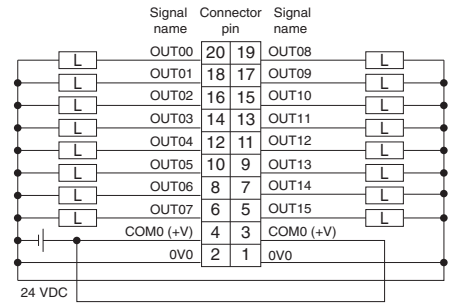

- Be sure to wire both pins 3 and 4 (COM0 (+V)) of CN1.
- Be sure to wire both pins 1 and 2 (0V0) of CN1.

**CN2 (right) input terminal**

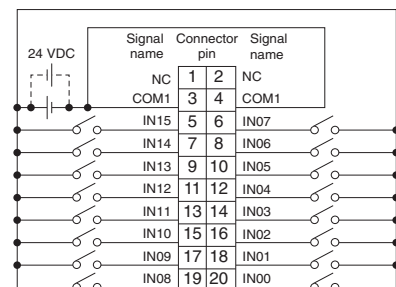

- The polarity of the input power supply of CN2 can be connected in either direction.
- Be sure to wire both pins 3 and 4 (COM1) of CN2, and set the same polarity for both pins.

## Digital I/O unit (with Fujitsu connector)

Item	Specifications	
Model	NX-MD6121-6	
Name	DC input/transistor output unit	
Capacity	16 inputs/16 outputs	
Output section (CN1)	Internal I/O common	NPN
	Rated voltage	12 to 24 VDC
	Operating load voltage	10.2 to 28.8 VDC
	Maximum value of load current	0.5 A/point, 2 A/NX unit
	Maximum inrush current	4.0 A/point, 10 ms max.
	Leakage current	0.1 mA max.
	Residual voltage	1.5 V max.
	ON/OFF response time	0.1 ms max./0.8 ms max.
Input section (CN2)	Internal I/O common	For both NPN/PNP
	Rated input voltage	24 VDC (15 to 28.8 VDC)
	Input current <sup>*1</sup>	7 mA
	ON voltage	15 VDC min.
	ON current	3 mA min.
	OFF voltage	5 VDC max.
	OFF current	1 mA max.
	ON/OFF response time	20 μs max./400 μs max
Input filter time	No filter, 0.25 ms, 0.5 ms, 1 ms (default), 2 ms, 4 ms, 8 ms, 16 ms, 32 ms, 64 ms, 128 ms, 256 ms	
Dielectric strength	510 VAC between isolated circuits for 1 minute at a leakage current of 5 mA max.	
Insulation resistance	20 MΩ min. between isolated circuits (at 100 VDC)	
Isolation method	Photocoupler isolation	
Unit power consumption	0.70 W max.	
I/O power supply method	Supply from external source	
I/O current consumption	30 mA max.	
Current capacity of I/O power supply terminal	Without I/O power supply terminals	
I/O refreshing method	Switching synchronous I/O refreshing and free-run refreshing	
Terminal block type	2 Fujitsu connectors 24 terminals	
Dimensions (W x H x D)	30 x 100 x 71 mm	
Weight	95 g max.	
Disconnection/short-circuit detection	Not supported	
Protective function	Not supported	

\*1. Typical rated current at 24 VDC.

### Circuit layout

#### NX-MD6121-6 CN1 (left) output circuit

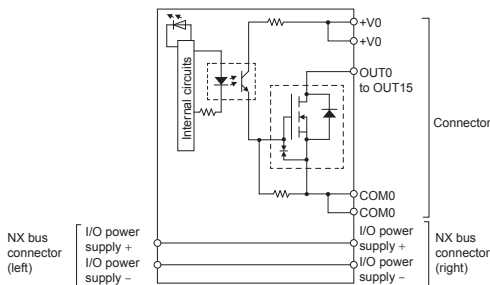

### Terminal wiring

#### NX-MD6121-6 CN1 (left) output terminal

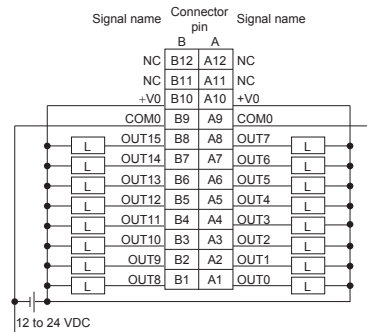

- Be sure to wire both pins A9 and B9 (COM0) of CN1.
- Be sure to wire both pins A10 and B10 (+V0) of CN1.

#### CN2 (right) input circuit

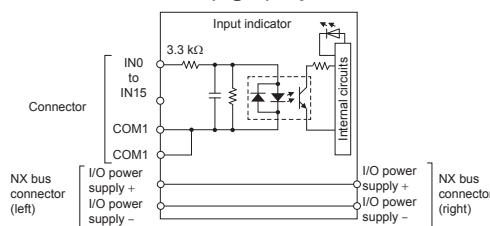

#### CN2 (right) input terminal

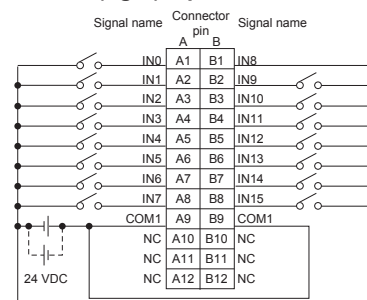

- The polarity of the input power supply of CN2 can be connected in either direction.
- Be sure to wire both pins A9 and B9 (COM1) of CN2, and set the same polarity for both pins.

Analog I/O unit

Current input unit

Item	Specifications									
Model	NX-AD2203	NX-AD3203	NX-AD4203	NX-AD2204	NX-AD3204	NX-AD4204	NX-AD2208	NX-AD3208	NX-AD4208	
Name	Current input unit									
Input range	4 to 20 mA									
Input method	Single-ended input					Differential input				
Capacity	2 points	4 points	8 points	2 points	4 points	8 points	2 points	4 points	8 points	
Input conversion range	-5% to 105% (full scale)									
Absolute maximum rating	±30 mA									
Input impedance	250 Ω min.	250 Ω min.	85 Ω min.	250 Ω min.	250 Ω min.	85 Ω min.	250 Ω min.	250 Ω min.	85 Ω min.	
Resolution	1/8,000 (full scale)						1/30,000 (full scale)			
Overall accuracy	25°C						±0.2% (full scale)			
	0 to 55°C						±0.4% (full scale)			
Conversion time	250 μs/point						10 μs/point			
	510 VAC between isolated circuits for 1 minute at a leakage current of 5 mA max.									
Insulation resistance	20 MΩ min. between isolated circuits (at 100 VDC)									
Isolation method	Between the input and the NX bus: Power = Transformer, Signal = Digital isolator (no isolation between inputs)									
Unit power consumption	0.90 W max.	0.90 W max.	1.05 W max.	0.90 W max.	0.90 W max.	1.05 W max.	0.90 W max.	0.95 W max.	1.10 W max.	
I/O power supply method	Supply from the NX bus					No supply				
I/O current consumption	No consumption									
Current capacity of I/O power supply terminal	0.1 A/terminal max.					Without I/O power supply terminals				
I/O refreshing method	Free-run refreshing						Switching synchronous I/O refreshing and free-run refreshing			
Terminal block type	Screwless push-in terminal 8 terminals (A + B)	Screwless push-in terminal 12 terminals (A + B)	Screwless push-in terminal 16 terminals (A + B)	Screwless push-in terminal 8 terminals (A + B)	Screwless push-in terminal 12 terminals (A + B)	Screwless push-in terminal 16 terminals (A + B)	Screwless push-in terminal 8 terminals (A + B)	Screwless push-in terminal 12 terminals (A + B)	Screwless push-in terminal 16 terminals (A + B)	
Dimensions (W x H x D)	12 x 100 x 71 mm									
Weight	70 g max.									
Input disconnection detection	Supported									

Circuit layout

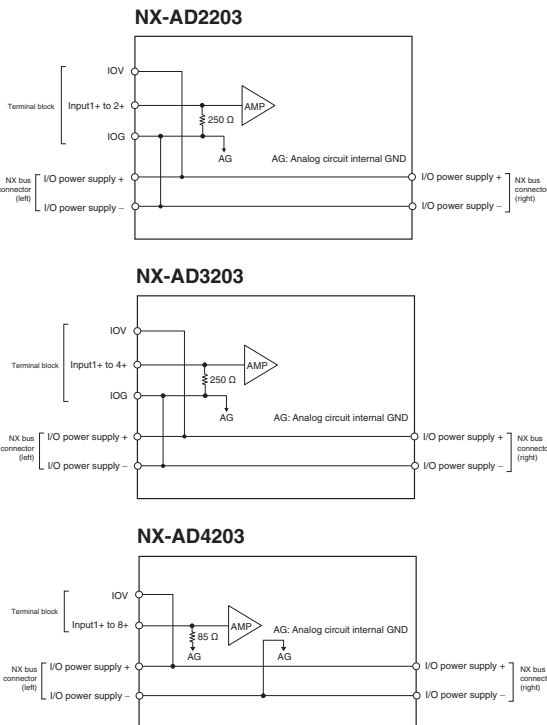

Terminal wiring

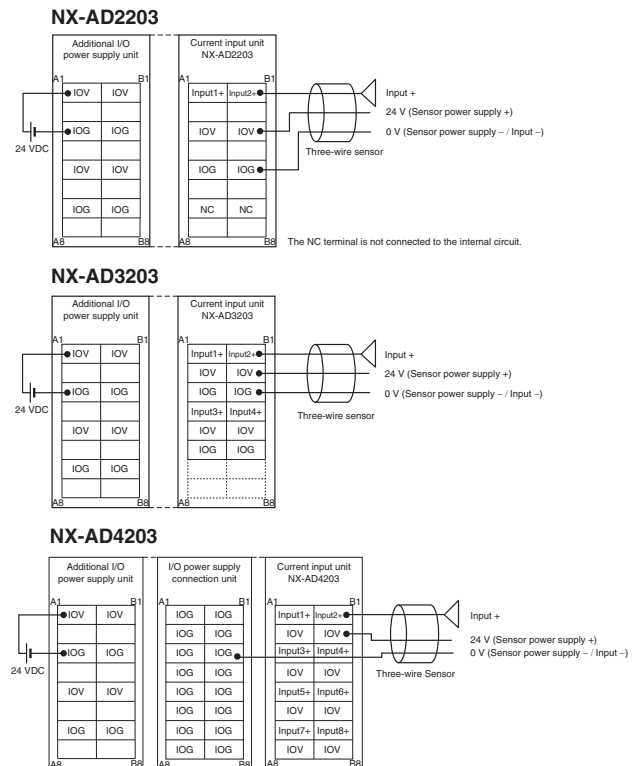

Circuit layout

NX-AD2204/NX-AD2208

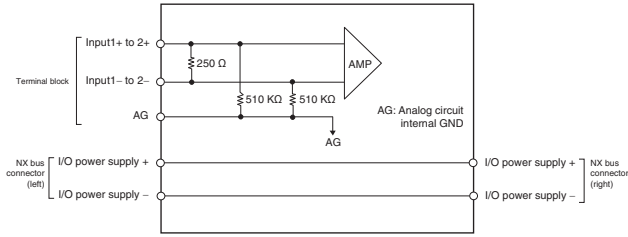

Terminal wiring

NX-AD2204/NX-AD2208

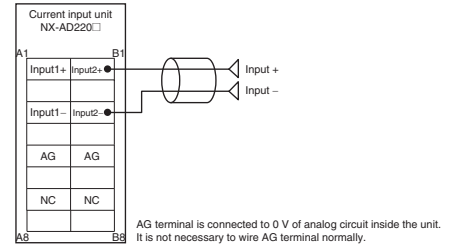

NX-AD3204/NX-AD3208

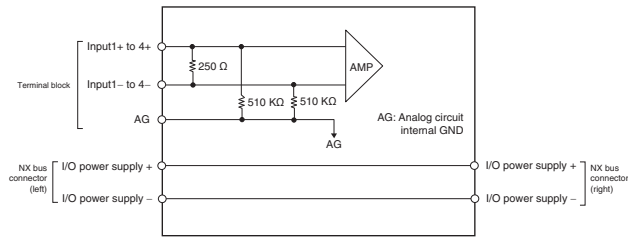

NX-AD3204/NX-AD3208

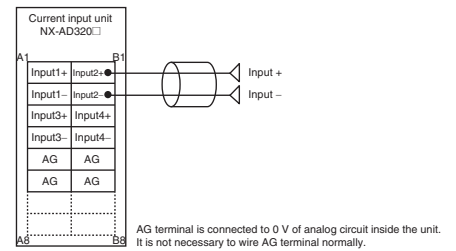

NX-AD4204/NX-AD4208

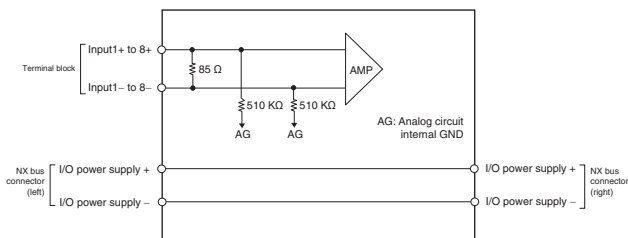

NX-AD4204/NX-AD4208

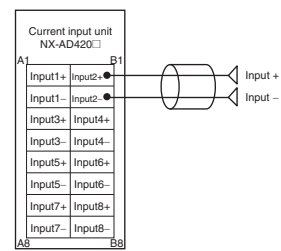

Voltage input unit

Item	Specifications									
Model	NX-AD2603	NX-AD3603	NX-AD4603	NX-AD2604	NX-AD3604	NX-AD4604	NX-AD2608	NX-AD3608	NX-AD4608	
Name	Voltage input unit									
Input range	-10 to 10 V									
Input method	Single-ended input					Differential input				
Capacity	2 points	4 points	8 points	2 points	4 points	8 points	2 points	4 points	8 points	
Input conversion range	-5% to 105% (full scale)									
Absolute maximum rating	±15 V									
Input impedance	1 MΩ min.									
Resolution	1/8,000 (full scale)					1/30,000 (full scale)				
Overall accuracy	25°C					±0.2% (full scale)				
	0 to 55°C					±0.4% (full scale)				
Conversion time	250 μs/point					10 μs/point				
Dielectric strength	510 VAC between isolated circuits for 1 minute at a leakage current of 5 mA max.									
Insulation resistance	20 MΩ min. between isolated circuits (at 100 VDC)									
Isolation method	Between the input and the NX bus: Power = Transformer, Signal = Digital isolator (no isolation between inputs)									
Unit power consumption	1.05 W max.	1.10 W max.	1.15 W max.	1.05 W max.	1.10 W max.	1.15 W max.	1.05 W max.	1.10 W max.	1.15 W max.	
I/O power supply method	Supply from the NX bus					No supply				
I/O current consumption	No consumption									
Current capacity of I/O power supply terminal	0.1 A/terminal max.					Without I/O power supply terminals				
I/O refreshing method	Free-run refreshing					Switching synchronous I/O refreshing and free-run refreshing				
Terminal block type	Screwless push-in terminal 8 terminals (A + B)	Screwless push-in terminal 12 terminals (A + B)	Screwless push-in terminal 16 terminals (A + B)	Screwless push-in terminal 8 terminals (A + B)	Screwless push-in terminal 12 terminals (A + B)	Screwless push-in terminal 16 terminals (A + B)	Screwless push-in terminal 8 terminals (A + B)	Screwless push-in terminal 12 terminals (A + B)	Screwless push-in terminal 16 terminals (A + B)	
Dimensions (W x H x D)	12 x 100 x 71 mm									
Weight	70 g max.									
Input disconnection detection	Not supported									

Circuit layout

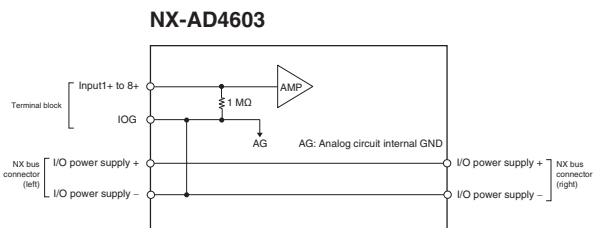
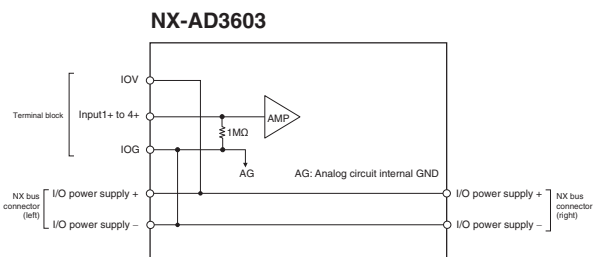
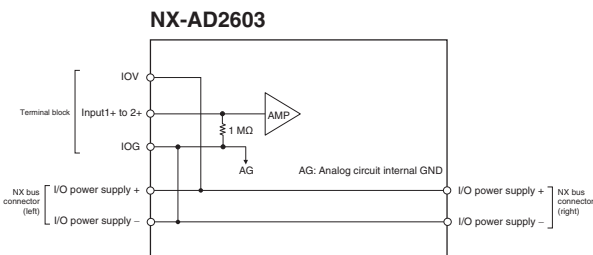

Terminal wiring

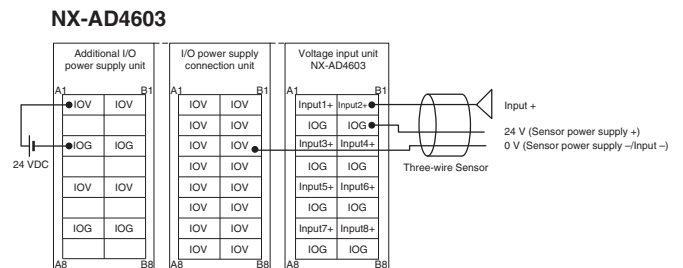
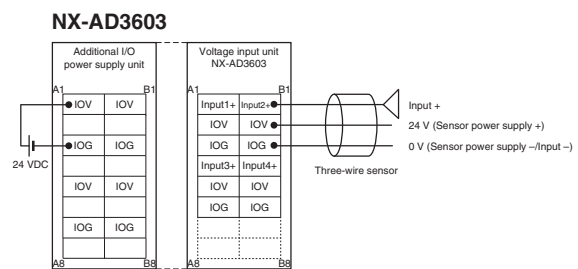
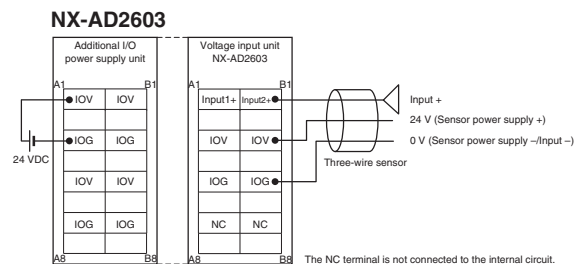

Circuit layout

NX-AD2604/NX-AD2608

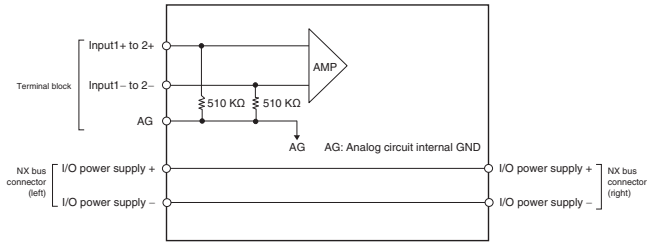

Terminal wiring

NX-AD2604/NX-AD2608

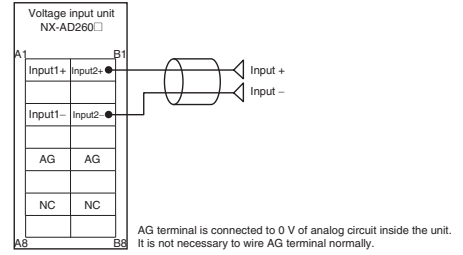

NX-AD3604/NX-AD3608

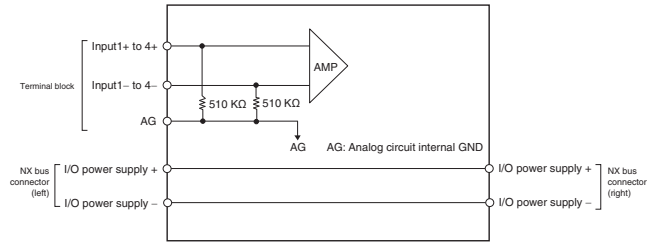

NX-AD3604/NX-AD3608

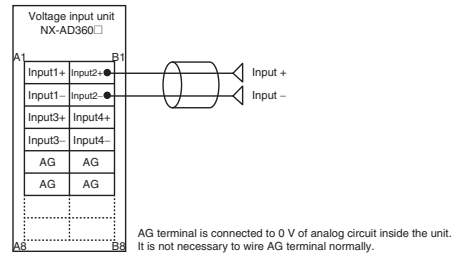

NX-AD4604/NX-AD4608

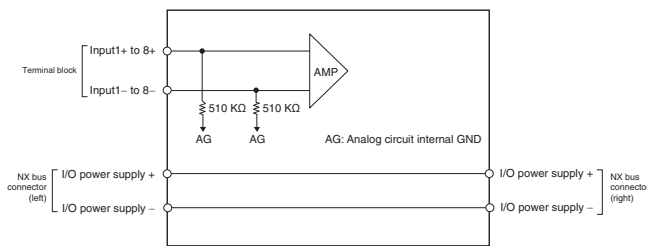

NX-AD4604/NX-AD4608

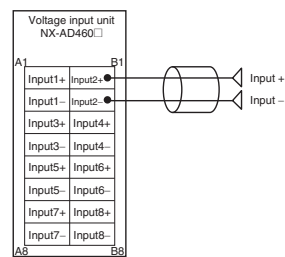

Current output unit

Item	Specifications			
Model	<b>NX-DA2203</b>	<b>NX-DA3203</b>	<b>NX-DA2205</b>	<b>NX-DA3205</b>
Name	Current output unit			
Output range	4 to 20 mA			
Capacity	2 points	4 points	2 points	4 points
Output conversion range	-5% to 105% (full scale)			
Allowable load resistance	600 Ω min.	350 Ω min.	600 Ω min.	350 Ω min.
Resolution	1/8,000 (full scale)		1/30,000 (full scale)	
Overall accuracy	25°C		±0.1% (full scale)	
	0 to 55°C		±0.3% (full scale)	
Conversion time	250 μs/point		10 μs/point	
Dielectric strength	510 VAC between isolated circuits for 1 minute at a leakage current of 5 mA max.			
Insulation resistance	20 MΩ min. between isolated circuits (at 100 VDC)			
Isolation method	Between the input and the NX bus: Power = Transformer, Signal = Digital isolator (no isolation between inputs)			
Unit power consumption	1.75 W max.	1.80 W max.	1.75 W max.	1.80 W max.
I/O power supply method	Supply from the NX bus			
I/O current consumption	No consumption			
Current capacity of I/O power supply terminal	0.1 A/terminal max.			
I/O refreshing method	Free-run refreshing		Switching synchronous I/O refreshing and free-run refreshing	
Terminal block type	Screwless push-in terminal 8 terminals (A + B)	Screwless push-in terminal 12 terminals (A + B)	Screwless push-in terminal 8 terminals (A + B)	Screwless push-in terminal 12 terminals (A + B)
Dimensions (W x H x D)	12 x 100 x 71 mm			
Weight	70 g max.			

Circuit layout

NX-DA2203/DA2205

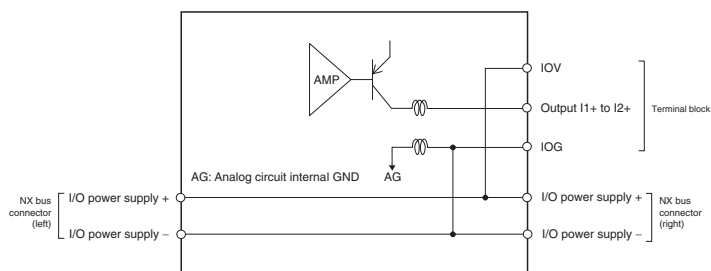

NX-DA3203/DA3205

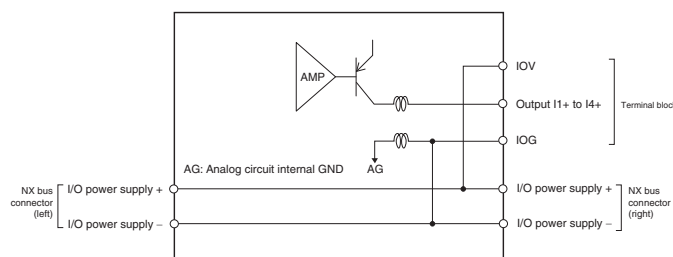

Terminal wiring

NX-DA2203/DA2205

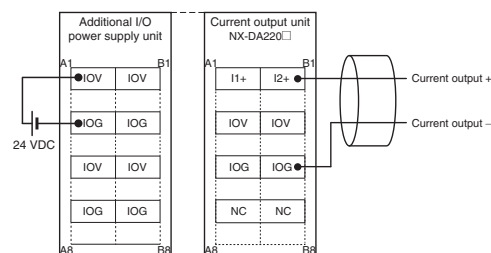

NX-DA3203/DA3205

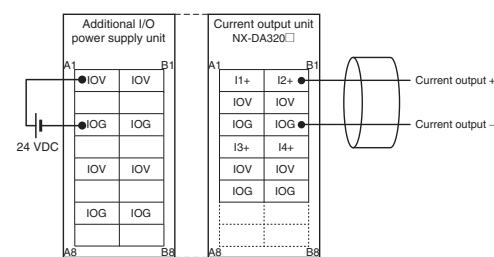

## Voltage output unit

Item	Specifications			
Model	NX-DA2603	NX-DA3603	NX-DA2605	NX-DA3605
Name	Voltage output unit			
Output range	-10 to 10 V			
Capacity	2 points	4 points	2 points	4 points
Output conversion range	-5% to 105% (full scale)			
Allowable load resistance	5 kΩ min.			
Output impedance	0.5 Ω max.			
Resolution	1/8,000 (full scale)		1/30,000 (full scale)	
Overall accuracy	25°C		±0.1% (full scale)	
	0 to 55°C		±0.3% (full scale)	
Conversion time	250 μs/point		10 μs/point	
Dielectric strength	510 VAC between isolated circuits for 1 minute at a leakage current of 5 mA max.			
Insulation resistance	20 MΩ min. between isolated circuits (at 100 VDC)			
Isolation method	Between the input and the NX bus: Power = Transformer, Signal = Digital isolator (no isolation between inputs)			
Unit power consumption	1.10 W max.	1.25 W max.	1.10 W max.	1.25 W max.
I/O power supply method	Supply from the NX bus			
I/O current consumption	No consumption			
Current capacity of I/O power supply terminal	0.1 A/terminal max.			
I/O refreshing method	Free-run refreshing		Switching synchronous I/O refreshing and free-run refreshing	
Terminal block type	Screwless push-in terminal		Screwless push-in terminal	
	8 terminals (A + B)		12 terminals (A + B)	
Dimensions (W x H x D)	12 x 100 x 71 mm			
Weight	70 g max.			

### Circuit layout

#### NX-DA2603/DA2605

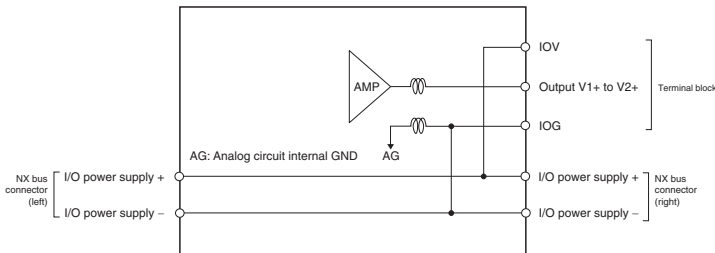

### Terminal wiring

#### NX-DA2603/DA2605

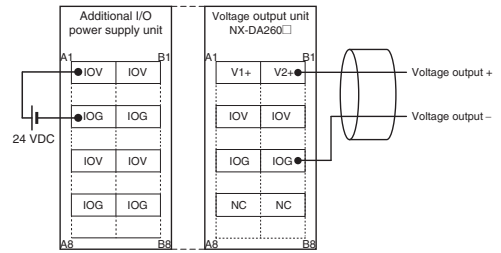

#### NX-DA3603/DA3605

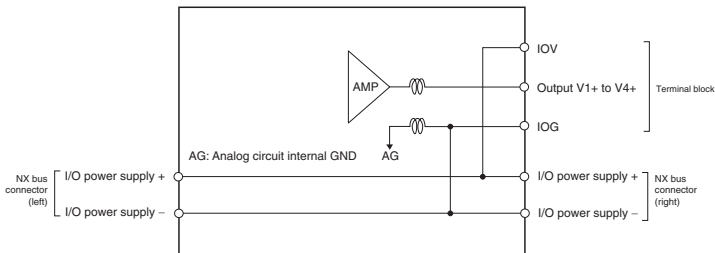

#### NX-DA3603/DA3605

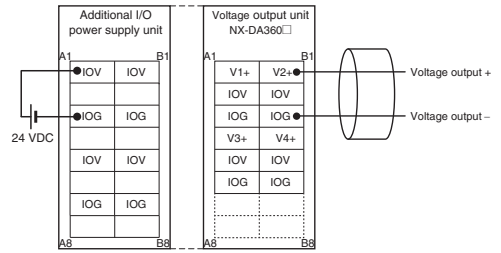

Temperature input unit

Thermocouple input unit

Item	Specifications					
Model	NX-TS2101	NX-TS3101	NX-TS2102	NX-TS3102	NX-TS2104	NX-TS3104
Name	Thermocouple type					
Capacity	2 points	4 points	2 points	4 points	2 points	4 points
Temperature sensor	K, J, T, E, L, U, N, R, S, B, WRe5-26, PLII					
Input conversion range	±20°C of the input range					
Input detection current	Approx. 0.1 µA					
Input impedance	20 KΩ min.					
Absolute maximum rating	±130 mV					
Resolution	0.1°C max. <sup>*1</sup>		0.01°C max.		0.001°C max.	
Warm-up period	30 minutes		45 minutes			
Reference accuracy and temperature coefficient	Conversion time		250 ms		10 ms	
	Temperature range		K, N (-200 to 1,300°C) J (-200 to 1,200°C) T (-200 to 400°C) E (-200 to 1,000°C) L (-200 to 900°C) U (-200 to 600°C) R, S (-50 to 1,700°C) B (0 to 1,800°C) WRe5-26 (0 to 2,300°C) PLII (0 to 1,300°C)		K, N (-200 to 1,300°C) K (-20 to 600°C, high resolution) J (-200 to 1,200°C) J (-20 to 600°C, high resolution) T (-200 to 400°C) E (-200 to 1,000°C) L (-200 to 900°C) U (-200 to 600°C) R, S (-50 to 1,700°C) WRe5-26 (0 to 2,300°C) PLII (0 to 1,300°C)	
	Accuracy <sup>*2</sup>		K/J/E/L/N/R/S/PLII (±0.1%) T (±0.2%) U (±0.15%) WRe5-26 (±0.05%)		T (±0.22%) R/S (±0.19%) N (±0.11%) U (±0.09%) K/J/E/L/WRe5-26/PLII (±0.05%)	
Dielectric strength	510 VAC between isolated circuits for 1 minute at a leakage current of 5 mA max.					
Insulation resistance	20 MΩ min. between isolated circuits (at 100 VDC)					
Isolation method	Between the input and the NX bus: Power = Transformer Signal = Photocoupler Between inputs: Power = Transformer, Signal = Photocoupler			Between the input and the NX bus: Power = Transformer, Signal = Digital isolator Between inputs: Power = Transformer Signal = Digital isolator		
Unit power consumption	0.90 W max.	1.30 W max.	0.80 W max.	1.10 W max.	0.80 W max.	1.10 W max.
I/O power supply method	No supply					
I/O current consumption	No consumption					
Current capacity of I/O power supply terminal	Without I/O power supply terminals					
I/O refreshing method	Free-run refreshing					
Terminal block type	Screwless push-in terminal 16 terminals (A + B)	Screwless push-in terminal 16 terminals x 2 [(A + B) & (C + D)]	Screwless push-in terminal 16 terminals (A + B)	Screwless push-in terminal 16 terminals x 2 [(A + B) & (C + D)]	Screwless push-in terminal 16 terminals (A + B)	Screwless push-in terminal 16 terminals x 2 [(A + B) & (C + D)]
Dimensions (W x H x D)	12 x 100 x 71 mm	24 x 100 x 71 mm	12 x 100 x 71 mm	24 x 100 x 71 mm	12 x 100 x 71 mm	24 x 100 x 71 mm
Weight	70 g max.	140 g max.	70 g max.	140 g max.	70 g max.	140 g max.

\*1. The resolution is 0.2°C max. when the input type is R, S or W.

\*2. Accuracy for temperature inputs as percentage of process value and typical value 25°C ambient temperature (refer to the user's manual for detailed information).

Terminal wiring

NX-TS2101/TS2102/TS2104

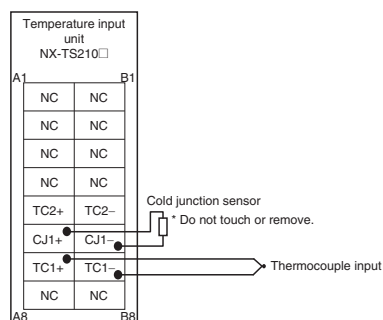

NX-TS3101/TS3102/TS3104

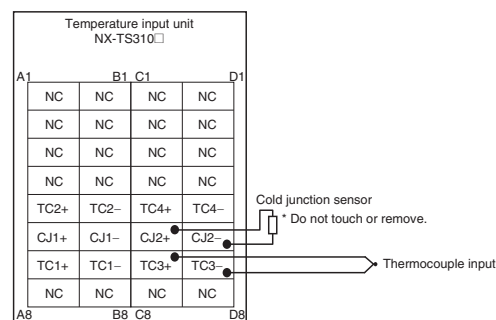

## Resistance thermometer input unit

Item	Specifications					
Model	NX-TS2201	NX-TS3201	NX-TS2202	NX-TS3202	NX-TS2204	NX-TS3204
Name	Resistance thermometer type					
Capacity	2 points	4 points	2 points	4 points	2 points	4 points
Temperature sensor	Pt100 (three-wire)/Pt1000 (three-wire)		Pt100 (three-wire)		Pt100 (three-wire)/Pt1000 (three-wire)	
Input conversion range	±20°C of the input range					
Input detection current	Approx. 0.25 mA					
Resolution	0.1°C max.		0.01°C max.		0.001°C max.	
Effect of conductor resistance	0.06°C/Ω max. (also 20 Ω max.)					
Warm-up period	10 minutes		30 minutes			
Reference accuracy and temperature coefficient	Conversion time		250 ms		60 ms	
	Temperature range		-200 to 850°C			
	Accuracy <sup>*1</sup>		±0.1%		±0.05%	
Dielectric strength	510 VAC between isolated circuits for 1 minute at a leakage current of 5 mA max.					
Insulation resistance	20 MΩ min. between isolated circuits (at 100 VDC)					
Isolation method	Between the input and the NX bus: Power = Transformer Signal = Photocoupler Between inputs: Power = Transformer Signal = Photocoupler		Between the input and the NX bus: Power = Transformer Signal = Digital isolator Between inputs: Power = Transformer Signal = Digital isolator			
Unit power consumption	0.90 W max.	1.30 W max.	0.75 W max.	1.05 W max.	0.75 W max.	1.05 W max.
I/O power supply method	No supply					
I/O current consumption	No consumption					
Current capacity of I/O power supply terminal	Without I/O power supply terminals					
I/O refreshing method	Free-run refreshing					
Terminal block type	Screwless push-in terminal 16 terminals (A + B)	Screwless push-in terminal 16 terminals x 2 [(A + B) & (C + D)]	Screwless push-in terminal 16 terminals (A + B)	Screwless push-in terminal 16 terminals x 2 [(A + B) & (C + D)]	Screwless push-in terminal 16 terminals (A + B)	Screwless push-in terminal 16 terminals x 2 [(A + B) & (C + D)]
Dimensions (W x H x D)	12 x 100 x 71 mm	24 x 100 x 71 mm	12 x 100 x 71 mm	24 x 100 x 71 mm	12 x 100 x 71 mm	24 x 100 x 71 mm
Weight	70 g max.	140 g max.	70 g max.	130 g max.	70 g max.	130 g max.

\*1. Accuracy for temperature inputs as percentage of process value and typical value 25°C ambient temperature (refer to the user's manual for detailed information).

## Terminal wiring

### NX-TS2201/TS2202/TS2204

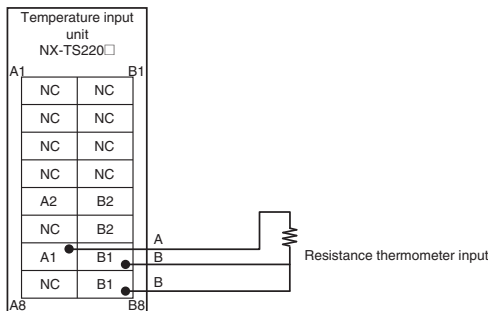

### NX-TS3201/TS3202/TS3204

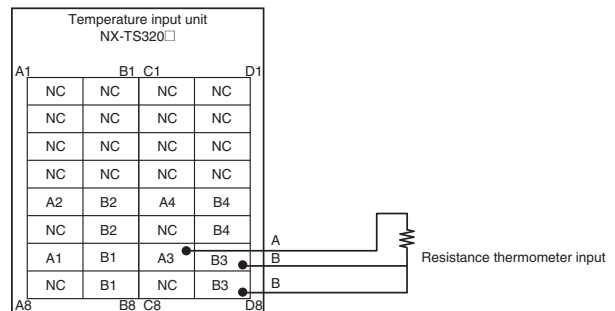

Heater burnout detection unit

Item	Specifications		
Model	NX-HB3101	NX-HB3201	
Name	Heater burnout detection unit		
Number of points	4 CT inputs and 4 control outputs		
CT inputs specifications	CT input current range	0 to 0.125 A	
	Input resistance	2.7 Ω approx.	
	Connectable CTs	E54-CT1 and E54-CT3	
	Max. heater current	50 A AC	
	Resolution	0.1 A	
	Overall accuracy (25°C)	± 5% (full scale) ± 1 digit	
	Influence of temperature (0 to 55°C)	± 2% (full scale) ± 1 digit	
	Conversion time	10 ms	
Control output specifications	Internal I/O common	NPN	PNP
	Control period	50 to 100,000 ms	
	Manipulated variable	0 to 100%	
	Resolution	1 ms	
	Rated voltage	12 to 24 VDC (10.2 to 28.8 VDC)	24 VDC (15 to 28.8 VDC)
	Max. load current	0.1 A/point, 0.4 A/unit	
	Max. inrush current	1.0 A/point max., 10 ms	
	Leakage current	0.1 mA max.	
	Residual voltage	1.5 V max.	
	Disconnection/short-circuit detection	None	
	Protective functions	None	Provided
Dielectric strength	510 VAC between isolated circuits for 1 minute at a leakage current of 5 mA max.		
Insulation resistance	20 MΩ min. between isolated circuits (at 100 VDC)		
Isolation method	Between control output and internal circuit: Photocoupler isolation No isolation between internal circuits and CT inputs		
Unit power consumption	0.75 W max.		
I/O power supply source	Supplied from the NX bus		
Current consumption from I/O power supply	20 mA max.		
Current capacity of I/O power supply terminal	IOV: 0.1 A max. per terminal		
I/O refreshing method	Free-run refreshing		
Terminal block type	Screwless push-in terminal 16 terminals (A + B)		
Dimensions (W x H x D)	12 x 100 x 71 mm		
Weight	70 g		

Circuit layout

NX-HB3101

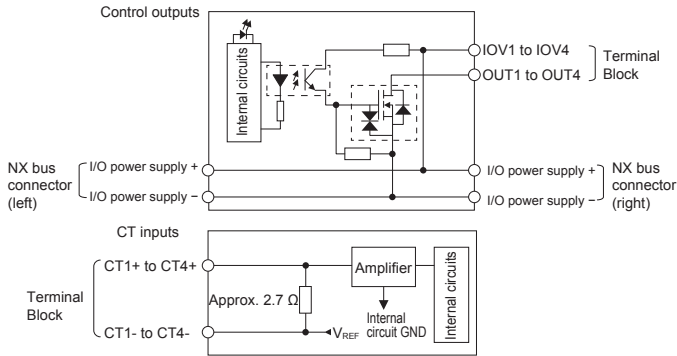

NX-HB3201

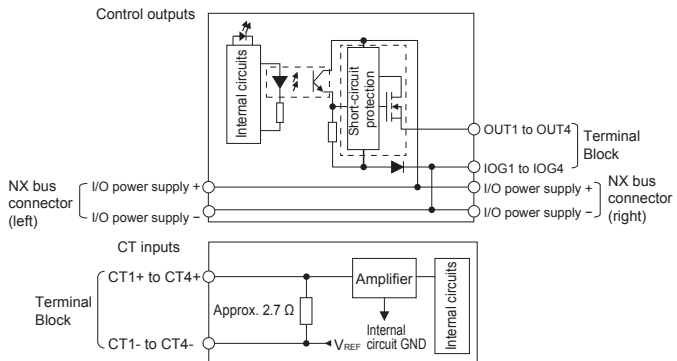

Terminal wiring

NX-HB3101

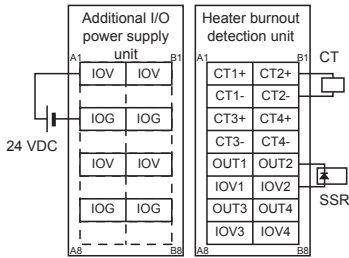

NX-HB3201

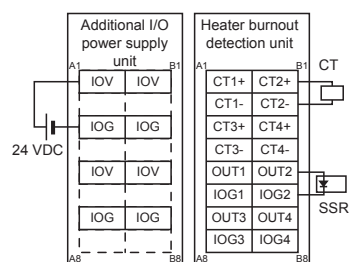

## Position interface unit

### Incremental encoder input unit

Item		Specifications					
Model		<b>NX-EC0112</b>	<b>NX-EC0122</b>	<b>NX-EC0212</b>	<b>NX-EC0222</b>	<b>NX-EC0132</b>	<b>NX-EC0142</b>
Name		Incremental encoder input unit					
Number of channels		1 channel			2 channels		1 channel
Input signals		Counter: Phases A, B and Z External inputs: 3			Counter: Phases A, B and Z External inputs: None		Counter: Phases A, B and Z External inputs: 3
Input form	Type	NPN type 500 kHz	PNP type 500 kHz	NPN type 500 kHz	PNP type 500 kHz	Line driver, 4 MHz	
	Specifications	Voltage				EIA standard RS-422-A line driver levels	
		Current				Impedance: 120 Ω ±5% Level input voltage: V <sub>IT+</sub> : 0.1 V min. V <sub>IT-</sub> : 0.1 V min. Hysteresis voltage: V <sub>hys</sub> (V <sub>IT+</sub> - V <sub>IT-</sub> ): 60 mV	
	5 V power supply for encoder		-				Output voltage: 5 VDC ±5% Output current: 500 mA max.
Maximum response frequency		Phases A and B: Single-phase 500 kHz (phase difference pulse input × 4: 125 kHz), Phase Z: 125 kHz				Phases A and B: Single-phase 4 MHz (phase differential pulse input × 4: 1 MHz), Phase Z: 1 MHz	
Counting units		Pulses					
Pulse input method		Phase difference pulse (multiplication × 2/4), pulse + direction inputs or up and down pulse inputs					
Counter range		-2,147,483,648 to 2,147,483,647 pulses					
Counter functions	Type	Ring counter or linear counter					
	Controls	Gate control, counter reset and counter preset					
	Latch function	Two external input latches and one internal latch					
	Measurements	Pulse rate measurement and pulse period measurement					
External input specifications	Input voltage	20.4 to 28.8 VDC (24 VDC +20%/−15%)			-		20.4 to 28.8 VDC (24 VDC +20%/−15%)
	Input current	4.6 mA (24 VDC)			-		3.5 mA (24 VDC)
	ON voltage/ON current	15 VDC min./3 mA min.			-		15 VDC min./3 mA min.
	OFF voltage/OFF current	4.0 VDC max./1 mA max.			-		5.0 VDC max./1 mA max.
	ON/OFF response time	1 μs max./2 μs max.			-		1 μs max./1 μs max.
	Internal I/O common	NPN		PNP		-	
Dielectric strength		510 VAC between isolated circuits for 1 minute at a leakage current of 5 mA max.					
Insulation resistance		20 MΩ min. between isolated circuits (at 100 VDC)					
Isolation method		Photocoupler isolation				Digital isolator	
Unit power consumption		0.85 W max.		0.95 W max.		0.85 W max.	0.95 W max.
I/O power supply source		Supplied from the NX bus. 20.4 to 28.8 VDC (24 VDC +20%/−15%)					
Current consumption from I/O power supply		None				30 mA	
Current capacity of I/O power supply terminal		0.3 A max. per terminal for encoder supply section and 0.1 A max. per terminal for other sections			0.3 A max. per terminal		0.1 A max. per terminal
I/O refreshing method		Free-run refreshing or synchronous I/O refreshing <sup>*1</sup>					
Terminal block type		Screwless push-in terminal 16 terminals (A + B)			Screwless push-in terminal 12 terminals (A + B)		Screwless push-in terminal 12 terminals x 2 [(A + B) x 2]
Dimensions (W x H x D)		12 x 100 x 71 mm				24 x 100 x 71 mm	
Weight		70 g				130 g	
Failure detection		None					
Protection		None					

\*1. The I/O refreshing method is automatically set according to the connected communication unit and CPU unit.

#### Circuit layout

##### NX-EC0112

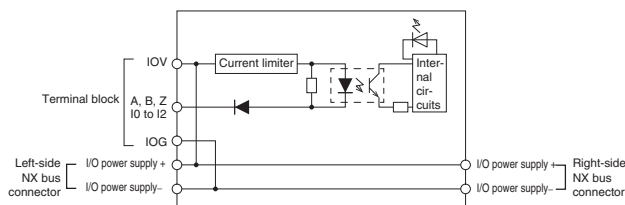

##### NX-EC0122

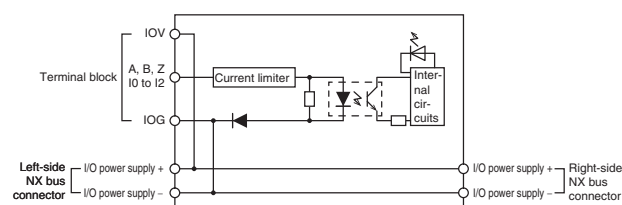

#### Terminal wiring

##### NX-EC0112

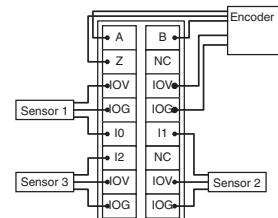

##### NX-EC0122

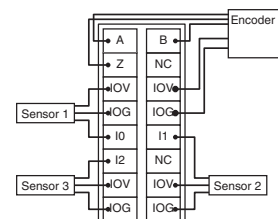

**Circuit layout**

**NX-EC0212**

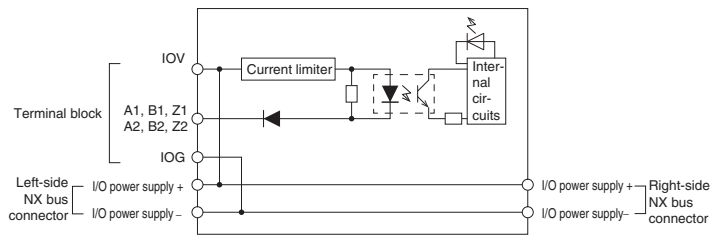

**Terminal wiring**

**NX-EC0212**

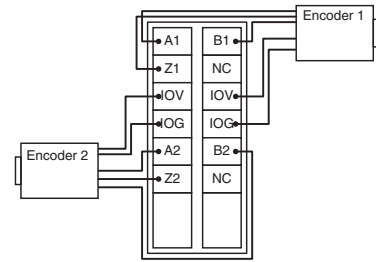

**NX-EC0222**

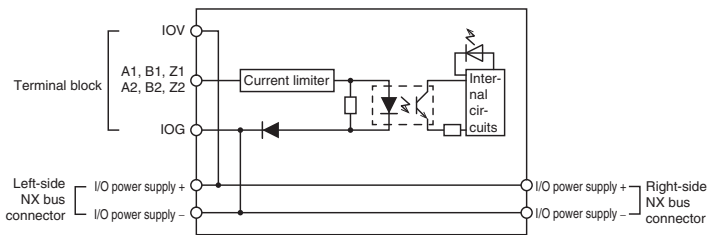

**NX-EC0222**

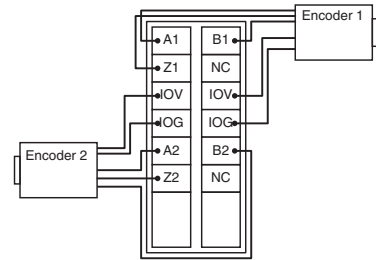

**NX-EC0132/EC0142**

**Encoder Input (NX-EC0132/EC0142)**

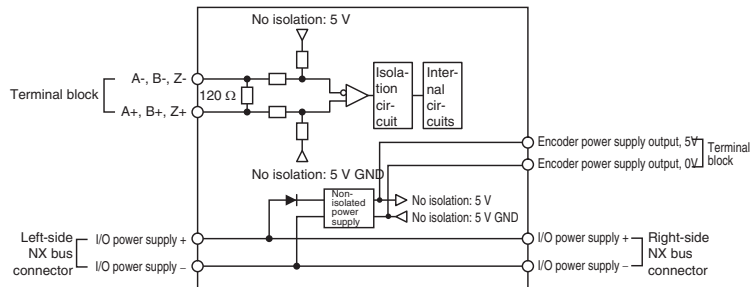

**NX-EC0132/EC0142**

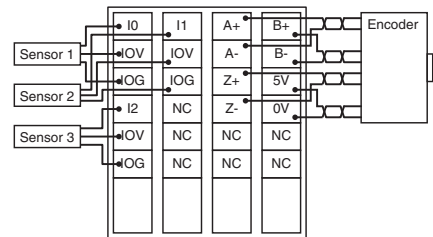

**External Inputs (NX-EC0132)**

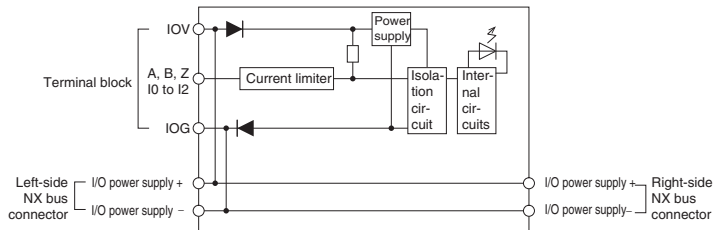

**External Inputs (NX-EC0142)**

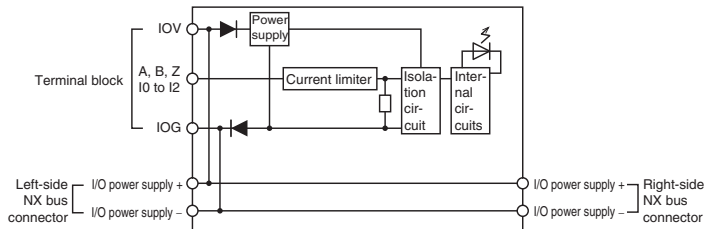

## SSI input unit

Item	Specifications	
Model	<b>NX-ECS112</b>	<b>NX-ECS212</b>
Name	SSI input unit	
Number of channels	1 channel	2 channels
Input signals	External inputs: 2 data input (D+, D-) External outputs: 2 clock output (C+, C-)	
I/O interface	Synchronous serial interface (SSI), 2 MHz	
Clock output	EIA standard RS-422-A line driver levels	
Data input	EIA standard RS-422-A line receiver levels	
Maximum data length	32 bits (the single-turn, multi-turn and status data length can be set)	
Coding method	No conversion, binary code or gray code	
Baud rate	100 kHz, 200 kHz, 300 kHz, 400 kHz, 500 kHz, 1.0 MHz, 1.5 MHz or 2.0 MHz	
Dielectric strength	510 VAC between isolated circuits for 1 minute at a leakage current of 5 mA max.	
Insulation resistance	20 MΩ min. between isolated circuits (at 100 VDC)	
Isolation method	Digital isolator	
Unit power consumption	0.85 W max.	0.90 W max.
I/O power supply source	Supplied from the NX bus. 20.4 to 28.8 VDC (24 VDC +20%/−15%)	
Current consumption from I/O power supply	20 mA	30 mA
Current capacity of I/O power supply terminal	0.3 A max. per terminal	
I/O refreshing method	Free-run refreshing or synchronous I/O refreshing <sup>1</sup>	
Terminal block type	Screwless push-in terminal 12 terminals (C + D)	Screwless push-in terminal 12 terminals (C + D)
Dimensions (W x H x D)	12 x 100 x 71 mm	
Weight	65 g	
Maximum transmission distance <sup>2</sup>	100 kHz (400 m), 200 kHz (190 m), 300 kHz (120 m), 400 kHz (80 m), 500 kHz (60 m), 1.0 MHz (25 m), 1.5 MHz (10 m) or 2.0 MHz (5 m)	
Failure detection	None	
Protection	None	

\*1. The I/O refreshing method is automatically set according to the connected communication unit and CPU unit.

\*2. The maximum transmission distance for an SSI input unit depends on the baud rate due to the delay that can result from the responsiveness of the connected encoder and cable impedance. The maximum transmission distance is only a guideline. Review the specifications for the cables and encoders in the system and evaluate the operation of the equipment before use.

### Circuit layout

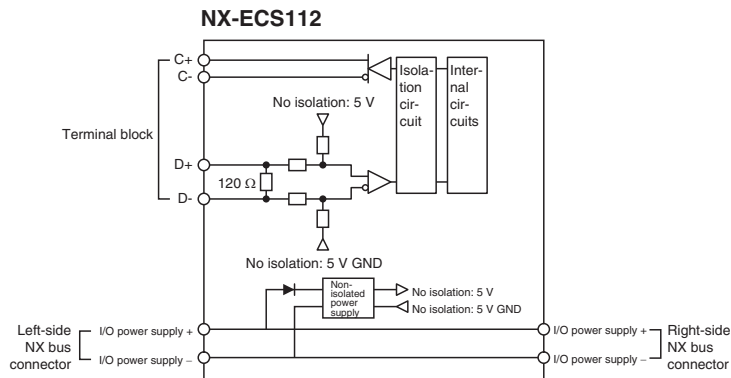

### Terminal wiring

#### NX-ECS112

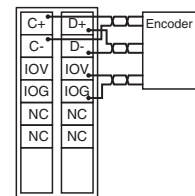

### NX-ECS212

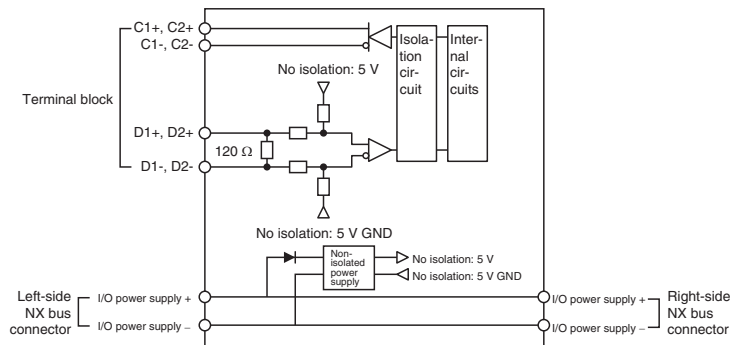

#### NX-ECS212

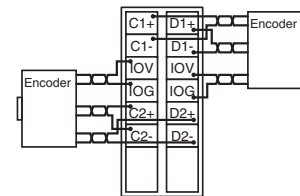

Pulse output unit

Item	Specifications							
Model	NX-PG0112	NX-PG0122	NX-PG0232-5	NX-PG0242-5	NX-PG0332-5	NX-PG0342-5		
Name	Pulse output unit							
Number of axes	1 axis		2 axis		4 axis			
I/O signals	External inputs: 2 general-purpose inputs / External outputs: 3 (forward direction pulse, reverse direction pulse and a general-purpose outputs)		Inputs: 5 per axis. External inputs <sup>1</sup> Outputs: 5 per axis (forward direction pulse, reverse direction pulse and 3 external outputs per channel <sup>2</sup> )					
Control method	Open-loop control through pulse train output		Open-loop control through pulse string output					
Controlled drive	Servo drive with a pulse train input or a stepper motor drive		Servo drive with a pulse string input or a stepper motor drive					
Pulse output form	Open collector output		Line driver output					
Control unit	Pulses							
Maximum pulse output speed	500 kpps		4 Mpps					
Pulse output method	Forward/reverse direction pulse outputs or pulse + direction outputs		Forward/reverse direction pulse outputs, pulse + direction outputs or phase differential pulse output multiplication x1/2/4					
Position control range	-2,147,483,648 to 2,147,483,647 pulses							
Velocity control range	1 to 500,000 pps		1 to 4,000,000 pps					
Positioning <sup>3</sup>	Single-axis position control							
	Single-axis velocity control							
	Single-axis synchronized control							
	Single-axis manual operation							
	Auxiliary function for single-axis control							
External input specifications	Input voltage		20.4 to 28.8 VDC (24 VDC +20%/-15%)					
	Input current		4.6 mA (24 VDC)					
	ON voltage/ON current		15 VDC min./3 mA min.					
	OFF voltage/OFF current		4.0 VDC max./1 mA max.					
	ON/OFF response time		1 μs max./2 μs max.		External inputs 0 and 1: 1 μs max./2 μs max. External inputs 2 to 4: 20 μs max./400 μs max.			
	Internal I/O common processing		NPN	PNP	NPN	PNP	NPN	PNP
Line receiver inputs specifications	Input voltage		-					
	High/Low level input voltage		EIA standard RS-422-A line driver levels					
	Input impedance		V <sub>IT+</sub> : 0.1 V min./V <sub>IT-</sub> : -0.1 V max.					
	Hysteresis voltage		120 Ω ±5% V <sub>hys</sub> (V <sub>IT+</sub> -V <sub>IT-</sub> ): 60 mV					
External output specifications	Rated voltage		24 VDC (15 to 28.8 VDC)					
	Maximum load current		30 mA					
	ON/OFF response time		5 μs max./5 μs max.	External output 0: 5 μs max./5 μs max. External output 1 and 2: 0.5 ms max./1 ms max.	External output 0: 5 μs max./200 μs max. External output 1 and 2: 0.5 ms max./1 ms max.	External output 0: 5 μs max./5 μs max. External output 1 and 2: 0.5 ms max./1 ms max.	External output 0: 5 μs max./200 μs max. External output 1 and 2: 0.5 ms max./1 ms max.	
	Internal I/O common processing		NPN	PNP	NPN	PNP	NPN	PNP
	Residual voltage		1.0 V max.					
	Leakage current		0.1 mA					
Line driver output specifications	Output voltage		-					
	Maximum load current		RS-422-A line driver level (equivalent to AM26C31) 20 mA					
	Maximum output frequency		4 Mpps					
Dielectric strength	510 VAC between isolated circuits for 1 minute at a leakage current of 5 mA max.							
Insulation resistance	20 MΩ min. between isolated circuits (at 100 VDC)							
Isolation method	External inputs: Photocoupler isolation External outputs: Digital isolator							
Unit power consumption	0.8 W max.	0.9 W max.	1.20 W max.		1.30 W max.			
I/O power supply source	Supplied from the NX bus. 20.4 to 28.8 VDC (24 VDC +20%/-15%)		Supplied from external source. 20.4 to 28.8 VDC (24 VDC +20%/-15%)					
Current consumption from I/O power supply	20 mA		50 mA		50 mA/CN max.			
Current capacity of I/O power supply terminal	0.1 A max. per terminal		Without I/O power supply terminal					
Cable length	3 m max.		Line driver outputs: 10 m max. Other I/O: 3 m max.					
I/O refreshing method	Synchronous I/O refreshing <sup>4</sup>							
Terminal block type	Screwless push-in terminal 16 terminals (A + B)		MIL connector 34 terminals		2 MIL connectors 34 terminals			
Dimensions (W x H x D)	12 x 100 x 71 mm		30 x 100 x 71 mm					
Weight	70 g		110 g		150 g			
Failure detection	None							
Protection	None							

\*1. You can use the external input 0 as a latch input.

\*2. You can use the external output 0 as an error counter reset output.

\*3. These functions are supported when you also use the MC function module in the NJ-series CPU unit. Refer to the NJ-series CPU unit motion control user's manual (Cat.No. W507) for details. A pulse output unit only outputs pulses during the control period based on commands received at a fixed period. Target position calculations (distribution calculations) for acceleration/deceleration control or for each control period must be performed on the controller that is connected as the host.

\*4. The I/O refreshing method is automatically set according to the connected communication unit and CPU unit.

Circuit layout

NX-PG0112

Pulse Output and External Output

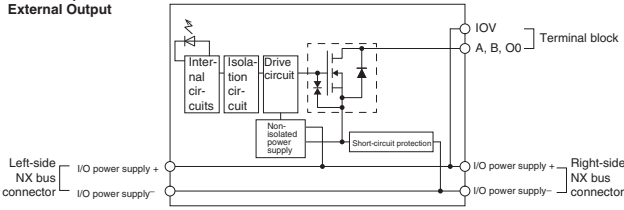

External Inputs

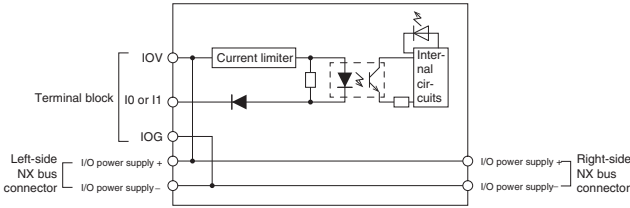

Terminal wiring

NX-PG0112

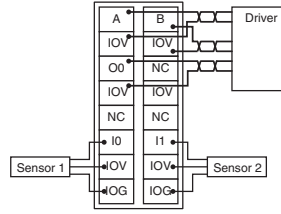

NX-PG0122

Pulse Output and External Output

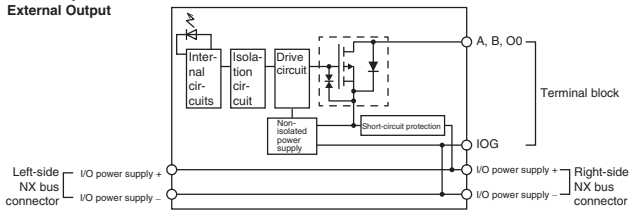

External Inputs

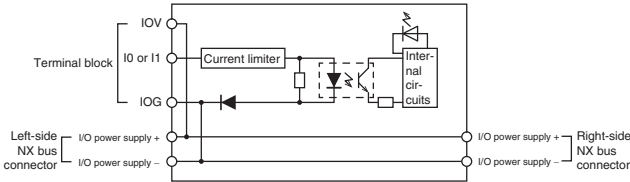

NX-PG0122

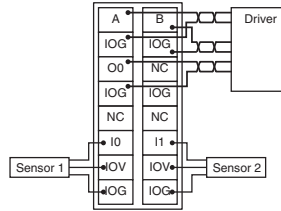

NX-PG0232-5/PG0332-5

Pulse Output

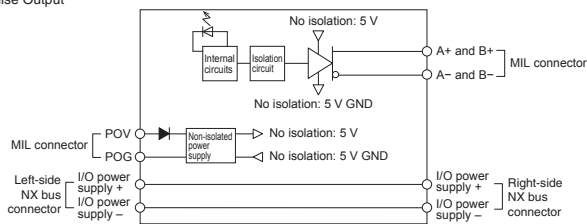

External Output

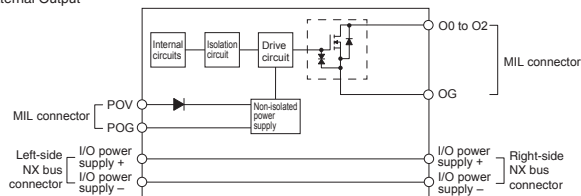

NX-PG0232-5/PG0332-5

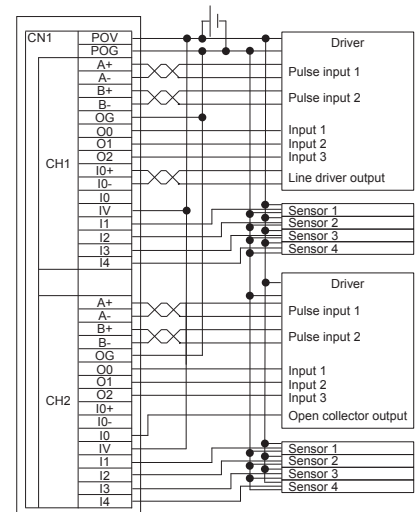

Circuit layout

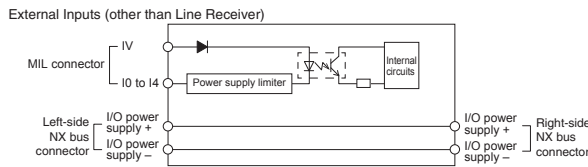
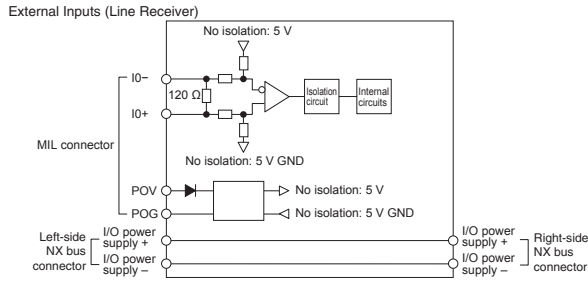

NX-PG0242-5/PG0342-5

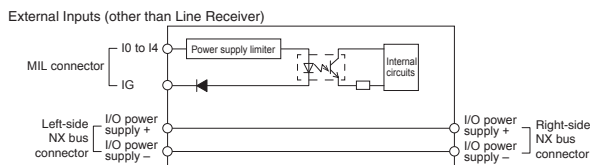
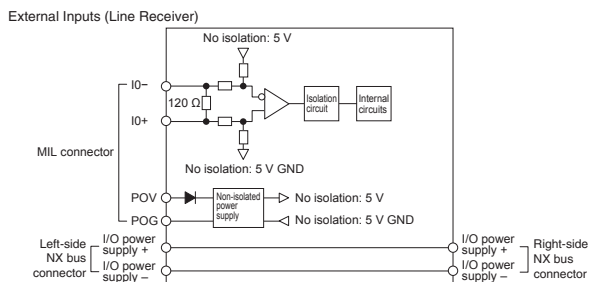
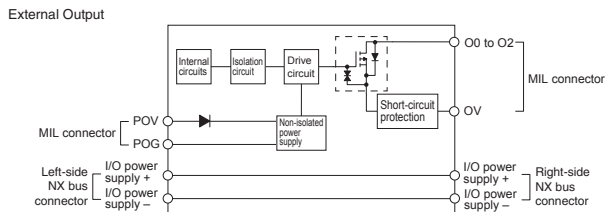
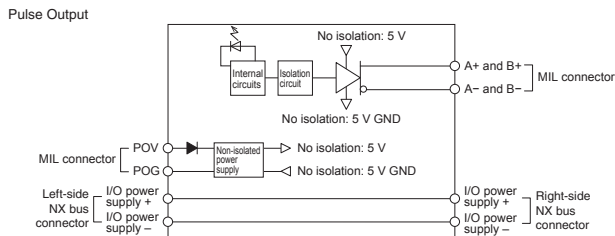

Terminal wiring

NX-PG0242-5/PG0342-5

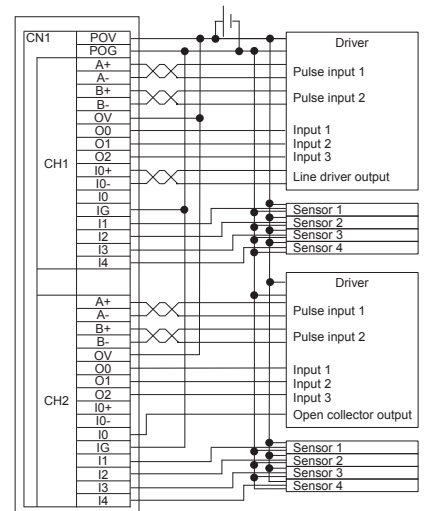

## Load cell input unit

Item	Specifications	
Model	NX-RS1201	
Name	Load cell input unit	
Number of inputs	1 input	
Input range	-5.0 to 5.0 mV/V	
Input conversion range	-5.5 to 5.5 mV/V	
Load cell excitation voltage	5 VDC $\pm$ 10%, output current: 60 mA max.	
Zero point adjustment range	-5.0 to 5.0 mV/V	
Gain point adjustment range	-5.0 to 5.0 mV/V	
Accuracy <sup>*1</sup>	Nonlinearity	$\pm$ 0.01% (full scale) <sup>*2</sup>
	Zero drift	$\pm$ 0.1 $\mu$ V/ $^{\circ}$ C RTI
	Gain drift	$\pm$ 10 ppm/ $^{\circ}$ C
A/D converter resolution	24 bits	
Conversion cycle	125 $\mu$ s	
Warm-up period	30 minutes	
Dielectric strength	510 VAC between isolated circuits for 1 minute at a leakage current of 5 mA max.	
Insulation resistance	20 M $\Omega$ min. between isolated circuits (at 100 VDC)	
Isolation method	Between the input and the NX bus: Power = Transformer, Signal = Digital isolator	
Unit power consumption	1.70 W max.	
I/O power supply source	No supply	
Current consumption from I/O power supply	No consumption	
Current capacity of I/O power supply terminal	Without I/O power supply terminals	
I/O refreshing method	Free-run refreshing or synchronous I/O refreshing <sup>*3</sup>	
Terminal block type	Screwless push-in terminal 16 terminals (A + B with FG)	
Dimensions (W x H x D)	12 x 100 x 71 mm	
Weight	70 g max.	

\*1. Accuracy when the load cell and the load cell input unit are connected with the 6-wire connection.

\*2. The value for when the load cell unit is used in the following conditions: Full scale: 0.0 to 5.0 mV/V or -5.0 to 0.0 mV/V. Ambient temperature: 25 $^{\circ}$ C. Setting of digital filtering: Default.

\*3. The I/O refreshing method is automatically set according to the connected communication unit and CPU unit.

### Circuit layout

#### NX-RS1201

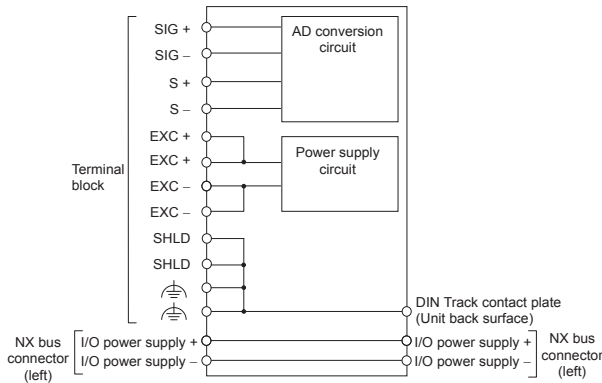

### Terminal wiring

#### NX-RS1201

Diagram of the 6-wire connection between the Unit and a load cell.

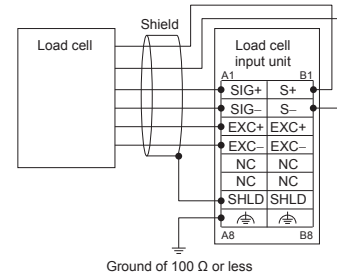

Ground of 100  $\Omega$  or less

Diagram of the 4-wire connection between the Unit and a load cell.

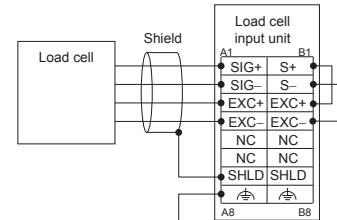

Ground of 100  $\Omega$  or less

Communication interface unit

Item	Specifications			
	NX-CIF101	NX-CIF210	NX-CIF105	
<b>Model</b>	NX-CIF101	NX-CIF210	NX-CIF105	
<b>Name</b>	Communication interface unit			
<b>Communication ports</b>	RS-232C		RS-422A/485	
<b>Number of ports</b>	1	2	1	
<b>Communication specifications</b>	<b>Communication method</b>	Full duplex		
	<b>Signal lines<sup>*1</sup></b>	-		
	<b>Baud rate [bps]<sup>*1</sup></b>	1200, 2400, 4800, 9600, 19200, 38400, 57600, 115200 or 230400		
	<b>Data length [bits]<sup>*1</sup></b>	7 or 8		
	<b>Parity<sup>*1</sup></b>	Even, odd or none		
	<b>Start bits [bits]</b>	Always 1		
	<b>Stop bits [bits]<sup>*1</sup></b>	1 or 2		
	<b>Flow control<sup>*1</sup></b>	None, RS/CS flow control or Xon/Xoff control	None or Xon/Xoff control	
	<b>Flow control target<sup>*1</sup></b>	Send/receive, send only or receive only		
	<b>Initial RS signal value<sup>*1,2</sup></b>	ON or OFF		
	<b>Number of characters to determine the end<sup>*1,3</sup></b>	0 to 10,000 (in increments of 0.1 character) 0: The end is not detected		
	<b>Max. communication distance</b>	15 m <sup>*4</sup>	1200 m <sup>*5</sup>	
	<b>Connection configuration</b>	1:1	1:N (max. value of N is 32) You can change between two-wire and four-wire connections	
<b>PDO data size [bytes]<sup>*1</sup></b>	Inputs or outputs: 4, 8, 12, 16, 20, 24, 28, 32, 36, 40, 44, 48, 52, 56, 60, 64, 68, 72, 76 or 80			
<b>Transmission buffering enable/disable setting<sup>*1</sup></b>	Enabled or disabled			
<b>Functions to back up data</b>	Provided <sup>*6</sup>			
<b>Terminating resistance setting</b>	-	Possible		
<b>Isolation method</b>	No-isolation	Power supply: Transformer and photocoupler Signals: Digital isolators		
<b>Unit power consumption</b>	0.9 W max.		1.45 W max.	
<b>I/O refreshing method</b>	Free-run refreshing			
<b>Terminal block type</b>	Screwless push-in terminal 16 terminals (A + B with FG)	D-Sub 9pin connector	Screwless push-in terminal 16 terminals (A + B with FG)	
<b>Dimensions (W x H x D)</b>	12 x 100 x 71 mm	30 x 100 x 71 mm	12 x 100 x 71 mm	
<b>Weight</b>	66 g max.	91 g max.	69 g max.	

\*1. Setting is possible in the unit operation settings of the Sysmac Studio software.

\*2. This is the value of the RS signal when the port enters the operational state or immediately after the port is restarted. The initial value is disabled when RS/CS flow control is set. It is also disabled for the NX-CIF105.

\*3. This setting is provided for communication protocols that assume the end of the data if data is not received for a specific period of time. For example, if the number of characters to determine the end is set to 35, the end of the data will be assumed if data is not received for the time required to receive 3.5 characters.

\*4. If the baud rate is set to higher than 19,200 bps, refer to the manual for the remote communications device.

\*5. The maximum total cable length for multidrop connections is 1200 m.

\*6. The settings that are backed up are saved in memory in the communication coupler unit, not in the communication interface unit.

## Power unit

### NX bus power supply unit

Item	Specifications
Model	<b>NX-PD1000</b>
Name	NX bus power supply unit
Power supply voltage	24 VDC (20.4 to 28.8 VDC)
NX unit power supply capacity	10 W max. (refer to installation orientation and restrictions for details)
NX unit power supply efficiency	70%
Unwired terminal current capacity	4 A max. (including the current of through wiring)
Dielectric strength	510 VAC between isolated circuits for 1 minute at a leakage current of 5 mA max.
Insulation resistance	20 MΩ min. between isolated circuits (at 100 VDC)
Isolation method	No-isolation
Unit power consumption	0.45 W max.
I/O current consumption	No consumption
Terminal block type	Screwless push-in terminal 8 terminals (A + B with FG)
Dimensions (W x H x D)	12 x 100 x 71 mm
Weight	65 g max.

#### Circuit layout

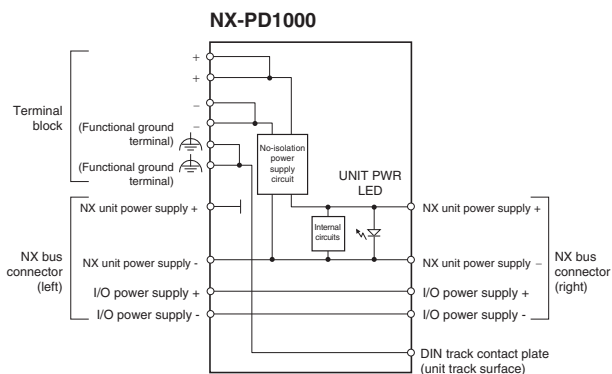

#### Terminal wiring

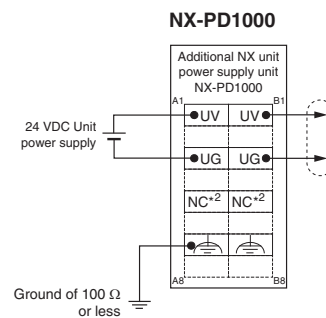

### I/O power feed unit

Item	Specifications
Model	<b>NX-PF0630</b>   <b>NX-PF0730</b>
Name	Additional I/O power supply unit
Power supply voltage	5 to 24 VDC (4.5 to 28.8 VDC) <sup>1</sup>
I/O power supply maximum current	4 A   10 A
Dielectric strength	510 VAC between isolated circuits for 1 minute at a leakage current of 5 mA max.
Insulation resistance	20 MΩ min. between isolated circuits (at 100 VDC)
Isolation method	No-isolation
Unit power consumption	0.45 W max.
I/O current consumption	10 mA max.
Current capacity of I/O power supply terminal	4 A max.   10 A max.
Terminal block type	Screwless push-in terminal 8 terminals (A + B)
Dimensions (W x H x D)	12 x 100 x 71 mm
Weight	65 g max.

\*1. Use an output voltage that is appropriate for the I/O circuits of the NX units and the connected external devices.

#### Circuit layout

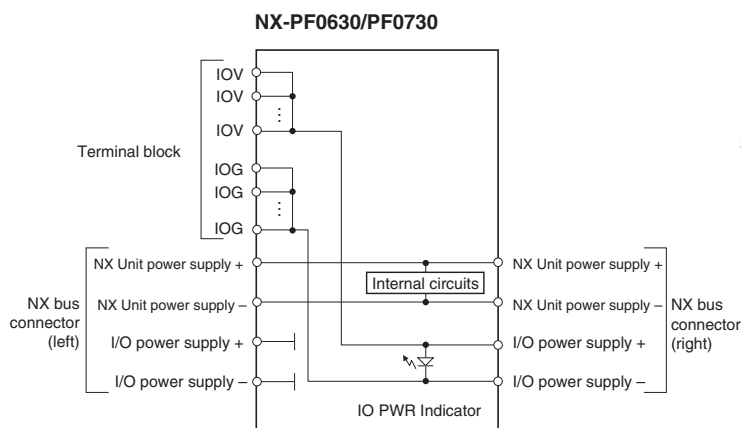

#### Terminal wiring

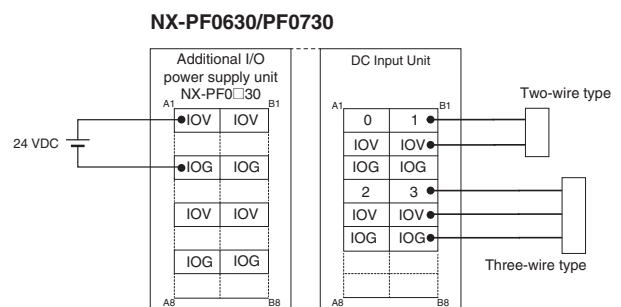

I/O power supply connection unit

Item	Specifications		
Model	<b>NX-PC0010</b>	<b>NX-PC0020</b>	<b>NX-PC0030</b>
Name	I/O power supply connection unit		
Dielectric strength	510 VAC between isolated circuits for 1 minute at a leakage current of 5 mA max.		
Insulation resistance	20 MΩ min. between isolated circuits (at 100 VDC)		
Isolation method	No-isolation		
Unit power consumption	0.45 W max.		
I/O current consumption	No consumption		
Current capacity of I/O power supply terminal	4 A/terminal max.		
Terminal block type	Screwless push-in terminal 16 terminals (A + B)		
Number of I/O power supply terminals	IOG: 16 terminals	IOV: 16 terminals	IOG: 8 terminals IOV: 8 terminals
Dimensions (W x H x D)	12 x 100 x 71 mm		
Weight	65 g max.		

Circuit layout

NX-PC0010

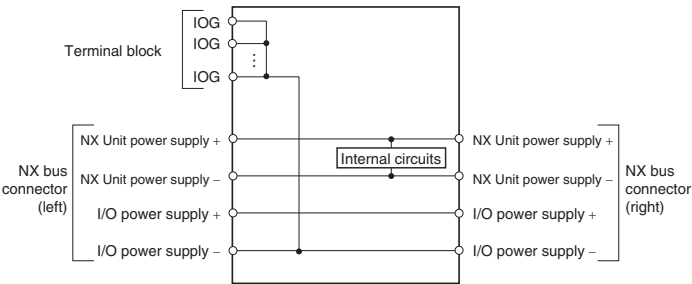

Terminal wiring

NX-PC0010

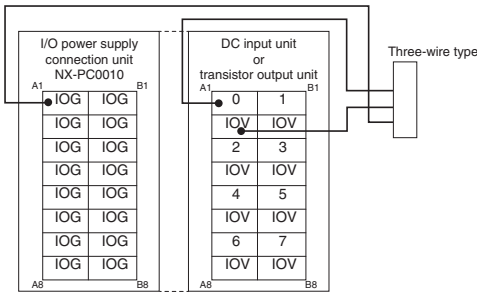

NX-PC0020

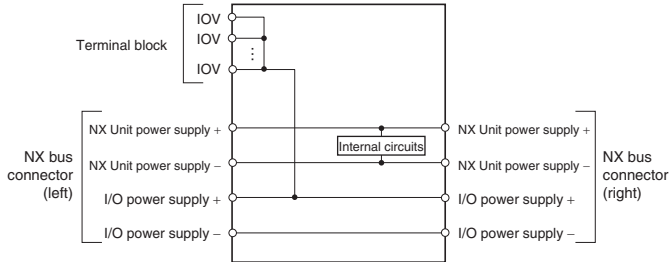

NX-PC0020

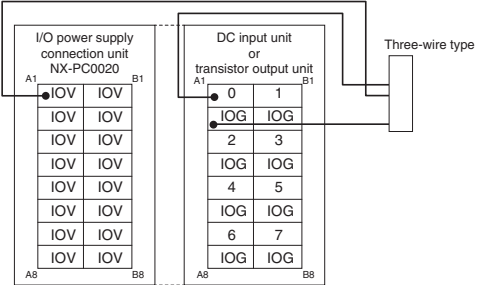

NX-PC0030

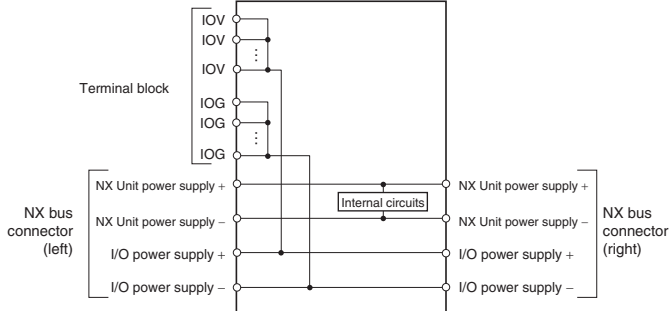

NX-PC0030

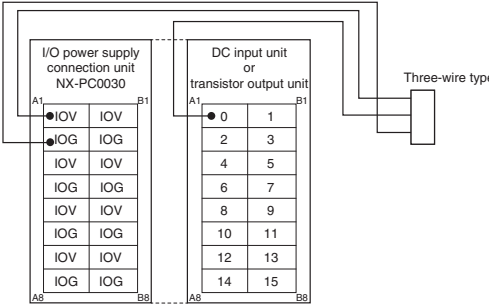

## System unit

### Shield connection unit (grounding terminal)

Item	Specifications
Model	NX-TBX01
Name	Shield connection unit
Dielectric strength	510 VAC between isolated circuits for 1 minute at a leakage current of 5 mA max.
Insulation resistance	20 M $\Omega$ min. between isolated circuits (at 100 VDC)
Isolation method	Isolation between the SHLD functional ground terminal and internal circuit: no-isolation
Unit power consumption	0.45 W max.
I/O current consumption	No consumption
Terminal block type	Screwless push-in terminal 16 terminals (A + B with FG)
Number of shield terminals	14 terminals (the following two terminals are Functional Ground terminals)
Dimensions (W x H x D)	12 x 100 x 71 mm
Weight	65 g max.

### Circuit layout

#### NX-TBX01

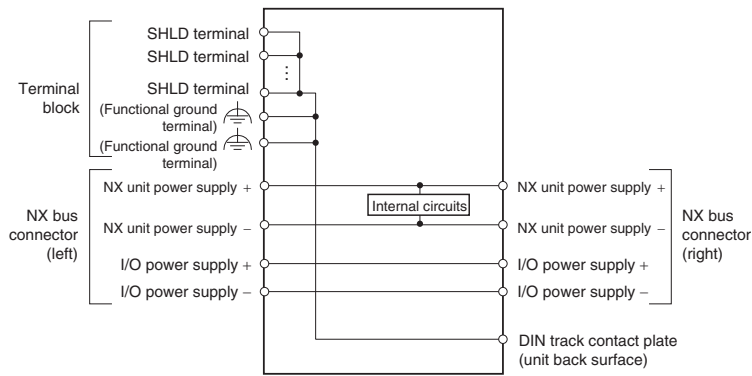

### Terminal wiring

#### NX-TBX01

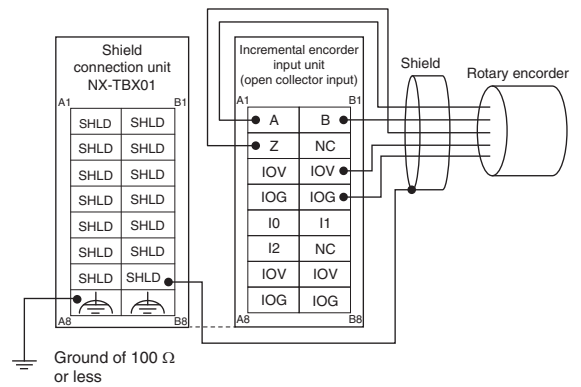

**Dimensions**

**Communication coupler unit (EtherCAT / EtherNet/IP)**  
**NX-ECC20@/EIC202**

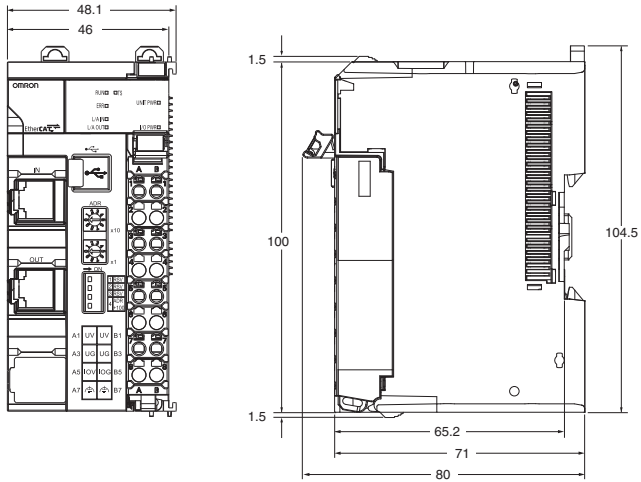

**End cover unit**  
**NX-END01**

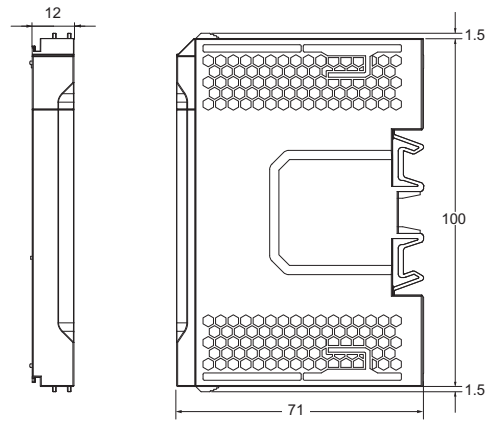

**I/O unit with screwless push-in terminal**

**12 mm width**

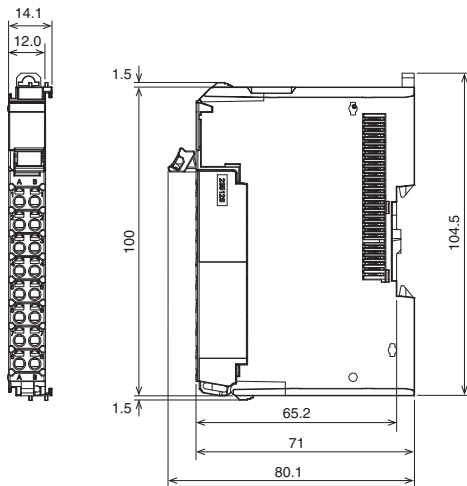

**24 mm width**

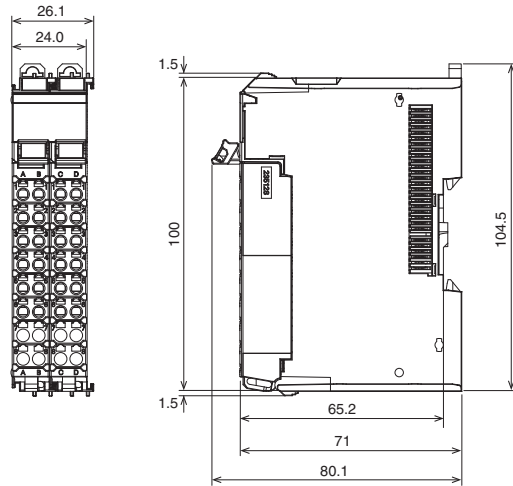

**I/O unit with MIL connector**

**1 connector with 20 terminals**

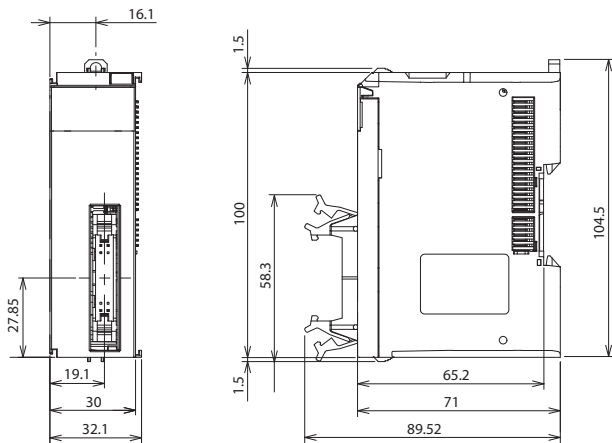

**1 connector with 34 terminals**

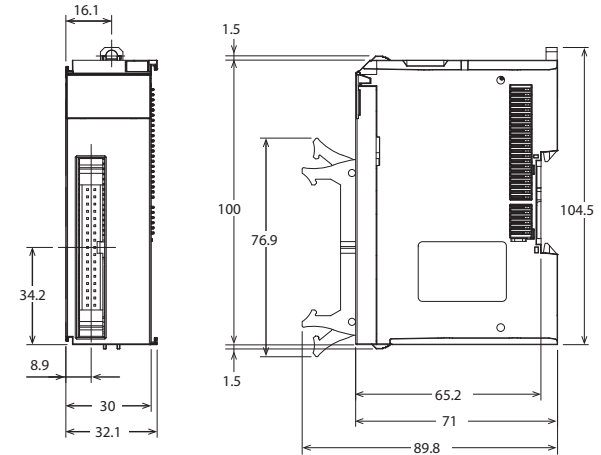

1 connector with 40 terminals

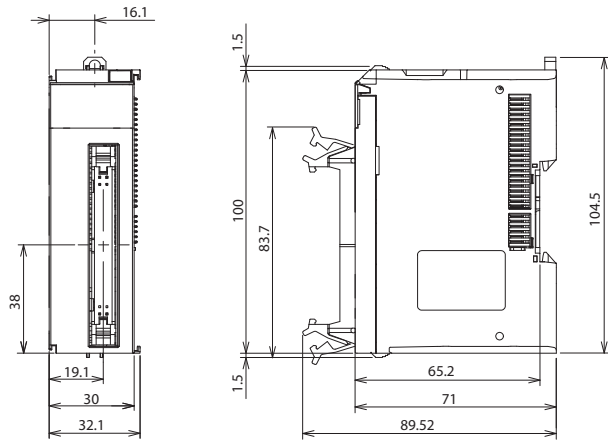

2 connectors with 20 terminals

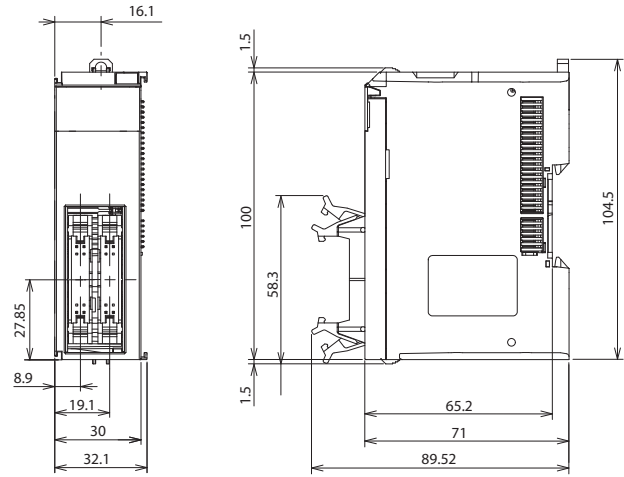

2 connectors with 34 terminals

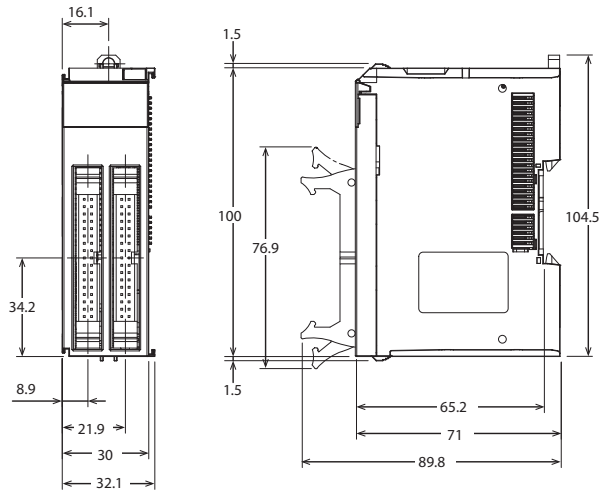

I/O unit with Fujitsu connector

1 connector with 40 terminals

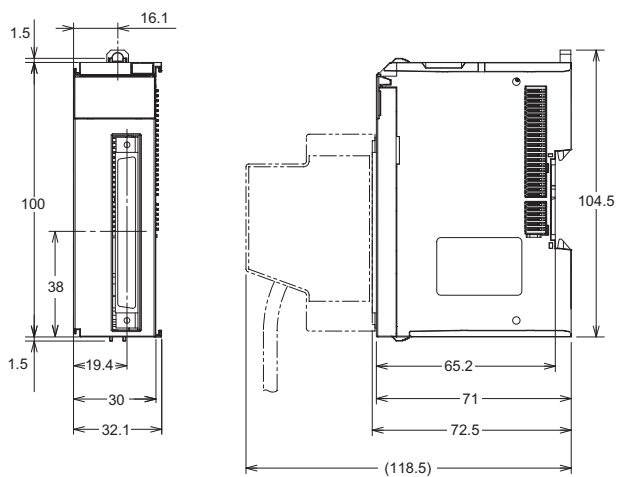

2 connectors with 24 terminals

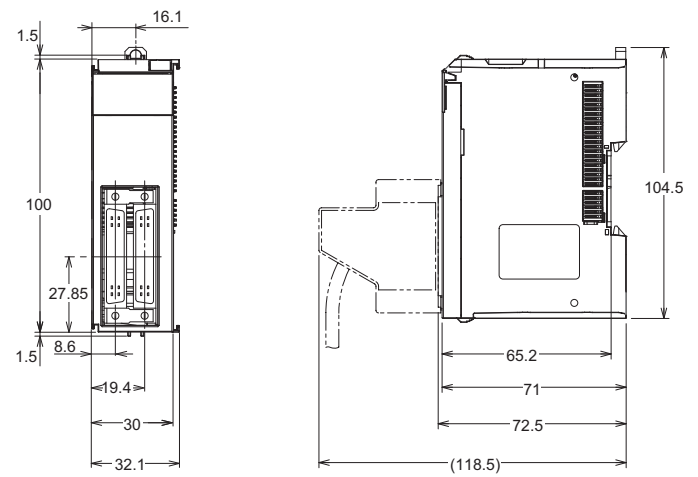

I/O unit with M3 screw terminal block

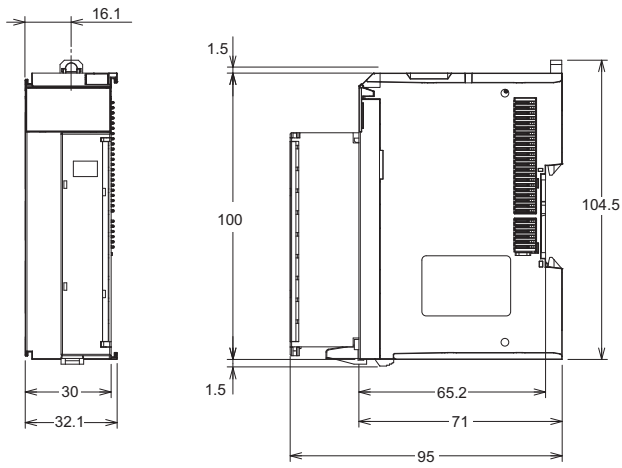

I/O unit with D-Sub connector

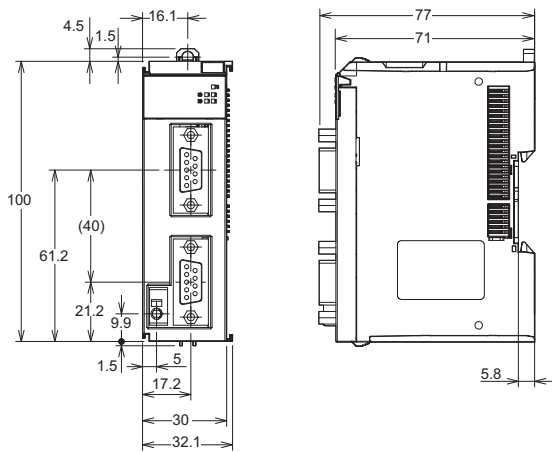

## Ordering information

### Communication coupler unit

Type	Protocol	Communications cycle in DC mode <sup>*1</sup>	Specifications	Connection	I/O power supply	Width	Model
Communication coupler	EtherCAT slave	125 to 10,000 $\mu$ s	Up to 63 I/O units Max. 1024 bytes in + 1024 bytes out Supports distributed clock	2 RJ45 ports (in + out)	10.0 A max.	46 mm	NX-ECC203
	EtherNet/IP slave		Up to 63 I/O units Max. 512 bytes in + 512 bytes out Supports local safety communication Free run I/O refresh mode only	2 RJ45 ports with built-in switch			NX-EIC202 <sup>*2</sup>

\*1. This depends on the specifications of the EtherCAT master and the unit configuration.

\*2. The NX-EIC202 communication coupler unit does not support the NX-SL3500 safety controller unit.

### IO-Link master unit

Type	No. of ports	I/O refresh method	Connection type <sup>*1</sup>	Width	Model
IO-Link master	4	Free run	Screwless push-in (NX-TBA162)	12 mm	NX-ILM400

\*1. Units with Screwless push-in connections are supplied with the appropriate terminal connector.

**Note:** For more detailed information about IO-Link master unit, refer to "IO-Link master datasheet (I191E-EN)".

### I/O unit

#### Digital I/O

Type	Channels, signal type	Performance <sup>*1</sup> , I/O refresh method	Connection type <sup>*2</sup>	Width	Model	NPN type <sup>*3</sup>
DC digital input	4 inputs, 3-wire connection	High-speed synchronous time stamp	Screwless push-in (NX-TBA122)	12 mm	NX-ID3444	NX-ID3344
		High-speed synchronous/free run	Screwless push-in (NX-TBA122)	12 mm	NX-ID3443	NX-ID3343
		Synchronous/free run	Screwless push-in (NX-TBA122)	12 mm	NX-ID3417	NX-ID3317
	8 inputs, 2-wire connection	Synchronous/free run	Screwless push-in (NX-TBA162)	12 mm	NX-ID4442	NX-ID4342
			Screwless push-in (NX-TBA162)	12 mm	NX-ID5442	NX-ID5342
	16 inputs, 1-wire connection	Synchronous/free run	M3 screw terminal block	30 mm	NX-ID5142-1	NX-ID5142-1
			1 x 20-pin MIL connector	30 mm	NX-ID5142-5	NX-ID5142-5
32 inputs, 1-wire connection	Synchronous/free run	1 x 40-pin MIL connector	30 mm	NX-ID6142-5	NX-ID6142-5	
		1 x 40-pin Fujitsu connector	30 mm	NX-ID6142-6	NX-ID6142-6	
AC digital input	4 inputs, 200-240 VAC, 50/60 Hz	Free run	Screwless push-in (NX-TBA082)	12 mm	NX-IA3117	-
DC digital output	2 outputs 0.5 A, 3-wire connection	High-speed synchronous time stamp	Screwless push-in (NX-TBA082)	12 mm	NX-OD2258	NX-OD2154
		High-speed synchronous/free run	Screwless push-in (NX-TBA122)	12 mm	NX-OD3257	NX-OD3153
	4 outputs 0.5 A, 3-wire connection	Synchronous/free run	Screwless push-in (NX-TBA122)	12 mm	NX-OD3256	NX-OD3121
			Screwless push-in (NX-TBA162)	12 mm	NX-OD3268	-
	8 outputs 0.5 A, 2-wire connection	Synchronous/free run	Screwless push-in (NX-TBA162)	12 mm	NX-OD4256	NX-OD4121
			Screwless push-in (NX-TBA162)	12 mm	NX-OD5256	NX-OD5121
	16 outputs 0.5 A, 1-wire connection	Synchronous/free run	M3 screw terminal block	30 mm	NX-OD5256-1	NX-OD5121-1
1 x 20-pin MIL connector			30 mm	NX-OD5256-5	NX-OD5121-5	
32 outputs 0.5 A, 1-wire connection	Synchronous/free run	1 x 40-pin MIL connector	30 mm	NX-OD6256-5	NX-OD6121-5	
		1 x 40-pin Fujitsu connector	30 mm	-	NX-OD6121-6	
Relay digital output	2 outputs, N.O., 2.0 A	Free run	Screwless push-in (NX-TBA082)	12 mm	NX-OC2633	-
	2 outputs, N.O. + N.C., 2.0 A		Screwless push-in (NX-TBA082)	12 mm	NX-OC2733	-
	8 outputs, N.O., 2.0 A		Screwless push-in (NX-TBA082 x 2)	24 mm	NX-OC4633	-
DC Digital I/O	16 inputs + 16 outputs, 1-wire connection + common	Synchronous/free run	2 x 20-pin MIL connector	30 mm	NX-MD6256-5	NX-MD6121-5
			2 x 24-pin Fujitsu connector	30 mm	-	NX-MD6121-6

\*1. Digital I/O performance, ON/OFF delay:

**High speed PNP/NPN input:** 100 ns/100 ns

**Standard PNP/NPN input:** 0.02 ms/0.4 ms

**AC input:** 10 ms/40 ms

**High speed PNP/NPN output:** 300 ns/300 ns

**Standard PNP output:** 0.5 ms/1.0 ms

**Standard NPN output:** 0.1 ms/0.8 ms

**Relay output:** 15 ms/15 ms

\*2. Units with Screwless push-in connections are supplied with the appropriate terminal connector. Units with MIL connectors are supplied without matching plugs.

\*3. Model codes are for PNP type signals (positive switching, 0 V common). Most models are also available as NPN type (negative switching, 24 V common). Inputs of MIL connector versions can be used as NPN or PNP.

### Analog I/O

Type	Signal type	Performance, I/O refresh method	Channels	Connection type <sup>*1</sup>	Width	Model
Analog input	4 to 20 mA single ended	1/8,000 resolution, 250 μs/channel Free run	2	Screwless push-in (NX-TBA082)	12 mm	NX-AD2203
			4	Screwless push-in (NX-TBA122)	12 mm	NX-AD3203
			8	Screwless push-in (NX-TBA162)	12 mm	NX-AD4203
	4 to 20 mA differential	1/8,000 resolution, 250 μs/channel Free run	2	Screwless push-in (NX-TBA082)	12 mm	NX-AD2204
			4	Screwless push-in (NX-TBA122)	12 mm	NX-AD3204
			8	Screwless push-in (NX-TBA162)	12 mm	NX-AD4204
			2	Screwless push-in (NX-TBA082)	12 mm	NX-AD2208
			4	Screwless push-in (NX-TBA122)	12 mm	NX-AD3208
			8	Screwless push-in (NX-TBA162)	12 mm	NX-AD4208
	±10 V single ended	1/8,000 resolution, 250 μs/channel Free run	2	Screwless push-in (NX-TBA082)	12 mm	NX-AD2603
			4	Screwless push-in (NX-TBA122)	12 mm	NX-AD3603
			8	Screwless push-in (NX-TBA162)	12 mm	NX-AD4603
±10 V differential	1/8,000 resolution, 250 μs/channel Free run	2	Screwless push-in (NX-TBA082)	12 mm	NX-AD2604	
		4	Screwless push-in (NX-TBA122)	12 mm	NX-AD3604	
		8	Screwless push-in (NX-TBA162)	12 mm	NX-AD4604	
		2	Screwless push-in (NX-TBA082)	12 mm	NX-AD2608	
		4	Screwless push-in (NX-TBA122)	12 mm	NX-AD3608	
		8	Screwless push-in (NX-TBA162)	12 mm	NX-AD4608	
Analog output	4 to 20 mA	1/8,000 resolution, 250 μs/channel Free run	2	Screwless push-in (NX-TBA082)	12 mm	NX-DA2203
			4	Screwless push-in (NX-TBA122)	12 mm	NX-DA3203
			2	Screwless push-in (NX-TBA082)	12 mm	NX-DA2205
	±10 V	1/8,000 resolution, 250 μs/channel Free run	2	Screwless push-in (NX-TBA082)	12 mm	NX-DA2603
			4	Screwless push-in (NX-TBA122)	12 mm	NX-DA3603
			2	Screwless push-in (NX-TBA082)	12 mm	NX-DA2605
			4	Screwless push-in (NX-TBA122)	12 mm	NX-DA3605
			2	Screwless push-in (NX-TBA082)	12 mm	NX-DA2608
			4	Screwless push-in (NX-TBA122)	12 mm	NX-DA3608
			8	Screwless push-in (NX-TBA162)	12 mm	NX-DA4608

\*1. Units with Screwless push-in connections are supplied with the appropriate terminal connector.

### Temperature input

Type	Signal type	Performance, I/O refresh method	Channels	Connection type <sup>*1</sup>	Width	Model
Temperature sensor input	Thermocouple type B/E/J/K/L/N/R/S/T/U/ WR5-26/PLII	0.1°C resolution, 200 ms/unit Free run	2	Screwless push-in terminal block(s), with cold junction sen- sor, calibrated individually at the factory	12 mm	NX-TS2101
			4		24 mm	NX-TS3101
			2		12 mm	NX-TS2102
			4		24 mm	NX-TS3102
			2		12 mm	NX-TS2104
	RTD type Pt100 (3wire)/Pt1000/ Ni508.4	0.01°C resolution, 10 ms/unit Free run	2	Screwless push-in (NX-TBA162) + NX-TBB162)	12 mm	NX-TS2201
			4		24 mm	NX-TS3201
			2		12 mm	NX-TS2202
			4		24 mm	NX-TS3202
			2		12 mm	NX-TS2204
4	24 mm	NX-TS3204				

\*1. Units with Screwless push-in connections are supplied with the appropriate terminal connector.

### Heater burnout detection

Type	Channels, signal type	Control output	I/O refresh method	Connection type <sup>*1</sup>	Width	Model
Heater burnout detection	4 CT inputs 4 control outputs	NPN, 12 to 24 VDC 0.1 A/point, 0.4 A/unit	Free run	Screwless push-in (NX-TBA162)	12 mm	NX-HB3101
		PNP, 24 VDC 0.1 A/point, 0.4 A/unit		Screwless push-in (NX-TBA162)		NX-HB3201

\*1. Units with Screwless push-in connections are supplied with the appropriate terminal connector.

## Position interface

Type	Channels, signal type	I/O refresh method	Connection type <sup>1</sup>	Width	Model	NPN type <sup>2</sup>
Encoder input	1 SSI encoder, 2 MHz	Synchronous/free run	Screwless push-in (NX-TBA122)	12 mm	NX-ECS112	-
	2 SSI encoders, 2 MHz		Screwless push-in (NX-TBA122)	12 mm	NX-ECS212	-
	1 incremental encoder line driver 4 MHz + 3 digital inputs (1 μs)		Screwless push-in (NX-TBA122 + NX-TBB122)	24 mm	NX-EC0142	NX-EC0132
	1 incremental encoder open collector 500 kHz + 3 digital inputs (1 μs)		Screwless push-in (NX-TBA162)	12 mm	NX-EC0122	NX-EC0112
	2 incremental encoders open collector 500 kHz		Screwless push-in (NX-TBA122)	12 mm	NX-EC0222	NX-EC0212
Pulse output	1 pulse open collector 500 kHz + 2 digital inputs + 1 digital output	Synchronous	Screwless push-in (NX-TBA162)	12 mm	NX-PG0122	NX-PG0112
	2 pulse line driver 4 MHz + 5 digital inputs per channel + 3 digital outputs per channel		1 x 34-pin MIL connector	30 mm	NX-PG0242-5	NX-PG0232-5
	4 pulse line driver 4 MHz + 5 digital inputs per channel + 3 digital outputs per channel		2 x 34-pin MIL connector	30 mm	NX-PG0342-5	NX-PG0332-5

\*1. Units with Screwless push-in connections are supplied with the appropriate terminal connector. Units with MIL connectors are supplied without matching plugs.

\*2. Model codes are for PNP type signals (positive switching, 0 V common). Most models are also available as NPN type (negative switching, 24 V common). Inputs of MIL connector versions can be used as NPN or PNP.

## Load cell input

Type	Specifications	I/O refresh method	Excitation voltage/Input range	Connection type <sup>1</sup>	Width	Model
Load cell input	1 load cell input, 125 μs conversion cycle	Synchronous/free run	5 VDC ±10%/-5 to 5 mV/V	Screwless push-in (NX-TBC162)	12 mm	NX-RS1201

\*1. Units with Screwless push-in connections are supplied with the appropriate terminal connector.

## Safety

Type	Specifications	Performance, I/O refresh method	Connection type <sup>1</sup>	Width	Model
Safety controller	FSoE protocol	For up to 1,024 safety I/O points	128 safety connections	30 mm	NX-SL3500
		For up to 256 safety I/O points	32 safety connections	30 mm	NX-SL3300
Safety input	4 inputs + 2 test outputs	Free run	Screwless push-in (NX-TBA082)	12 mm	NX-SIH400
	8 inputs + 2 test outputs		Screwless push-in (NX-TBA162)	12 mm	NX-SID800
Safety output	2 outputs, 2.0 A		Screwless push-in (NX-TBA082)	12 mm	NX-SOH200
	4 outputs, 0.5 A		Screwless push-in (NX-TBA082)	12 mm	NX-SOD400

\*1. Units with Screwless push-in connections are supplied with the appropriate terminal connector.

**Note:** For more detailed information about safety units, refer to "NX integrated safety datasheet (I183E-EN)" and "NX safety standalone datasheet (I185E-EN)".

## Communication interface unit

Type	Serial interface	No. of serial ports	Connection type <sup>1</sup>	Width	Model
Communication interface	RS-232C	1	Screwless push-in (NX-TBC162)	12 mm	NX-CIF101
		2	D-Sub 9pin connector	30 mm	NX-CIF210
	RS-422A/485	1	Screwless push-in (NX-TBC162)	12 mm	NX-CIF105

\*1. Units with Screwless push-in connections are supplied with the appropriate terminal connector.

## Power/System unit

Type	Description	Connection type <sup>1</sup>	Width	Model
NX bus power supply unit	24 VDC input, non-isolated	Screwless push-in (NX-TBC082)	12 mm	NX-PD1000
I/O power feed unit	For separation of groups, up to 4 A	Screwless push-in (NX-TBA082)	12 mm	NX-PF0630
	For separation of groups, up to 10 A	Screwless push-in (NX-TBA082)	12 mm	NX-PF0730
I/O power supply connection unit	16 × IOV	Screwless push-in (NX-TBA162)	12 mm	NX-PC0020
	16 × IOG	Screwless push-in (NX-TBA162)	12 mm	NX-PC0010
	8 × IOV + 8 × IOG	Screwless push-in (NX-TBA162)	12 mm	NX-PC0030
Shield connection unit	Grounding terminal, 16 points	Screwless push-in (NX-TBC162)	12 mm	NX-TBX01

\*1. Units with Screwless push-in connections are supplied with the appropriate terminal connector.

## Accessories

Type	Description	Connection type	Width	Model
End cover	Included with communication coupler	-	12 mm	NX-END01
Terminal block (replacement front connector)	With 8 wiring terminals (A + B)	Screwless push-in	12 mm	NX-TBA082
	With 8 wiring terminals (A + B with FG)		12 mm	NX-TBC082
	With 12 wiring terminals (A + B)		12 mm	NX-TBA122
	With 12 wiring terminals (C + D)		12 mm	NX-TBB122
	With 16 wiring terminals (A + B)		12 mm	NX-TBA162
	With 16 wiring terminals (C + D)		12 mm	NX-TBB162
	With 16 wiring terminals (A + B with FG)		12 mm	NX-TBC162
DIN rail insulation spacers	Set of 3 pcs	-	-	NX-AUX01
Terminal block coding pins	For 10 units (Terminal block: 30 pins, unit: 30 pins)	-	-	NX-AUX02
End plate	To secure the units on the DIN track	-	-	PPF-M

**Machine controller**

Name	Description	Firmware version	Model
IPC machine controller	Industrial box PC type	1.12 or higher	NY512-□
	Industrial panel PC type		NY532-□
NX7 series	CPU unit	1.13 or higher	NX701-□
	Power supply unit	-	NX-PA9001 (220 VAC)
			NX-PD7001 (24 VDC)
NJ series	CPU unit	1.13 or higher	NJ501-□
			NJ301-□
			NJ101-□
	Power supply unit	-	NJ-PA3001 (220 VAC)
			NJ-PD3001 (24 VDC)
NX1 series	CPU unit	1.13 or higher	NX1P2-□

**Note:** Please contact your OMRON sales representative for the compatibility between previous machine controller firmware versions and NX I/O units.

**Computer software**

Specifications	Model
Sysmac Studio version 1.17 or higher <sup>*1</sup>	SYSMAC-SE2□□□

\*1. Please contact your OMRON representative for compatibility between the Sysmac Studio version 1.16 or lower and NX I/O units.

ALL DIMENSIONS SHOWN ARE IN MILLIMETERS.

To convert millimeters into inches, multiply by 0.03937. To convert grams into ounces, multiply by 0.03527.