

Single-channel capacitive sensor for touch and proximity detection

Datasheet - production data

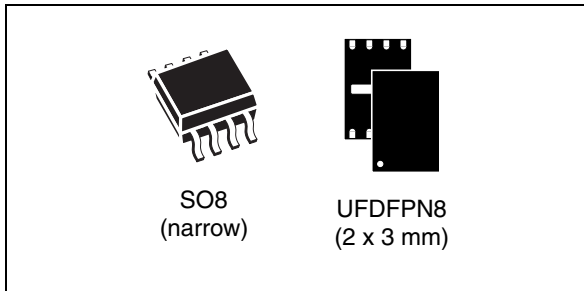

Features

- Touch and short range proximity detection
- Internal sampling capacitor
- On-chip integrated voltage regulator
- Automatic electrode tuning (AET)
- Electrode parasitic capacitance compensation (EPCC)
- Dynamic calibration (DYCAL™)
- Environment control system (ECS)
- User programmable options include:
 - Configurable output modes
 - Configurable sensitivity levels
 - Data streaming mode
 - Low power management
- Operating supply voltage: 2.3 V to 5.5 V
- Supported interface:
 - Individual key state output
 - Single wire data interface
- Operating temperature: -40 to +85 °C
- ECOPACK®2 8-pin SO and 8-pin UFDFPN packages

Applications

- Ear-face proximity detection for smart phone devices
- Companion device for navigation joystick/optical track pad
- User hand detection for Nomad equipment (tablet PC)
- Ear-head detection for MP3/walkman ear buds and Bluetooth headsets
- On/off touch sensing button such as GPS system home button
- User hands detection for mouse/keyboards
- Wall switch backlight activation on user approach and light controls on user touch

Contents

1	Description	7
2	Block diagram	8
3	Pin descriptions	9
4	STM8T ProxSense technology	11
4.1	Capacitive sensing overview	11
4.2	Charge-transfer acquisition principle	11
4.3	Internal sampling capacitor	13
4.4	Electrode parasitic capacitance compensation (EPCC)	13
5	STM8T143 processing	14
5.1	Automatic electrode tuning (AET)	14
5.2	Signal calculation and reference calibration	15
5.3	Detection and release thresholds	16
5.4	Dynamic calibration (DYCAL)	18
5.5	Environment control system (ECS)	21
5.5.1	ECS principle	21
5.5.2	ECS halt	22
5.5.3	Reference freeze and reference freeze timeout	23
5.5.4	ECS filter constant adjustment	24
5.6	Debounce filter	25
6	Device operation	26
6.1	Option byte description	26
6.2	Device operating modes	29
6.2.1	Dual output mode	29
6.2.2	Control mode	30
6.2.3	Data streaming mode	31
6.3	Output polarity	32
6.4	Power modes	33

7	Typical application diagram	34
8	Design guidelines	36
8.1	Sensitivity adjustment	36
8.1.1	PCB layout and construction	36
9	Electrical characteristics	37
9.1	Parameter conditions	37
9.1.1	Minimum and maximum values	37
9.1.2	Typical values	37
9.1.3	Typical curves	37
9.1.4	Loading capacitor	37
9.2	Absolute maximum ratings	38
9.3	Operating conditions	38
9.3.1	General operating conditions and supply characteristics	38
9.3.2	Average current consumption	39
9.3.3	I/O pin characteristics	39
9.4	Regulator and reference voltage	41
9.5	Capacitive sensing characteristics	42
9.6	Streaming mode characteristics	44
9.7	EMC characteristics	45
9.7.1	Functional EMS (electromagnetic susceptibility)	45
9.7.2	Prequalification trials	45
9.7.3	Electromagnetic interference (EMI)	45
9.7.4	Absolute maximum ratings (electrical sensitivity)	46
9.7.5	Electrostatic discharge (ESD)	46
9.7.6	Static latchup	46
10	Package characteristics	47
10.1	Package mechanical data	48
10.1.1	SO8 package mechanical data	48
10.1.2	UFDFPN8 package mechanical data	50
10.2	Package thermal characteristics	52
10.2.1	Reference document	52
11	Ordering information	53

11.1	STM8T143 ordering information scheme	53
11.2	Orderable favorite device lists	54
11.2.1	Part number option bytes	54
11.3	In-factory option byte programming service	54
11.4	Revision code on device markings	55
12	STM8T143 programming tool	59
13	Revision history	60

List of tables

Table 1.	STM8T143 pin descriptions	10
Table 2.	Option bytes	26
Table 3.	Option byte description	27
Table 4.	Pin 1 configuration	29
Table 5.	Pin 8 configuration	29
Table 6.	Data streaming frame	32
Table 7.	Voltage characteristics	38
Table 8.	Current characteristics	38
Table 9.	Thermal characteristics	38
Table 10.	Operating characteristics	38
Table 11.	Average current consumption	39
Table 12.	OUT/TOUT/DATA streaming pin characteristics	39
Table 13.	POUT/TOUT pin characteristics	40
Table 14.	CTRL pin characteristics	40
Table 15.	Regulator and reference voltage	41
Table 16.	General capacitive sensing characteristics	42
Table 17.	Internal C_S value	43
Table 18.	Implemented EPCC values (pF)	44
Table 19.	External sensing component characteristics	44
Table 20.	Data streaming timing characteristics	44
Table 21.	EMS data	45
Table 22.	EMI data	45
Table 23.	ESD absolute maximum ratings	46
Table 24.	Electrical sensitivities	46
Table 25.	SO8-lead plastic small outline - package mechanical data	48
Table 26.	UFDFPN8-lead ultra thin fine pitch dual flat - package mechanical data	50
Table 27.	Thermal characteristics	52
Table 28.	Option byte values	54
Table 29.	Device identification	55
Table 30.	Ordering information	59
Table 31.	Document revision history	60

List of figures

Figure 1.	STM8T143 block diagram.	8
Figure 2.	SO8 pinout	9
Figure 3.	UFDFPN8 pinout	9
Figure 4.	Coupling with hand increases the capacitance of the sensing electrode	11
Figure 5.	STM8T143 measuring circuitry	12
Figure 6.	Signal monitored on C _x pin.	12
Figure 7.	Automatic electrode tuning (AET).	15
Figure 8.	Signal reference and detection threshold (not detailed)	17
Figure 9.	DYCAL general operation.	18
Figure 10.	DYCAL operation with water residue	19
Figure 11.	No DYCAL	20
Figure 12.	IIR filter formula	21
Figure 13.	ECS halt	22
Figure 14.	Unwanted detection managed by the reference freeze timeout	23
Figure 15.	ECS filter K constant management.	24
Figure 16.	Data streaming frame	31
Figure 17.	Typical application schematic for Control mode	34
Figure 18.	Typical application schematic for Dual output mode	34
Figure 19.	Typical application schematic for Data streaming mode.	35
Figure 20.	Pin loading conditions.	37
Figure 21.	Data streaming timing diagram	44
Figure 22.	SO8-lead plastic small outline - package outline	48
Figure 23.	SO8 narrow recommended footprint (dimensions in mm)	49
Figure 24.	UFDFPN8-lead ultra thin fine pitch dual flat package (MLP) package outline	50
Figure 25.	UFDFPN 2 x 3 mm recommended footprint (dimensions in mm).	51
Figure 26.	STM8T143 ordering information scheme	53
Figure 27.	SO8 package marking	55
Figure 28.	UFDFPN8 package marking.	56
Figure 29.	STM8T143 programming tool	59

1 Description

The STM8T143 is a single channel, fully integrated, touch sensing capacitive sensor. It uses a ProxSense™ charge transfer capacitive acquisition method that is capable of near range proximity detection. The STM8T143 offers a state of the art capacitive sensing engine with an embedded sampling capacitor and voltage regulator allowing the overall solution cost to be reduced and improving system immunity in noisy environments. It can target a detection range up to 20 cm thanks to the electrode parasitic capacitance compensation (EPCC) feature. The EPCC automatically compensates ground parasitic capacitance sources (such as ground planes, printed circuit board tacks, and large metal objects) which significantly reduce the proximity detection range.

The application fields or typical functions with proximity features are various and include: on/off switches, replacement/enhancement, home buttons, backlighting feature on proximity for user interfaces, wakeup or control function on proximity, find-in-the-dark for lighting equipment, and companion device for battery saving in portable equipment.

The device has been designed to be used in applications where proximity is required and touch conditions can prevail for an extended period of time which may result in uncompensated drift in conventional capacitive sensors. Therefore, a process called DYCAL is implemented.

The STM8T143 is an ideal alternative, cost-effective, and extremely low power solution to replace conventional infrared optical proximity sensors. Capacitive sensing technology is not sensitive to sunlight or artificial light effects. The STM8T143 offers a much lower consumption (12 μ A range versus 100 μ A range) and a small form factor (DFN8 2*3*0.65 mm). Lastly, there is no need for a clear opening on the bezel to let light pass through.

The STM8T143 is offered in 8-pin packages and features both touch and proximity sensing outputs.

The STM8T143 touch pad can sense through almost any dielectric and thereby allows the electronics to be contained in a sealed enclosure.

Note: ProxSense™ is a trademark of Azoteq (Pty) Ltd.

2 Block diagram

Figure 1. STM8T143 block diagram

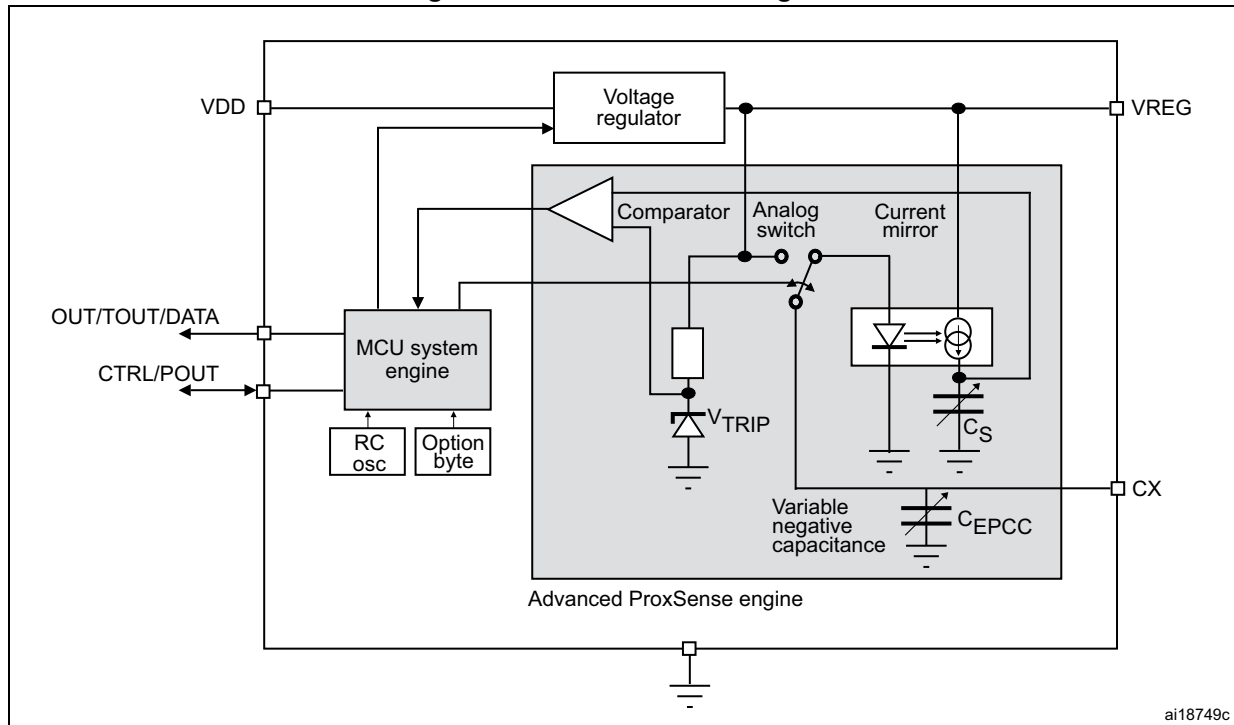

RC oscillator

The 1-MHz RC oscillator is an internal fixed frequency oscillator used to supply the clock to the MCU system engine.

Voltage regulator

The voltage regulator has an internal comparison and feedback circuit that ensures the V_{REG} voltage is kept stable and constant. The regulator requires an external smoothing capacitor.

MCU system engine

The MCU system engine controls the capacitive sensing engine and processes touch and proximity detection signals.

Advanced ProxSense engine

The advanced ProxSense engine circuitry uses a charge-transfer method to detect capacitance changes. It features:

- An analog voltage comparator
- A programmable internal sampling capacitor
- A system that allows the ground parasitic capacitance to be compensated to improve the system sensitivity. This system is called electrode parasitic capacitance compensation (EPCC).

3 Pin descriptions

Figure 2. SO8 pinout

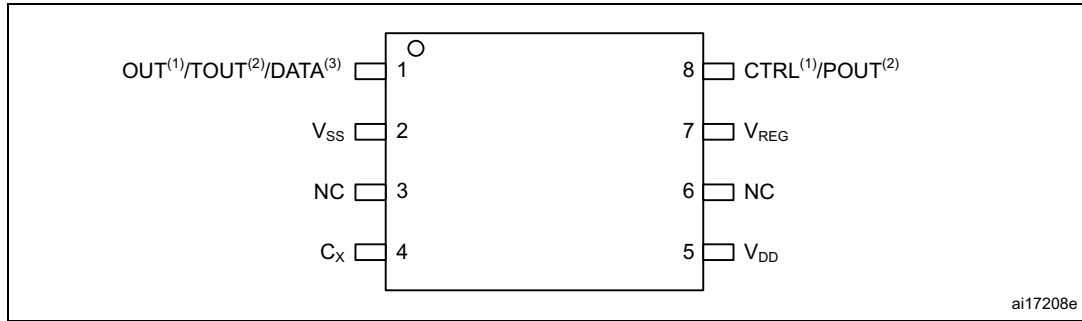
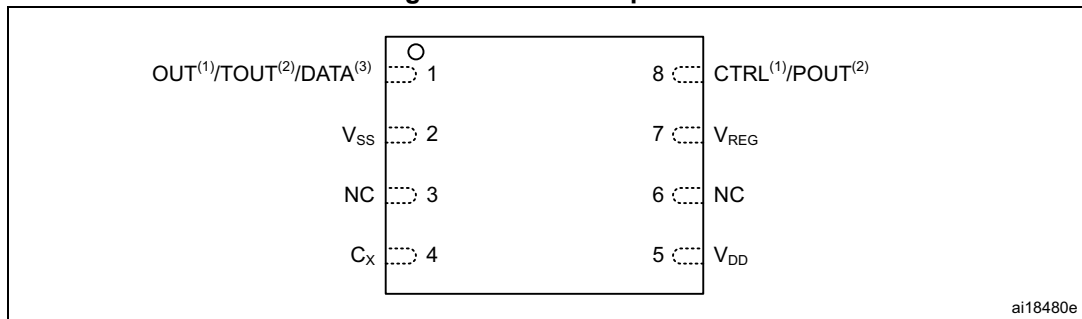

Figure 3. UDFPN8 pinout



1. Control mode
2. Dual output mode
3. Data streaming mode

Table 1. STM8T143 pin descriptions

Pin no.	Mode	Pin type ⁽¹⁾	Pin name	Pin function ⁽²⁾
1	Control mode	OD/PP	OUT	Touch or proximity output
	Dual output mode	OD/PP	TOUT	Touch output
	Data streaming mode	OD	DATA	Data streaming output
2	-	S	V _{SS}	Ground
3	-	-	NC	Not connected
4	-	SNS	C _X	Capacitive sensing channel pin to R _X
5	-	S	V _{DD}	Supply voltage
6	-	-	NC	Not connected
7	-	S	V _{REG}	Internal voltage regulator output ⁽³⁾
8	Control mode	I	CTRL	Control input
	Dual output mode	PP	POUT	Proximity output

1. S: power supply, SNS: capacitive sensing, OD: output open drain, PP: output push-pull, and I: input
2. Pin function depends on option byte configuration (please refer to [Section 6: Device operation](#))
3. Requires a low equivalent series resistance (ESR), 1µF capacitor to ground. This output must not be used to power other devices.

4 STM8T ProxSense technology

4.1 Capacitive sensing overview

A capacitance exists between any reference point and ground as long as they are electrically isolated. If this reference point is a sensing electrode, it can help to think of it as a capacitor. The positive electrode of the capacitor is the sensing electrode, and the negative electrode is formed by the surrounding area (virtual ground reference in [Figure 4](#)).

Figure 4. Coupling with hand increases the capacitance of the sensing electrode

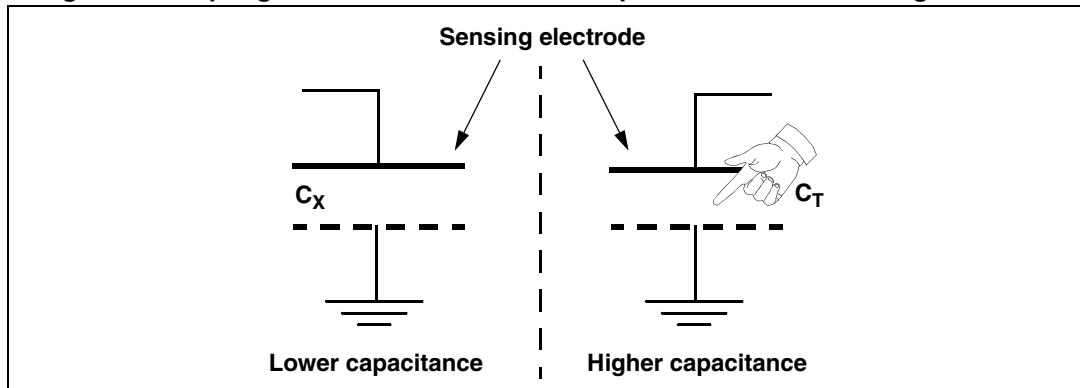

When a conductive object is brought into proximity of the sensing electrode, coupling appears between them, and the capacitance of the sensing electrode relative to ground increases. For example, a human hand raises the capacitance of the sensing electrode as it approaches it. Touching the dielectric panel that protects the electrode increases its capacitance significantly.

4.2 Charge-transfer acquisition principle

To measure changes in the electrode capacitance, STM8T devices employ bursts of charge-transfer cycles.

The measuring circuitry is connected to the C_X pin. It is composed of a serial resistor R_X plus the sensing electrode itself of equivalent capacitance C_X (see [Figure 5](#)). The sensing electrode can be made of any electrically conductive material, such as copper on PCBs, or transparent conductive material like Indium Tin Oxide (ITO) deposited on glass or Plexiglas. The dielectric panel usually provides a high degree of isolation to prevent electrostatic discharge (ESD) from reaching the STM8T touch sensing controller. Connecting the serial resistor (R_X) to the C_X pin improves ESD immunity even more.

Figure 5. STM8T143 measuring circuitry

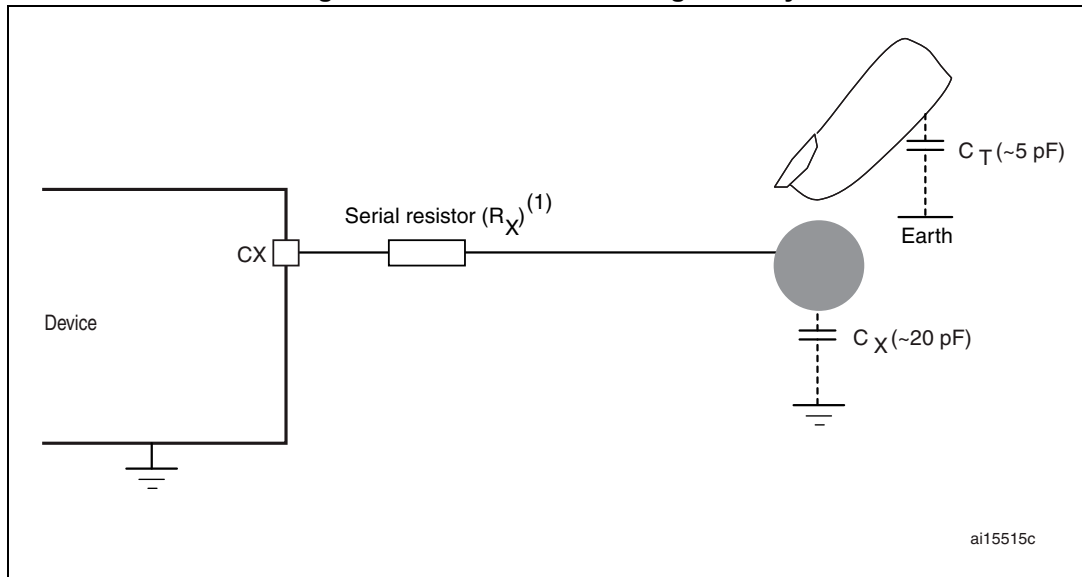

1. R_X must be placed as close as possible to the device.

The principle of charge transfer is to charge the electrode capacitance (C_X) using a stable power supply. When C_X is fully charged, part of the accumulated charge is transferred from C_X to an internal sampling capacitance, referred to as C_S . The transfer cycle is repeated until the voltage across the sampling capacitor C_S reaches the end of acquisition reference voltage (V_{TRIP}). The change in the electrode capacitance, caused by the presence or absence of the human body, is detected by measuring the number of transfer cycles composing a burst (see [Figure 6](#)).

Throughout this document the following naming conventions apply:

- The charge transfer period ($t_{TRANSFER}$) refers to the charging of C_X and the subsequent transfer of the charge to C_S .
- The burst cycle duration (t_{BURST}) is the time required to charge C_S to V_{TRIP} . The burst count is the number of charge transfer periods ($t_{TRANSFER}$) during one t_{BURST} cycle.
- The sampling period ($t_{SAMPLING}$) is the acquisition rate.

Figure 6. Signal monitored on C_X pin

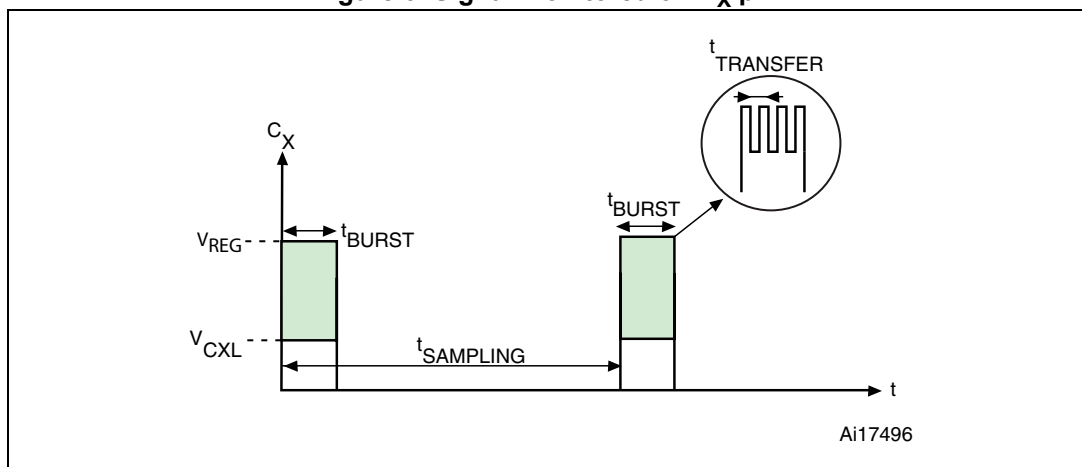

4.3 Internal sampling capacitor

To reduce the application cost and increase the device flexibility, the STM8T143 features several internal sampling capacitors to fit a wide range of applications.

4.4 Electrode parasitic capacitance compensation (EPCC)

The implementation of an electrode pad in a system always induces parasitic capacitances through tracks and surrounding components. The electrode parasitic capacitance is the residual capacitance between electrode and ground when no finger is present.

The EPCC is an internal hardware circuitry that compensates part of the electrode parasitic capacitance to improve the capacitive sensing channel sensitivity.

5 STM8T143 processing

The STM8T143 device is designed to ensure reliable operation whatever the environment and operating conditions. To achieve this high level of robustness, dedicated processing have been implemented:

- Automatic electrode tuning (AET)
- Signal and reference calibration
- Detection and release thresholds
- Dynamic calibration (DYCAL)
- Environment control system (ECS)
- Debounce filter
- Host control input

5.1 Automatic electrode tuning (AET)

AET is a sophisticated technology implemented in the STM8T143 device. It optimizes the performance of the device in a wide range of applications and environmental conditions.

AET algorithm automatically adjusts the internal C_S capacitor and EPCC parameters to optimize system performance. Please refer to:

- [Table 17: Internal CS value](#) for possible resulting values of this internal sampling capacitance
- [Table 18: Implemented EPCC values \(pF\)](#) for possible values of the EPCC capacitance.

The principle is to select an internal C_S capacitor and EPCC to obtain a burst count in a predefined range of AET target value ± 256 burst counts.

At device startup, C_S is selected to reach the nearest signal burst count value to a “gain target value”. Then, the EPCC hardware subtracts an increasing capacitance value until a “AET target value” is reached. During normal device operation, the EPCC hardware subtracts from the electrode capacitance (C_X), the compensation capacitance value determined during the calibration phase.

This automatic system adaptation allows the same burst count number to be reached regardless of the application electrode and surrounding.

The AET gain can be adjusted by selecting the gain target value through the “Gain target” option bits.

The AET algorithm is executed whenever the device starts-up and during device operation when the reference exits burst count range.

During the AET processing (t_{AET}), proximity and touch events cannot be detected (please refer to [Table 6: Data streaming frame](#)). In Data streaming mode, the AET activity is reported and the internal C_S and EPCC values can be monitored (see [Section 6.2.3: Data streaming mode](#)).

Figure 7. Automatic electrode tuning (AET)

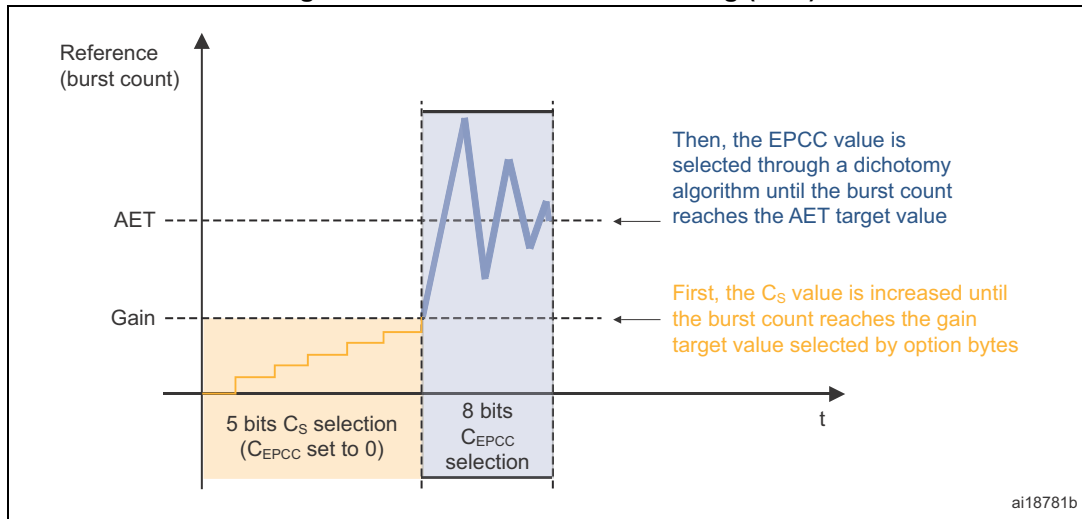

1. For the AET and gain target values, please refer to [Table 16: General capacitive sensing characteristics](#).

5.2 Signal calculation and reference calibration

The capacitance change, induced by the presence of a finger or a hand in the device detection area, is sensed by the variation in the number of charge transfer pulses composing the burst. The number of charge transfer pulses is called “burst count”. The burst count is filtered against the noise and compared to a “reference” to determine if there is a touch/proximity detection. Please refer to [Section 5.5: Environment control system \(ECS\)](#) for more details about the filtering process.

The reference is calculated at device startup during the calibration phase by averaging the first 44 measurements before normal device operation.

Then, the environment control system takes care of the reference slow evolution over time.

5.3 Detection and release thresholds

During the detection operation, after calibration is over, the STM8T143 switches between three operating states: *no detection*, *proximity detection*, and *touch detection*. The switch between these states is driven by the difference between the signal and the reference.

The system goes from *no detection* to *proximity detection* state when the (reference - signal) is higher than the proximity threshold (PTh). In this state, the ECS is halted and the reference is frozen.

The system goes from *no detection* or *proximity detection* state to *touch detection* state when the (reference - signal) is higher than the touch threshold (TTh). When this happens, the reference value is changed to reflect the touch state after the delay t_{DYCAL} . This process is called dynamic calibration (DYCAL).

The system goes from the *touch detection* to *no detection* state when the (signal - reference) goes above the release threshold (RTh). At this point, another DYCAL occurs for the reference to represent the untouched state again.

For higher flexibility, several proximity and touch detection thresholds are available and independently selectable through option byte: one PTh and one TTh.

- The touch thresholds allow the touch sensitivity to be adapted to the panel thickness and the electrode sensitivity.
- The proximity thresholds allow the STM8T143 device to adapt to various surroundings and to tune the detection distance.

The release threshold is a ratio of the touch threshold noted (TTh). TTh is selected by the “touch detection threshold” option bits. The ratio is selected by the “release threshold ratio” option bits.

A time filtering, similar to the debouncing of the mechanical switches, is applied to avoid noise induced detections.

Please refer to [Section 5.6: Debounce filter](#) for operation details.

[Figure 8](#) simplifies the proximity and touch detection event according to the signal variation “ Δ (signal)”. The Δ (signal) is the absolute value of the reference minus the signal.

Figure 8. Signal reference and detection threshold (not detailed)

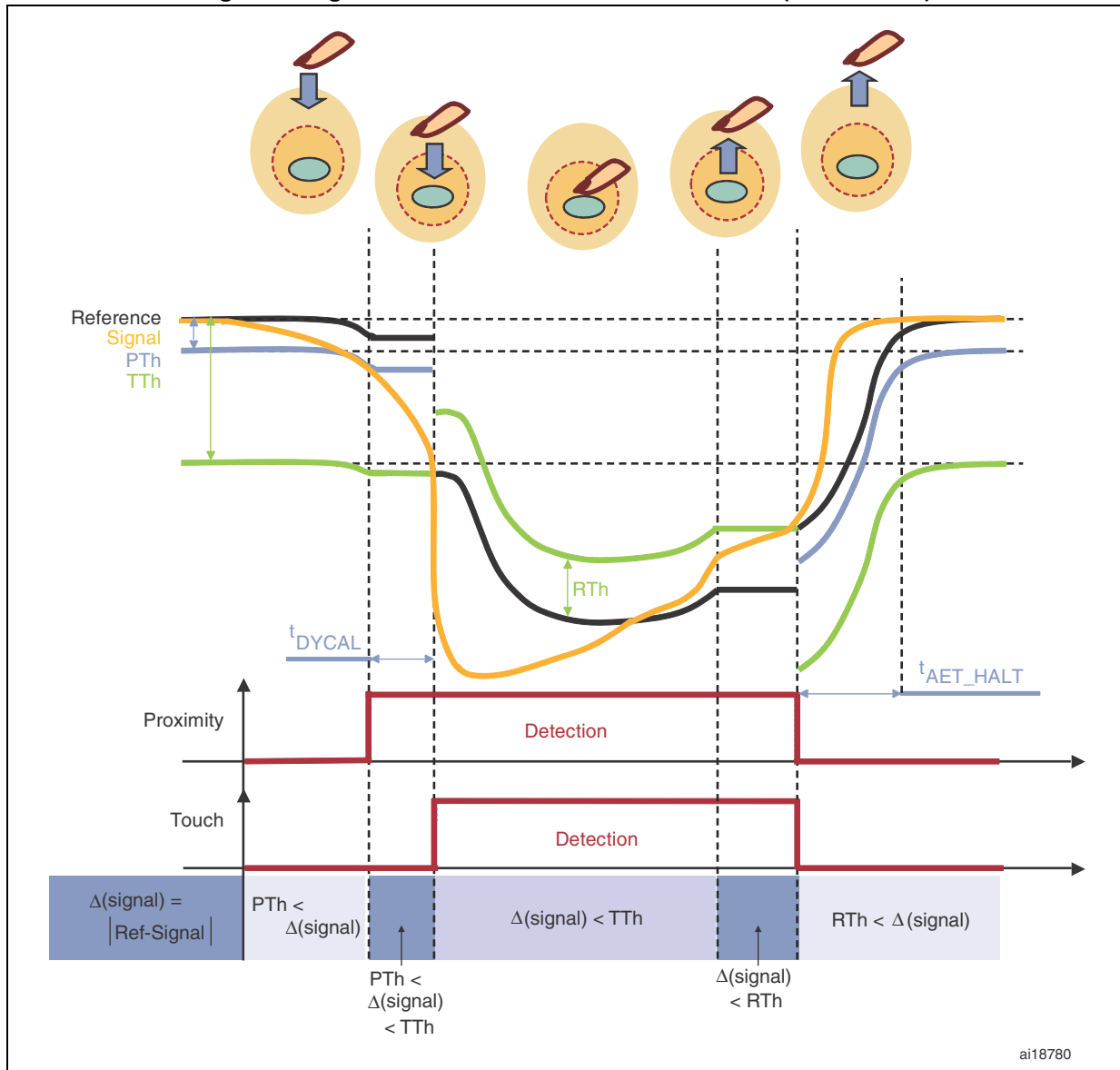

1. t_{AET_HALT} = AET halt period after end of detection.

5.4 Dynamic calibration (DYCAL)

The STM8T143 DYCAL process is based on a dynamic threshold and reference management which allows tracking of slow environmental changes even when the sensor is in touch state. A low threshold is used to detect the proximity of an object, with a higher threshold for touch detection. DYCAL is performed when a touch condition is detected for longer than a certain period (t_{DYCAL}). When a release condition occurs, the DYCAL operation is performed instantaneously. Figure 9 represents the DYCAL operation for the touch event (DYCAL_T) and for the release event (DYCAL_R).

After the DYCAL_R event, the AET process is frozen for a t_{AET_HALT} delay.

Figure 9. DYCAL general operation

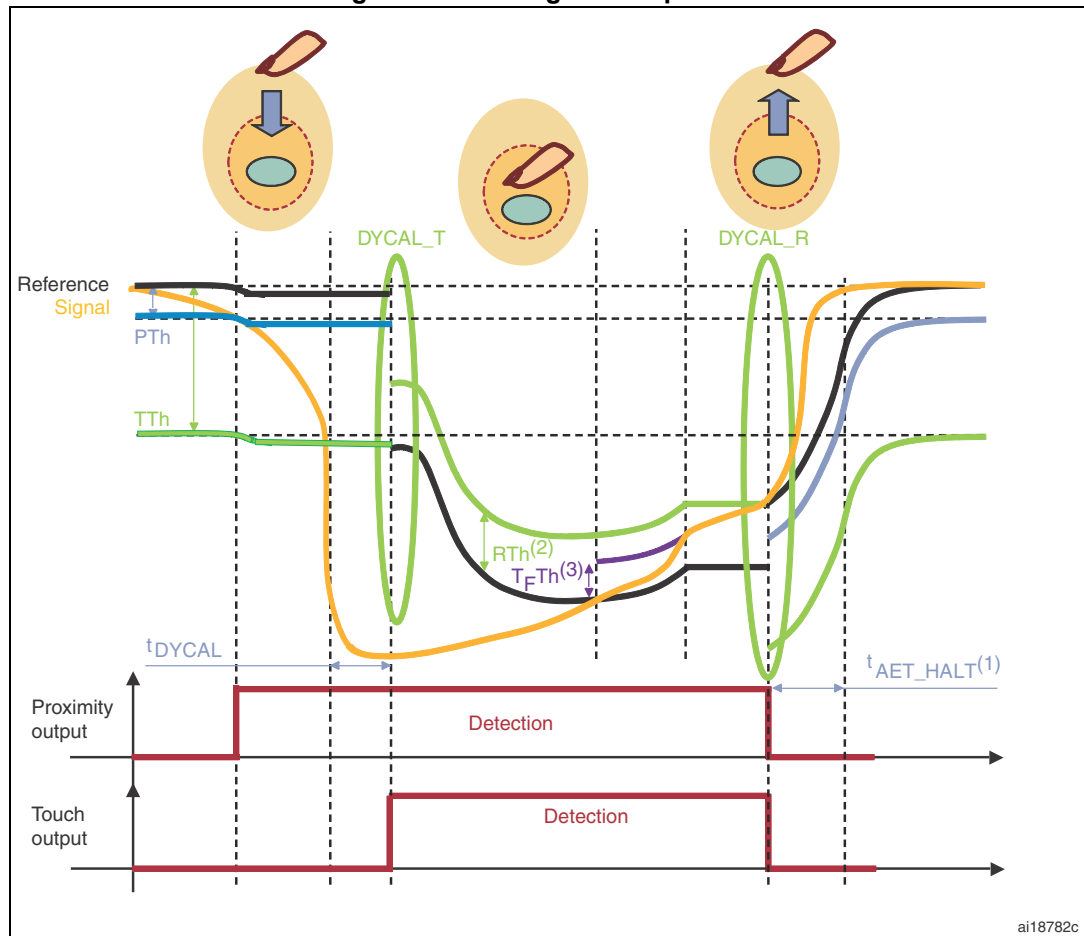

1. t_{AET_HALT} = AET halt period after end of detection.
2. The release threshold (RTh) is a ratio of the touch threshold (TTh). TTh is selected by the "touch detection threshold" option bits (TTh). The ratio is selected by the "release threshold ratio" option bits.
3. T_{FTh} = Touch freeze threshold. Please refer to [Table 16: General capacitive sensing characteristics](#) and [Figure 12: IIR filter formula](#) for the T_{FTh} description.
4. In touch condition, the ECS allows the reference to adapt a slow signal variation change.

Figure 10 is an example of how the system behaves with a water residue when it is managed by DYCAL.

Figure 10. DYCAL operation with water residue

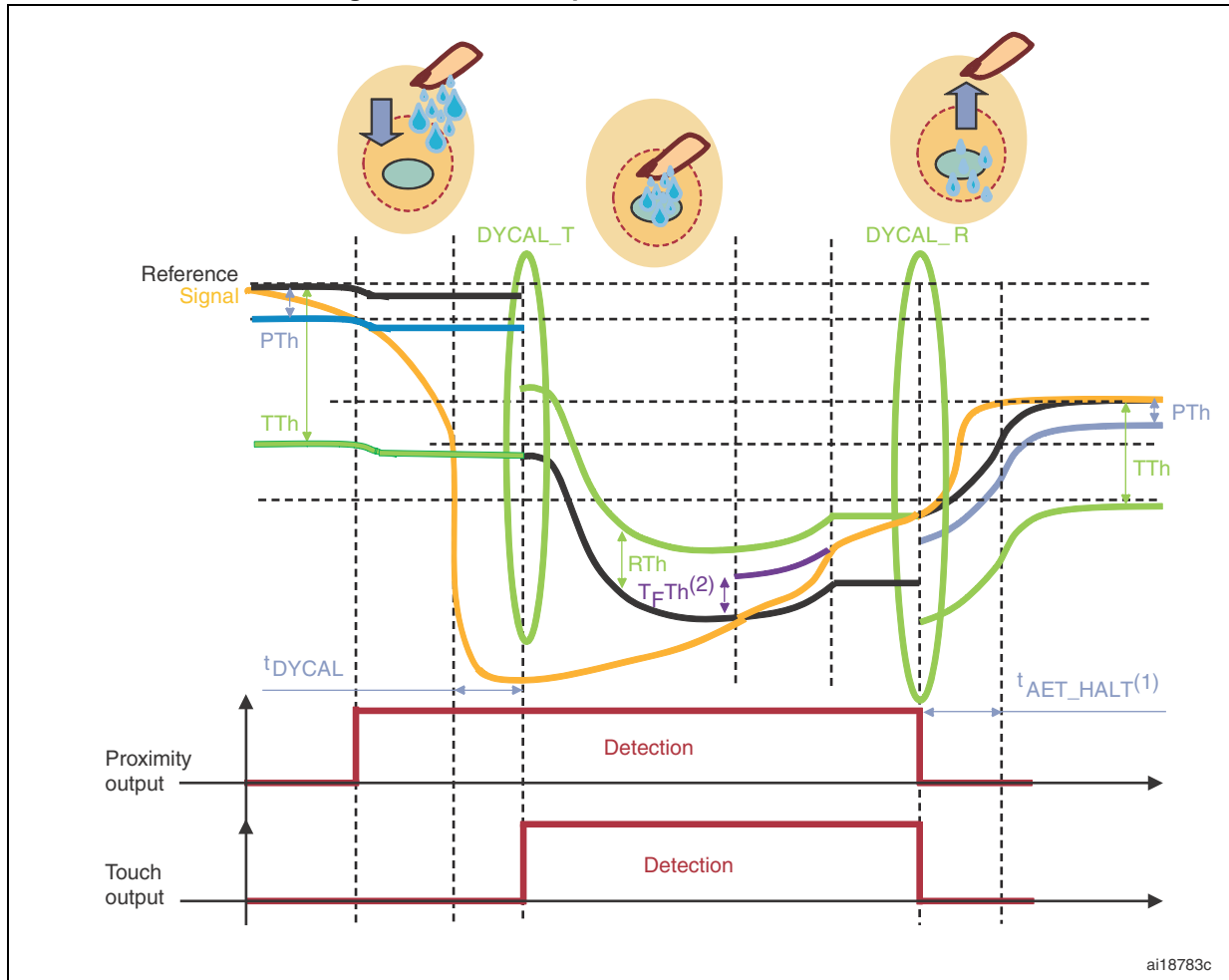

ai18783c

1. t_{AET_HALT} = AET halt period after end of detection.
2. T_{FTh} = Touch freeze threshold. Please refer to [Table 16: General capacitive sensing characteristics](#) and [Figure 12: IIR filter formula](#) for the T_{FTh} description.

Figure 11 is an example of how the system behaves with a water residue if the system is not managed by DYCAL.

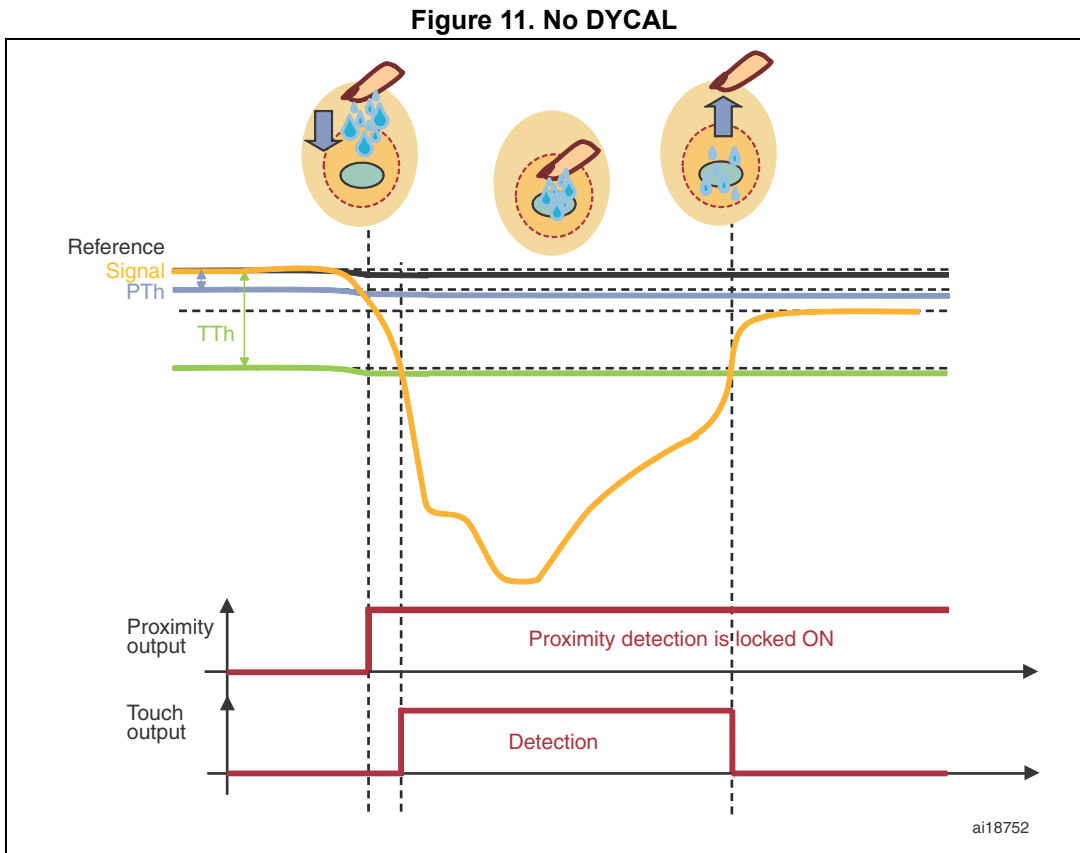

5.5 Environment control system (ECS)

5.5.1 ECS principle

The acquired signal value of the capacitive sensing channel increases or decreases according to environmental conditions such as temperature, power supply, moisture, and surrounding conductive objects. The STM8T143 includes a built-in digital infinite impulse response (IIR) filter capable of tracking slow changes in the environment. It is called the environment control system (ECS). This is a low pass filter with a gain of one. The filter makes the reference follow slow changes of the signal while fast changes are recognized as a touch or proximity.

Figure 12. IIR filter formula

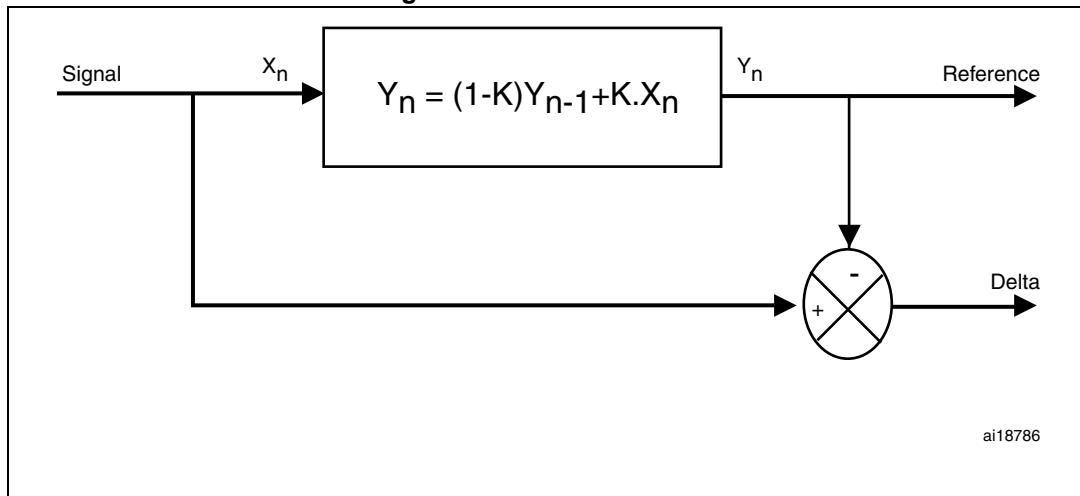

Note: *If a touch or proximity is detected, the ECS is disabled for the duration of the reference freeze timeout. In this case, $Y_n = Y_{n-1}$. As soon as the reference freeze times out or the detection ends, the filter is set as active again.*

5.5.2 ECS halt

As soon as a proximity detection is triggered, the ECS should be halted otherwise the ECS considers the signal variation due to the user action as an environment change. In such a case, the ECS adapts to the new conditions until the reference reaches the current signal level generated by the user. This leads to a detection loss as described in [Figure 13](#).

Figure 13. ECS halt

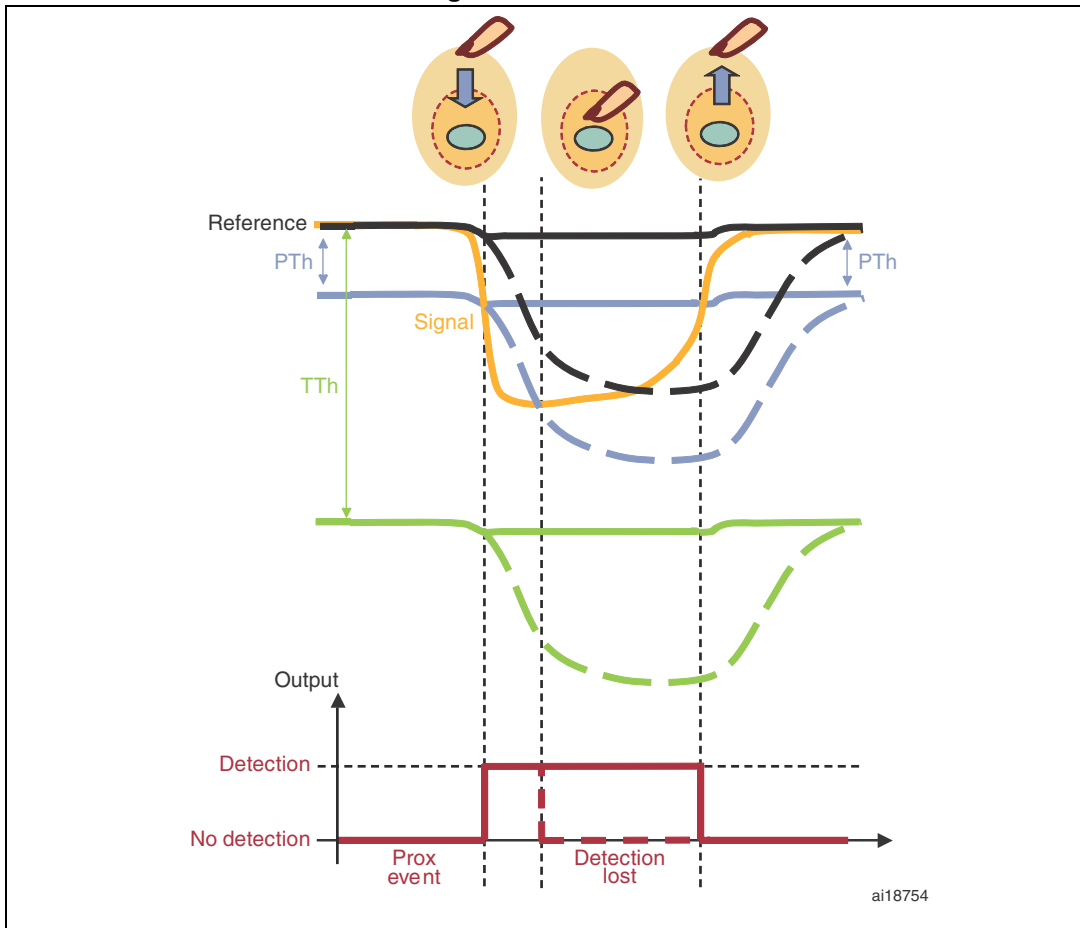

Note: 1 The dashed lines in [Figure 13](#) represent the reference and thresholds if ECS is not halted. In this case, detection is lost before the user exits the electrode detection area. The plain lines represent normal device processing with the ECS stop.

5.5.3 Reference freeze and reference freeze timeout

To prevent an object under detection from influencing the reference value, the ECS is halted as soon as a proximity detection happens: $P_{Th} < \Delta(\text{signal}) < T_{Th}$. Consequently, the reference is frozen.

In order to recover from a sudden environment change, the reference freeze ends after a maximum programmable delay called the “reference freeze timeout” (t_{RFT}).

When a detection lasts longer than the t_{RFT} , a recalibration process occurs. The recalibration consists of setting the reference to the current burst count value minus 8. Then, ECS is re-enabled and the reference moves along the signal. After a period of time that depends on the signal variation speed, the difference between the signal and the reference becomes smaller than the detection threshold and the device reports no detection. The process delay after the timeout, to get the reference aligned with the current signal, is called the recalibration time (t_{RECAL}).

Figure 14 describes the situation where an unwanted detection is solved by the reference freeze timeout. The left-hand side of the image (Reference freeze timeout enabled) shows the reference freeze timeout configured to launch a calibration if water droplets are poured onto the electrode. The droplet capacitance is not sufficient to make the device enter into touch detection but it is enough to trigger a proximity detection. If the proximity detection caused by the droplets lasts longer than the reference freeze timeout delay, the device recalibrates to the new “wet” environment. Consequently, the detection output is cleared. The right-hand side of the image (Infinite reference freeze timeout) shows the device behavior when the reference freeze timeout is disabled. The device leaves proximity detection only after the droplets are removed.

Figure 14. Unwanted detection managed by the reference freeze timeout

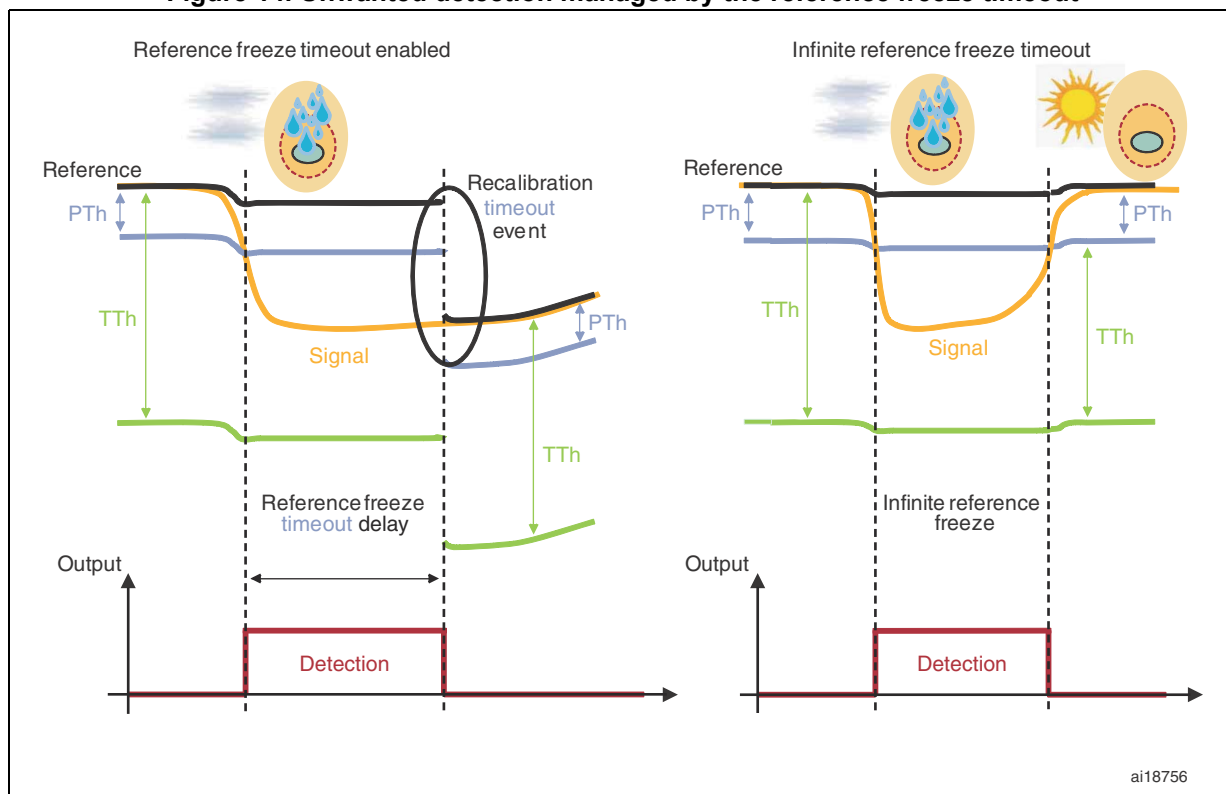

5.5.4 ECS filter constant adjustment

To track the environmental changes more accurately and to manage the detection occurrence more efficiently, different ECS filter K co-efficient values are set according to the signal range and detection state. *Figure 15: ECS filter K constant management* provides the filter K co-efficient value in different situations.

Figure 15. ECS filter K constant management

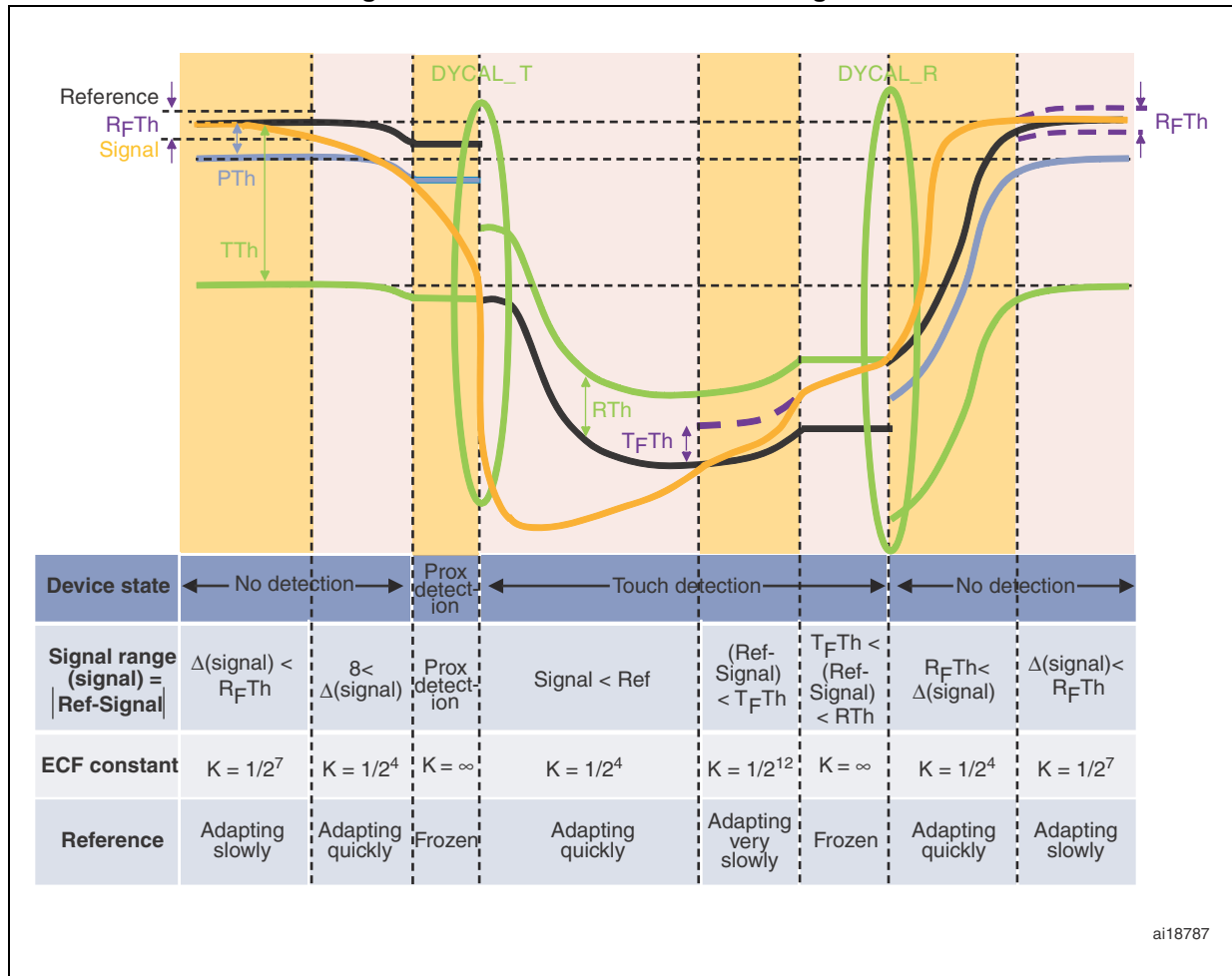

ai18787

5.6 Debounce filter

The purpose of the debounce filter mechanism is to reduce the effects of noise on the touch and proximity detection. Debouncing is applied to acquisition samples to filter undesired abrupt changes. The principle is to wait for several consecutive acquisitions with the signal on the same side of a threshold before reporting the change in detection state induced by this threshold crossing.

The number of consecutive detection debounce counts (DDC) and end of detection debounce counts (EDDC) needed to identify a proximity/touch detection are defined in [Section 9.5: Capacitive sensing characteristics on page 42](#).

6 Device operation

The STM8T143 can be configured through a set of user-selectable one-time programmable (OTP) option bytes. These options can be used in their default (unconfigured) state or set for specific applications. For large orders, preconfigured devices are available (please refer to [Section 11: Ordering information](#)).

The available options include:

- Dual output, Control, or Data streaming mode
- Output polarity
- Touch and proximity detection thresholds
 - Eight selectable detection thresholds for touch detection
 - Four selectable detection thresholds for proximity detection
- Control type
 - Halt conversion control
 - Reference freeze control
- Reference freeze timeout

6.1 Option byte description

A set of tools is supplied by STMicroelectronics to program the user OTP options for prototyping purposes. Please refer to [Section 12: STM8T143 programming tool](#) for more details.

Note: Devices which are not yet programmed (also called blank devices) are delivered with all bits set to '0'.

Table 2. Option bytes

Option byte no.	Option bits								Factory default setting
	Bit 7	Bit 6	Bit 5	Bit 4	Bit 3	Bit 2	Bit 1	Bit 0	
OPT2	Reserved		Output type ⁽¹⁾	Release threshold ratio	Gain target			Reserved	0x00
OPT1	Data streaming mode	Low power mode	Reference freeze timeout		Dynamic calibration delay	Reserved	Dual output/Control mode	0x00	
OPT0	Touch detection threshold			Proximity detection threshold	Reserved	Output polarity	Control type	0x00	

1. Used only in Control mode.

Table 3. Option byte description

Option byte no.	Description
OPT2	Bits [7:6]: Reserved, must be cleared
	Bit 5: Output type in Control mode (see Section 6.2.2: Control mode) 0: Proximity output 1: Touch output
	Bit 4: Release threshold ratio 0: 75 % 1: 87.5 %
	Bits [3:1]: Gain target 000: 200 001: 250 010: 300 011: 350 100: 400 101: 550 110: 700 111: 850
	Bit 0: Reserved, must be cleared
OPT1	Bit 7: Data streaming mode (see Section 6.2.3: Data streaming mode) 0: Disabled 1: Enabled
	Bits [6:5]: Low power mode (see Section 6.4: Power modes) 00: Normal power mode 01: Low power mode 1 10: Low power mode 2 11: Low power mode 3
	Bits [4:3]: Reference freeze timeout t_{RFT} (see Section 5.6: Debounce filter) 00: Infinite 01: 18 s 10: 60 s 11: 3 s
	Bit 2: Dynamic calibration delay (t_{DYCAL}) 0: 250 ms 1: 1 s
	Bit 1: Reserved, must be cleared
	Bit 0: Dual output/Control mode (see Section 6.2.1: Dual output mode) 0: Pin 8 in Control input mode 1: Pin 8 in Proximity output mode

Table 3. Option byte description (continued)

Option byte no.	Description
OPT0	Bits [7:5]: Touch detection threshold (TTh) 000: 40 001: 60 010: 100 011: 200 100: 360 101: 500 110: 700 111: 900
	Bit [4:3]: Proximity detection threshold (PTh) 00: 4 01: 8 10: 16 11: 32
	Bit 2: Reserved, must be cleared
	Bit 1: Output polarity (see Section 6.3: Output polarity) ⁽¹⁾ 0: Active low 1: Active high
	Bit 0: Control type (see Section 6.2.2: Control mode) 0: Halt conversion control 1: Reference freeze control

1. Effective only when Data streaming mode is disabled

6.2 Device operating modes

The STM8T143 device provides three operating modes:

- Dual output mode
- Control mode
- Data streaming mode

These modes are selected through the option bytes.

6.2.1 Dual output mode

The device is configured by default in Control mode. The Dual output/Control mode bit allows the user to configure pin 8 of the device in Control input or Proximity output.

When Dual output mode is selected, pin 8 becomes the proximity output while pin1 is the touch output.

Table 4. Pin 1 configuration

Pin 1 configuration	Data streaming mode	Dual output/Control mode	Output type	Output polarity
	OPT1 bit 7	OPT1 bit 0	OPT2 bit 5	OPT0 bit 1
DATA pin Open drain output	1	x	x	x
Proximity output Open drain output, active low	0	0	0	0
Proximity output Push-pull output, active high	0	0	0	1
Touch output Open drain output, active low	0	0	1	0
Touch output Push-pull output, active high	0	0	1	1
Proximity output Open drain output, active low	0	1	x	0
Proximity output Push-pull output, active high	0	1	x	1

Table 5. Pin 8 configuration

Pin 8 configuration	Dual output/Control mode	Control type	Output polarity
	OPT1 bit 0	OPT0 bit 0	OPT0 bit 1
Halt control input	0	0	x
ECS control input	0	1	x
Proximity output Push-pull output, active low	1	x	0
Touch output Push-pull output, active high	1	x	1

6.2.2 Control mode

In Control mode, pin 8 can be used to halt the conversion or to freeze the reference (refer to [Section 5.4: Dynamic calibration \(DYCAL\)](#)).

Halt conversion control mode

When the conversion is halted, the device is in low power consumption state (see device electrical characteristics). In this state, the CTRL pin can be used to manage the power consumption and/or control the acquisition to synchronize the sampling burst with external events. This can be useful, for example, to halt acquisitions during noisy operations or to synchronize an acquisition with the noise period.

When the CTRL pin is tied high for longer than t_{CTRL} , the charge conversion cycle is halted, once the current conversion has been completed. The device remains in this halt mode until the CTRL line is tied low again. An automatic recalibration is performed directly after the CTRL pin is released to compensate for any environmental changes which might have occurred during the halt duration.

Reference freeze control mode

In this mode, the device reference evolution can be frozen according to the CTRL pin state. The CTRL pin has precedence over the configuration bits selected for the reference freeze timeout.

This function can be used to implement user-dedicated ECS management.

When the CTRL pin is tied high for longer than t_{CTRL} , the filter is halted until this pin is tied low.

If the host freezes the reference at device startup, the calibration starts after the reference freeze is released.

Forced recalibration

Generating a pulse of $t_{recal_control}$ duration on the CTRL pin recalibrates the reference. The ECS is reset, clearing the output state. Please refer to [Table 16: General capacitive sensing characteristics](#) for $t_{recal_control}$ constraints.

If the signal value is outside its allowable range, the device forces an AET process event. (refer to [Section 5.1: Automatic electrode tuning \(AET\)](#))

6.2.3 Data streaming mode

The STM8T143 can stream data to allow designers fine tune the application and device settings. Data streaming may also be used by an MCU to control events or to further process the results obtained from STM8T143 devices. Data streaming is performed using a 1-wire communication data protocol on the data streaming output pin. When Data streaming mode is enabled, the OUT function is no longer accessible.

Data streaming protocol

The data streaming output is open drain. *Figure 16* illustrates the communication protocol for initializing and sending data using a 1-wire communication protocol.

1. Communications is initiated by a START bit.
2. Following the START bit, a synchronization byte (0xAA) is sent. This byte can be used by the MCU for clock synchronization.
3. Following the synchronization byte, the data bytes are sent with the MSB first.
4. Each byte sent is preceded by a START bit; a STOP bit follows every byte.
5. The STOP bit does not have a defined period.

Figure 16. Data streaming frame

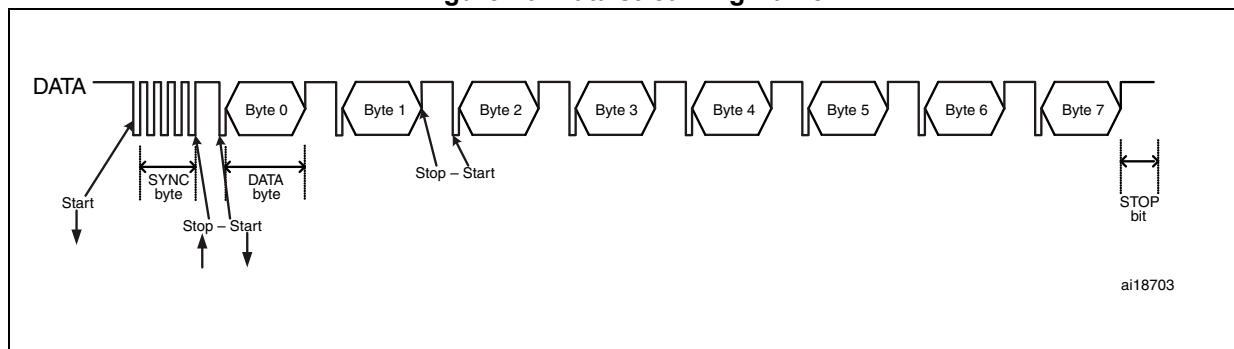

Data streaming is initiated by the STM8T143. When data streaming is enabled, a frame is sent after each charge cycle. Therefore, the acquisition is not disturbed by the communication itself.

Frame format

The content of the data frame is described in [Table 6](#).

Table 6. Data streaming frame

Byte #	Bit	Description
0	[7:0]	Signal burst count (MSB)
1	[15:8]	Signal burst count (LSB)
2	[23:16]	Reference burst count (MSB)
3	[31:24]	Reference burst count (LSB)
4	39	AET processing
	38	Proximity event detected
	37	Touch event detected
	36	OUT state indication
	35	Reserved
	34	Reserved
	33	Reserved
	32	Reserved
5	47	ICS bit 2
	46	ICS bit 1
	45	ICS bit 0
	44	EPCC bit 4
	43	EPCC bit 3
	42	EPCC bit 2
	41	EPCC bit 1
	40	EPCC bit 0
6	[55:54]	Reserved
	53	EPCC bit 5
	52	Touch threshold bit 2
	51	Touch threshold bit 1
	50	Touch threshold bit 0
	49	Proximity threshold bit 1
48	Proximity threshold bit 0	
7	[63:56]	Frame counter

6.3 Output polarity

The polarity can be chosen to define POUT and TOUT active state during a detection event such as high or low.

When the device is configured in output active low, pin 8 is in open drain configuration. When the device is configured in output active high, pin 8 is in push-pull configuration.

6.4 Power modes

The STM8T143 device offers four power modes which are specifically designed for battery applications:

- Normal power mode
- Low power mode 1
- Low power mode 2
- Low power mode 3

The difference between the four power modes is the t_{SAMPLING} time (see [Table 16: General capacitive sensing characteristics](#)). By selecting low power modes, extra delays are interlaced between bursts resulting in a longer t_{SAMPLING} period. This improves the device current consumption at the expense of a longer response time.

7 Typical application diagram

Figure 17. Typical application schematic for Control mode

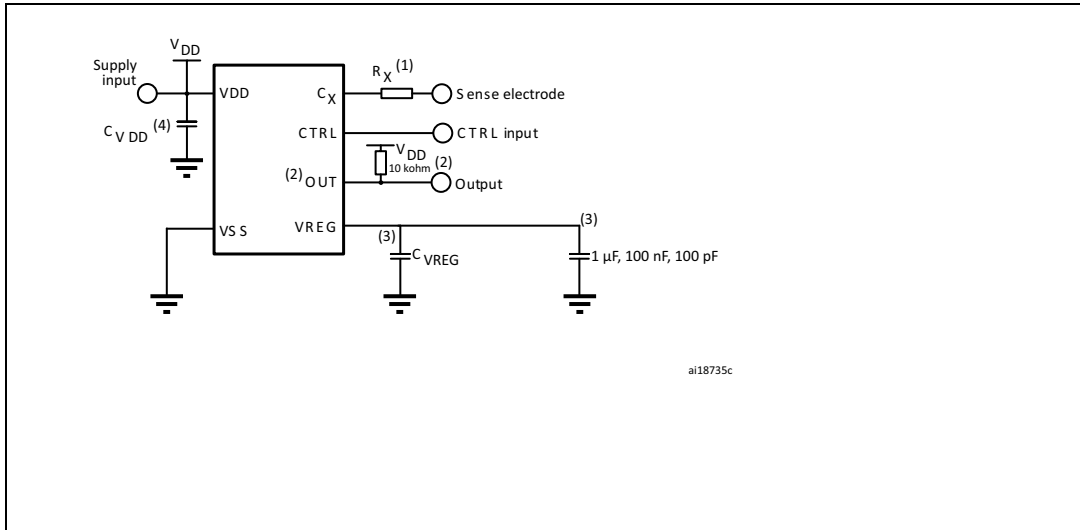

1. R_X is optional for added ESD protection
2. Active low open drain output pin or push-pull active high
3. Keep track as short as possible
4. C_{VDD} is optional for added IC stability
5. Please refer to [Table 8: Current characteristics](#) for the maximum output load drive current capability

Figure 18. Typical application schematic for Dual output mode

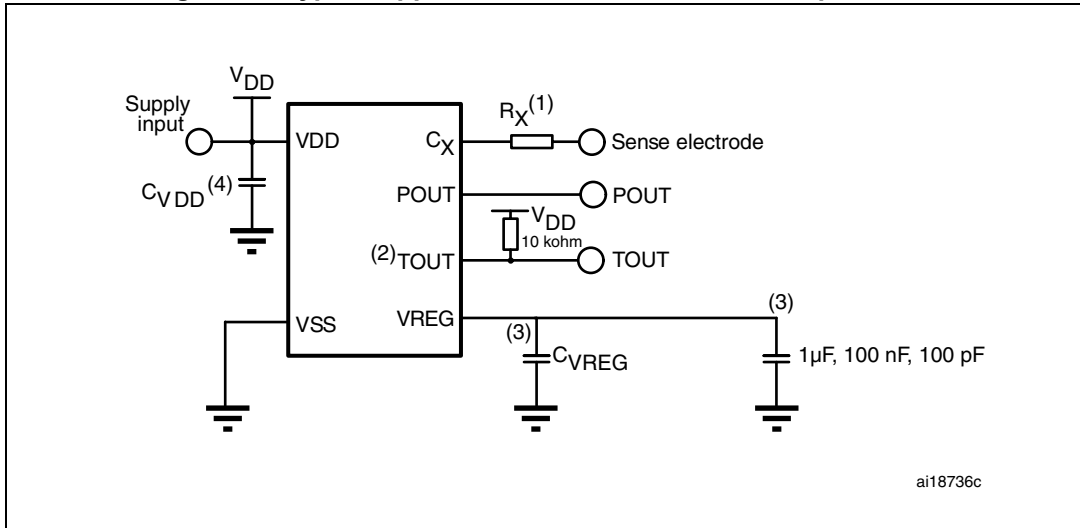

1. R_X is optional for added ESD protection
2. Active low open drain output pin or push-pull active high.
3. Keep track as short as possible
4. C_{VDD} is optional for added IC stability
5. Please refer to [Table 8: Current characteristics](#) for the maximum output load drive current capability

Figure 19. Typical application schematic for Data streaming mode

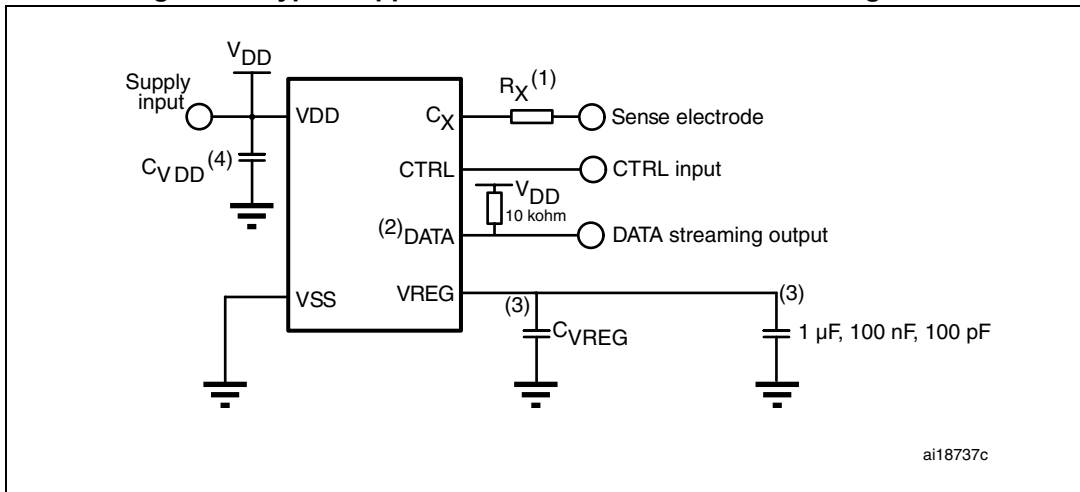

1. R_X is optional for added ESD protection
2. Open drain output pin
3. Keep track as short as possible
4. C_{VDD} is optional for added IC stability
5. Please refer to [Table 8: Current characteristics](#) for the maximum output load drive current capability

8 Design guidelines

8.1 Sensitivity adjustment

Several factors impact device sensitivity:

- The sensing electrode material and size
- The touch panel material and thickness
- The board layout and in particular the sensing signal tracks
- The ground coupling of the object (finger or hand) and sensor
- The touch or proximity detection threshold selected

8.1.1 PCB layout and construction

The PCB traces, wiring, and components associated or in contact with C_X pins become touch sensitive and should be treated with caution to limit the touch area to the desired location.

Even with AET it is important to limit the amount of stray capacitance on the C_X pin. This can be done by minimizing trace lengths and widths. To minimize cross-coupling, tracks from adjacent sensing channel should not run close to each other for long distances. For detailed information, refer to application note AN2869.

9 Electrical characteristics

9.1 Parameter conditions

Unless otherwise specified, all voltages are in reference to V_{SS} .

9.1.1 Minimum and maximum values

Unless otherwise specified, the minimum and maximum values are guaranteed in the worst conditions of ambient temperature and supply voltage by tests in production on 100% of the devices with an ambient temperature at $T_A = 25\text{ }^\circ\text{C}$.

Data based on characterization results, design simulation and/or technology characteristics are indicated in the table footnotes and are not tested in production.

9.1.2 Typical values

Unless otherwise specified, typical data are based on $T_A = 25\text{ }^\circ\text{C}$, and $V_{DD} = 5\text{ V}$. They are given only as design guidelines and are not tested.

9.1.3 Typical curves

Unless otherwise specified, all typical curves are given only as design guidelines and are not tested.

9.1.4 Loading capacitor

The loading conditions used for pin parameter measurement are shown in [Figure 20](#).

Figure 20. Pin loading conditions

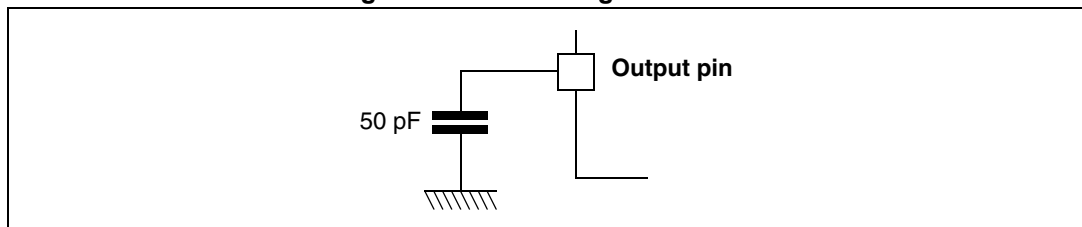

9.2 Absolute maximum ratings

Stresses above those listed as “absolute maximum ratings” may cause permanent damage to the device. This is a stress rating only and functional operation of the device under these conditions is not implied. Exposure to maximum rating conditions for extended periods may affect device reliability.

Table 7. Voltage characteristics

Symbol	Ratings	Maximum value	Unit
$V_{DD} - V_{SS}$	Supply voltage	6.8 ⁽¹⁾	V

1. Care must be taken as option bit could be modified if this voltage is higher than 5.5 V.

Table 8. Current characteristics

Symbol	Ratings	Maximum value	Unit
I_{VDD}	Total current into V_{DD} power lines (source) ⁽¹⁾	2	mA
I_{VSS}	Total current out of V_{SS} ground lines (sink) ⁽¹⁾	2	
I_{IO}	Output current sunk by output pin	1	
	Output current sourced by output pin	1	

1. All power (V_{DD}) and ground (V_{SS}) lines must always be connected to the external supply.

Table 9. Thermal characteristics

Symbol	Ratings	Value	Unit
T_{STG}	Storage temperature range	-65 to +150	°C
T_J	Junction temperature range (SO8 narrow and UDFPN8 package)	90	°C

9.3 Operating conditions

9.3.1 General operating conditions and supply characteristics

Table 10. Operating characteristics

Symbol	Parameter	Min.	Max.	Unit
V_{DD}	Supply voltage	2.3	5.5	V
T_A	Operating temperature	-40	+85	°C
t_{VDD}	Turn-on slope (rise time rate)	0	10	mS/V
	Turn-off slope (fall time rate)	0	10 ⁽¹⁾	

1. The supply voltage must reach 0 V when it drops below the minimum operating voltage.

9.3.2 Average current consumption

Test conditions: $T_A = 25\text{ }^\circ\text{C}$, $C_X = 20\text{ pF}$, and $R_X = 2\text{ k}\Omega$

Table 11. Average current consumption

Symbol	Parameter	Conditions	Typ.	Max.	Unit
I_{DD}	Normal power mode ⁽¹⁾	$3.05 \leq V_{DD} \leq 5.5$	60	75	μA
	Low power mode 1 ⁽²⁾		30	-	
	Low power mode 2 ⁽²⁾		17	-	
	Low power mode 3 ⁽²⁾		11	-	
	Control halt mode ⁽²⁾		2	7	
	Normal power mode ⁽¹⁾	$V_{DD} = 2.3\text{ V}$	45	60	
	Low power mode 1 ⁽²⁾		-	-	
	Low power mode 2 ⁽²⁾		-	-	
	Low power mode 3 ⁽²⁾		-	-	
	Control halt mode ⁽²⁾		2	7	

1. Tested in production.
2. Not applicable for Silicon revision 1, please refer to the STM8T143 errata sheet (STM8T143 device limitations).

Note: Consumption does not depend on detection thresholds.

9.3.3 I/O pin characteristics

Table 12. OUT/TOUT/DATA streaming pin characteristics

Symbol	Parameter	Conditions	Min ⁽¹⁾	Typ.	Max. ⁽¹⁾	Unit
V_{OH}	$V_{DD} = 5\text{ V}$	$I_{LOAD} = 1\text{ mA}$ $T_A = @ 25\text{ }^\circ\text{C}$	$V_{DD}-0.1$	$V_{DD}-0.1$	-	V
	$V_{DD} = 3.3\text{ V}$		$V_{DD}-0.1$	$V_{DD}-0.1$	-	
	$V_{DD} = 2.5\text{ V}$		$V_{DD}-0.2$	$V_{DD}-0.1$	-	
	$V_{DD} = 2.3\text{ V}$		$V_{DD}-0.2$	$V_{DD}-0.1$	-	
V_{OL}	$V_{DD} = 5\text{ V}$		-	0.06	0.07	
	$V_{DD} = 3.3\text{ V}$		-	0.06	0.08	
	$V_{DD} = 2.5\text{ V}$		-	0.06	0.08	
	$V_{DD} = 2.3\text{ V}$		-	0.07	0.09	
I_{Ikg}	Input leakage current ⁽²⁾		-1	-	1	μA

1. Guaranteed by characterization, not tested in production.
2. The maximum value may be exceeded if negative current is injected on adjacent pins.

Table 13. POUT/TOUT pin characteristics

Symbol	Parameter	Conditions	Min ⁽¹⁾	Typ.	Max. ⁽¹⁾	Unit
V _{OH}	V _{DD} = 5 V	I _{LOAD} = 1 mA T _A = @ 25 °C	V _{DD} -0.1	V _{DD} -0.1	-	V
	V _{DD} = 3.3 V		V _{DD} -0.1	V _{DD} -0.1	-	
	V _{DD} = 2.5 V		3.4	2.4	-	
	V _{DD} = 2.3 V		V _{DD} -0.1	V _{DD} -0.1	-	
V _{OL}	V _{DD} = 5 V		-	0.03	0.04	
	V _{DD} = 3.3 V		-	0.03	0.05	
	V _{DD} = 2.5 V		-	0.05	0.07	
	V _{DD} = 2.3 V		-	0.05	0.07	
I _{lkg}	Input leakage current ⁽²⁾	-	-1	-	1	μA

1. Guaranteed by characterization, not tested in production.
2. The maximum value may be exceeded if negative current is injected on adjacent pins.

Table 14. CTRL pin characteristics

Symbol	Parameter	Conditions	Min ⁽¹⁾	Max. ⁽¹⁾	Unit
V _{IL}	V _{DD} = 5 V	T _A = @ 25 °C	-	0.5	V
	V _{DD} = 3.3 V		-	0.3	
	V _{DD} = 2.5 V		-	0.25	
	V _{DD} = 2.3 V		-	0.2	
V _{IH}	V _{DD} = 5 V		4.5	-	
	V _{DD} = 3.3 V		3.0	-	
	V _{DD} = 2.5 V		2.25	-	
	V _{DD} = 2.3 V		1.8	-	
I _{lkg}	Input leakage current ⁽²⁾	-	-1	1	μA

1. Guaranteed by characterization, not tested in production.
2. The maximum value may be exceeded if negative current is injected on adjacent pins.

9.4 Regulator and reference voltage

Table 15. Regulator and reference voltage

Symbol	Parameter	Condition	Min.	Typ.	Max.	Unit
C_{ref}	Voltage regulator decoupling capacitance ⁽¹⁾	-	1	-	10	μF
V_{reg}	Regulated voltage during acquisition ⁽²⁾	$3.05 \leq V_{DD} \leq 5.5$	2.35	2.5	2.75	V
		$2.3 \leq V_{DD} \leq 2.65$	-	$V_{DD}-0.15$	-	

1. Equivalent serial $R_{resistor} \leq 0.2 \Omega$ at 1 MHz.
2. Operating above 3.05 V improves the device noise rejection. Between 2.65 V and 3.05 V the regulated voltage evolves gradually between $V_{DD} - 0.15$ V and the regulated voltage.

9.5 Capacitive sensing characteristics

The values in *Table 16: General capacitive sensing characteristics* are guaranteed by design. They include the oscillator tolerance, the t_{SAMPLING} period, and the debouncing influence.

Table 16. General capacitive sensing characteristics

Symbol	Parameter	Min	Typ	Max	Unit
f_{TRANSFER}	Charge-transfer frequency	200 ⁽¹⁾	250	300 ⁽¹⁾	kHz
t_{SAMPLING} ⁽²⁾	Normal power mode	7	9	11	ms
	Low power mode 1	21	27	33	
	Low power mode 2	80	100	120	
	Low power mode 3	240	300	360	
t_{AET}	Automatic electrode tuning process time ⁽³⁾	-	59	-	
t_{CTRL}	Acquisition halt or reference freeze control	40	-	-	
$t_{\text{recal_control}}$	CTRL pin pulse duration for recalibration	24	30	36	
Response time ⁽⁴⁾	Normal power mode	-	60	-	
	Low power mode 1	-	125	-	
	Low power mode 2	-	315	-	
	Low power mode 3	-	850	-	
$t_{\text{AET_HALT}}$	AET HALT period after end of detection	-	3	-	s
R_{FTh}	ECS filter freeze threshold in release state	-	Ref ±8	-	Burst count
T_{FTh}	ECS filter freeze threshold in touch state	-	Ref +16	-	
AET target value	AET target value	1344	1600	1856	
Gain	Gain target value A	-	200	-	
	Gain target value B	-	250	-	
	Gain target value C	-	300	-	
	Gain target value D	-	350	-	
	Gain target value E	-	400	-	
	Gain target value F	-	550	-	
	Gain target value G	-	700	-	
	Gain target value H	-	850	-	



Table 16. General capacitive sensing characteristics (continued)

Symbol	Parameter	Min	Typ	Max	Unit
t_{RECAL}	Time after recalibration before optimal device sensitivity (see Section 6: Device operation). Note: this value depends on the signal variation including noise level	-	354	-	$t_{SAMPLING}$
t_{SU}	Device startup time ⁽⁵⁾	-	51	-	
DDC	Detection debounce count (touch)	-	2	-	
	Detection debounce count (proximity)	-	6	-	
EDDC	End of detection debounce count (touch)	-	2	-	
	End of detection debounce count (proximity)	-	3	-	
V_{CXL}	Low state voltage value on C_X during burst	-	0.6	-	V
V_{trip}	Acquisition reference voltage	-	0.8	-	

1. Min and max values for $t_{TRANSFER}$ are given for a 3 V to 5.5 V operating range.
2. If Data streaming mode is activated, $t_{SAMPLING}$ is increased by the data frame period. Please refer to [Section 9.6: Streaming mode characteristics](#).
3. t_{AET} depends on the C_X capacitance value. This typical value is given for an electrode of 18 pF
4. Response time for detection depends on the event occurrence time during the acquisition period, the threshold settings, and the signal strength.
5. The device startup time is the time after power-up before any possible actuation.

Table 17. Internal C_S value

Internal sampling capacitor selection bits (ICS)			C_S capacitance value (nF)
ICS2 ⁽¹⁾	ICS1	ICS0	Typ
0	0	0	1.5
0	0	1	2
0	1	0	3
0	1	1	5
1	0	0	4.5
1	0	1	6
1	1	0	11
1	1	1	17.5

1. This bit is also used for EPCC selection. Please refer to [Table 18: Implemented EPCC values \(pF\)](#).

Table 18. Implemented EPCC values (pF)

General name	EPCC name	ICS bit 2	
		0	1
Implemented capacitance values	EPCC 0	0.3	0.6
	EPCC 1	0.6	1.2
	EPCC 2	1.2	2.4
	EPCC 3	2.4	4.8
	EPCC 4	4.8	9.6
	EPCC 5	9.6	19.2
Maximum PCC capacitance value		18.9	37.8

Table 19. External sensing component characteristics

Symbol	Parameter	Min.	Typ.	Max.	Unit
C_X	Equivalent electrode capacitance	1	-	60	pF
C_T	Equivalent touch capacitance	-	5	-	
R_X	Electrode serial resistance	-	2	22	kOhm

9.6 Streaming mode characteristics

Table 20. Data streaming timing characteristics

Symbol	Parameter	Typ.	Unit
t_{START}	DATA low time	17	μs
t_{BIT}	Data bit time	17	
t_{STOP}	DATA high time	29	

Figure 21. Data streaming timing diagram

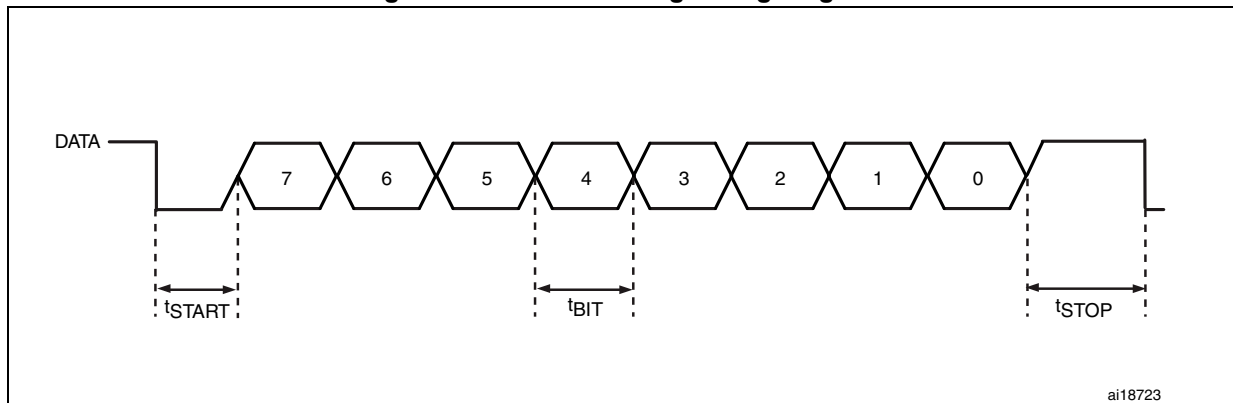

9.7 EMC characteristics

Susceptibility and emission tests are performed on a sample basis during product characterization.

Both the sample and its applicative hardware environment are mounted on a dedicated specific EMC board defined in the IEC61967-1 standard.

9.7.1 Functional EMS (electromagnetic susceptibility)

While running in the above described environment the product is stressed by two electromagnetic events until a failure occurs.

- **ESD:** Electrostatic discharge (positive and negative) is applied on all pins of the device until a functional disturbance occurs. This test complies with the IEC 1000-4-2 standard.
- **FTB:** A burst of fast transient voltage (positive and negative) is applied to V_{DD} and V_{SS} through a 100 pF capacitor, until a functional disturbance occurs. This test complies with the IEC 1000-4-4 standard.

A device reset allows normal operations to be resumed. The test results are given in [Table 21](#) based on the EMS levels and classes defined in application note AN1709.

9.7.2 Prequalification trials

Table 21. EMS data

Symbol	Parameter	Conditions	Level/class
V_{EFTB}	Fast transient voltage burst limits to be applied through 100pF on V_{DD} and V_{SS} pins to induce a functional disturbance	$V_{DD}= 5\text{ V}$, $T_A=+25\text{ °C}$, UFDFPN8 package, complies with IEC 1000-4-4	4A

9.7.3 Electromagnetic interference (EMI)

Emission tests conform to the IEC61967-2 standard for board layout and pin loading. Worse case EMI measurements are performed during maximum device activity.

Table 22. EMI data

Symbol	Parameter	General conditions	Monitored frequency band	$RC_{osc} = 1\text{ MHz}^{(1)}$	Unit
S_{EMI}	Peak level	$V_{DD}= 5\text{ V}$, $T_A= +25\text{ °C}$, UFDFPN8 package, Complies with SAE J1752/3, No finger on touch electrode	0.1 MHz to 30 MHz	-4	dB μ V
			30 MHz to 130 MHz	-3	
			130 MHz to 1 GHz	-4	
	-		1		
	SAE EMI level				

1. Data based on characterization results, not tested in production.

9.7.4 Absolute maximum ratings (electrical sensitivity)

Based on two different tests (ESD and LU) using specific measurement methods, the product is stressed in order to determine its performance in terms of electrical sensitivity. For more details, refer to the application note AN1181.

9.7.5 Electrostatic discharge (ESD)

Electrostatic discharges (3 positive then 3 negative pulses separated by 1 second) are applied to the pins of each sample according to each pin combination. The sample size depends on the number of supply pins in the device (3 parts*(n+1) supply pin). This test conforms to the JESD22-A114A/A115A standard. For more details, refer to the application note AN1181.

Table 23. ESD absolute maximum ratings

Symbol	Ratings	Conditions	Class	Maximum value ⁽¹⁾	Unit
V _{ESD(HBM)}	Electrostatic discharge voltage (Human body model)	T _A = +25°C, conforming to JESD22-A114	3A	4	kV
V _{ESD(CDM)}	Electrostatic discharge voltage (Charge device model)	T _A = +25°C, conforming to JESD22-C101	IV	1	

1. Data based on characterization results, not tested in production

9.7.6 Static latchup

Two complementary static tests are required on 10 parts to assess the latchup performance.

- A supply overvoltage (applied to each power supply pin) and
- A current injection (applied to each input, output and configurable I/O pin) are performed on each sample.

This test conforms to the EIA/JESD 78 IC latchup standard. For more details, refer to application note AN1181.

Table 24. Electrical sensitivities

Symbol	Parameter	Conditions	Class ⁽¹⁾
LU	Static latchup	T _A = +25 °C	A
		T _A = +85 °C	

1. Class description: A class is an STMicroelectronics internal specification. All its limits are higher than the JEDEC specifications, that means when a device belongs to class A it exceeds the JEDEC standard. Class B strictly covers all the JEDEC criteria (international standard).

10 Package characteristics

In order to meet environmental requirements, ST offers these devices in different grades of ECOPACK® packages, depending on their level of environmental compliance. ECOPACK® specifications, grade definitions and product status are available at www.st.com.

ECOPACK® is an ST trademark.

10.1 Package mechanical data

10.1.1 SO8 package mechanical data

Figure 22. SO8-lead plastic small outline - package outline

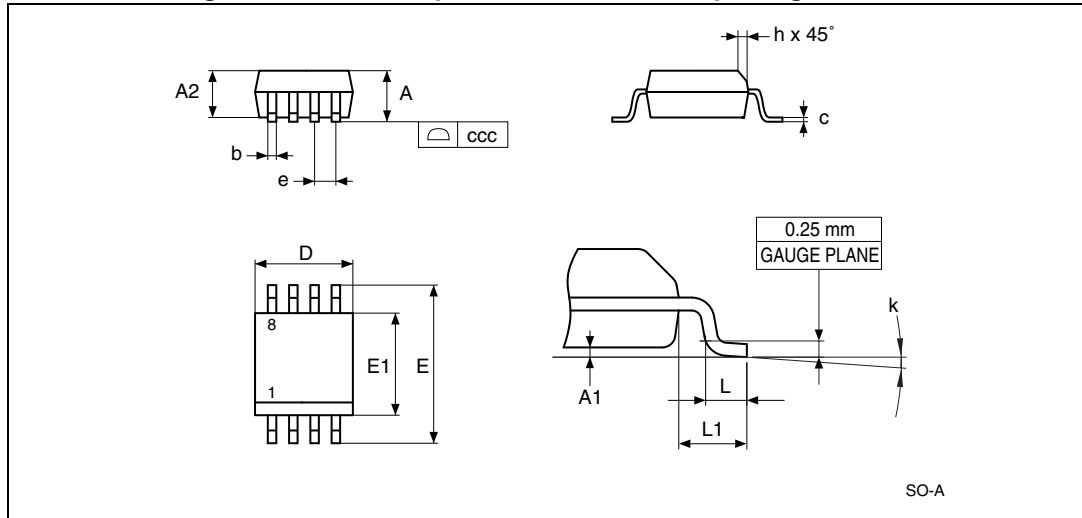
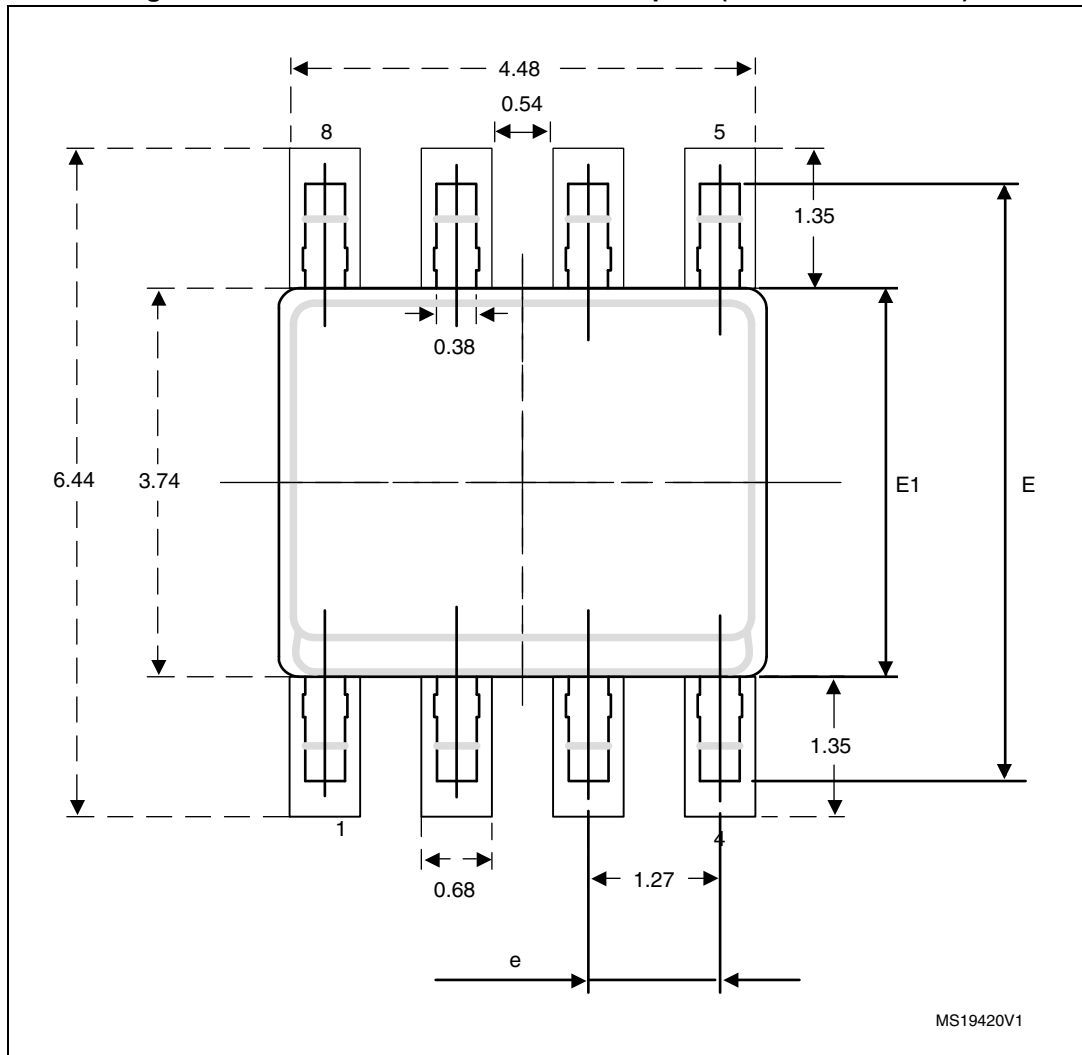

Table 25. SO8-lead plastic small outline - package mechanical data

Symbol	millimeters			inches ⁽¹⁾		
	Min	Typ	Max	Min	Typ	Max
A	-	-	1.750	-	-	0.0689
A1	0.100	-	0.250	0.0039	-	0.0098
A2	1.250	-	-	0.0492	-	-
b	0.280	-	0.480	0.0110	-	0.0189
c	0.170	-	0.230	0.0067	-	0.0091
ccc	-	-	0.100	-	-	0.0039
D ⁽²⁾	4.800	4.900	5.000	0.1890	0.1929	0.1969
E	5.800	6.000	6.200	0.2283	0.2362	0.2441
E1 ⁽³⁾	3.800	3.900	4.000	0.1496	0.1535	0.1575
e	-	1.270	-	-	0.0500	-
h	0.250	-	0.500	0.0098	-	0.0197
k	0°	-	8°	0°	-	8°
L	0.400	-	1.270	0.0157	-	0.0500
L1	-	1.040	-	-	0.0409	-

1. Values in inches are rounded to 4 decimal digits
2. Dimension D does not include mold flash, protrusions or gate burrs. Mold flash, protrusions or gate burrs should not exceed 0.15mm in total (both side).
3. Dimension E1 does not include interlead flash or protrusions. Interlead flash or protrusions should not exceed 0.25 mm per side.

Figure 23. SO8 narrow recommended footprint (dimensions in mm)



1. Drawing is not to scale.

10.1.2 UFDFPN8 package mechanical data

Figure 24. UFDFPN8-lead ultra thin fine pitch dual flat package (MLP) package outline

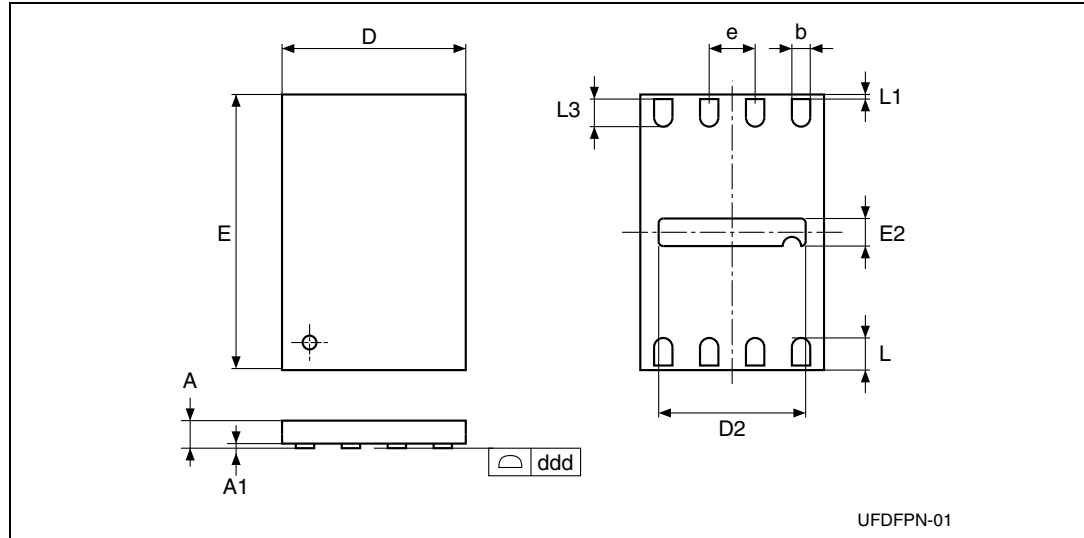
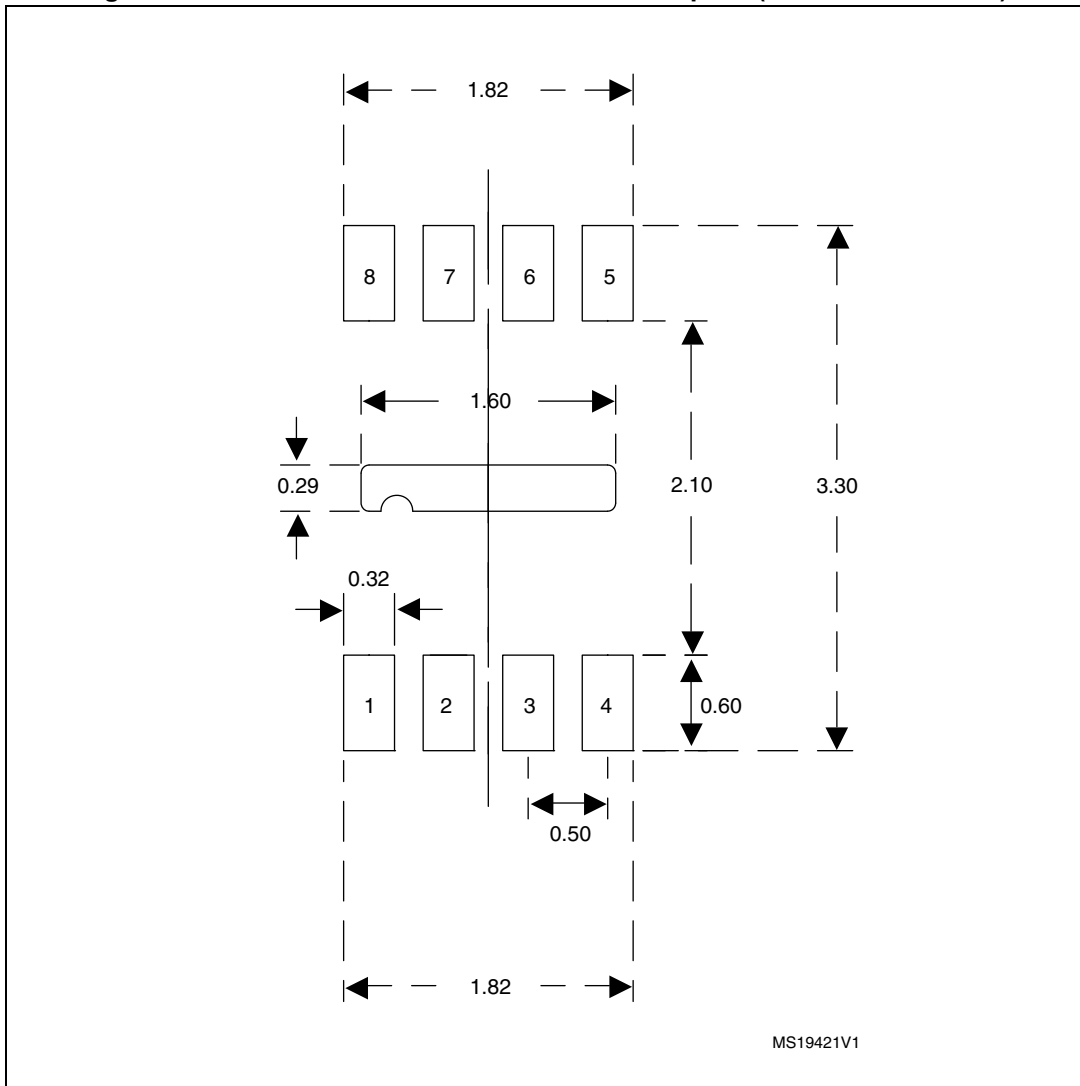

Table 26. UFDFPN8-lead ultra thin fine pitch dual flat - package mechanical data

Symbol	millimeters			inches ⁽¹⁾		
	Min	Typ	Max	Min	Typ	Max
A ⁽²⁾	0.450	0.550	0.600	0.0177	0.0217	0.0236
A1	0.000	0.020	0.050	0.0000	0.0008	0.0020
b	0.200	0.250	0.300	0.0079	0.0098	0.0118
D	1.900	2.000	2.100	0.0748	0.0787	0.0827
D2	1.500	1.600	1.700	0.0591	0.0630	0.0669
E	2.900	3.000	3.100	0.1142	0.1181	0.1220
E2	0.100	0.200	0.300	0.0039	0.0079	0.0118
e	-	0.500	-	-	0.0197	-
L	0.400	0.450	0.500	0.0157	0.0177	0.0197
L1	-	-	0.150	-	-	0.0059
L3	0.300	-	-	0.0118	-	-
Tolerance	millimeters			inches		
ddd ⁽³⁾	-	0.080	-	-	0.0031	-

1. Values in inches are rounded to 4 decimal digits
2. In order to prevent undesired effects such as spurious detections or modified sensitivity the UFDFPN8 package should not be directly exposed to light sources (visible or invisible).
3. Applied for exposed die paddle and terminals. Exclude embedding part of exposed die paddle from measuring.

Figure 25. UFDFPN 2 x 3 mm recommended footprint (dimensions in mm)



1. Drawing is not to scale.

10.2 Package thermal characteristics

The maximum chip junction temperature (T_{Jmax}) must never exceed the values given in [Table 10: Operating characteristics on page 38](#).

The maximum chip-junction temperature, T_{Jmax} , in degrees Celsius, may be calculated using the following equation:

$$T_{Jmax} = T_{Amax} + (P_{Dmax} \times \Theta_{JA})$$

Where:

- T_{Amax} is the maximum ambient temperature in °C
- Θ_{JA} is the package junction-to-ambient thermal resistance in °C/W
- P_{Dmax} is the sum of P_{INTmax} and $P_{I/Omax}$ ($P_{Dmax} = P_{INTmax} + P_{I/Omax}$)
- P_{INTmax} is the product of I_{DD} and V_{DD} , expressed in Watts. This is the maximum chip internal power.
- $P_{I/Omax}$ represents the maximum power dissipation on output pins

Where:

$$P_{I/Omax} = \Sigma (V_{OL} * I_{OL}) + \Sigma ((V_{DD} - V_{OH}) * I_{OH}),$$

taking into account the actual V_{OL}/I_{OL} and V_{OH}/I_{OH} of the I/Os at low and high level in the application.

Table 27. Thermal characteristics

Symbol	Parameter	Value	Unit
Θ_{JA}	Thermal resistance junction-ambient SO8 (narrow)	130	°C/W
Θ_{JA}	Thermal resistance junction-ambient UFDFPN 8 (2 x 3 mm)	120	°C/W

Note: Thermal resistances are based on JEDEC JESD51-2 with 4-layer PCB in a natural convection environment.

10.2.1 Reference document

JESD51-2 integrated circuits thermal test method environment conditions - natural convection (still air). Available from www.jedec.org.

11 Ordering information

11.1 STM8T143 ordering information scheme

Figure 26. STM8T143 ordering information scheme

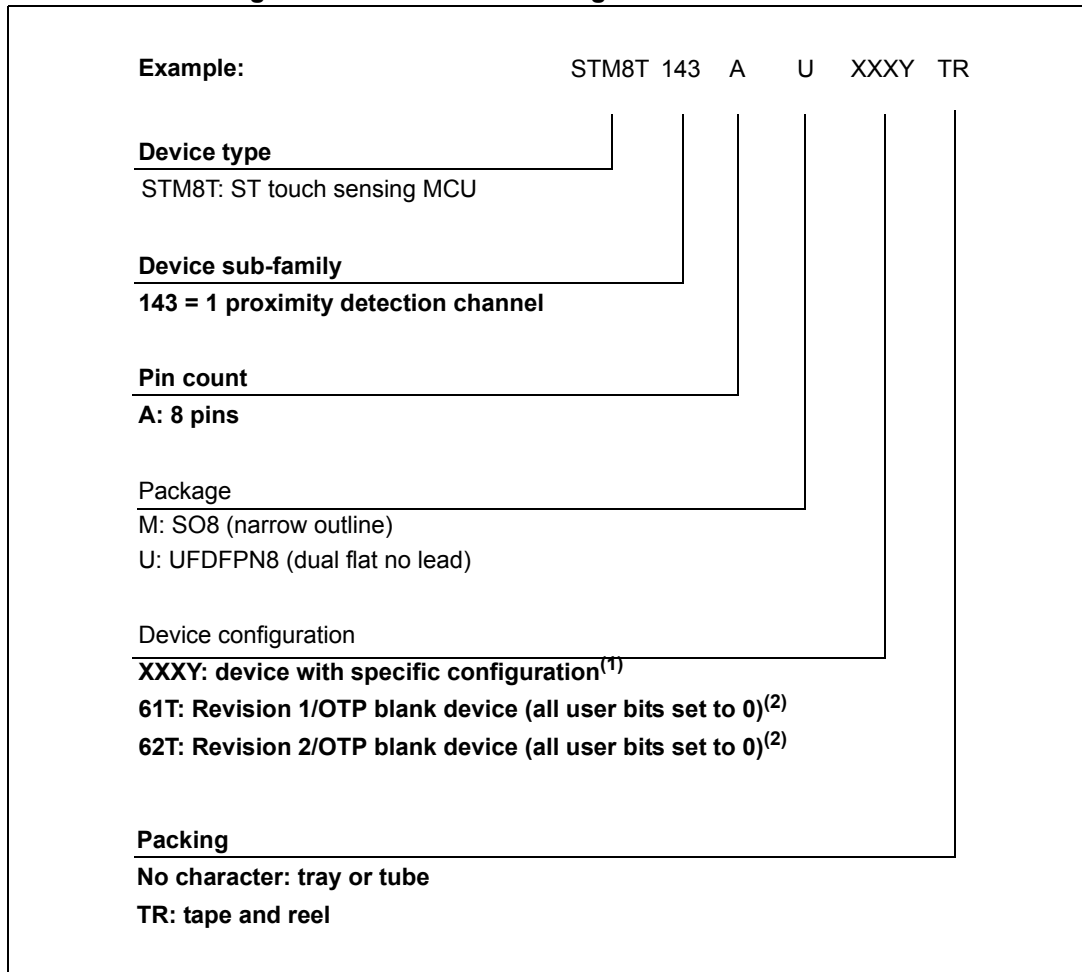

1. See explanation below of "in factory option byte programming service"
2. The STM8T143 OTP devices are available for development and production. These parts are blank devices with unconfigured option bytes (all option bits are set to '0').

11.2 Orderable favorite device lists

The STM8T143 OTP devices listed below are available for development and production. These parts are blank devices or configured with a specific configuration. See [Table 28](#). Contact STMicroelectronics sales office for availability.

11.2.1 Part number option bytes

Table 28. Option byte values

Part number	OPT0	OPT1	OPT2
STM8T143AM61T	0x00	0x00	0x00
STM8T143AM62T	0x00	0x00	0x00
STM8T143AUTAB2TR	0xC8	0x00	0x10
STM8T143AUMEI2TR	0xF0	0x00	0x00
STM8T143AULET2TR	0xE0	0x01	0x10

11.3 In-factory option byte programming service

For specific configurations, in-factory option byte programming is available on customer request and for large order quantities. Customers have to fill out the option list (see below) and send it back to STMicroelectronics. Customers are then informed by STMicroelectronics about the ordering part number corresponding to the customer configuration. The XXXY digits of the final ordering part number (e.g. STM8T143AUXXXY) depends on the device configuration and firmware revision number and is assigned by STMicroelectronics.

11.4 Revision code on device markings

Table 29, Figure 27 and Figure 28 show the part numbers and standard marking composition for the UDFFPN8 and SO8 packages respectively.

Table 29. Device identification

Rev no.	Part no. SO8 package	Part no. UDFFPN8 package	Marking SO8 package ⁽¹⁾	Marking UDFFPN8 package ⁽²⁾
1	STM8T143AM61T	STM8T143AU61T	8T143A61	T143
2	STM8T143AM62T	STM8T143AU62T	T143AM62	1432
3	N/A	STM8T143AUTAB2TR	N/A	TAB
4	N/A	STM8T143AUMEI2TR	N/A	MEI
5	N/A	STM8T143AULET2TR	N/A	LET

1. See [Figure 27: SO8 package marking](#).
2. See [Figure 28: UDFFPN8 package marking](#).

Figure 27. SO8 package marking

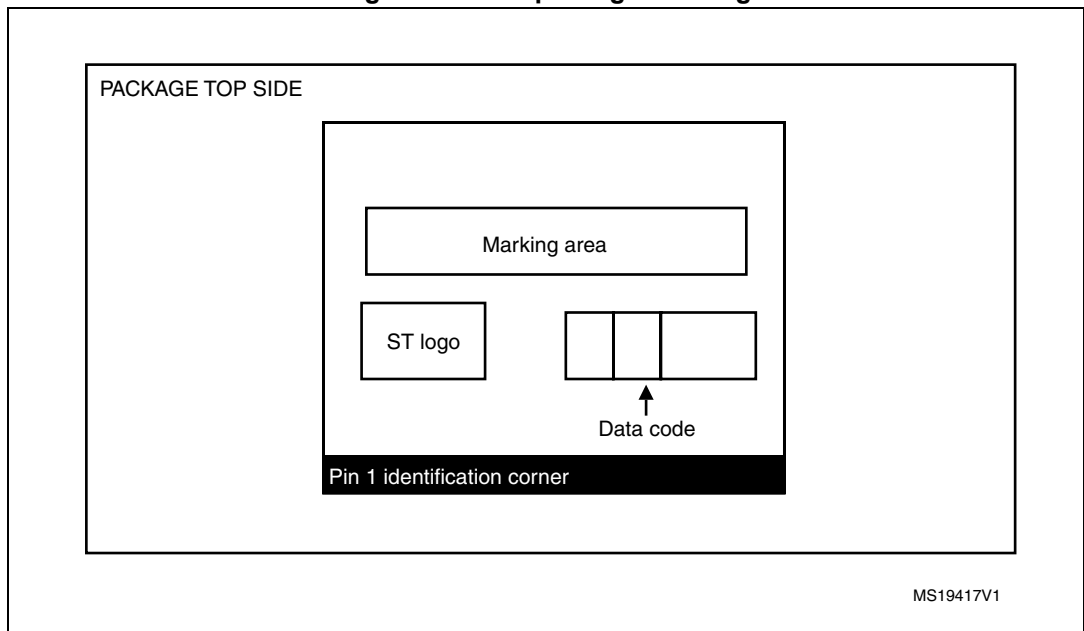
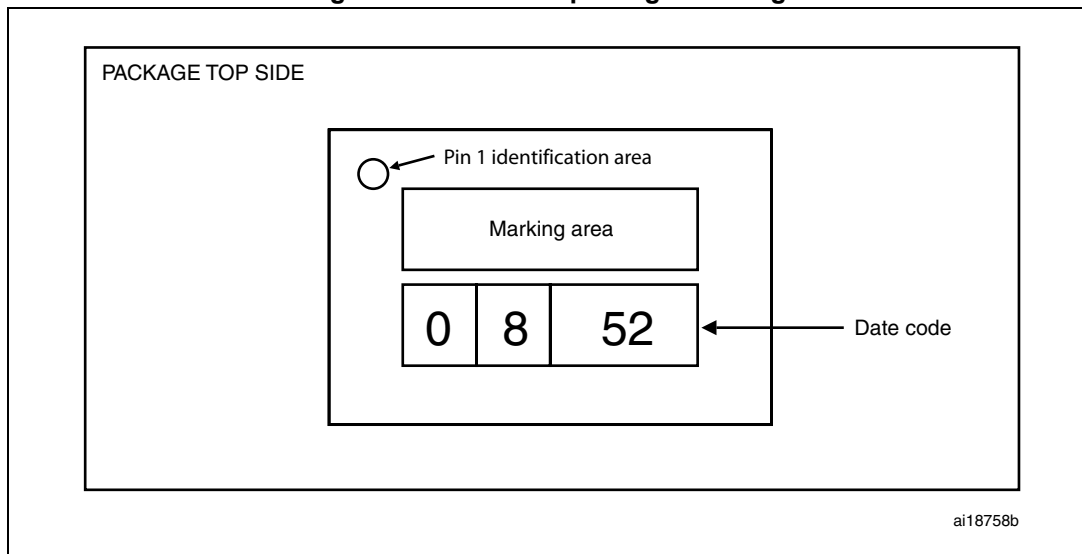

Figure 28. UDFPN8 package marking



STM8T143 programming service option list Rev 7 (last update: January 2014)

Customer name:

Address:

Contact name:

Phone number

Customer settings (tick one box by option)

Package type:

- DFN8: STM8T143AU
 SO8: STM8T143AM(1)

Output type (used only in CTRL mode – see [Section 6.2.2: Control mode](#))

- Proximity output⁽²⁾
 Touch output

Release threshold ratio (see [Section 5.3: Detection and release thresholds](#))

- 75 %⁽²⁾
 87.5 %

Gain target

- Gain target value A (200)⁽²⁾
 Gain target value B (250)
 Gain target value C (300)
 Gain target value D (350)
 Gain target value E (400)
 Gain target value F (550)
 Gain target value G (700)
 Gain target value H (850)

Data streaming mode (see [Section 6.2.3: Data streaming mode](#))

- Disabled⁽²⁾
 Enabled

Low power mode (see [Section 6.4: Power modes](#) and [Table 16: General capacitive sensing characteristics](#))

- Normal power mode⁽²⁾
 Low power mode 1
 Low power mode 2
 Low power mode 3

Reference freeze timeout t_{RFT} (see [Section 5.5.3: Reference freeze and reference freeze timeout](#))

- Infinite⁽²⁾
 18 s
 60 s
 3 s

Dynamic calibration delay t_{DYCAL} (see [Section 5.4: Dynamic calibration \(DYCAL\)](#))

- 250 ms⁽²⁾
 1 s

STM8T143 programming service option list Rev 7 (last update: January 2014)

Customer name:

Address:

Contact name:

Phone number

Customer settings (tick one box by option)

Dual/Control mode (see [Section 6.2.1: Dual output mode](#) and [Section 6.2.2: Control mode](#))

- Pin 8 in control input⁽²⁾
- Pin 8 in proximity output mode

Touch detection threshold (see [Section 5.3: Detection and release thresholds](#))

- Touch detection (TTh) threshold value 40⁽²⁾
- Touch detection (TTh) threshold value 60
- Touch detection (TTh) threshold value 100
- Touch detection (TTh) threshold value 200
- Touch detection (TTh) threshold value 340
- Touch detection (TTh) threshold value 500
- Touch detection (TTh) threshold value 700
- Touch detection (TTh) threshold value 900

Proximity detection threshold (see [Section 5.3: Detection and release thresholds](#))

- Proximity detection (PTh) threshold value 4⁽²⁾
- Proximity detection (PTh) threshold value 8
- Proximity detection (PTh) threshold value 16
- Proximity detection (PTh) threshold value 32

Output polarity (see [Section 6.3: Output polarity](#))⁽³⁾

- Active low⁽²⁾
- Active high

Control type (see [Section 6.2.2: Control mode](#))

- Halts conversion control⁽²⁾
- Reference freeze control

Packaging

- Tape and reel
- Tray or tube

- (1) Fastrom is not available in SO8 device.
- (2) Configuration by default in OTP devices.
- (3) Effective only when data streaming mode is disabled

Comment:

Signature:

Date:

12 STM8T143 programming tool

Figure 29 shows the STM8T143 programming tool.

To program the device option bytes the following materials are available:

- Programming socket board (STM8T14X-SB). When connected to the programming dongle, this board allows the programming of SO8 or UDFPN8 devices.
- A programming dongle (ST-TSLINK) and its associated programming software, STVP.

Figure 29. STM8T143 programming tool



Table 30. Ordering information

Part number	Order codes	Description
ST-TSLINK	ST-TSLINK	STM8T143 programming dongle
STM8T14X-SB	STM8T14X-SB	STM8T143 socket board

13 Revision history

Table 31. Document revision history

Date	Revision	Changes
17-May-2011	1	Initial release
31-Aug-2011	2	<p><i>Features</i>: updated bullet about low power management.</p> <p><i>Block diagram</i>: updated <i>Figure 1: STM8T143 block diagram</i>, removed <i>Power-on-reset (POR)</i>, and updated <i>Advanced ProxSense engine</i>.</p> <p><i>Section 4.3: Internal sampling capacitor</i>: added 'to fit a wide range of applications'.</p> <p><i>Section 5: STM8T143 processing</i>: realigned bullet points according to order of subsections.</p> <p><i>Section 5.2: Signal calculation and reference calibration</i>: updated</p> <p><i>Section 5.3: Detection and release thresholds</i>: updated</p> <p><i>Figure 7: Automatic electrode tuning (AET)</i>: replaced</p> <p><i>Figure 8: Signal reference and detection threshold (not detailed)</i>: replaced.</p> <p><i>Figure 9: DYCAL general operation</i>: replaced</p> <p><i>Figure 10: DYCAL operation with water residue</i>: replaced</p> <p><i>Figure 11: No DYCAL</i>: updated</p> <p>Added <i>Figure 12: IIR filter formula</i></p> <p><i>Section 5.5.2: ECS halt</i>: in <i>Figure 14: Unwanted detection managed by the reference freeze timeout</i>: replaced 'reference - D_{Th}' with 'Reference - PTh'; added note 5.5.4.</p> <p><i>Section 5.4: Dynamic calibration (DYCAL)</i>: updated</p> <p>Added <i>Section 5.5.4: ECS filter constant adjustment</i> and <i>Figure 15: ECS filter K constant management</i>.</p> <p>Removed <i>Reference freeze timeout</i> figure</p> <p><i>Section 5.7: Host control input</i>: updated</p> <p><i>Table 3: Option byte description</i>: updated OPT2 (bit 4), OPT0 (bits [7:5] and [4:3]).</p> <p><i>Table 6: Data streaming frame</i>: updated description of bit 47 (byte 5).</p> <p><i>Table 8: Current characteristics</i>: updated I_{VDD}, I_{VSS}, and I_{IO} max values.</p> <p><i>Table 11: Average current consumption</i>: updated all typ and max values; updated footnotes.</p> <p><i>Table 12: OUT/TOUT/DATA streaming pin characteristics</i>: replaced all TBDs with values; added condition 25 °C; added footnote 1.</p> <p><i>Table 13: POUT/TOUT pin characteristics</i>: replaced all TBDs with values; added condition 25 °C; added footnote 1.</p> <p><i>Table 14: CTRL pin characteristics</i>: replaced all TBDs with values; added condition 25 °C; added footnote 1.</p>

Table 31. Document revision history (continued)

Date	Revision	Changes
31-Aug-2011	2 cont'd	<p><i>Table 16: General capacitive sensing characteristics</i>: updated f_{TRANSFER}, response time, and device startup time parameters; added min and max values for t_{SAMPLING} and AET target value parameter; added footnotes 1. and 5.; updated footnote 4.</p> <p><i>Table 17: Internal CS value</i>: added ICS bit values.</p> <p><i>Table 18: Implemented EPCC values (pF)</i>: added EPCC6 and capacitance bit 6 values.</p> <p><i>Table 21: EMS data</i>: removed V_{FESD} parameter and added level/class for V_{EFTB} parameter.</p> <p><i>Table 22: EMI data</i>: added values for $RC_{\text{OSC}} = 1$ MHz.</p> <p><i>Table 23: ESD absolute maximum ratings</i>: updated class, max value and unit.</p> <p><i>Table 24: Electrical sensitivities</i>: added class value.</p> <p><i>Table 26: UFDFPN8-lead ultra thin fine pitch dual flat - package mechanical data</i>: added footnote 2.</p> <p>Updated programming service option list.</p>
15-Nov-2011	3	<p>Added SO8 package and updated all information relating to this package throughout document.</p> <p><i>Figure 3: UFDFPN8 pinout</i>: updated pins 1 and 8.</p> <p><i>Table 1: STM8T143 pin descriptions</i>: updated layout and content.</p> <p><i>Figure 5: STM8T143 measuring circuitry</i>: changed "STM8T143" to "Device".</p> <p><i>Section 4.4: Electrode parasitic capacitance compensation (EPCC)</i>: removed text concerning EPCC hardware and fixed compensation capacitance.</p> <p><i>Section 5: STM8T143 processing</i>: updated title; updated second bullet point to "signal and reference calibration".</p> <p><i>Section 5.1: Automatic electrode tuning (AET)</i>: text updated to improve technical clarity and readability, values replaced; updated and improved appearance of <i>Figure 7: Automatic electrode tuning (AET)</i>.</p> <p><i>Section 5.2: Signal calculation and reference calibration</i>: removed bullet points regarding AET; small text changes.</p> <p><i>Section 5.3: Detection and release thresholds</i>: small text changes, corrections and clarifications; updated title, improved appearance, and removed 't_{DYCAL}' from <i>Figure 8: Signal reference and detection threshold (not detailed)</i>.</p> <p><i>Section 5.4: Dynamic calibration (DYCAL)</i>: small text changes and corrections; updated titles and content of <i>Figure 9: DYCAL general operation</i> and <i>Figure 10: DYCAL operation with water residue</i>; improved appearance of all figures in this section.</p> <p><i>Section 5.5.2: ECS halt</i>: updated appearance of <i>Figure 13: ECS halt</i> and removed note 2 underneath it.</p> <p><i>Section 5.5.3: Reference freeze and reference freeze timeout</i>: moved section to current location; updated title and improved appearance of <i>Figure 14: Unwanted detection managed by the reference freeze timeout</i>.</p>

Table 31. Document revision history (continued)

Date	Revision	Changes
15-Nov-2011	3 cont'd	<p><i>Section 5.5.4: ECS filter constant adjustment</i>: updated title and added reference to <i>Figure 15: ECS filter K constant management</i>.</p> <p><i>Section 5.6: Debounce filter</i>: removed last sentence of this section which concerned the HALT function.</p> <p><i>Section 5.7: Host control input</i> and <i>Section 5.7.1: CTRL pin management</i>: removed.</p> <p><i>Section 6: Device operation</i>: updated bullet points concerning Control, Dual output, and Data streaming modes.</p> <p><i>Table 2: Option bytes</i>: updated abbreviations for touch and proximity detection thresholds.</p> <p><i>Table 3: Option byte description</i>: small corrections to bit 5 (OPT2), bit 0 (OPT 1) and bit 0 (OPT 0); added gain target values (instead of A, B, C etc.) for bits [3:1] of OPT 2.</p> <p><i>Section 6.2.1: Dual output mode</i>: renamed section; added <i>Table 4: Pin 1 configuration</i> and <i>Table 5: Pin 8 configuration</i>.</p> <p><i>Section 6.2.2: Control mode</i>: small text changes and corrections; added final explanatory sentence to <i>Reference freeze control mode</i>.</p> <p><i>Section 6.2.3: Data streaming mode</i>: small text changes and corrections; updated bits 34, 47, 46, and 45 of <i>Table 6: Data streaming frame</i>.</p> <p><i>Section 6.4: Power modes</i>: moved to the end of <i>Section 6</i>.</p> <p><i>Section 7: Typical application diagram</i>: moved after <i>Section 6: Device operation</i>.</p> <p><i>Figure 17: Typical application schematic for Control mode</i>: renamed figured and updated content and footnotes.</p> <p><i>Figure 18: Typical application schematic for Dual output mode</i>: renamed figured and updated content and footnotes.</p> <p><i>Figure 19: Typical application schematic for Data streaming mode</i>: renamed figured and updated content and footnotes.</p> <p><i>Table 7: Voltage characteristics</i>: updated max value of supply voltage parameter and added footnote 1.</p> <p><i>Table 11: Average current consumption</i>: updated with new typ and max values; updated first condition; replaced "Conversion" with "Control"; updated footnote 2.</p> <p><i>Table 12: OUT/TOUT/DATA streaming pin characteristics</i>: removed footnote 1. from "Typ" column.</p> <p><i>Table 13: POUT/TOUT pin characteristics</i>: added "TOUT" to table title; removed footnote 1. from "Typ" column.</p> <p><i>Table 15: Regulator and reference voltage</i>: updated first condition.</p> <p><i>Section 9.5: Capacitive sensing characteristics</i>: removed "Test conditions: T_A = 25 °C"; placed note at the end of this table at the beginning.</p> <p><i>Table 16: General capacitive sensing characteristics</i>: added typ value for parameter "CTRL pin pulse duration for recalibration"; added typ values for parameters "Low power modes 1, 2, and 3" and removed footnote associated with them; replaced "release" with "touch" in the parameter "ECS filter freeze threshold in touch state"; small corrections to footnotes 3. and 4.</p> <p><i>Table 17: Internal CS value</i>: added typ value to "C_S capacitance value (nF) parameter; added footnote 1.</p>



Table 31. Document revision history (continued)

Date	Revision	Changes
15-Nov-2011	3 cont'd	<p><i>Table 18: Implemented EPCC values (pF)</i>: updated title; replaced name of bit; removed EPCC 6 data, updated “Maximum PCC capacitance value”; added footnote 1.</p> <p><i>Figure 23: SO8 narrow recommended footprint (dimensions in mm)</i>: added.</p> <p><i>Figure 25: UFDFPN 2 x 3 mm recommended footprint (dimensions in mm)</i>: added.</p> <p><i>Figure 26: STM8T143 ordering information scheme</i>: updated package and device configuration information; updated footnote 2.</p> <p><i>Section 11.2: Orderable favorite device lists</i>: updated rev 1 UFDFPN8 OTP device and added rev 2 UFDFPN8 OTP device.</p> <p><i>Figure 27: SO8 package marking</i>: added.</p> <p><i>Figure 28: UFDFPN8 package marking</i>: added.</p> <p>Updated programming service option list.</p> <p><i>Section 12: STM8T143 programming tool</i>: updated first bullet point and replaced <i>Figure 29: STM8T143 programming tool</i>.</p>
12-Sep-2012	4	<p>Updated all information relating to Control mode.</p> <p><i>Figure 2: SO8 pinout</i>, <i>Figure 3: UFDFPN8 pinout</i> and <i>Table 1: STM8T143 pin descriptions</i>: Updated Pin 1 name to “OUT”.</p> <p><i>Table 10: Operating characteristics</i>: Updated Min. value of V_{DD}.</p> <p><i>Table 11: Average current consumption</i>: Updated V_{DD} conditions.</p> <p><i>Table 12: OUT/TOUT/DATA streaming pin characteristics</i> and <i>Table 13: POUT/TOUT pin characteristics</i>: Updated Min. and Typ. values of V_{OH}. Updated list of V_{DD} parameter. Added I_{IKG} parameter.</p> <p><i>Table 14: CTRL pin characteristics</i>: Updated list of V_{DD} parameter. Added I_{IKG} parameter.</p> <p><i>Table 15: Regulator and reference voltage</i>: Added note 2. Updated V_{reg} conditions, Min. and Max. values.</p> <p><i>Table 16: General capacitive sensing characteristics</i>: Updated Min. and Max. values. Added V_{trip} parameter.</p> <p><i>Table 18: Implemented EPCC values (pF)</i>: Moved note 1. on ICS bit 2 definition.</p> <p>Updated programming service option list.</p> <p><i>Section 12: STM8T143 programming tool</i>: updated part number of Programming socket board.</p>

Table 31. Document revision history (continued)

Date	Revision	Changes
17-Apr-2013	5	<p>Updated Table 7: Voltage characteristics.</p> <p>Replaced any occurrence of t_{DYCAL_T} by t_{DYCAL}.</p> <p>In Table 2: Option bytes, replaced:</p> <ul style="list-style-type: none"> – "tDYCAL" by "Dynamic calibration delay" – "Touch detection threshold (TTh)" by "Touch detection threshold" – "Proximity detection threshold (PTh)" by "Proximity detection threshold" <p>In Table 3: Option byte description</p> <ul style="list-style-type: none"> – replaced the release threshold ratio of 90% by 87.5%. – renamed "Reference freeze timeout" by "Reference freeze timeout (tRFT) " – updated the value information for the Reference freeze timeout – renamed "tDYCAL" by "Dynamic calibration delay (tDYCAL)" – updated the value information for the Dynamic calibration delay <p>Removed tRFT and tDYCAL rows in Table 16: General capacitive sensing characteristics</p> <p>Updated the "programming service option list" form in Section 11.4: Revision code on device markings</p> <p>Changed "Touch output" signal rising edge position in Figure 9: DYCAL general operation and Figure 10: DYCAL operation with water residue</p>
18-Oct-2013	6	<p>Modified note 2 below Table 15: Regulator and reference voltage on page 41.</p> <p>Removed note 1 in Table 18: Implemented EPCC values (pF) on page 44.</p> <p>Updated Section 11.2: Orderable favorite device lists on page 54</p> <p>Added Section 11.4: Revision code on device markings on page 55.</p> <p>Moved Section 11.4: Revision code on device markings on page 55 to Section 11.2.1: Part number option bytes on page 54</p> <p>Added last two rows in Table 29: Device identification on page 55.</p> <p>Updated the "programming service option list" form in Section 11.4: Revision code on device markings on page 55.</p> <p>Added first row in Section : Customer settings (tick one box by option) on page 57 and insert note.</p> <p>Added note in Section : <input type="checkbox"/> Proximity output(2) on page 57</p> <p>Updated Disclaimer content to Rev5-4</p> <p>Updated Section : (1) Fastrom is not available in SO8 device. on page 58</p> <p>Added new code Fastrom in Table 28: Option byte values on page 54 and Table 29: Device identification on page 55</p>
27-Jan-2014	7	<p>Changed operating supply voltage range in Section : Features.</p>

Please Read Carefully:

Information in this document is provided solely in connection with ST products. STMicroelectronics NV and its subsidiaries ("ST") reserve the right to make changes, corrections, modifications or improvements, to this document, and the products and services described herein at any time, without notice.

All ST products are sold pursuant to ST's terms and conditions of sale.

Purchasers are solely responsible for the choice, selection and use of the ST products and services described herein, and ST assumes no liability whatsoever relating to the choice, selection or use of the ST products and services described herein.

No license, express or implied, by estoppel or otherwise, to any intellectual property rights is granted under this document. If any part of this document refers to any third party products or services it shall not be deemed a license grant by ST for the use of such third party products or services, or any intellectual property contained therein or considered as a warranty covering the use in any manner whatsoever of such third party products or services or any intellectual property contained therein.

UNLESS OTHERWISE SET FORTH IN ST'S TERMS AND CONDITIONS OF SALE ST DISCLAIMS ANY EXPRESS OR IMPLIED WARRANTY WITH RESPECT TO THE USE AND/OR SALE OF ST PRODUCTS INCLUDING WITHOUT LIMITATION IMPLIED WARRANTIES OF MERCHANTABILITY, FITNESS FOR A PARTICULAR PURPOSE (AND THEIR EQUIVALENTS UNDER THE LAWS OF ANY JURISDICTION), OR INFRINGEMENT OF ANY PATENT, COPYRIGHT OR OTHER INTELLECTUAL PROPERTY RIGHT.

ST PRODUCTS ARE NOT DESIGNED OR AUTHORIZED FOR USE IN: (A) SAFETY CRITICAL APPLICATIONS SUCH AS LIFE SUPPORTING, ACTIVE IMPLANTED DEVICES OR SYSTEMS WITH PRODUCT FUNCTIONAL SAFETY REQUIREMENTS; (B) AERONAUTIC APPLICATIONS; (C) AUTOMOTIVE APPLICATIONS OR ENVIRONMENTS, AND/OR (D) AEROSPACE APPLICATIONS OR ENVIRONMENTS. WHERE ST PRODUCTS ARE NOT DESIGNED FOR SUCH USE, THE PURCHASER SHALL USE PRODUCTS AT PURCHASER'S SOLE RISK, EVEN IF ST HAS BEEN INFORMED IN WRITING OF SUCH USAGE, UNLESS A PRODUCT IS EXPRESSLY DESIGNATED BY ST AS BEING INTENDED FOR "AUTOMOTIVE, AUTOMOTIVE SAFETY OR MEDICAL" INDUSTRY DOMAINS ACCORDING TO ST PRODUCT DESIGN SPECIFICATIONS. PRODUCTS FORMALLY ESCC, QML OR JAN QUALIFIED ARE DEEMED SUITABLE FOR USE IN AEROSPACE BY THE CORRESPONDING GOVERNMENTAL AGENCY.

Resale of ST products with provisions different from the statements and/or technical features set forth in this document shall immediately void any warranty granted by ST for the ST product or service described herein and shall not create or extend in any manner whatsoever, any liability of ST.

ST and the ST logo are trademarks or registered trademarks of ST in various countries.

Information in this document supersedes and replaces all information previously supplied.

The ST logo is a registered trademark of STMicroelectronics. All other names are the property of their respective owners.

© 2014 STMicroelectronics - All rights reserved

STMicroelectronics group of companies

Australia - Belgium - Brazil - Canada - China - Czech Republic - Finland - France - Germany - Hong Kong - India - Israel - Italy - Japan - Malaysia - Malta - Morocco - Philippines - Singapore - Spain - Sweden - Switzerland - United Kingdom - United States of America

www.st.com

