

TDD Rejection , Thermal AGC , 2.65W , Class AB Audio Power Amplifier

Features

- Proprietary TDD Suppression Technology to Effectively Suppress TDD Noise
- Excellent PSRR : 85dB(217Hz)
- Patented Thermal AGC Function Effectively Protects the Chip from Damage in the Event of Overheating while Providing a Comfortable Listening Experience
- Excellent Pop - Click Noise Suppression
- Support 1.8V Control Logic
- 1.26W Output Power (1% THD+N,5V,8Ω Load)
- 2.65W Output Power (10% THD+N,5V,4Ω Load)
- Low Quiescent Current (2.3mA)
- Low Shutdown Current (<0.1μA)
- Operating Voltage Range: 2.5V~5.5V
- ESOP-8L Package

Applications

- Portable Electronic Devices
- GPS / MP3 / PAD
- IOT

Typical Application Circuit

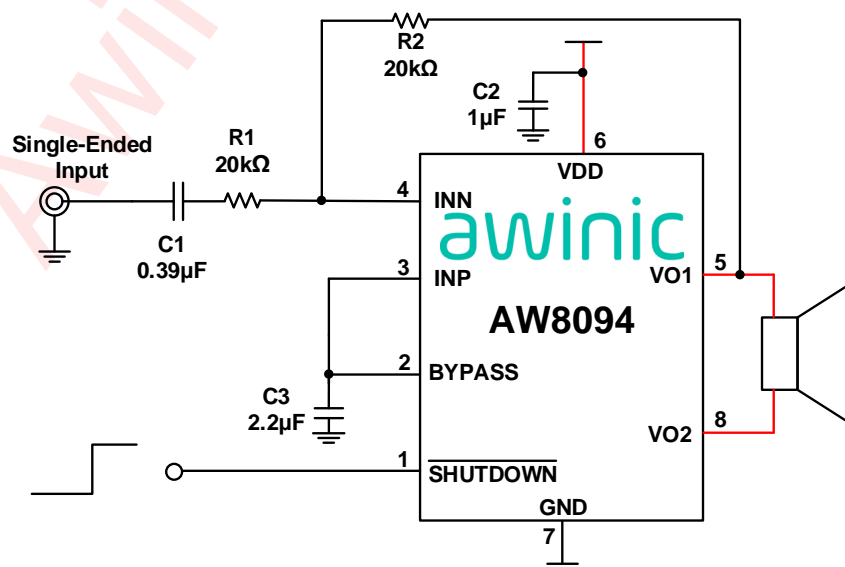

Figure 1 AW8094 Application Diagram

General Description

AW8094 is an upgraded Class AB audio power amplifier with lower noise, an upgrade to AW8090 series.

AW8094 is a dedicated TDD rejection power amplifier with Thermal AGC, 1.28W (8Ω), Class AB audio; The patented Thermal AGC function can effectively protect the device from being damaged under overheating conditions, and avoid the phenomenon that traditional AB products play music intermittently under overheating conditions. AW8094 has a built-in excellent Pop-Click noise suppression circuit to avoid Pop-Click noise during chip startup and shutdown operations.

AW8094 is capable of delivering 1.28W of continuous output power with typically 1% distortion (THD+N) when it drives an 8Ω speaker from a 5.0V power supply.

AW8094 is available in ESOP-8L Package. It operates over an ambient temperature range of -40°C to +85°C.

Pin Configuration And Top Mark

AW8094SPR (Top View)

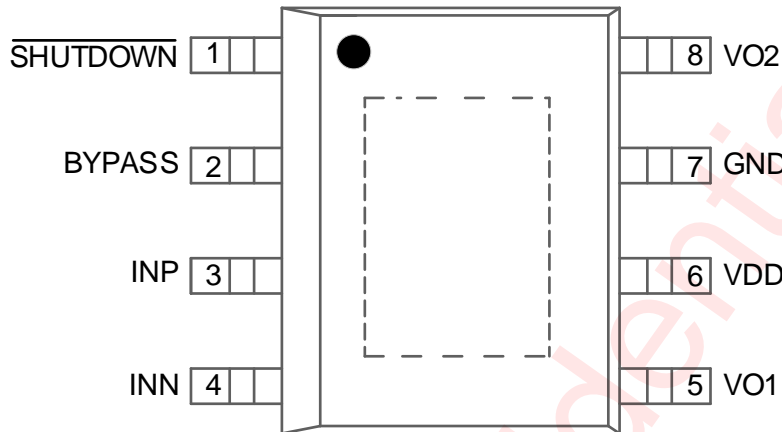

AW8094SPR Marking (Top View)

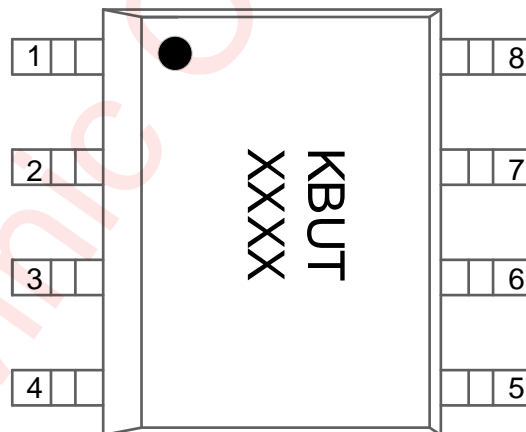

KBUT - AW8094SPR
XXXX-Production Tracing code

Figure 2 AW8094SPR Pin Diagram Top View and Device Marking

Pin Definition

No.	NAME	DESCRIPTION
1	SHUTDOWN	Turn the amplifier off when a logic low is placed on the shutdown pin
2	BYPASS	Analog common-mode level
3	INP	Positive audio input terminal
4	INN	Negative audio input terminal
5	VO1	Positive audio output terminal
6	VDD	Power supply
7	GND	Ground
8	VO2	Negative audio output terminal

Functional Block Diagram

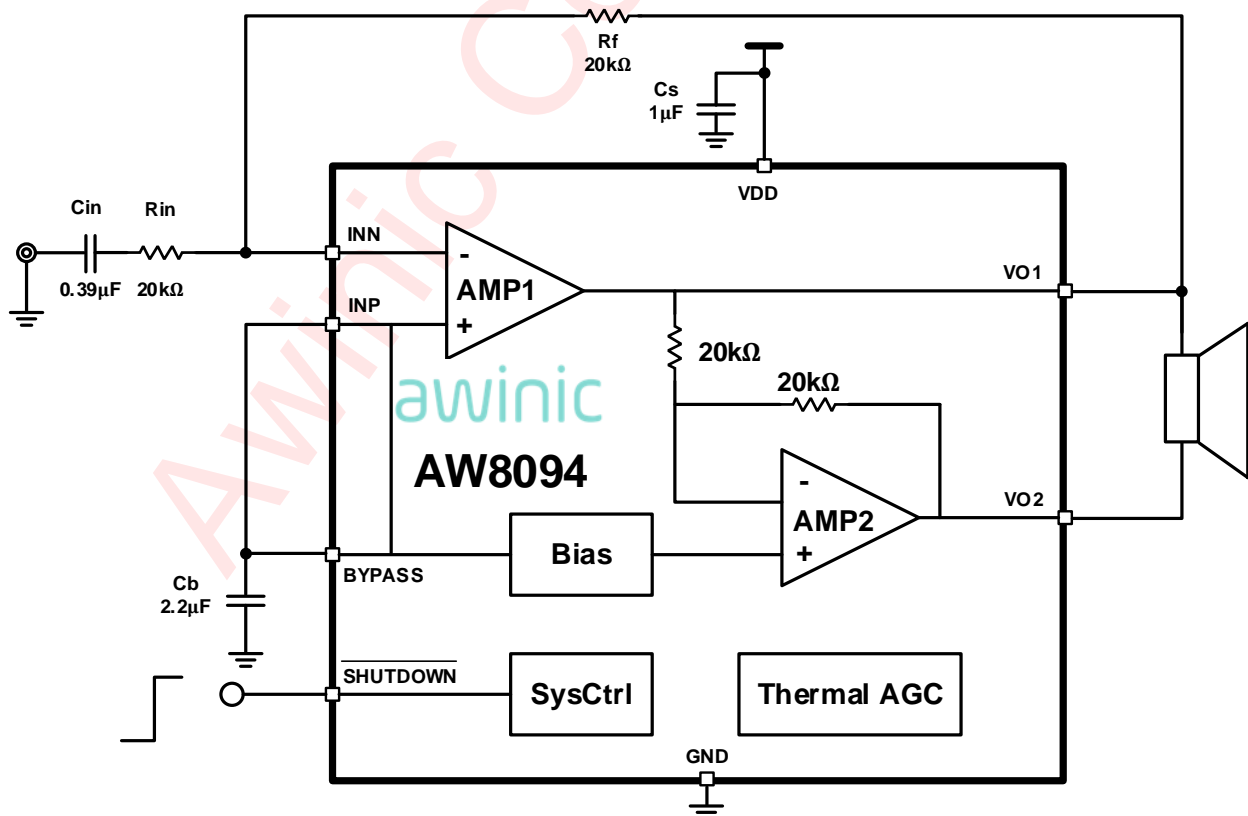

Figure 4 AW8094 Functional Block Diagram

Typical Application Circuits

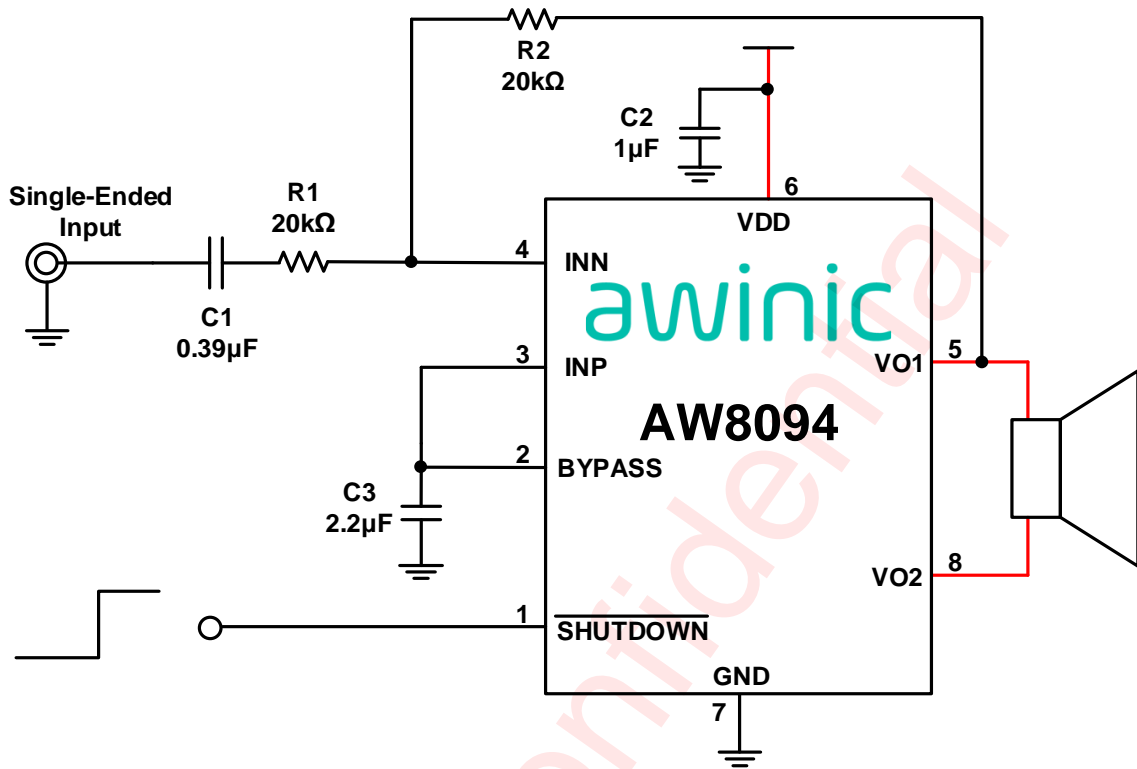

Figure 5 AW8094 Single-ended Input Application Diagram (Gain=6dB)

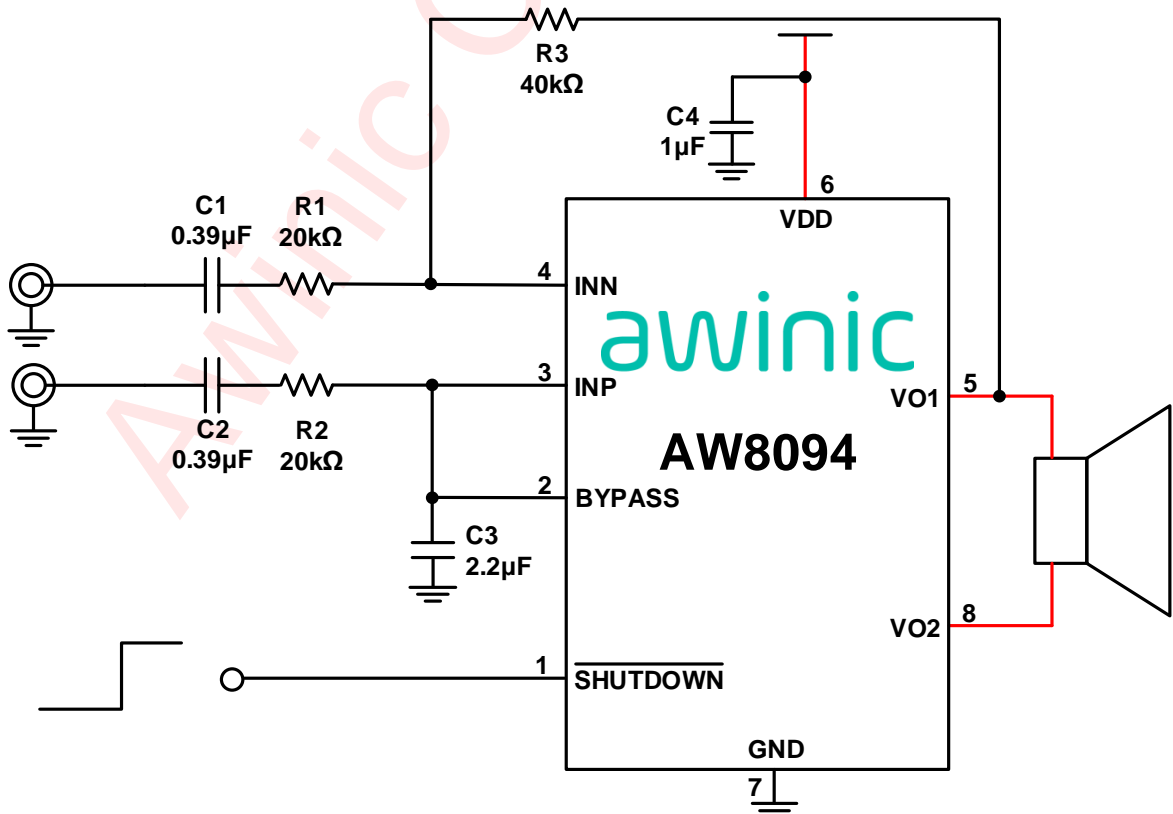

Figure 6 AW8094 Pseudo-differential Application Diagram (Gain=6dB)

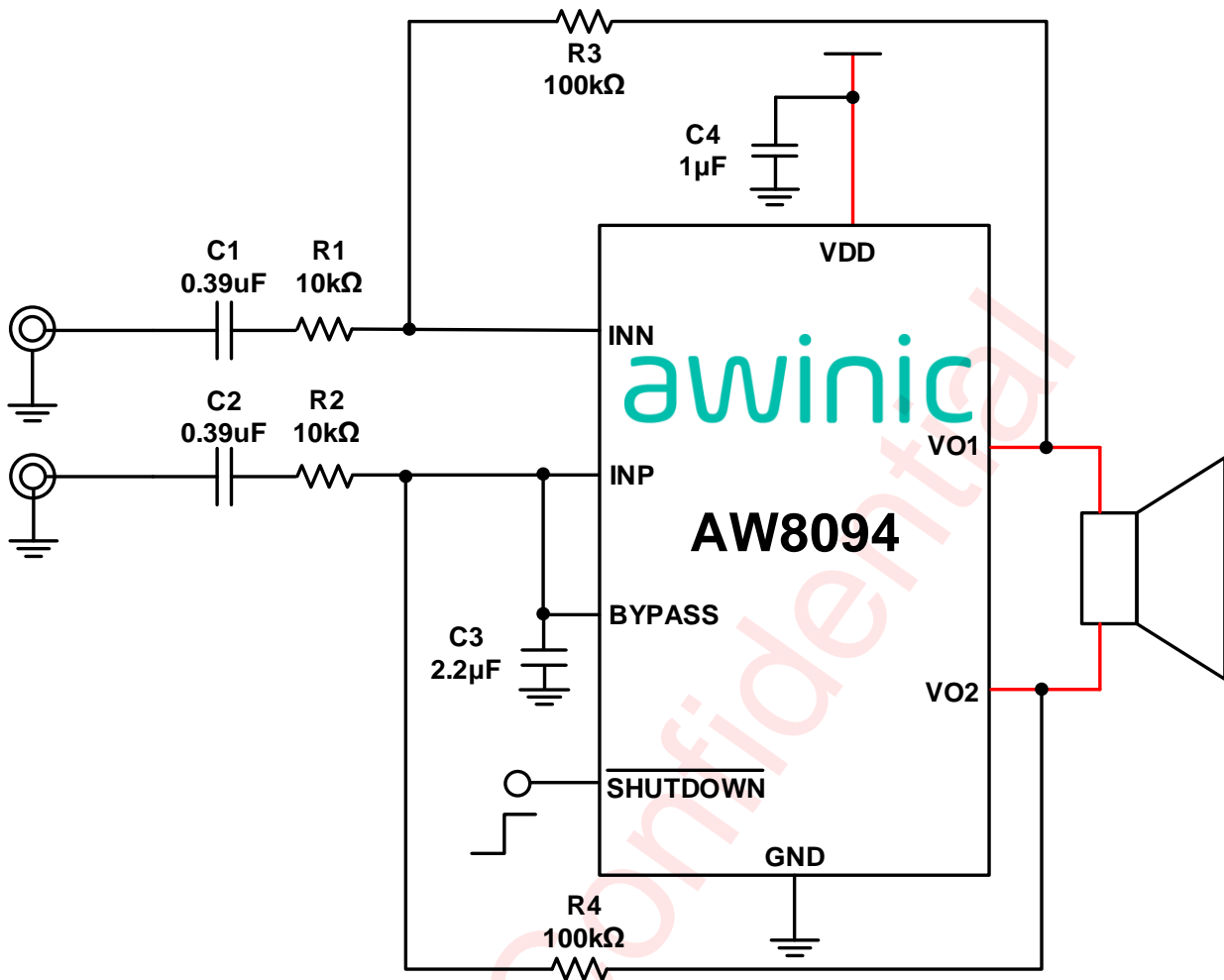

Figure 7 AW8094 Fully-differential Application Diagram (Gain=20dB)

Notice for typical application circuits:

1. Please place C3 (C_{bypass}), C4 (C_{supply}) as close to the chip as possible;
2. Bypass capacitance has a direct relationship with the system startup time and POP suppression performance, bypass capacitance is proportional to the system startup time, and the larger the capacitance value, the better the POP suppression performance, so it is recommended to choose 2.2μF best, 1μF is also acceptable.
3. The input resistance of the typical application circuit is 10kΩ or 20kΩ, and the input resistance value is adjustable, 40kΩ is also acceptable.

Ordering Information

Part Number	Temperature	Package	Marking	Moisture Sensitivity Level	Environmental Information	Delivery Form
AW8094SPR	-40 to 85 °C	ESOP-8L	KBUT	MSL3	RoHS+HF	3000 units/ Tape and Reel

Absolute Maximum Ratings^(NOTE1)

PARAMETERS	RANGE
Supply Voltage VDD	-0.3V to 6V
Input Voltage INP/INN	-0.3V to 6V
Input IO Voltage $\overline{\text{SHUTDOWN}}$	-0.3V to 6V
BYPASS Voltage	-0.3V to 6V
Output Pin Voltage VO1/VO2	-0.3V to 6V
Ambient Temperature T_{amb}	-40 to 85 °C
Storage and Junction Temperature $T_{\text{STG}}, T_{\text{J}}$	-55 to 150 °C
Package Thermal Resistance θ_{JA}	165°C/W
ESD Rating ^(NOTE 2)	
HBM (human body model)	±2kV
CDM (charged-device model)	±1.5kV
Latch-Up	
Test condition: JESD78F	+IT : 200mA -IT : -200mA

NOTE1: Conditions out of those ranges listed in "absolute maximum ratings" may cause permanent damages to the device. In spite of the limits above, functional operation conditions of the device should be within the ranges listed in "recommended operating conditions". Exposure to absolute-maximum-rated conditions for prolonged periods may affect device reliability.

NOTE2: The human body model is a 100pF capacitor discharged through a 1.5kΩ resistor into each pin. Test method: ESDA/JEDEC JS-001-2023. Test method of the charge device model: ESDA/JEDEC JS-002-2022

Electrical Characteristics

Test condition : $T_A=25^{\circ}\text{C}$ for typical values (unless otherwise noted)

PARAMETER	TEST CONDITION	MIN	TYP	MAX	UNIT	
INPUT SOURCE AND BATTERY PROTECTION						
V_{DD}	Supply voltage	2.5		5.5	V	
V_{IH}	SHUTDOWN high level input	1.3		VDD	V	
V_{IL}	SHUTDOWN low level input	0		0.54	V	
I_{SD}	Shutdown current	$V_{DD}=3.6\text{V}, \text{SHUTDOWN}=0$		0.06	μA	
I_Q	Quiescent current	$V_{DD}=3.6\text{V}, \text{SHUTDOWN}=1$		2.3	mA	
TIMING						
T_{WU}	Wake-up time	$V_{DD}=3.6\text{V}, C_{BYPASS}=2.2\mu\text{F}$		200	220	ms
		$V_{DD}=4.2\text{V}, C_{BYPASS}=2.2\mu\text{F}$		220	240	ms
T_{TG}	Thermal AGC start-up temperature threshold		145		$^{\circ}\text{C}$	
T_{TGR}	Thermal AGC exit temperature threshold		120		$^{\circ}\text{C}$	
T_{SD}	Overtemperature protection threshold		160		$^{\circ}\text{C}$	
T_{SDR}	Overtemperature protection exit threshold		120		$^{\circ}\text{C}$	
CLASS-AB(Single-ended Input、Pseudo-differential Application)						
P_o	Output power ($f = 1\text{kHz}$; Gain = 6 dB)	THD+N=10%, $R_L=8\Omega, V_{DD}=5\text{V}$		1.6		W
		THD+N=1%, $R_L=8\Omega, V_{DD}=5\text{V}$		1.26		W
		THD+N=10%, $R_L=6\Omega, V_{DD}=5\text{V}$		2.0		W
		THD+N=1%, $R_L=6\Omega, V_{DD}=5\text{V}$		1.6		W
		THD+N=10%, $R_L=4\Omega, V_{DD}=5\text{V}$		2.65		W
		THD+N=1%, $R_L=4\Omega, V_{DD}=5\text{V}$		2.12		W
		THD+N=10%, $R_L=8\Omega, V_{DD}=4.2\text{V}$		1.12		W
		THD+N=1%, $R_L=8\Omega, V_{DD}=4.2\text{V}$		0.9		W
		THD+N=10%, $R_L=4\Omega, V_{DD}=4.2\text{V}$		1.9		W
		THD+N=1%, $R_L=4\Omega, V_{DD}=4.2\text{V}$		1.5		W
		THD+N=1%, $R_L=8\Omega, V_{DD}=3.6\text{V}$		0.67		W
		THD+N=1%, $R_L=4\Omega, V_{DD}=3.6\text{V}$		1.1		W
E_N	Speaker Output noise	Gain = 6 dB , 20Hz to 20kHz , A-weighting		17	μV	
V_{OS}	Output offset voltage	No input		-10	+10	mV
THD+N	Total harmonic distortion + noise ($f = 1\text{kHz}$; Gain = 6 dB)	$P_o=1\text{W}, R_L=8\Omega, V_{DD}=5\text{V}$		0.12		%
		$P_o=0.5\text{W}, R_L=8\Omega, V_{DD}=4.2\text{V}$		0.12		%
		$P_o=0.25\text{W}, R_L=8\Omega, V_{DD}=4.2\text{V}$		0.12		%

PARAMETER		TEST CONDITION	MIN	TYP	MAX	UNIT
		$P_O=0.25W, R_L=8\Omega, V_{DD}=3.6V$		0.12		%
		$P_O=0.5W, R_L=6\Omega, V_{DD}=4.2V$		0.15		%
		$P_O=1W, R_L=4\Omega, V_{DD}=4.2V$		0.22		%
PSRR	Power supply rejection ratio	$V_{pp_sin}=200mV, 217Hz$		85		dB
		$V_{pp_sin}=200mV, 1kHz$		76		dB
CLASS-AB(Fully-differential Application)						
P_O	Output power ($f = 1kHz$; Gain = 6 dB)	THD+N=10%, $R_L=8\Omega, V_{DD}=5V$		1.6		W
		THD+N=1%, $R_L=8\Omega, V_{DD}=5V$		0.9		W
		THD+N=10%, $R_L=4\Omega, V_{DD}=5V$		2.65		W
		THD+N=10%, $R_L=8\Omega, V_{DD}=4.2V$		1.1		W
		THD+N=10%, $R_L=4\Omega, V_{DD}=4.2V$		1.85		W
		THD+N=10%, $R_L=8\Omega, V_{DD}=5V$		1.6		W
	Output power ($f = 1kHz$; Gain = 20 dB)	THD+N=1%, $R_L=8\Omega, V_{DD}=5V$		1.1		W
		THD+N=10%, $R_L=4\Omega, V_{DD}=5V$		2.65		W
		THD+N=1%, $R_L=4\Omega, V_{DD}=5V$		1.6		W
		THD+N=10%, $R_L=8\Omega, V_{DD}=4.2V$		1.1		W
		THD+N=10%, $R_L=4\Omega, V_{DD}=4.2V$		1.85		W
		THD+N=10%, $R_L=8\Omega, V_{DD}=5V$		1.6		W
E_N	Speaker Output noise	Gain = 6 dB , 20Hz to 20kHz , A-weighting		23		μV
		Gain = 20 dB , 20Hz to 20kHz , A-weighting		70		μV
THD+N	Total Harmonic Distortion + Noise ($f = 1kHz$; Gain = 6 dB)	$P_O=0.5W, R_L=8\Omega, V_{DD}=4.2V$		0.13		%
		$P_O=1W, R_L=8\Omega, V_{DD}=5V$		0.25		%
	Total Harmonic Distortion + Noise ($f = 1kHz$; Gain = 20 dB)	$P_O=0.5W, R_L=8\Omega, V_{DD}=4.2V$		0.26		%

Typical Characteristics

T_A=25°C, Single-ended Input application

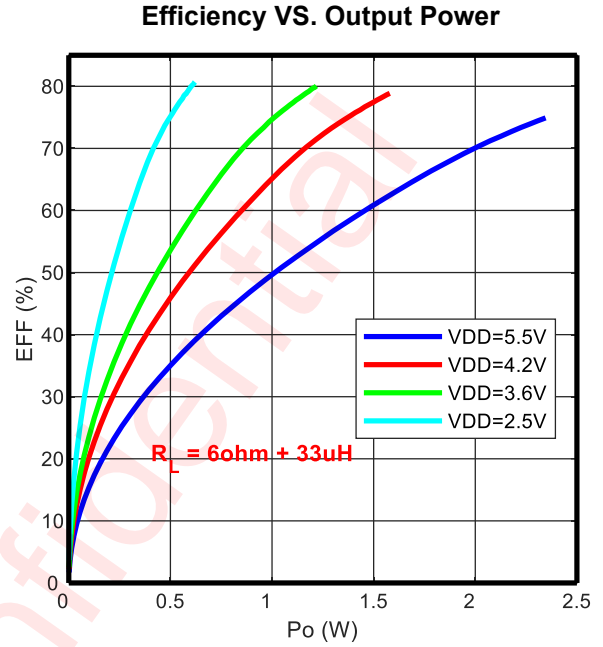
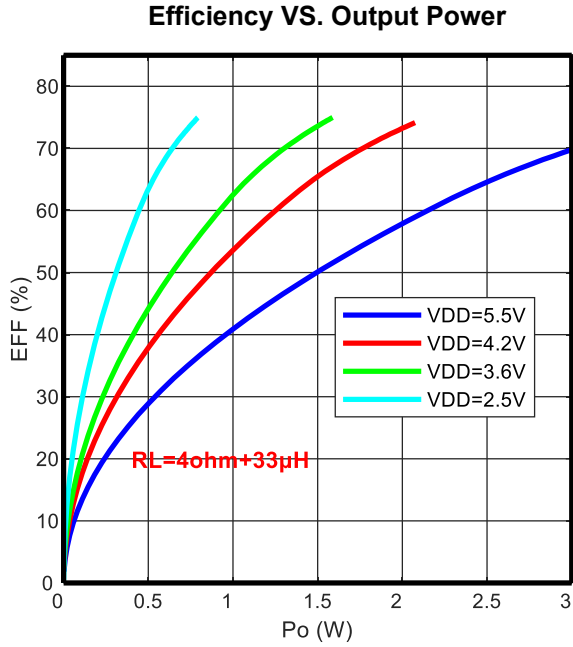

Efficiency VS. Output Power

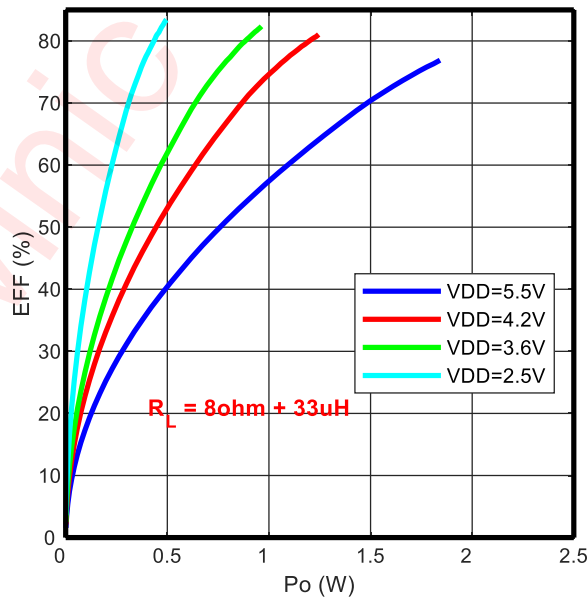

Gain VS. Frequency

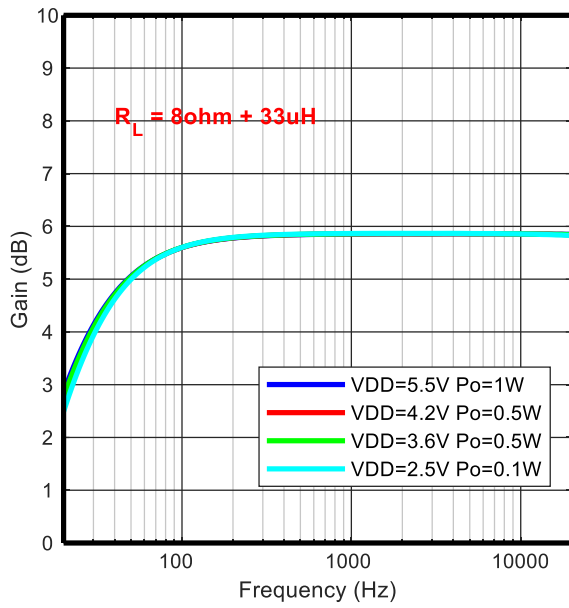

PSRR VS. Frequency

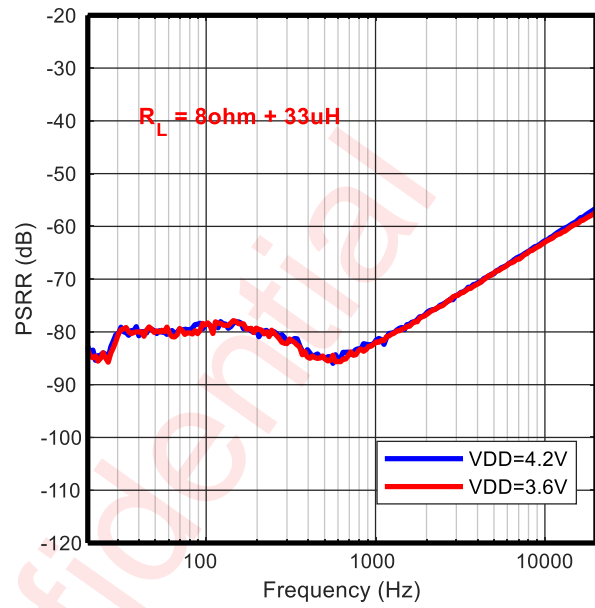

THD+N VS. Frequency

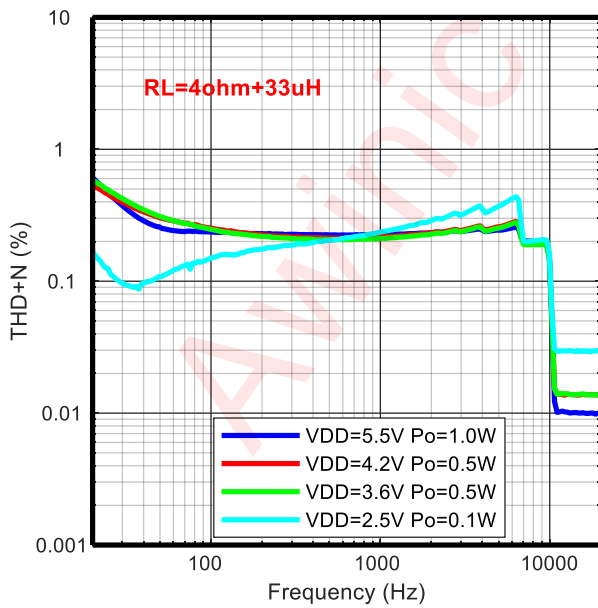

THD+N VS. Frequency

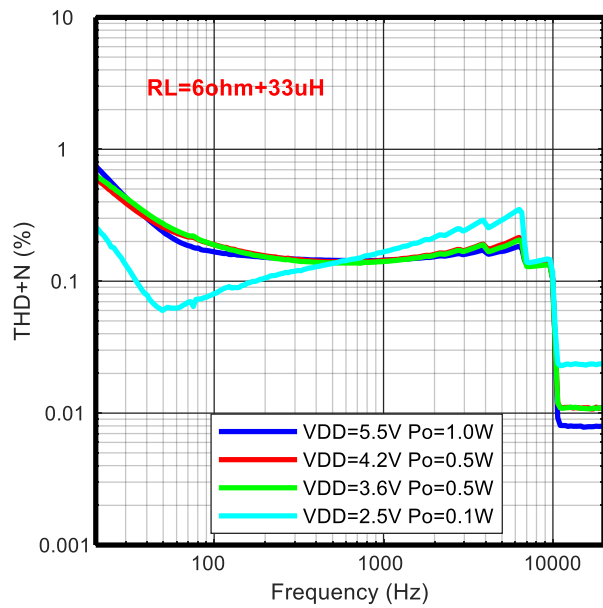

THD+N VS. Frequency

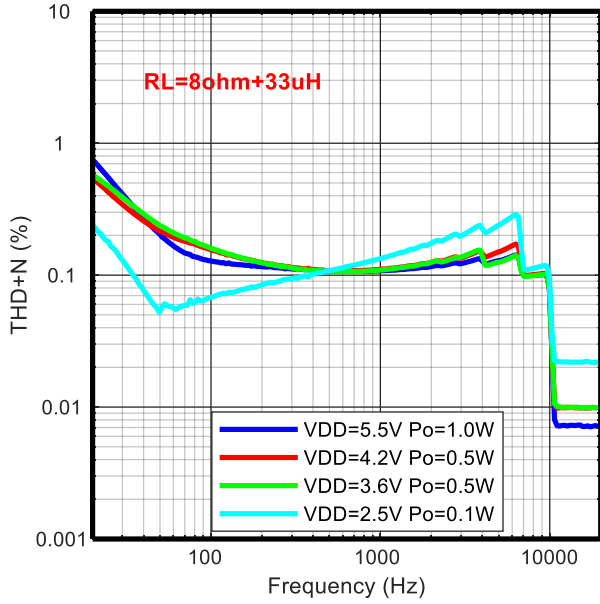

THD+N VS. Output Power

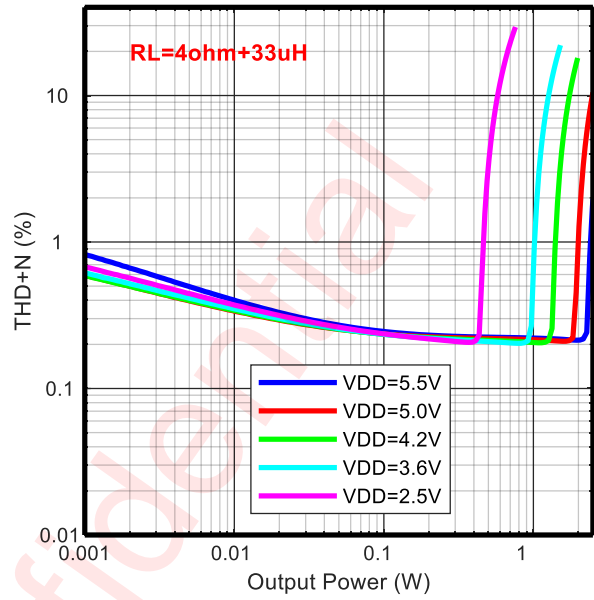

THD+N VS. Output Power

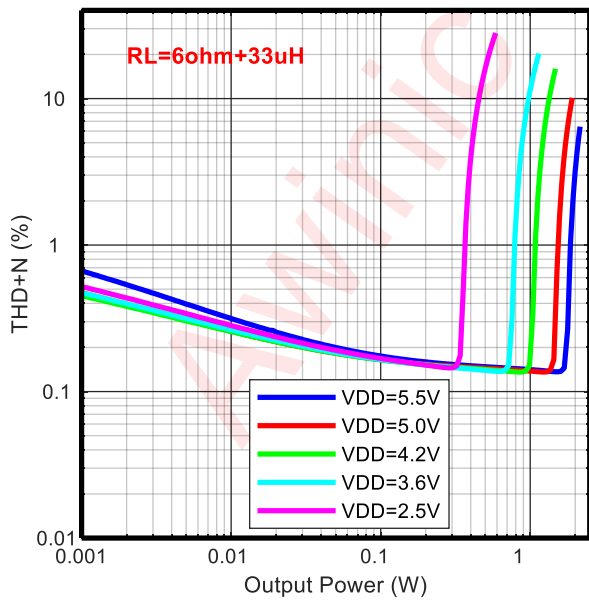

THD+N VS. Output Power

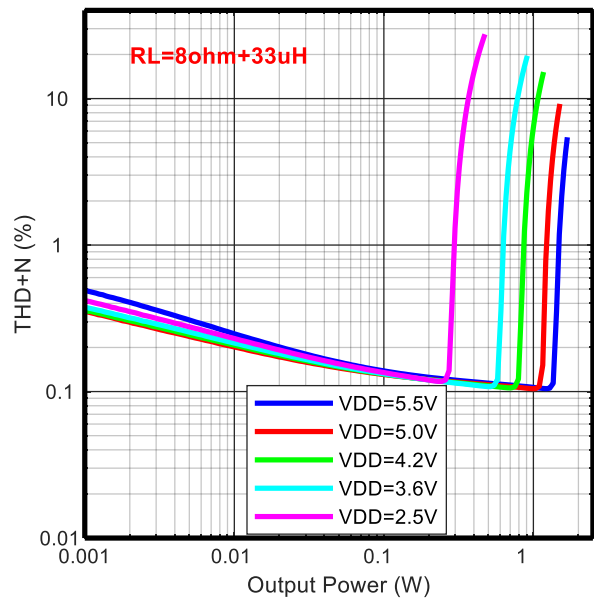

T_A=25°C, Fully-differential application

Gain VS. Frequency

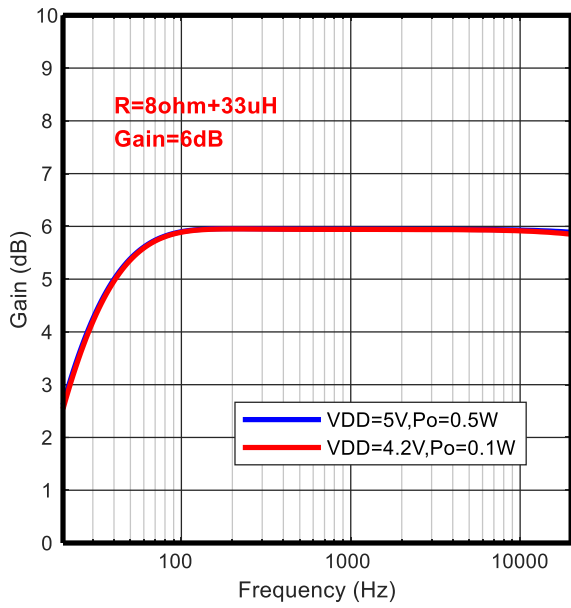

Gain VS. Frequency

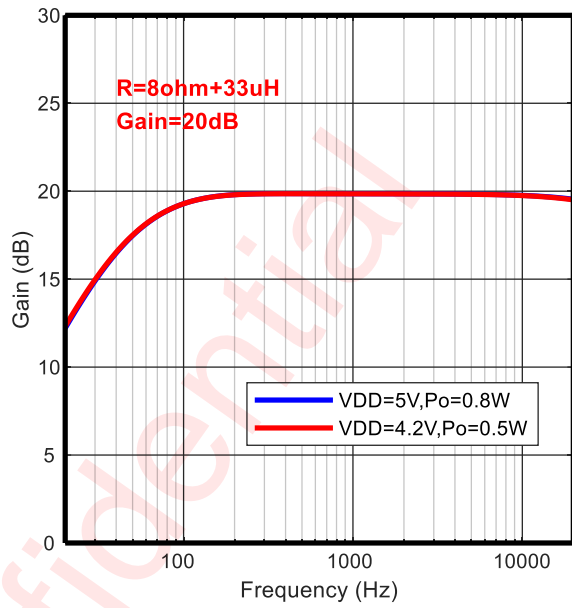

THD+N VS. Frequency

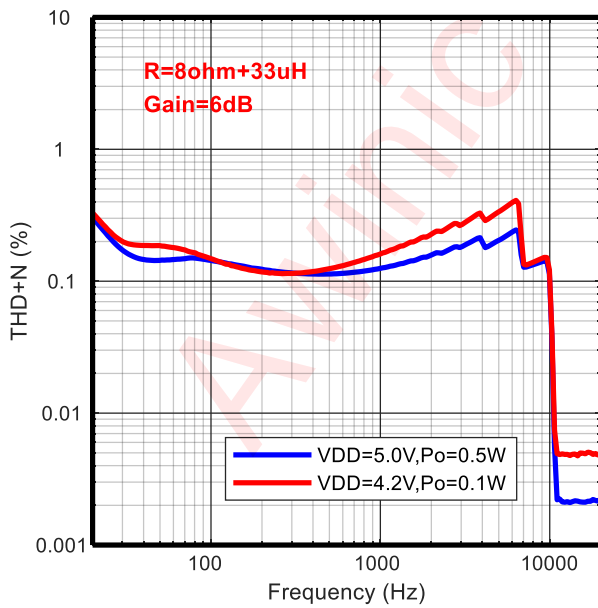

THD+N VS. Frequency

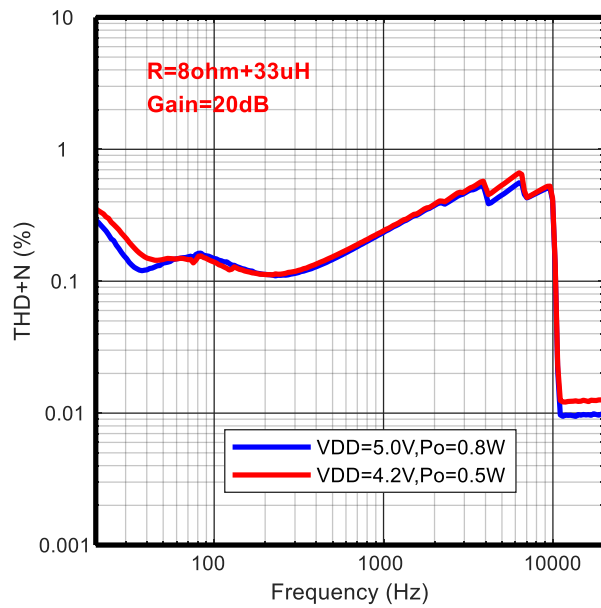

THD+N VS. Output Power

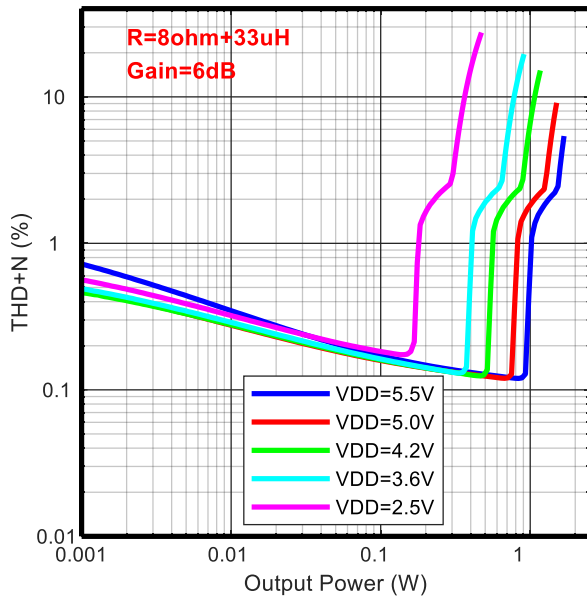

THD+N VS. Output Power

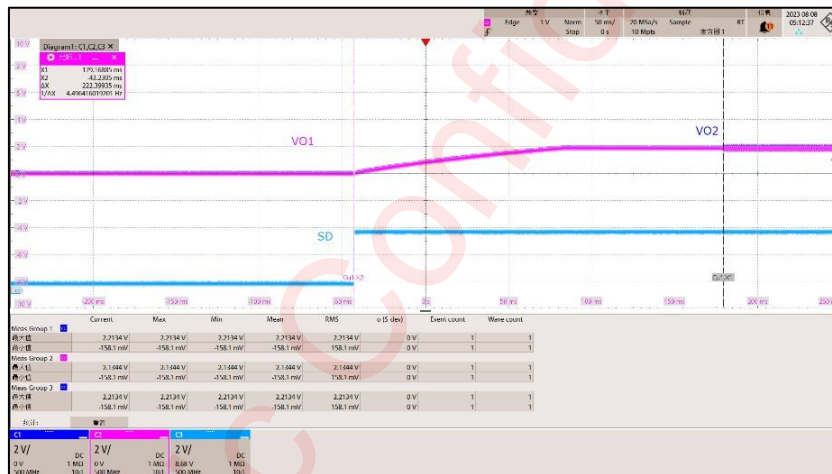
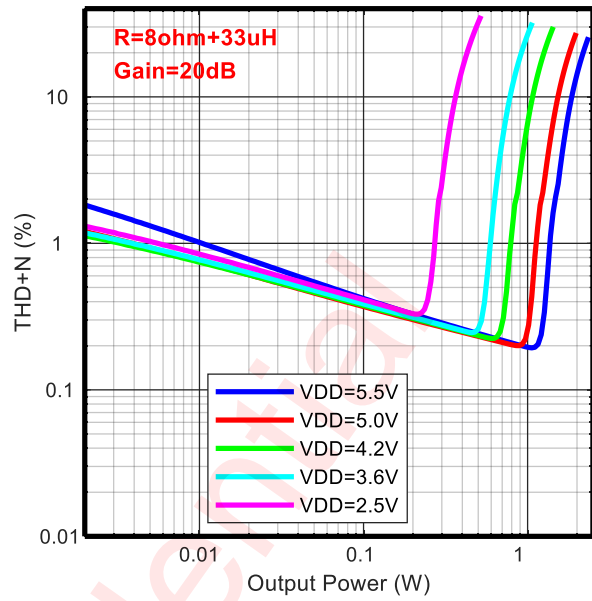

Figure 8 AW8094 Startup Timing

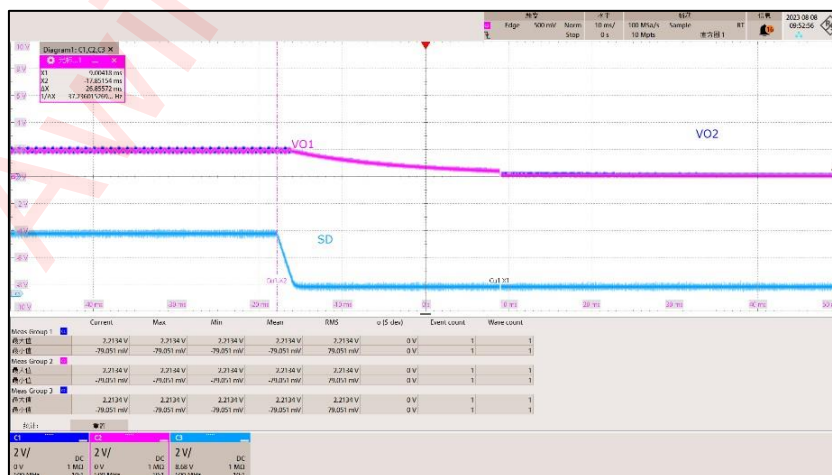

Figure 9 AW8094 Shutdown Timing

Application Information

Supply Decoupling Capacitor (C_s)

A good decoupling capacitor can improve the efficiency and the best performance of the power amplifier. At the same time, in order to get good high frequency transient performance, the ESR value of the capacitor should be as small as possible. Low ESR (equivalent-series-resistance) X7R or X5R ceramic capacitors are recommended. Generally, 10 μ F ceramic capacitors are used to bypass the VDD to the ground, and the decoupling capacitor should be placed as close to the VDD chip as possible in the layout. If you want to filter out low-frequency noise better, you need to add a 10 μ F or greater decoupling capacitor depending on your application. Meanwhile, a 33pF~0.1 μ F ceramic capacitor is placed on the pin of the power supply to filter the high frequency interference on the power supply.

Input Capacitor- C_{in} (Input High-pass Cutoff Frequency)

The input capacitors and input resistors form a high-pass filter to filter out the DC component of the input signal. The -3dB frequency points of the high pass filter is shown below:

$$f_H(-3dB) = \frac{1}{2 * \pi * R_{in} * C_{in}} \text{ (Hz)}$$

The selection of a smaller C_{in} capacitor in the application helps to filter out noise, which comes from the input coupling, and the smaller capacitor is advantageous to reduce the pop-click noise when the power amplifier turn on. Better matching of the input capacitors improves performance of the circuit and also helps to suppress pop-click noise. A capacitor value deviation of 10% or better capacitance is recommended. C_{in} can be selected from 15nF to 0.39 μ F as needed.

Take typical application as an example, the input high-pass cutoff frequency is calculated as below:

$$f_H(-3dB) = \frac{1}{2 * \pi * R_{in} * C_{in}} = \frac{1}{2 * \pi * 20k\Omega * 0.39\mu F} \text{ (Hz)} = 20\text{Hz}$$

Input resistance & Feedback resistance (Gain setting)

When applied as single-ended input application, the gain setting of system:

$$A_v = 2 * \frac{R_f}{R_{in}} \text{ (V/V)}$$

When applied as pseudo-differential application, the gain setting of system:

$$A_v = \frac{R_f}{R_{in}} \text{ (V/V)}$$

It is generally recommended that A_v be set between 2~10 V/V, so that you can get better music playback effect.

When applied as fully-differential application, the gain setting of system:

$$A_v = \frac{R_f}{R_{in}} \text{ (V/V)}$$

It is recommended that A_v be set to 10V/V, so as to obtain better music playback and ensure better electrical performance such as THD+N.

Tape And Reel Information

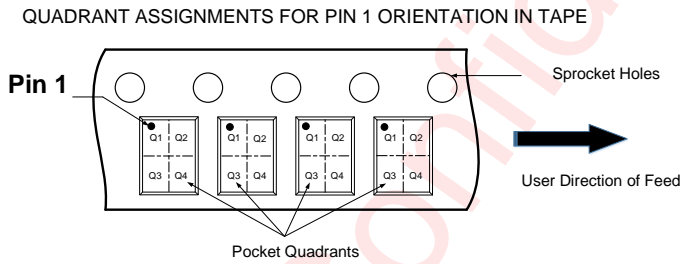
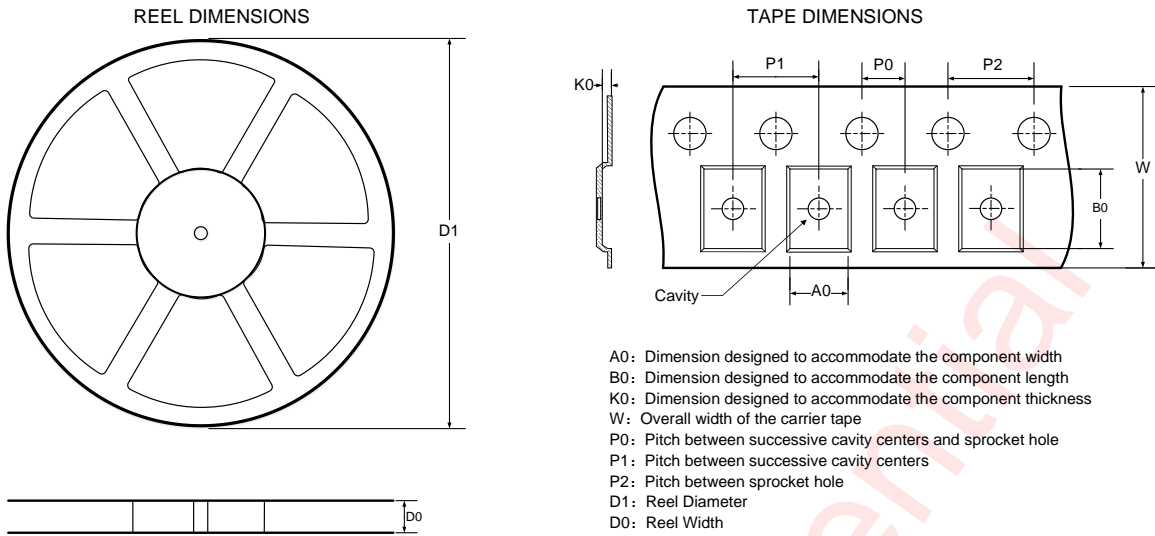

Note: The above picture is for reference only. Please refer to the value in the table below for the actual size

DIMENSIONS AND PIN1 ORIENTATION

D1 (mm)	D0 (mm)	A0 (mm)	B0 (mm)	K0 (mm)	P0 (mm)	P1 (mm)	P2 (mm)	W (mm)	Pin1 Quadrant
330	12.4	6.4	5.35	2	2	8	4	12	Q1

All dimensions are nominal

Package Description

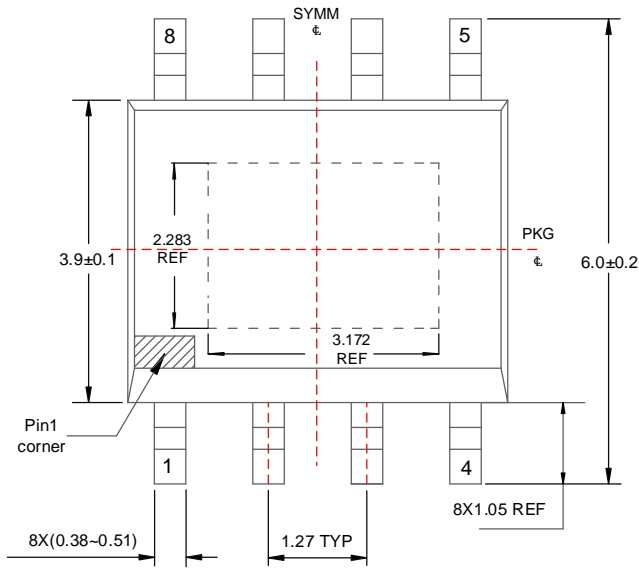

Top View

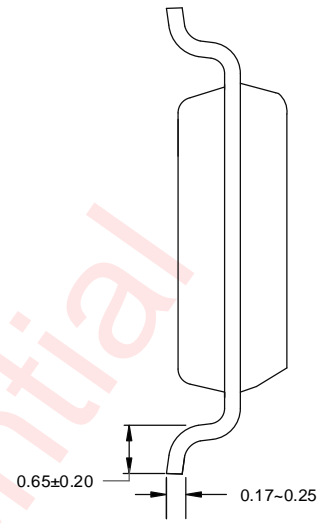

Side View

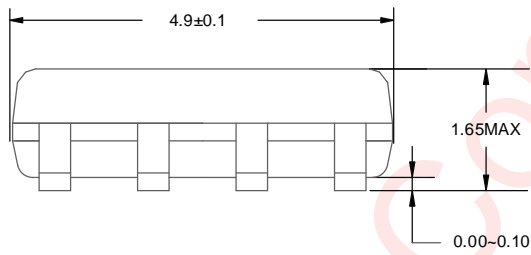

Side View

Unit: mm

Land Pattern Data

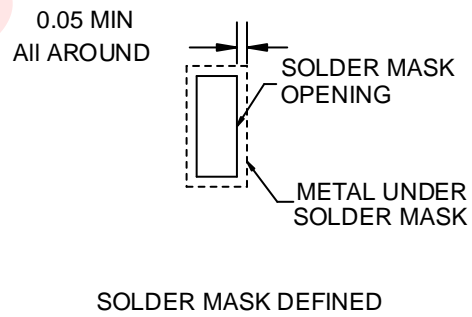
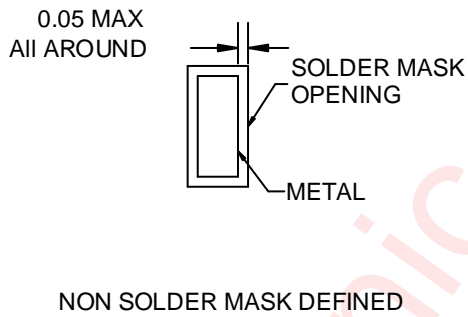
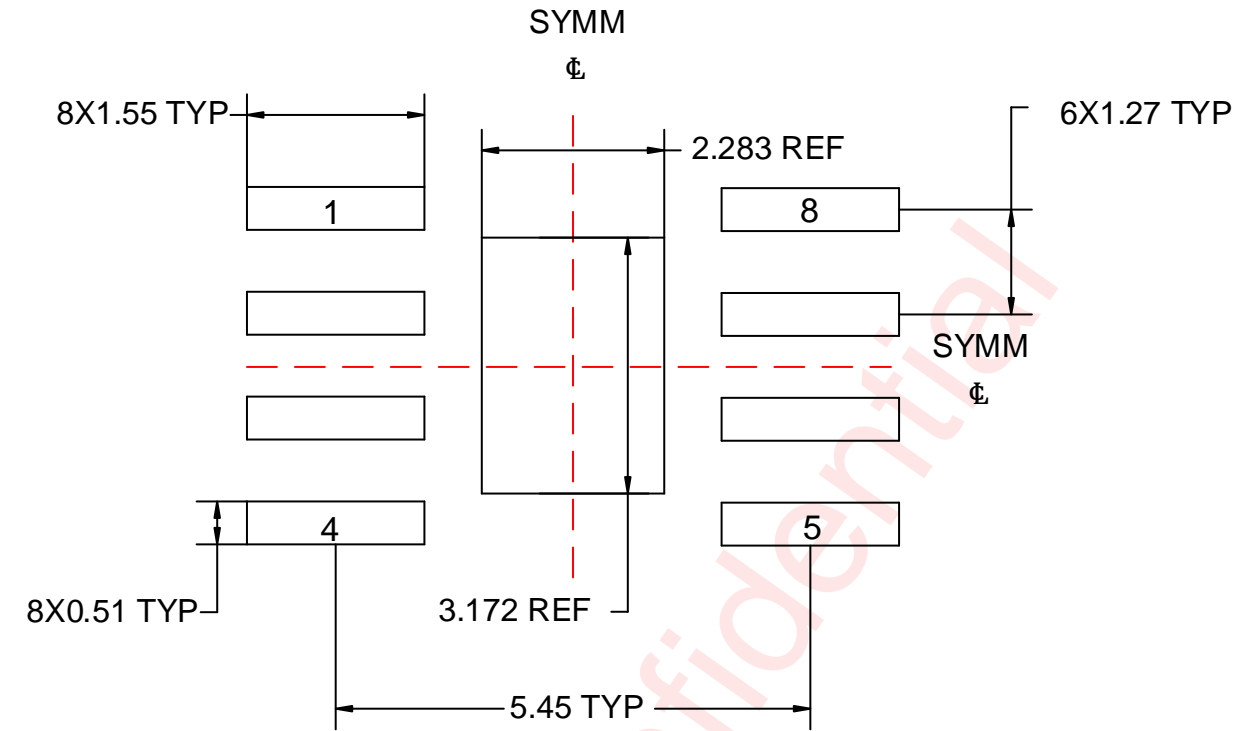

Unit: mm

Revision History

Version	Date	Change Record
V1.0	Apr.2024	Officially released

Awinic Confidential

Disclaimer

All trademarks are the property of their respective owners. Information in this document is believed to be accurate and reliable. However, Shanghai AWINIC Technology Co., Ltd (AWINIC Technology) does not give any representations or warranties, expressed or implied, as to the accuracy or completeness of such information and shall have no liability for the consequences of use of such information.

AWINIC Technology reserves the right to make changes to information published in this document, including without limitation specifications and product descriptions, at any time and without notice. Customers shall obtain the latest relevant information before placing orders and shall verify that such information is current and complete. This document supersedes and replaces all information supplied prior to the publication hereof.

AWINIC Technology products are not designed, authorized or warranted to be suitable for use in medical, military, aircraft, space or life support equipment, nor in applications where failure or malfunction of an AWINIC Technology product can reasonably be expected to result in personal injury, death or severe property or environmental damage. AWINIC Technology accepts no liability for inclusion and/or use of AWINIC Technology products in such equipment or applications and therefore such inclusion and/or use is at the customer's own risk.

Applications that are described herein for any of these products are for illustrative purposes only. AWINIC Technology makes no representation or warranty that such applications will be suitable for the specified use without further testing or modification.

All products are sold subject to the general terms and conditions of commercial sale supplied at the time of order acknowledgement.

Nothing in this document may be interpreted or construed as an offer to sell products that is open for acceptance or the grant, conveyance or implication of any license under any copyrights, patents or other industrial or intellectual property rights.

Reproduction of AWINIC information in AWINIC data books or data sheets is permissible only if reproduction is without alteration and is accompanied by all associated warranties, conditions, limitations, and notices. AWINIC is not responsible or liable for such altered documentation. Information of third parties may be subject to additional restrictions.

Resale of AWINIC components or services with statements different from or beyond the parameters stated by AWINIC for that component or service voids all express and any implied warranties for the associated AWINIC component or service and is an unfair and deceptive business practice. AWINIC is not responsible or liable for any such statements.