

Surface Mount Aluminum Electrolytic Capacitors

NAZJ Series

FEATURES

- CYLINDRICAL V-CHIP CONSTRUCTION FOR SURFACE MOUNTING
- REDUCED CASE SIZE (SMALLER THEN NAZT)
- LOW ESR & HIGH RIPPLE CURRENT AT 100KHz
- LOAD LIFE (2,000 HOURS @ +105°C)
- DESIGNED FOR AUTOMATIC MOUNTING AND REFLOW SOLDERING
- **MEETS THE REQUIREMENTS OF AEC-Q200***

*Contact NIC for supporting test data

SAC Alloy Compatible
235°C ~ 260°C

RoHS Compliant
includes all homogeneous materials



*See Part Number System for Details

CHARACTERISTICS

Rated Voltage Rating	6.3 ~ 50Vdc						
Rated Capacitance Range	10 ~ 1,800μF						
Operating Temp. Range	-55 ~ +105°C						
Capacitance Tolerance	±20% (M)						
Max. Leakage Current After 2 Minutes @ 20°C	0.01CV or 3μA whichever is greater						
Dissipation Factor	W.V. (Vdc)	6.3	10	16	25	35	50
	S.V. (Vdc)	8.0	13	20	32	44	63
	Tan δ @ 120Hz/20°C	0.26	0.19	0.16	0.14	0.12	0.10
Low Temperature Stability Impedance Ratio @ 120Hz	W.V. (Vdc)	6.3	10	16	25	35	50
	Z-25°C/Z+20°C	2	2	2	2	2	2
	Z-40°C/Z+20°C	3	3	3	3	3	3
Load Life Test @ 105°C 2,000 hours	Z-55°C/Z+20°C	4	4	4	3	3	3
	Capacitance Change	Within ±30% of initial measured value					
	Tan δ	Less than ±200% of the specified maximum value					
	Leakage Current	Less than the specified maximum value					

LOW ESR COMPONENT
LIQUID ELECTROLYTE
For Performance Data see www.LowESR.com

PART NUMBER SYSTEM

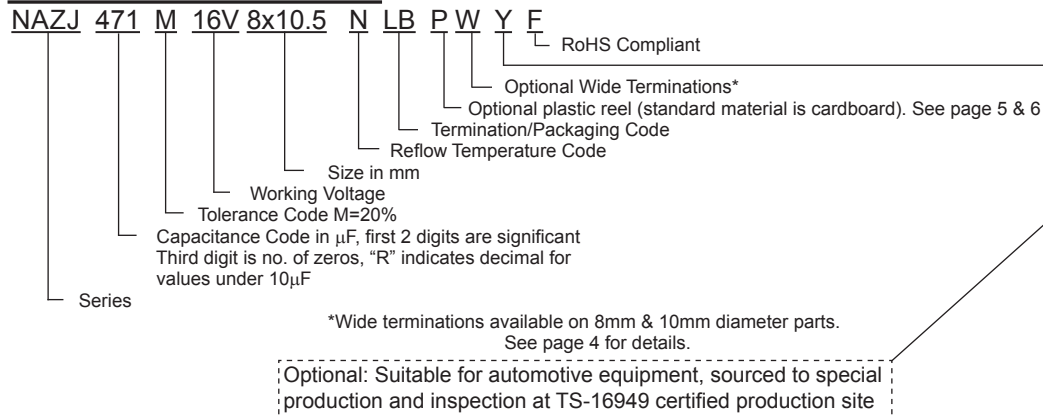

DIMENSIONS (mm)

Case Size	φD±0.5	L max.	A±0.2	B±0.2	I±0.3	W	P±0.3
4x6.1	4.0	6.1	4.3	4.3	1.8	0.50~0.80	1.0
5x6.1	5.0	6.1	5.3	5.3	2.2	0.50~0.80	1.5
6.3x6.1	6.3	6.1	6.6	6.6	2.6	0.50~0.80	1.8
6.3x8	6.3	8.0	6.6	6.6	2.6	0.50~0.80	1.8
8x6.5	8.0	6.5	8.3	8.3	3.4	0.50~0.80	2.2
8x10.5	8.0	10.5	8.3	8.3	3.1	0.7~1.1	3.1
10x10.5	10.0	10.5	10.3	10.3	3.2	0.7~1.4	4.6
10x14	10.0	14.0	10.3	10.3	3.2	0.7~1.4	4.6

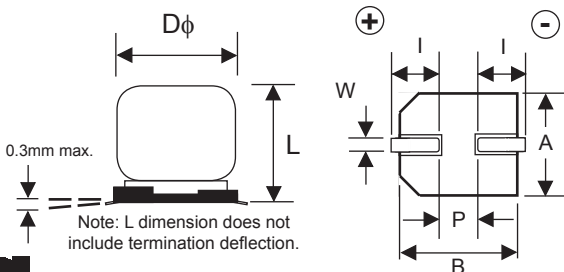

PEAK REFLOW TEMPERATURE CODES

Code	Peak Reflow Temperature
N	260°C*

*Special conditions on page 3.

TERMINATION FINISH & PACKAGING OPTIONS CODES

Code	Finish & Reel Size
B	Sn-Bi Finish & 13" Reel
LB	Sn-Bi Finish & 15" Reel

*See part number standard values table for appropriate code



STANDARD VALUES, CASE SIZES AND SPECIFICATIONS

NIC Part Number	Cap. (μF)	W.V. (Vdc)	Dissipation Factor (Tan δ)	Max. ESR (Ω) 100KHz, +20°C	Max. Ripple Current (mA) +105°C, 100KHz	Load Life Hours @ +105°C	
NAZJ220M6.3V4X6.1NBF	22	6.3	0.26	0.85	160	2,000	
NAZJ470M6.3V4X6.1NBF	47		0.26	0.85	160	2,000	
NAZJ470M6.3V5X6.1NBF	47		0.26	0.36	240	2,000	
NAZJ101M6.3V5X6.1NBF	100		0.26	0.36	240	2,000	
NAZJ101M6.3V6.3X6.1NLF	100		0.26	0.26	300	2,000	
NAZJ221M6.3V6.3X6.1NLF	220		0.26	0.26	300	2,000	
NAZJ331M6.3V6.3X8NLF	330		0.26	0.16	600	2,000	
NAZJ331M6.3V8X6.5NBF	330		0.26	0.18	500	2,000	
NAZJ471M6.3V8X10.5NLF	470		0.26	0.08	850	2,000	
NAZJ102M6.3V8X10.5NLF	1000		0.26	0.08	850	2,000	
NAZJ152M6.3V10X10.5NLF	1500		0.26	0.06	1190	2,000	
NAZJ182M6.3V10X10.5NLF	1800		0.26	0.08	850	2,000	
NAZJ220M10V4X6.1NBF	22		10	0.19	0.85	160	2,000
NAZJ330M10V4X6.1NBF	33			0.19	0.85	160	2,000
NAZJ330M10V5X6.1NBF	33	0.19		0.36	240	2,000	
NAZJ151M10V6.3X6.1NLF	150	0.19		0.26	300	2,000	
NAZJ221M10V6.3X8NLF	220	0.19		0.16	600	2,000	
NAZJ221M10V8X6.5NBF	220	0.19		0.18	500	2,000	
NAZJ331M10V8X10.5NLF	330	0.19		0.08	850	2,000	
NAZJ471M10V8X10.5NLF	470	0.19		0.08	850	2,000	
NAZJ681M10V8X10.5NLF	680	0.19		0.08	850	2,000	
NAZJ102M10V10X10.5NLF	1000	0.19		0.06	1190	2,000	
NAZJ122M10V10X10.5NLF	1200	0.19		0.08	850	2,000	
NAZJ152M10V10X14NLF	1500	0.19		0.06	1190	2,000	
NAZJ100M16V4X6.1NBF	10	16		0.16	0.85	160	2,000
NAZJ220M16V4X6.1NBF	22			0.16	0.85	160	2,000
NAZJ220M16V5X6.1NBF	22		0.16	0.36	240	2,000	
NAZJ470M16V5X6.1NBF	47		0.16	0.36	240	2,000	
NAZJ470M16V6.3X6.1NLF	47		0.16	0.26	300	2,000	
NAZJ680M16V6.3X6.1NLF	68		0.16	0.26	300	2,000	
NAZJ101M16V6.3X6.1NLF	100		0.16	0.26	300	2,000	
NAZJ101M16V6.3X8NLF	100		0.16	0.16	600	2,000	
NAZJ151M16V6.3X8NLF	150		0.16	0.16	600	2,000	
NAZJ221M16V6.3X8NLF	220		0.16	0.16	600	2,000	
NAZJ221M16V8X6.5NBF	220		0.16	0.18	500	2,000	
NAZJ331M16V8X10.5NLF	330		0.16	0.08	850	2,000	
NAZJ471M16V8X10.5NLF	470		0.16	0.08	850	2,000	
NAZJ681M16V10X10.5NLF	680		0.16	0.06	1190	2,000	
NAZJ821M16V10X10.5NLF	820	0.16	0.08	850	2,000		
NAZJ102M16V10X14NLF	1000	0.16	0.06	1190	2,000		
NAZJ100M25V4X6.1NBF	10	25	0.14	0.85	160	2,000	
NAZJ220M25V5X6.1NBF	22		0.14	0.36	240	2,000	
NAZJ330M25V5X6.1NBF	33		0.14	0.36	240	2,000	
NAZJ330M25V6.3X6.1NLF	33		0.14	0.26	300	2,000	
NAZJ470M25V6.3X6.1NLF	47		0.14	0.26	300	2,000	
NAZJ680M25V6.3X6.1NLF	68		0.14	0.26	300	2,000	
NAZJ101M25V6.3X8NLF	100		0.14	0.16	600	2,000	
NAZJ101M25V8X6.5NBF	100		0.14	0.18	500	2,000	
NAZJ151M25V8X10.5NLF	150		0.14	0.08	850	2,000	
NAZJ221M25V8X10.5NLF	220		0.14	0.08	850	2,000	
NAZJ331M25V8X10.5NLF	330		0.14	0.08	850	2,000	
NAZJ471M25V10X10.5NLF	470		0.14	0.06	1190	2,000	
NAZJ561M25V10X10.5NLF	560		0.14	0.08	850	2,000	
NAZJ681M25V10X14NLF	680		0.14	0.06	1190	2,000	
NAZJ100M35V4X6.1NBF	10	35	0.12	0.85	160	2,000	
NAZJ220M35V5X6.1NBF	22		0.12	0.36	240	2,000	
NAZJ330M35V6.3X6.1NLF	33		0.12	0.26	300	2,000	
NAZJ470M35V6.3X6.1NLF	47		0.12	0.26	300	2,000	
NAZJ680M35V6.3X8NLF	68		0.12	0.16	600	2,000	

*Denotes Lower Reflow Temperature Rated, Lower Cost Alternative



STANDARD VALUES, CASE SIZES AND SPECIFICATIONS

NIC Part Number	Cap. (μF)	W.V. (Vdc)	Dissipation Factor (Tan δ)	Max. ESR (Ω) 100KHz, +20°C	Max. Ripple Current (mA) +105°C, 100KHz	Load Life Hours @ +105°C
NAZJ101M35V6.3X8NLBF	100	35	0.12	0.16	600	2,000
NAZJ101M35V8X10.5NLBF	100		0.12	0.08	850	2,000
NAZJ151M35V8X10.5NLBF	150		0.12	0.08	850	2,000
NAZJ221M35V8X10.5NLBF	220		0.12	0.08	850	2,000
NAZJ331M35V10X10.5NLBF	330		0.12	0.06	1190	2,000
NAZJ391M35V10X10.5NLBF	390		0.12	0.08	850	2,000
NAZJ471M35V10X14NLBF	470		0.12	0.06	1190	2,000
NAZJ101M50V8X10.5NLBF	100	50	0.10	0.18	670	2,000
NAZJ221M50V10X10.5NLBF	220		0.10	0.12	900	2,000
NAZJ331M50V10X14NLBF	330		0.10	0.10	900	2,000

*Denotes Lower Reflow Temperature Rated, Lower Cost Alternative

RIPPLE CURRENT FREQUENCY CORRECTION FACTOR (STANDARD)

Frequency	120Hz	1KHz	10KHz	100KHz ~
10 ~ 470μF	0.65	0.85	0.95	1.00
560 ~ 1800μF	0.75	0.90	0.95	1.00

RIPPLE CURRENT FREQUENCY CORRECTION FACTOR (ALTERNATIVE PART)

Frequency	120Hz	1KHz	10KHz	100KHz ~
100 ~ 150μF	0.50	0.80	0.95	1.00
220 ~ 1800μF	0.60	0.85	0.95	1.00

PEAK REFLOW TEMPERATURE, DURATION AND NUMBER OF REFLOW PASSES ALLOWED

Diameter	Reflow Code	Peak Temperature	Duration	Time above 200°C	Time above 217°C	Time above 230°C	Number of Reflow Passes
4 ~ 6.3mm φ	N	+260°C	Time ≥ 250°C 5 sec.	70 sec.	40 sec.	30 sec.	2
	N	+255°C	Time ≥ 250°C 10 sec.	70 sec.	40 sec.	30 sec.	2
8 ~ 10mm φ (see note 1)	N	+260°C	Time ≥ 250°C 5 sec.	70 sec.	40 sec.	30 sec.	1 only
	N	+245°C	Time ≥ 240°C 10 sec.	70 sec.	40 sec.	30 sec.	2

1. Only one (1) reflow pass is allowed for 8mm and 10mm diameter parts if the peak reflow temperature is +260°C.
2. In situations where two reflow passes is allowed the second reflow shall be at least one hour after natural cool to room temperature has occurred.

RECOMMENDED LAND PATTERN DIMENSIONS (mm)

Case Size	a	b	c
4x6.1	1.0	2.6	1.6
5x6.1	1.5	3.0	1.6
6x3x6.1 6.3x8	1.8	3.5	1.8
8x6.5	2.2	4.5	2.2
8x10.5	2.8	4.1	2.2
10x10.5	4.3	4.4	2.5
10x14			

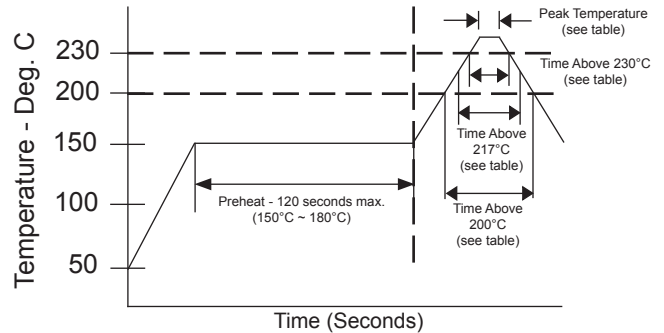
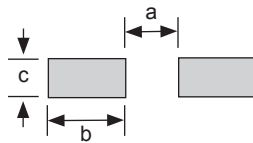

Review & Compare Reflow Soldering Heat Limits
V-chip SMT Aluminum Electrolytic Capacitors
www.niccomp.com/RSL

PRECAUTIONS

Please review the notes on correct use, safety and precautions found at www.niccomp.com/precautions
If in doubt or uncertainty, please review your specific application - process details with NIC's technical support personnel: tpmg@niccomp.com



WIDE TERMINATION (WT) DIM. (mm)

Case Size	Dφ ± 0.5	L max.	A, B ± 0.2	C max.	P ref.	I ref.	W	R ± 0.2	T ± 0.2
8x6.5	8.0	6.8	8.3	9.5	(2.2)	3.4	0.6 ~ 0.8	0.7	1.7
8x10.5	8.0	11.2	8.3	10.0	(3.1)	3.4	0.7 ~ 1.4	0.7	1.3
10x10.5	10.0	11.2	10.3	12.0	(4.6)	3.5	1.0 ~ 1.4	0.7	1.3
10x14	10.0	14.5	10.3	12.0	(4.6)	3.5	1.0 ~ 1.4	0.7	1.3

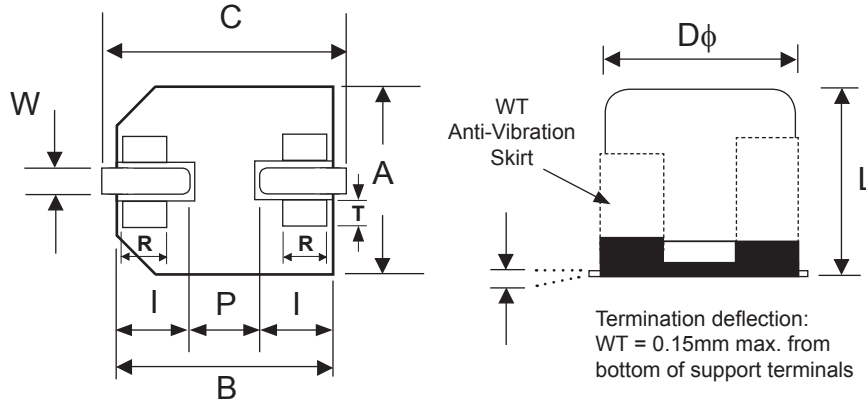

WT LAND PATTERN DIM. (mm)

Case Size	a	b	c
8x6.5	1.8	4.2	5.0
8x10.5	2.5	4.5	4.7
10x10.5	3.8	4.8	4.7
10x14	3.8	4.8	4.7

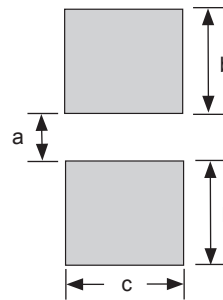

W (Wide Terminations) Anti-Vibration Test	
Test Method	Direction: X, Y, Z axis Frequency & Duration: 5 to 2000Hz reciprocation for 20 minutes, 2 hours each direction Peak to Peak Amplitude: 5mm Peak Acceleration: 30G Sweep Type: Log
Δ Capacitance	Within ± 10% of initial value
Tangent of Loss	≤ Specified value
Leakage Current	≤ Specified value

CARRIER TAPE

Case Size	A ±0.3	B ±0.3	C ±0.3	D ±0.1	P ±0.1	T ±0.2
4 x 6.1	4.7	4.7	12.0	5.5	8.0	6.2
5 x 6.1	5.7	5.7	12.0	5.5	12.0	6.4
6.3 x 6.1	7.0	7.0	16.0	7.5	12.0	6.4
6.3 x 8	7.0	7.0	16.0	7.5	12.0	8.4
8 x 6.5	8.7	8.7	16.0	7.5	12.0	6.8
8 X 10.5	8.7	8.7	24.0	11.5	16.0	11.1
10 x 10.5	10.7	10.7	24.0	11.5	16.0	11.2
10 x 14	10.7	10.7	24.0	11.5	16.0	14.6

B suffix 330mm (13") CARDBOARD REEL
LB suffix 380mm (15") CARDBOARD REEL
 (See page 6 for plastic reel dimensions)

Case Size	W ±1.0	Quantity Per Reel	
		13" Reel	15" Reel
4 x 6.1	14.0	1,200 pcs	-
5 x 6.1	14.0	800 pcs	-
6.3 x 6.1	18.0	-	1,000 pcs
6.3 x 8	18.0	-	900 pcs
8 x 6.5	18.0	800 pcs	-
8 X 10.5	26.0	-	500 pcs
10 x 10.5	26.0	-	500 pcs
10 x 14	26.0	-	400 pcs

TAPING SPECIFICATIONS (mm)

- Both Leader and Trailer tape: Minimum 40mm (1.57") empty carrier tape pockets.
- Leader tape: Approximately 20cm of cover tape at leader.
- Connection: Maximum 3 connections (slices) per reel.

CARRIER

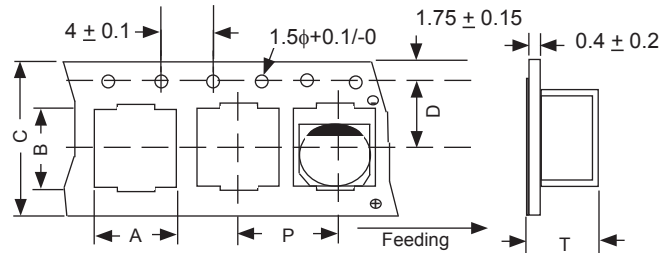

CARDBOARD REEL

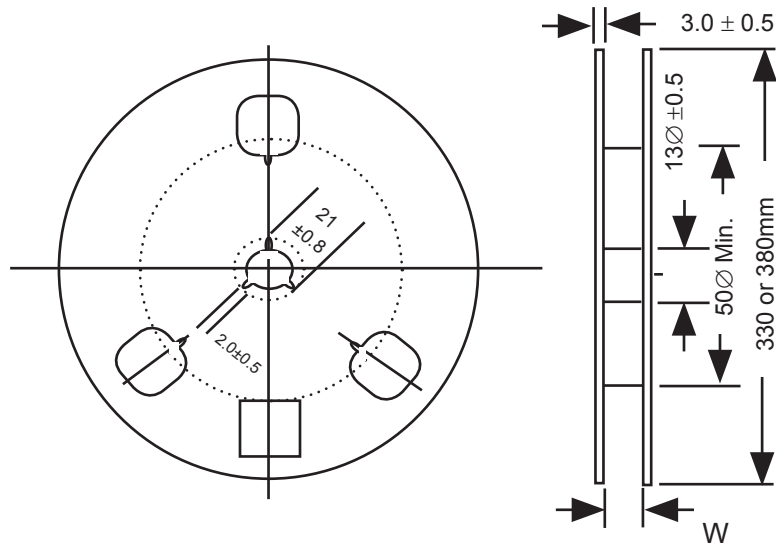

Optional V-Chip 13" (330mm) Plastic Reels (BP suffix)

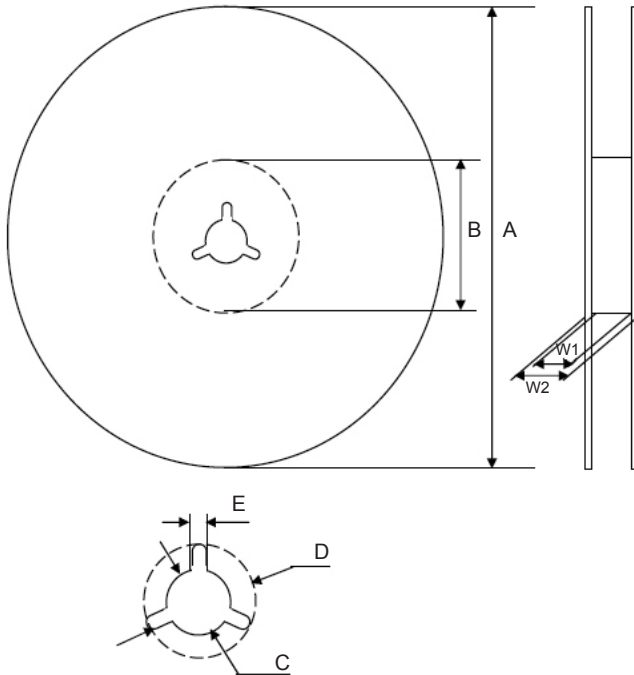

Dimensions (mm)

Case Size	Tape Width	W1	W2
4x6.1, 5x6.1	12.0	12.4 ~ 14.4	15.5 ~ 20.0
8x6.5	16.0	16.4 ~ 18.4	19.5 ~ 24.0

Case Size	Tape Width	A	B	C	D	E
4x6.1, 5x6.1	12.0	$\phi 330$	$\phi 50 \sim 105$	$\phi 13$	$\phi 21$	2.0
8x6.5	16.0	± 2.0		± 0.5	± 1.0	± 0.5

Color
Black or Blue

Optional V-Chip 15" (380mm) Plastic Reels (LBP suffix)

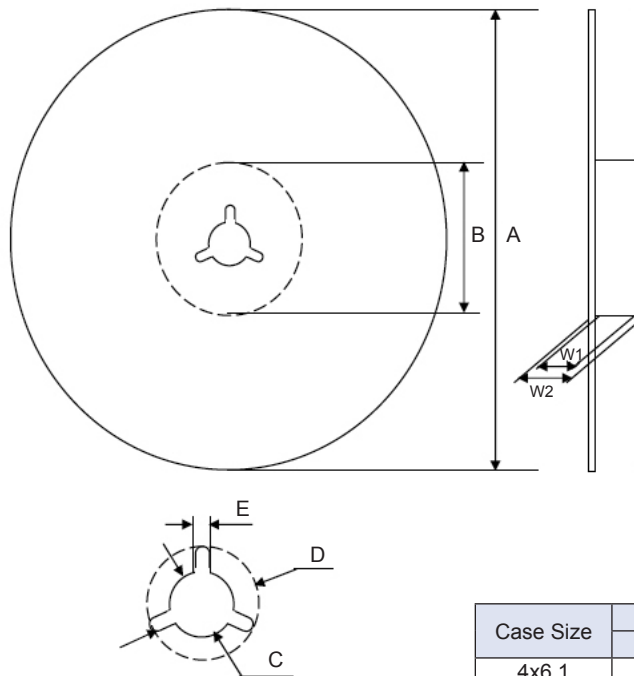

Dimensions (mm)

Case Size	Tape Width	W1	W2
6.3x6.1, 6.3x8	16.0	16.5 ~ 18.0	19.5 ~ 24.0
8x10.5, 10x10.5, 10x14	24.0	24.5 ~ 26.0	27.5 ~ 32.0

Case Size	Tape Width	A	B	C	D	E
6.3x6.1, 6.3x8	16.0	$\phi 380$	$\phi 80 \sim 105$	$\phi 13$	$\phi 21$	2.0
8x10.5, 10x10.5, 10x14	24.0	± 2		± 0.5	± 1.0	± 0.5

Color
Black or Blue

Case Size	Quantity Per Reel	
	13" Reel	15" Reel
4x6.1	1,200 pcs	-
5x6.1	800 pcs	-
6.3x6.1	-	1,000 pcs
6.3x8	-	900 pcs
8x6.5	800 pcs	-
8x10.5	-	500 pcs
10x10.5	-	500 pcs
10x14	-	400 pcs