

Single Cell Li-ion Battery Charger with Power Path Management and Full USB Compliance

Features

- Charge Voltage Regulation Accuracy: $\pm 0.5\%$ (0°C to 50°C)
- Charge Current Accuracy: $\pm 5\%$
- Maximum 28V Input Voltage Rating with Over-Voltage Protection
- Minimum -5V Input Voltage Protection
- Complete Charge Process with Pre-Charge, Fast Charge and Constant Voltage Regulation
- Programmable Charge Parameters Through I²C Compatible Interface
- Programmable Charge Termination and Autonomous Recharge
- Wide Range of Fast Charge Current: 2mA~512mA
- Strong and Robust Protection: V_{IN} OVP, Battery OVP, OCP, Reverse Leakage Protection, Short Protection, Thermal Protection, PCB Over Temperature Protection
- BATFET Control to Support Shipping Mode
- Pull Down INT And VIN Pulse Reset System Function
- Fully Integrated Power Path Management
- Ultra-low Battery Leakage Current to Support Shipping Mode
- WLCSP 1.4mm×1.4mm×0.63mm-9B, 0.5mm Pitch Package
- 7-bit slave address (A7~A1) is 1001001 binary(0x49H)
- IEC62368-1 Approved-File No.BE-37454

Applications

- Smart Handheld Devices
- Wearable Devices
- Smart Watches
- Fitness Accessories

General Description

The AW32012A is a highly-integrated Li-Ion/Li-Polymer battery linear charger with system power path management. The charge process of AW32012A includes: Pre-Charge, Fast Charge and Constant Voltage Regulation. The charge parameters and operating modes are programmable through I²C interface. The charge process runs automatically and recharging occurs when the battery voltage drops below V_{BAT_REG-V_{RCH}} after the charge done status.

The AW32012A is targeted at space limited portable applications. The chip can take input power from either an AC adaptor or a USB port to supply the system load and charge the battery. Meanwhile, the chip provides system short circuit protection function by limiting the current from the input to the system and the battery to the system. These features are effective to protect the battery or chip from damage. The parameters of input current limit, the discharge current limit and safety timer can be programmed by the I²C interface. Additionally, input over voltage protection, input under voltage lockout and input headroom voltage are integrated for good input source detection.

AW32012A separates the charging route from the system power supply to fulfill the power management function. The system power supply is at first priority with no dependency on battery existence. Once a bad power-limited adapter appears at the input, AW32012A would reduce the charging current firstly. If the system load is still too heavy for input source, AW32012A will reduce the input-system current to prevent the input source from being pulled down. Under this circumstance, if the system voltage drops 30mV below the battery voltage, the battery to system supply route will be fully turned on to power the system load, which is supplement mode.

Typical Application Circuit

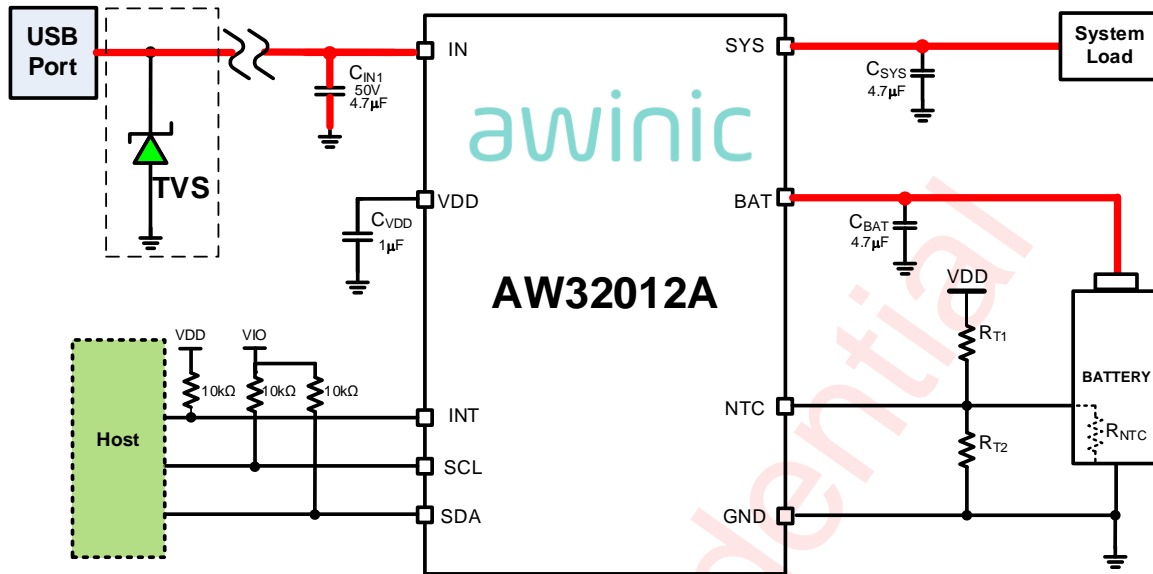

Figure 1 Typical Application Circuit of AW32012A

All trademarks are the property of their respective owners.

Pin Configuration and Top Mark

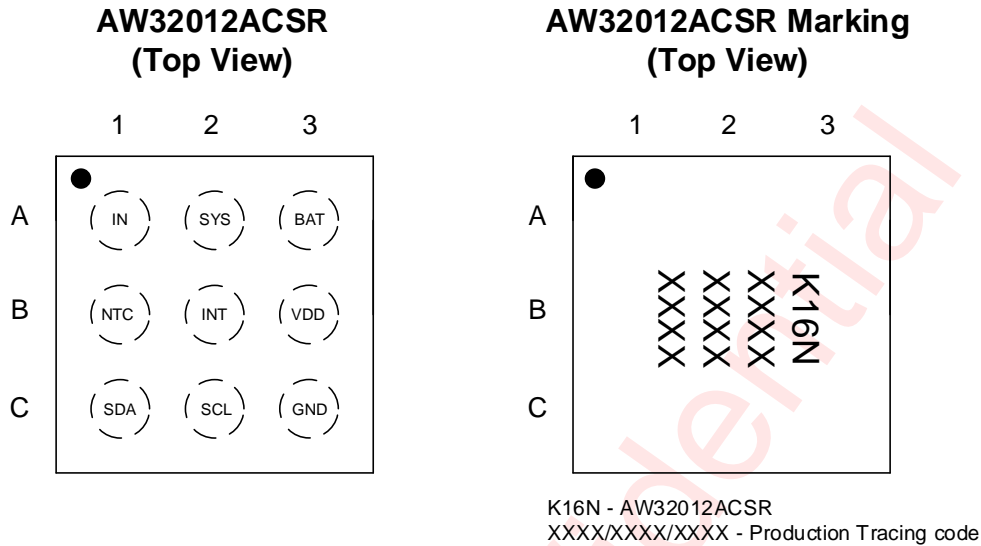

Figure 2 Pin Configuration and Top Mark

Pin Definition

Pin No.	Pin Name	Description
A1	IN	Input power pin. Bypass with a 4.7μF capacitor to GND.
A2	SYS	System power supply pin. Bypass with a 4.7μF capacitor to GND.
A3	BAT	Battery pin. Bypass with a 4.7μF capacitor to GND.
B1	NTC	Temperature sense input. Connect a negative temperature coefficient thermistor. Program the hot and cold temperature window with resistor dividers from VDD to GND, and NTC is the middle node. Pull NTC to VDD if NTC function is not used. If NTC function is unused or disable, it is suggested to disable the NTC function and tie the NTC port to VDD for decreasing leakage current of battery.
B2	INT	Interrupt output. The INT pin can send charge status and fault interrupt to the host. This pin is also used to disconnect the system from battery, and awake the chip from shipping mode. If INT is unused, it is suggested to tie INT to VDD by resistor.
B3	VDD	Internal power supply pin. Bypass with a 1μF capacitor to GND. No external load is allowed.
C1	SDA	I ² C Interface serial data.
C2	SCL	I ² C Interface clock.
C3	GND	Ground.

Ordering Information

Part Number	Temperature	Package	Marking	Moisture Sensitivity Level	Environmental Information	Delivery Form
AW32012ACSR	-40°C~85°C	WLCSP 1.4mmx1.4mm-9B	K16N	MSL1	ROHS+HF	3000 units/ Tape and Reel

Awinic Confidential

Absolute Maximum Ratings^(NOTE1)

PARAMETERS		MIN	MAX	UNIT
Input voltage range V_{IN} (with respect to GND)	IN	-5	28	V
NTC voltage range V_{NTC} (with respect to GND)	NTC	-0.3	$V_{VDD}+0.3$	V
Other pins voltage range (with respect to GND)	SYS, BAT, INT, VDD, SCL, SDA	-0.3	6	V
Operating free-air temperature range		-40	85	°C
Operating junction temperature T_J		-40	150	°C
Storage temperature T_{STG}		-65	150	°C
Lead temperature (Soldering 10 seconds)			260	°C

NOTE1: Conditions out of those ranges listed in "absolute maximum ratings" may cause permanent damages to the device. In spite of the limits above, functional operation conditions of the device should be within the ranges listed in "recommended operating conditions". Exposure to absolute-maximum-rated conditions for prolonged periods may affect device reliability.

ESD Rating and Latch Up

PARAMETERS	VALUE	UNIT
HBM (Human Body Model) ^(NOTE 2)	±2	kV
CDM ^(NOTE 3)	±1.5	kV
Latch-Up ^(NOTE 4)	+IT: 200 -IT: -200	mA

NOTE2: The human body model is a 100pF capacitor discharged through a 1.5kΩ resistor into each pin. Test method: ESDA/JEDEC JS-001-2017

NOTE3: Test method: ESDA/JEDEC JS-002-2018

NOTE4: Test method: JESD78E

Recommended Operating Conditions

PARAMETERS	MIN	NORM	MAX	UNIT
Supply voltage range V_{IN}	4		7.5	V
Supply current I_{IN}			550	mA
Discharge current I_{BAT}			3.2	A
Charge current I_{CHG}	2		512	mA
Battery regulated voltage V_{BAT_REG}	3.6		4.545	V
Operating junction temperature T_J	-40		125	°C

Thermal Information

PARAMETERS	VALUE	UNIT
Junction-to-ambient thermal resistance θ_{JA}	90.61	°C/W

Electrical Characteristics

$V_{IN}=5V$, $V_{BAT}=3.5V$, $T_J=25^{\circ}C$ for typical values (unless otherwise noted).

PARAMETER		TEST CONDITIONS	MIN	TYP	MAX	UNIT
INPUT SOURCE AND BATTERY PROTECTION						
V_{IN_UVLO}	UVLO threshold voltage, entry UVLO	V_{IN} falling	3.5	3.6	3.7	V
	Hysteresis for UVLO	V_{IN} rising		300		mV
T_{DGL_UVLO}	Exit Deglitch time for V_{IN_UVLO}	Exits UVLO		30		ms
V_{IN_OVP}	VIN OVP threshold voltage	REG0DH[5]=0, V_{IN} rising	5.85	6	6.15	V
		REG0DH[5]=1, V_{IN} rising		7.5		V
	VIN OVP hysteresis	V_{IN} falling from above V_{IN_OVP}		350		mV
T_{DGL_OVP}	Exit deglitch time for V_{IN_OVP}	Exits V_{IN} OVP		30		ms
V_{BAT}	BAT input voltage				4.6	V
V_{BAT_UVLO}	UVLO threshold voltage for BAT voltage, V_{BAT} falling, entry UVLO	REG01H[2:0]=000	2.3	2.43	2.53	V
		REG01H[2:0]=100	2.64	2.76	2.88	V
		REG01H[2:0]=111	2.88	3.03	3.13	V
	Hysteresis voltage	$V_{BAT_UVLO}=2.76V$		220		mV
V_{HDM}	Input vs. battery voltage headroom threshold	V_{IN} rising	80	130	180	mV
	Input vs. battery voltage headroom threshold hysteresis	V_{IN} falling		60		mV
CHARGE PROCESS						
V_{BAT_PRE}	Pre-charge to fast charge threshold	REG04H[1]=1, V_{BAT} rising	2.9	3.0	3.1	V
		REG04H[1]=0, V_{BAT} rising	2.7	2.8	2.9	V
	Fast charge to pre-charge threshold	V_{BAT} falling		200		mV
V_{BAT_REG}	Battery charge voltage regulation voltage	REG04H[7:2]=000000, $V_{BAT_REG}=3.6V$	3.585	3.600	3.615	V
		REG04H[7:2]=101000, $V_{BAT_REG}=4.2V$	4.180	4.200	4.220	V
		REG04H[7:2]=110100, $V_{BAT_REG}=4.38V$	4.360	4.380	4.400	V
		REG04H[7:2]=111110, $V_{BAT_REG}=4.53V$	4.507	4.530	4.553	V
V_{RECH}	Recharge threshold voltage	REG0DH[0]=1, REG04H[0]=0, $V_{BAT_REG}=4.2V$, below V_{BAT_REG}		50		mV
		REG0DH[0]=0, REG04H[0]=0, $V_{BAT_REG}=4.2V$, below V_{BAT_REG}	45	100	155	mV
		REG0DH[0]=1, REG04H[0]=1, $V_{BAT_REG}=4.2V$, below V_{BAT_REG}				
		REG0DH[0]=0, REG04H[0]=1, $V_{BAT_REG}=4.2V$, below V_{BAT_REG}	145	200	255	mV

PARAMETER		TEST CONDITIONS	MIN	TYP	MAX	UNIT
	Deglitch time for V_{RCH}	V_{BAT} falling below V_{RECH} after charge termination		130		ms
V_{BAT_OVP}	Battery OVP threshold voltage	V_{BAT} threshold over V_{BAT_REG} to turn off charger during charging		120		mV
	V_{BAT_OVP} hysteresis			50		mV

Awinic Confidential

Electrical Characteristics (Continued)V_{IN}=5V, V_{BAT}=3.5V, T_J=25°C for typical values (unless otherwise noted).

PARAMETER	TEST CONDITIONS	MIN	TYP	MAX	UNIT	
POWER PATH MANAGEMENT						
V _{SYS_REG}	Regulated system output voltage	V _{IN} =5.0V, REG07H[3:0]=0000, R _{SYS} =100Ω, I _{CHG} =0A, V _{SYS_REG} =4.2V	4.11	4.20	4.29	V
		V _{IN} =5.0V, REG07H[3:0]=1000, R _{SYS} =100Ω, I _{CHG} =0A, V _{SYS_REG} =4.6V	4.51	4.60	4.69	V
		V _{IN} =5.3V, REG07H[3:0]=1111, R _{SYS} =100Ω, I _{CHG} =0A, V _{SYS_REG} =4.95V	4.85	4.95	5.05	V
I _{IN_LIM}	Input current limit	REG00H[3:0]=0000, I _{IN_LIM} =50mA	30	47	60	mA
		REG00H[3:0]=0011, I _{IN_LIM} =140mA	112	138	160	mA
		REG00H[3:0]=1000, I _{IN_LIM} =290mA	270	296	320	mA
		REG00H[3:0]=1111, I _{IN_LIM} =500mA	465	500	535	mA
V _{IN_DPM}	Dynamic input power management clamp voltage	REG00H[7:4]=0000, V _{IN_DPM} =3.88V	3.68	3.88	4.18	V
		REG00H[7:4]=1000, V _{IN_DPM} =4.52V	4.32	4.52	4.82	V
		REG00H[7:4]=1111, V _{IN_DPM} =5.08V	4.88	5.08	5.35	V
R _{ON_Q1}	IN to SYS switches on resistance	V _{IN_DPM} =3.88V, V _{IN} =4.5V, I _{SYS} =100mA	290	330	370	mΩ
R _{ON_Q2}	BAT to SYS switch on resistance	V _{IN} <2V, V _{BAT} =3.5V, I _{SYS} =100mA	95	115	135	mΩ
I _{IN_Q}	Input quiescent current (not include the current from external NTC resistor)	V _{IN} =5V, EN_HIZ=0, CEB=0, (charge enable) , I _{CHG} =0, I _{SYS} =0	0.35	0.6	0.85	mA
		V _{IN} =5V, EN_HIZ=0, CEB=1, (charge disabled) , I _{CHG} =0, I _{SYS} =0	0.3	0.45	0.6	mA
I _{BAT_Q}	Battery quiescent current (not include the current from external NTC resistor)	V _{IN} =5V, CEB=0, charge done, I _{CHG} =0, I _{SYS} =0	20	26	32	μA
		V _{IN} =0, CEB=1, V _{BAT} =4.35V, DIS_PCB_OTP=1, I _{SYS} =0		8	9	μA
		V _{IN} =0, CEB=1, V _{BAT} =4.35V, DIS_PCB_OTP=0, I _{SYS} =0		18.5	20	μA
		V _{IN} =0, CEB=1, V _{BAT} =4.35V, DIS_PCB_OTP=0, I _{SYS} =0, enable watchdog		23	25.5	μA
		V _{BAT} =4.5V, V _{IN} =0V/Ground, Switch mode=1		2.4		μA
		V _{BAT} =4.5V, V _{IN} =V _{SYS} =0, FET_DIS=1, shipping mode		0.05	1	μA
I _{SYS-BAT_LKG}	SYS reverse to BAT switch leakage	V _{SYS} =4.60V, V _{IN} =5V, V _{BAT} =0, CEB=1, EN_HIZ=1, charge disabled			1	μA
I _{DSCHG}	BAT FET discharge current limit	REG03H[7:4]=0100, I _{DSCHG} =1000mA	900	1000	1100	mA
		REG03H[7:4]=1001, I _{DSCHG} =2000mA		2000		mA
V _{FWD}	Ideal diode forward voltage in supplement mode	50mA discharge current		30		mV

Electrical Characteristics (Continued) $V_{IN}=5V$, $V_{BAT}=3.5V$, $T_J=25^\circ C$ for typical values (unless otherwise noted)

PARAMETER	TEST CONDITIONS	MIN	TYP	MAX	UNIT	
CHARGE CURRENT						
I_{CHG}	Output charge regulation current programmable range	$V_{BAT_PRE} < V_{BAT} < V_{BAT_REG}$, REG0BH[7]=1, $I_{CHG}=2mA$	1.5	2	2.5	mA
		$V_{BAT_PRE} < V_{BAT} < V_{BAT_REG}$, REG0BH[7]=0, $I_{CHG}=8mA$	7	8	9	mA
		$V_{BAT_PRE} < V_{BAT} < V_{BAT_REG}$, REG0BH[7]=0, $I_{CHG}=96mA$	89	96	103	mA
		$V_{BAT_PRE} < V_{BAT} < V_{BAT_REG}$, REG0BH[7]=0, $I_{CHG}=264mA$	251	264	277	mA
		$V_{BAT_PRE} < V_{BAT} < V_{BAT_REG}$, REG0BH[7]=0, $I_{CHG}=456mA$	434	456	478	mA
	Charge Current Regulation Accuracy	$V_{BAT}=3.8V$, $I_{CHG}=2mA$	-25		25	%
		$V_{BAT}=3.8V$, $4mA < I_{CHG} \leq 12mA$	-20		20	%
		$V_{BAT}=3.8V$, $12mA < I_{CHG} < 264mA$	-7		7	%
		$V_{BAT}=3.8V$, $I_{CHG} \geq 264mA$	-5		5	%
I_{PRE}	Pre-charge current programmable range, $I_{PRE}=I_{TERM}$	$V_{BAT} < 3.0V$	1		31	mA
I_{TERM}	Termination charge current threshold, programmable	REG03H[3:0]=0000, $I_{TERM}=1mA$	0.7	1	1.3	mA
		REG03H[3:0]=0001, $I_{TERM}=3mA$	2.4	3	3.6	mA
		REG03H[3:0]=0101, $I_{TERM}=11mA$	9	11	13	mA
		REG03H[3:0]=1111, $I_{TERM}=31mA$	28	31	34	mA
	The flag of termination charge current	REG0DH[1]=1,REG11H[4]=1		80		mA
T_{TERM}	Termination deglitch time	$I_{CHG} < I_{TERM}$, REG0CH[6]=0		3.2		s
I_{DBAT}	Battery detection current before charge done (sink current)	Begins after termination detected and $V_{BAT} < V_{BAT_REG}$		0.5		mA
T_{DBAT}	Battery detection time			262		ms
INT						
V_{OL_INT}	Low-level output saturation voltage, INT pin	$I_O=5mA$, sink current			0.4	V
I_{LKG_INT}	High-level leakage current for INT	INT is in High-impedance status, $V_{INT}=5V$			1	μA
T_{RST_DGL}	INT pulled low time to reset V_{SYS}	V_{INT} low(default setting)		16		s
I²C BUS LOGIC LEVELS AND TIMING CHARACTERISTICS						
V_{OL}	Output low threshold level	$I_O=5mA$, sink current			0.4	V
V_{IL}	Input low threshold level	$V_{pull_up}=1.8V$, SDA, SCL and INT			0.4	V

PARAMETER		TEST CONDITIONS	MIN	TYP	MAX	UNIT
V _{IH}	Input high threshold level	V _{pull_up} =1.8V, SDA, SCL and INT	1.3			V
I _{BIAS}	Input bias current	V _{pull_up} =1.8V, SDA and SCL			1	μA
THERMAL PROTECTION						
T _{J_REG}	Junction temperature regulation	Junction temperature rising		120		°C
T _{OTP}	Overheating shutdown protection temperature	Junction temperature rising		150		°C
	Thermal hysteresis for T _{OTP}	Junction temperature falling		20		°C
I _{NTC}	NTC pin output current	CEB=0, NTC=3V	65	70	75	μA
V _{COLD}	NTC cold temp rising threshold	Percentage of VDD	62	64	66	%
	Hysteresis voltage			70		mV
V _{HOT}	NTC hot temp falling threshold	Percentage of VDD	34	36	38	%
	Hysteresis voltage			70		mV
V _{HOT_PCB}	NTC hot temp falling threshold for PCB OTP	Percentage of VDD	34	36	38	%
	Hysteresis voltage			70		mV
SHIPPING MODE EXIT TIME						
T _{EXIT_SHIPMODE}	VBUS Plug in (not include Exit Deglitch time for V _{IN_UVLO})	REG0BH[0]=0		2		s
		REG0BH[0]=1		100		ms
	Put down INT PIN (not include Exit Deglitch time for V _{IN_UVLO})	REG0DH[2]=0		2		s
		REG0DH[2]=1		100		ms
CLOCK FREQUENCY AND WATCHDOG TIMER						
F _{CLK}	Clock frequency			125		KHz
t _{WDT}	Watchdog timer	REG05H[6:5]=11		160		s

Electrical Characteristics (Continued) $V_{IN}=5V$, $V_{BAT}=3.5V$, $T_J=25^\circ C$ for typical values (unless otherwise noted)**I²C INTERFACE TIMING**

SYMBOL	DESCRIPTION	MIN	TYP	MAX	UNIT
F_{SCL}	Interface Clock Frequency			400	kHz
$T_{DEGLITCH}$	Deglitch Time	SCL	83		ns
		SDA	115		ns
$t_{HD:STA}$	(Repeat-Start) Start Condition Hold Time	0.6			μs
t_{LOW}	Low Level Width of SCL	1.3			μs
t_{HIGH}	High Level Width of SCL	0.6			μs
$t_{SU:STA}$	(Repeat-Start) Start Condition Setup Time	0.6			μs
$t_{HD:DAT}$	Data Hold Time	0			μs
$t_{SU:DAT}$	Data Setup Time	0.1			μs
t_R	Rising Time of SDA and SCL			0.3	μs
t_F	Falling Time of SDA and SCL			0.3	μs
$t_{SU:STO}$	Stop Condition Setup Time	0.6			μs
t_{BUF}	Time Between Start and Stop Condition	1.3			μs

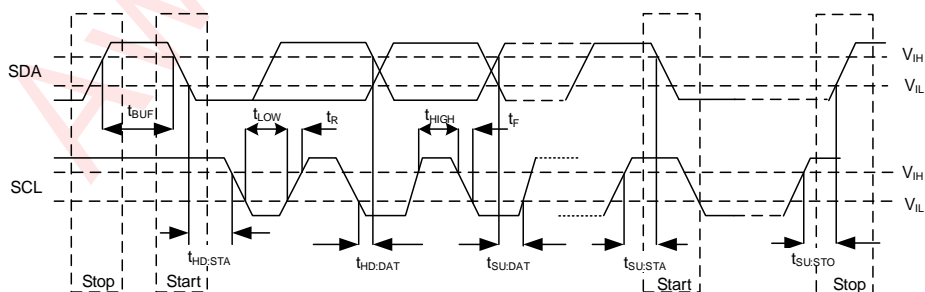
**Figure 3 I²C Interface Timing**

Typical Characteristics

$V_{IN}=5V$, $T_J=25^\circ C$, $I_{IN_LIM}=500mA$, $I_{CHG}=128mA$, $V_{IN_DPM}=4.6V$, unless other noted.

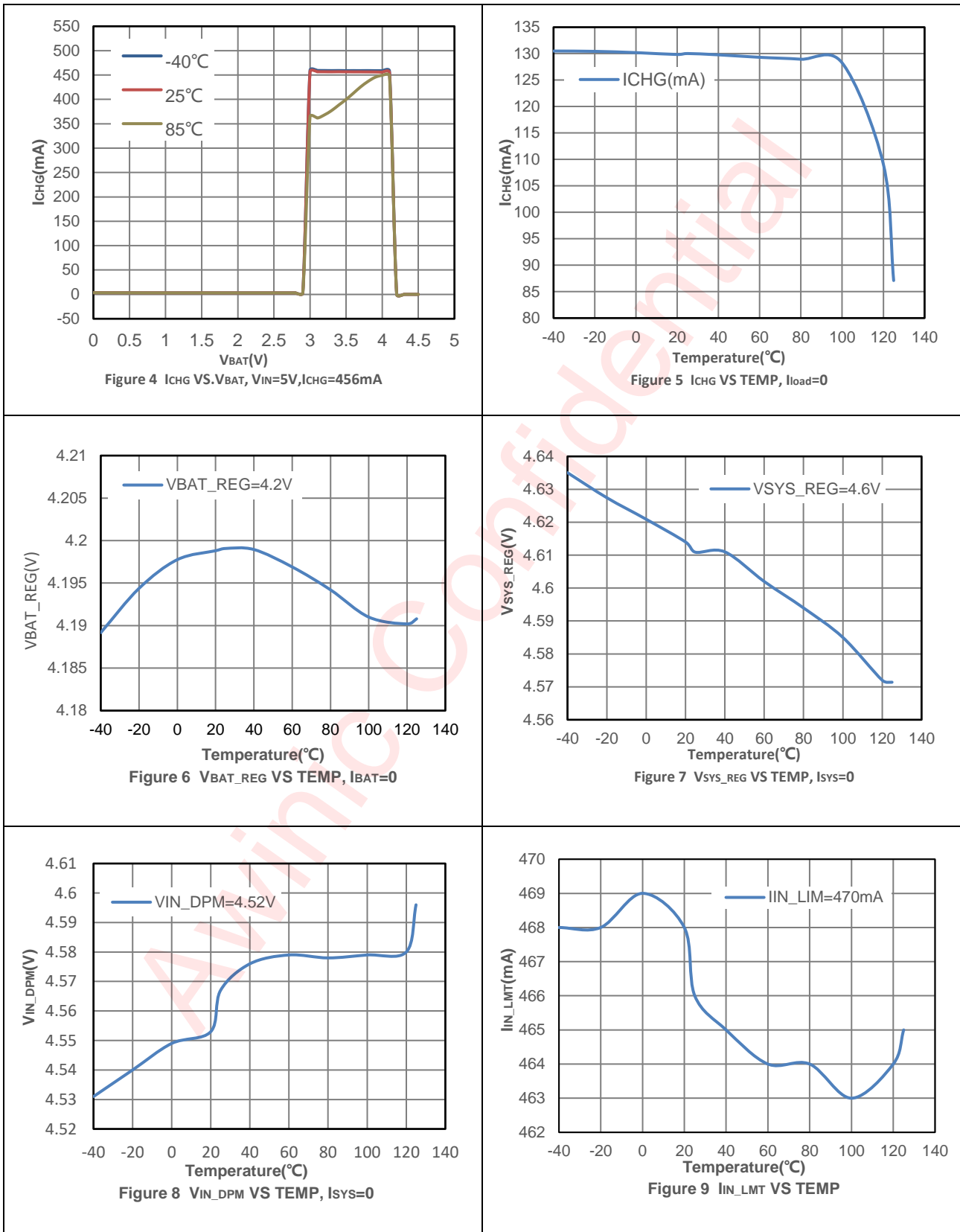

Typical Characteristics

$V_{IN}=5V$, $T_J=25^\circ C$, $I_{IN_LIM}=500mA$, $I_{CHG}=128mA$, $V_{IN_DPM}=4.6V$, unless other noted.

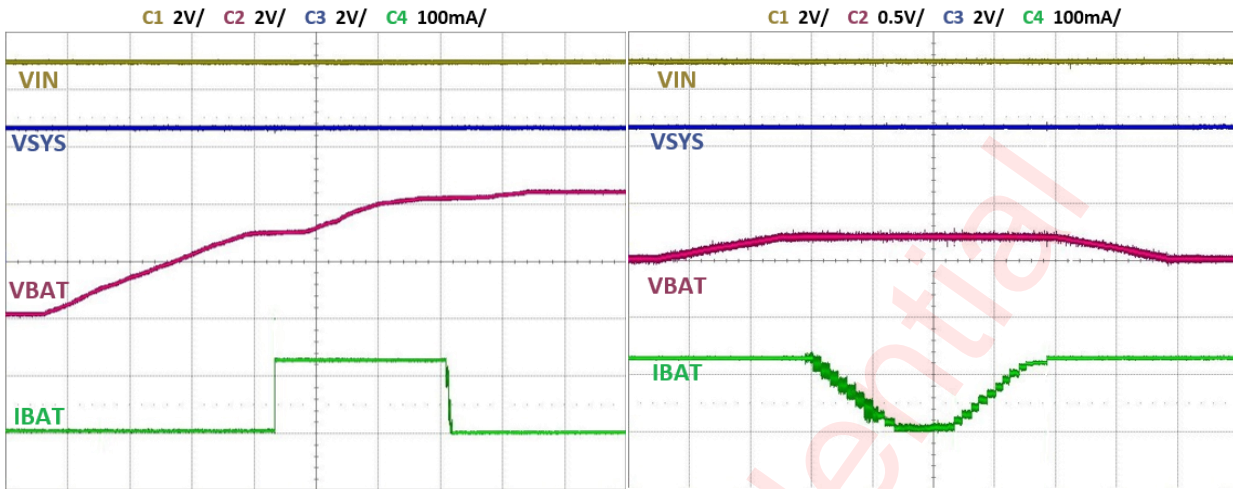

$I_{SYS}=0A$
Battery Charge Curve

$I_{SYS}=0A$
Auto-Recharge Curve

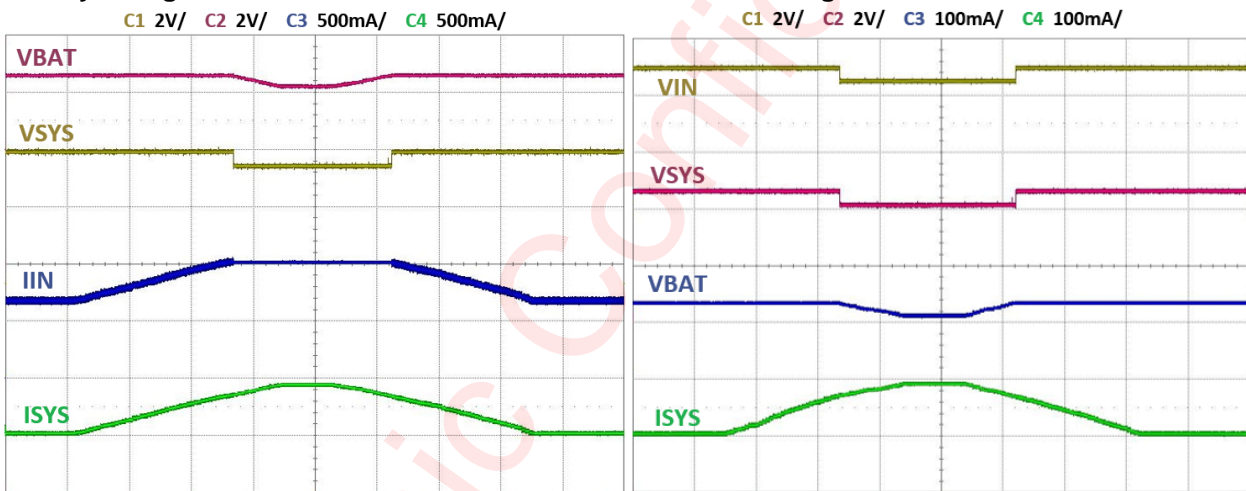

$V_{BAT}=3.7V$
Input Current Limit-Based PPM

$V_{IN}=5V/200mA$, $V_{BAT}=3.7V$
Input Voltage Regulation-Based PPM

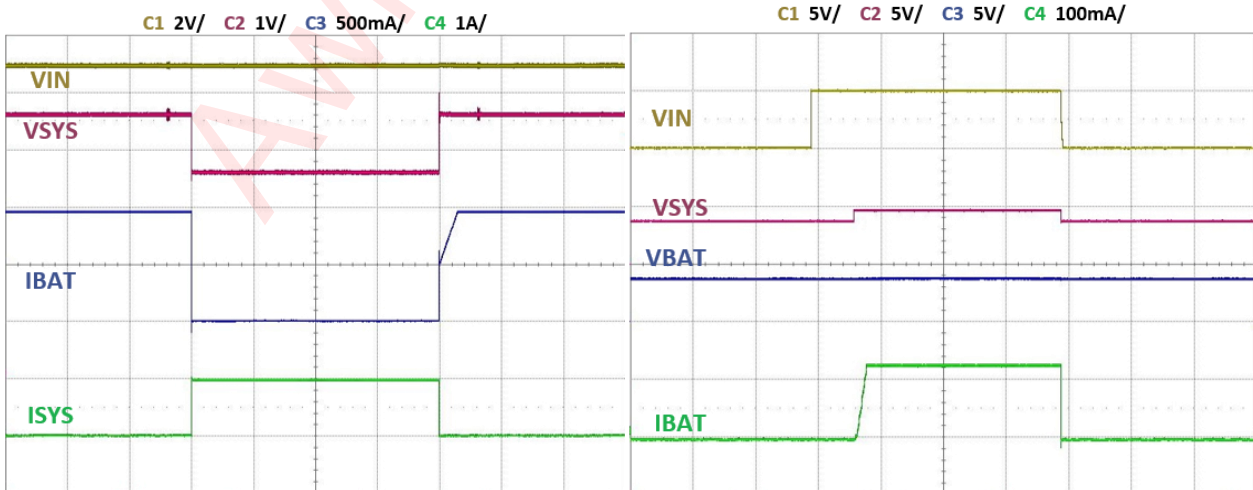

$V_{IN}=5V$, $V_{BAT}=3.7V$, $I_{CHG}=456mA$, $I_{SYS}=0A\sim 1A$
SYS Load Transient

$V_{BAT}=3.7V$, $I_{SYS}=0A$
Power On/Off

Typical Characteristics (Continued)

$V_{IN}=5V$, $T_J=25^{\circ}C$, $I_{IN_LIM}=500mA$, $I_{CHG}=128mA$, $V_{IN_DPM}=4.6V$, unless other noted.

C1 5V/ C2 5V/ C3 5V/ C4 100mA/

C1 5V/ C2 2V/ C3 5V/ C4 100mA/

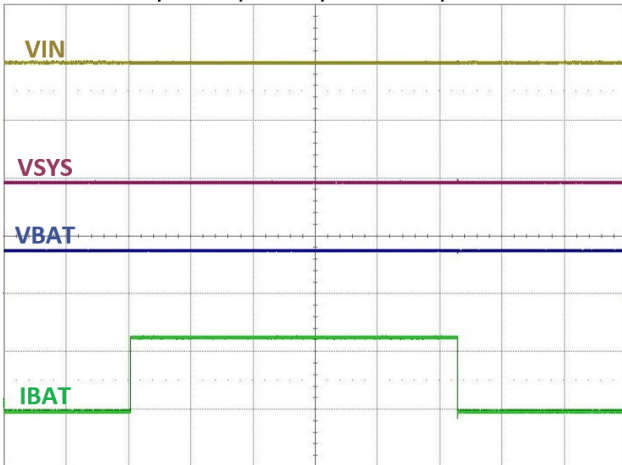

$V_{BAT}=3.7V$, $I_{SYS}=0A$
Charge Enable/Disable



$V_{BAT}=3.7V$, $I_{SYS}=0A$, PCB_OTP disabled
NTC Rising

C1 5V/ C2 2V/ C3 5V/ C4 100mA/

C1 2V/ C2 2V/ C3 2V/ C4 100mA/

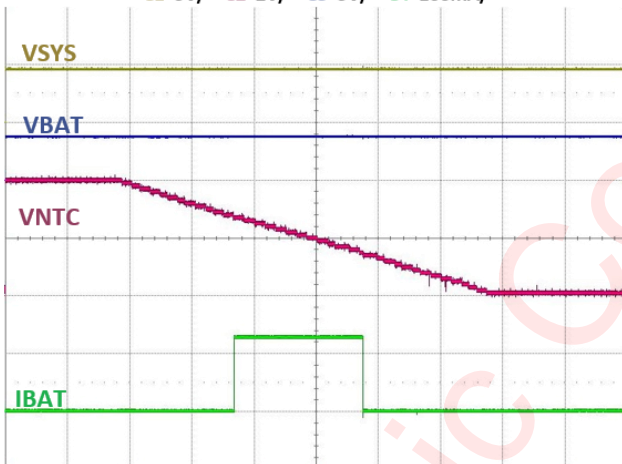

$V_{BAT}=3.7V$, $I_{SYS}=0A$, PCB_OTP disabled
NTC Falling

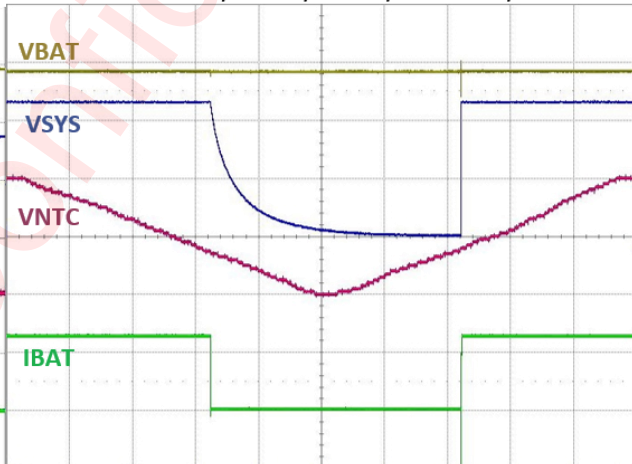

$V_{BAT}=3.7V$, $I_{SYS}=0A$
PCB_OTP @Charge mode

C1 2V/ C2 2V/ C3 2V/

C1 2V/ C2 2V/ C3 2V/ C4 100mA/

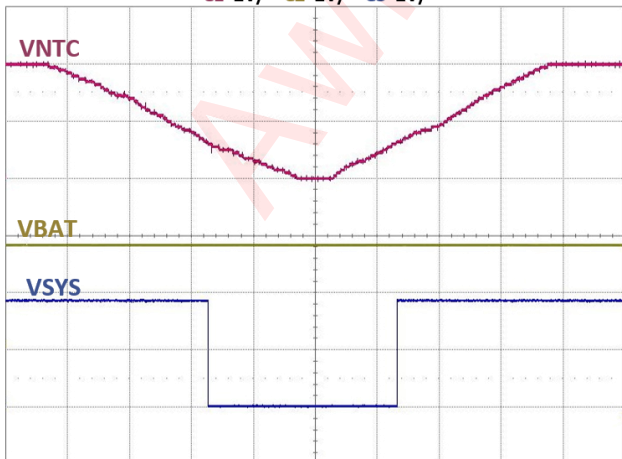

$V_{IN}=0V$, $V_{BAT}=3.7V$
PCB_OTP @Discharge mode

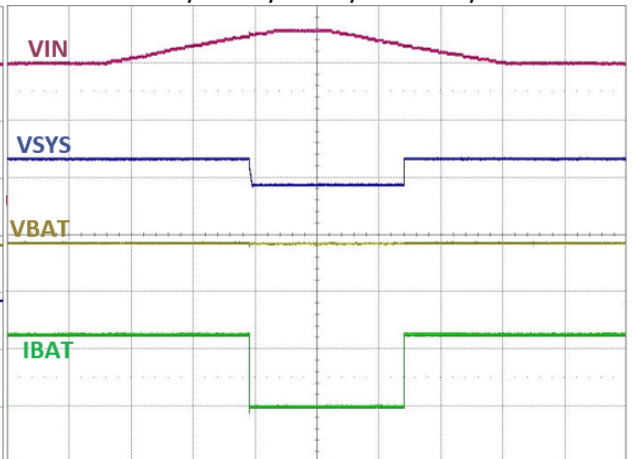

$V_{BAT}=3.7V$, $I_{SYS}=0A$
 V_{IN} OVP Operation

Functional Diagram

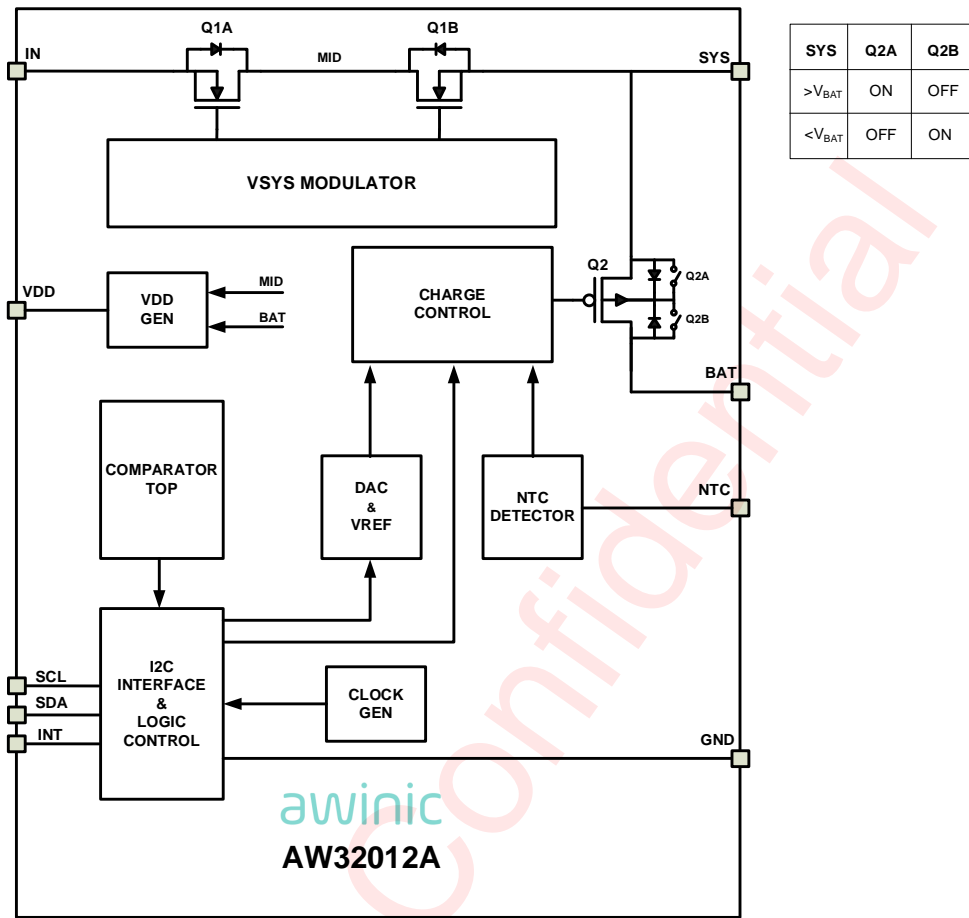

Figure 10 Functional Block Diagram

Detailed Functional Description

The AW32012A is a highly integrated linear battery charger with a complete power path management function (PPMF). The full-charge process of AW32012A not only includes pre-charge, constant-current fast charge (CC) and constant voltage (CV) regulation, but also charge termination, auto-recharge, etc. The PPMF can manage the input source to power the system load and charge the battery simultaneously. The system load has a higher priority than the charge current. When the input power is limited by input current or voltage, the charge current will decrease automatically.

Main Machine

AW32012A includes: START, Battery Discharge Mode(DISCHG), Battery Charge Mode(CHG), Only Power System Mode(OPSM) and Shipping Mode(SHIP), Figure 11 is shown the main state machine conversion.

- (1) Battery Discharge Mode: Only Battery to SYS Path is enabled.
- (2) Battery Charge Mode: IN to SYS path and SYS to Battery path are enabled.
- (3) Only Power System Mode: Only IN to SYS Path is enabled.
- (4) Shipping Mode: All paths are disabled, AW32012A enters into low power consumption state.

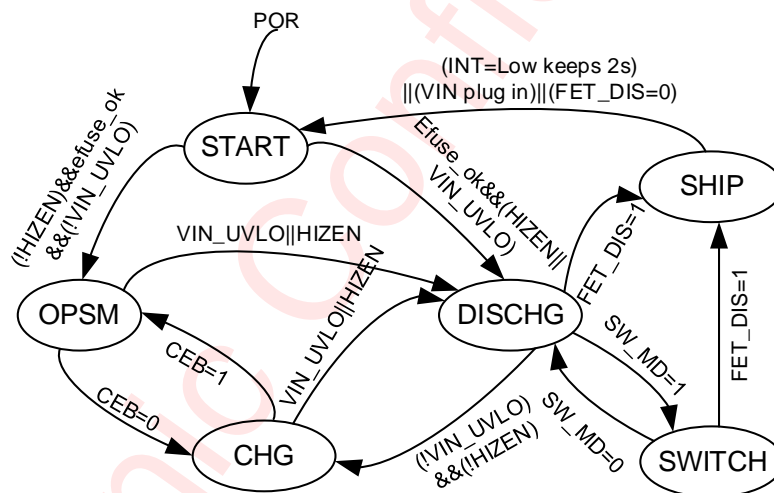

Figure 11 The main state machine conversion

The AW32012A integrates an input reverse-block FET (Q1A), a LDO FET (Q1B) between IN and SYS, and a BATFET (Q2) between SYS and BAT. When VBUS plugs in and CEB=1, the device works in OPSM mode that only IN and SYS path is enabled, the system is powered by VBUS. If CEB=0, the charge function is enabled and Q2 turn on, the status switches to Battery Charge mode(CHG). When the system load demand is over the input power capacity, the PPMF of AW32012A will reduce the charging current or use power from the battery to satisfy the system load. The charge current is limited to maintain the system power supply with higher priority all the time. Figure 15 shows the PPMF structure of the AW32012A, which is called Battery Supplement Mode too. Once the VBUS is unplugged, the BATFET Q2 is turn on fully to supply the system, and the charger enters into Battery Discharge Mode(DISCHG), when the host set SWITCH_MD=1, the device enter low power consumption mode. Further, the device can turn off BATFET so that the system voltage is zero to minimize the battery leakage current. When the host set FET_DIS=1, the charger can turn off BATFET Q2 and entries Shipping Mode(SHIP). When the host set SWITCH_MD=1, the charger can turn on BATFET Q2 and turn off all protection function (SWITCH).

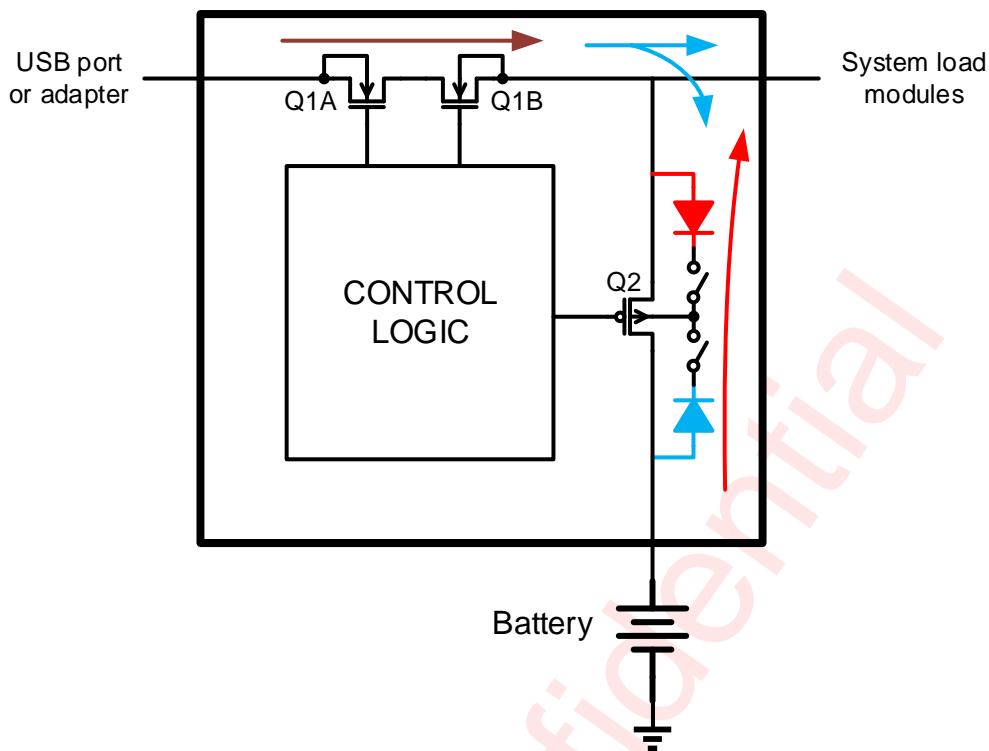

Figure 12 Power Path management Structure

In Battery Charge Mode, the Q2 works as a fully featured linear charger with pre-charge, fast charge, constant voltage charge, charge termination, auto-recharge, thermal protection, built-in timer control and NTC monitoring. The charge current can be programmed via the I²C interface. When the chip's temperature exceeds the thermal regulation threshold (120°C default), the IC controls the charge current to reduce its temperature.

Power Supply

The AW32012A chooses the higher voltage of either BAT or IN to power VDD and the internal bias circuit, showed as Figure 13. When BAT or IN voltage rises above its respective power on reset (POR) threshold, the internal control circuit will wake up and the I²C interface will be ready for communication with all of registers reset to default value. These registers can be controlled by the host.

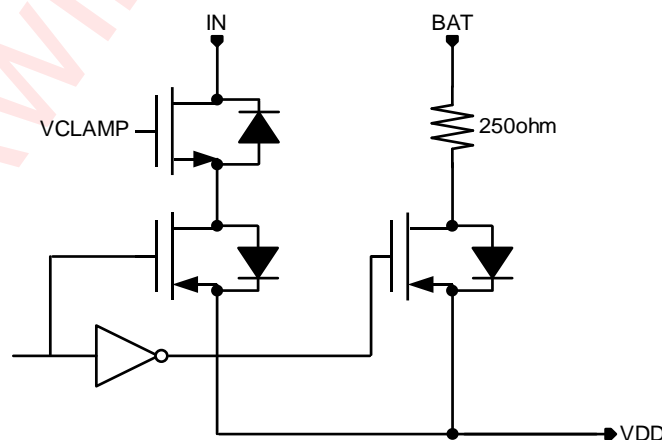

Figure 13 The inner power supply sources selection circuit for VDD

VIN OVP, VIN UVLO and VIN GOOD

The AW32012A has an input UVLO and over-voltage protection (OVP) threshold. The Q1 is turned off immediately when the input voltage is out of its operating range.

The input over-voltage protection is integrated to prevent the device and other components from damage of the high input voltage (Voltage from V_{IN} to GND). If the voltage at V_{IN} pin exceeds V_{IN_OVP} threshold(6V typical), the chip will turn off Q1. When V_{IN} drops lower than the input overvoltage exit threshold (5.65V typical) and continues to exceed T_{DGL_OVP} (30ms typical), Q1 will be turned on again.

When V_{IN} falls below V_{UVLO} , the Q1 is also turned off and the input to system loop controller is shut down. Once V_{IN} rises above $V_{UVLO}+300mV$ and continues to exceed T_{DGL_UVLO} (30ms typical), the Q1 is turned on and relative circuits start working.

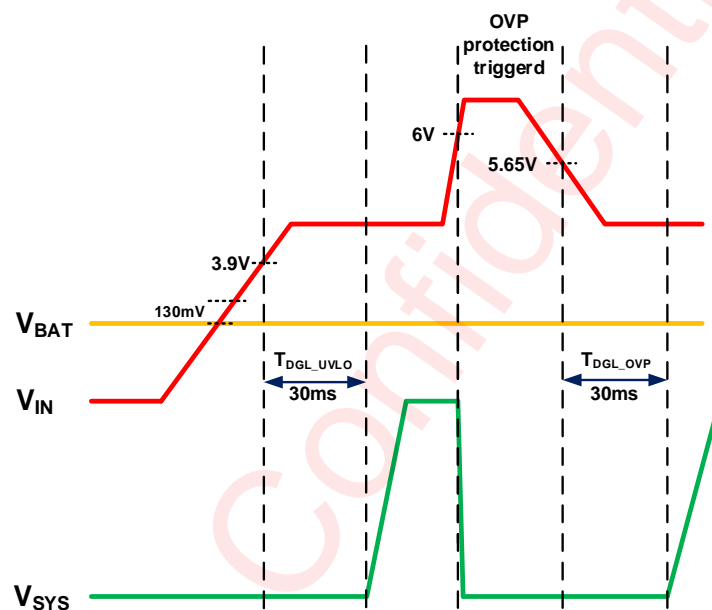

Figure 14 Input Power Detection Operation

Either V_{IN} OVP or V_{IN} UVLO had happened, the device send out a $256\mu s$ low-state interrupt pulse from INT port, indicated a power fail status as $REG08H[1]=0$ and a fault status as $REG09H[5]=1$, which are read clear.

The VIN GOOD status not only means that V_{IN} is between V_{IN_UVLO} and V_{IN_OVP} , but also includes that the V_{IN} voltage increase is higher than $V_{BAT}+170mV$ (130mV typical), and higher than $V_{SYS}+75mV$ (50mV typical). The all conditions have satisfied, and enter VIN GOOD. VIN voltage reduction meets $V_{IN}<V_{BAT}+60mV$ or $V_{IN}<V_{SYS}$, exiting VIN GOOD.

Only Power System Mode

The device meets VIN GOOD, $EN_HIZ=0$ ($REG01H[4]=0$) and $CEB=1$ ($REG01H[3]=1$), and firstly enter Only Power System Mode(OPSM) which just turns on Q1A and Q1B, and supplies power the down-stream system by VBUS. If the device is configured $CEB=0$ ($REG01H[3]=0$), the main state machine switches to Charge Mode from the Only Power System Mode.

Charge Mode

When AW32012A operation in Charge Mode, the DPM, PPMF, Battery Supplement and other functions are available. These functions are useful in some application.

Battery Regulation Voltage

The battery voltage of constant voltage regulation state is V_{BAT_REG} . When $V_{BAT_REG} = 4.2V$, the accuracy is $\pm 0.5\%$ in the range of $0^{\circ}C$ to $+50^{\circ}C$ ambient temperature.

Input Current and Input Voltage-Based Power Regulation

The AW32012A has an input current limit regulation to meet the input source's (typically USB) maximum current limit specification. The function is realized by monitoring the input current continuously. If the rating of input source is lower than the preset input current limit, the input current limitation works to protect the input source from being overloaded. The total input current limit value can be set by the register IIN_LIM (REG00H[3:0]), and the function can prevent the input source from being over-loaded.

Otherwise, when the load is over the input power capacity, the input voltage also can be regulated to V_{IN_DPM} for the input voltage-based DPM regulation. V_{IN_DPM} can be set via the register VIN_DPM (REG00H[7:4]), and the V_{IN_DPM} should be at least 250mV higher than V_{BAT_REG} to ensure the stable operation of the regulator. The register DIS_VINLOOP=1 (REG07H[6]=1) can be set to disable the input voltage limit function.

Either the input voltage or input current limit is reached, the total input power is limited by regulating the Q1B FET between IN and SYS. As a result, the system voltage drops. When the system voltage decrease to a **minimum value** of $V_{SYS_REG} - 135mV$ and $V_{IN} - 345mV$, the charge current is reduced to prevent the system voltage from dropping further.

Power Path Management Function (PPMF)

The AW32012A can decouple the system from the battery by employs a PPMF with the Q2, which allows the device to control Q2 between the system and the battery separately. The system has high priority to start up by regulating the integrated Q1B even the battery is in a deeply discharged or missing state. The function of Q1A, Q1B and Q2 can be controlled by the I²C as shown in table 1.

Table 1: FET Control via I²C

FET On/Off Changed by Control	HI-Z Mode and Charge Control	
	Set EN_HIZ = 1	Set CEB = 1
Q1A and Q1B	OFF	x
Q2(Charge Mode)	x	OFF
Q2(Battery Discharge Mode)	x	x

NOTE: x=Don't care.

For the system voltage control, when the input voltage is lower than V_{SYS_REG} , the Q1A and Q1B are fully on with the input current limit. When the input voltage is higher than V_{SYS_REG} , the system voltage is regulated to V_{SYS_REG} . The V_{SYS_REG} can be programmed through REG07H[3:0].

Battery Supplement Mode

When DPM occurs, the charge current is reduced to keep the input current or input voltage in regulation. If the charge current has already reduced to zero and the input source is still overloaded, the system voltage begins decreasing. If the system voltage drops to 30mV below the battery voltage, the AW32012A will enters battery supplement mode, and the ideal diode is enabled. If I_{DSCHG} (supplement current) * R_{ON_BATT} is lower than 30mV, the Q2 is regulated to keep $V_{BAT} - V_{SYS}$ at 30mV. If this regulation cannot maintain 30mV voltage drop due to heavy load from SYS, the Q2 will fully turn on to maintain the ideal forward voltage. When the system load decreases, the system voltage starts to increase. The ideal diode mode is disabled, when V_{SYS} is higher than $V_{BAT} + 20mV$. Figure 15 shows the DPM and battery supplement mode operation profile.

When V_{IN} is not available, the AW32012A operates in discharge mode. During in discharge mode, the Q2 is fully on to reduce power loss.

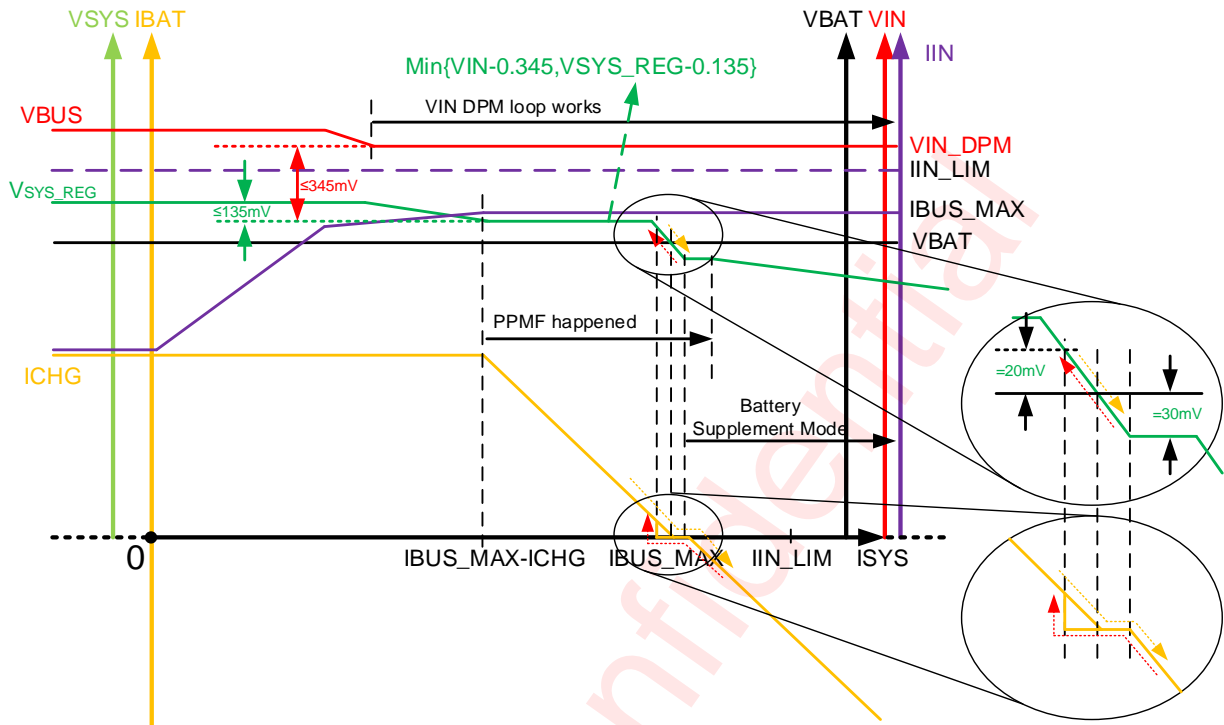

Figure 15 DPM and Battery Supplement Operation Profile (Bad adaptor inserted)

NOTE: $IBUS_MAX$ is the maximum output current of the input source.

Battery Charge Profile

The AW32012A has three main charging processes: pre-charge, fast constant current charge(CC), and fast constant voltage charge(CV):

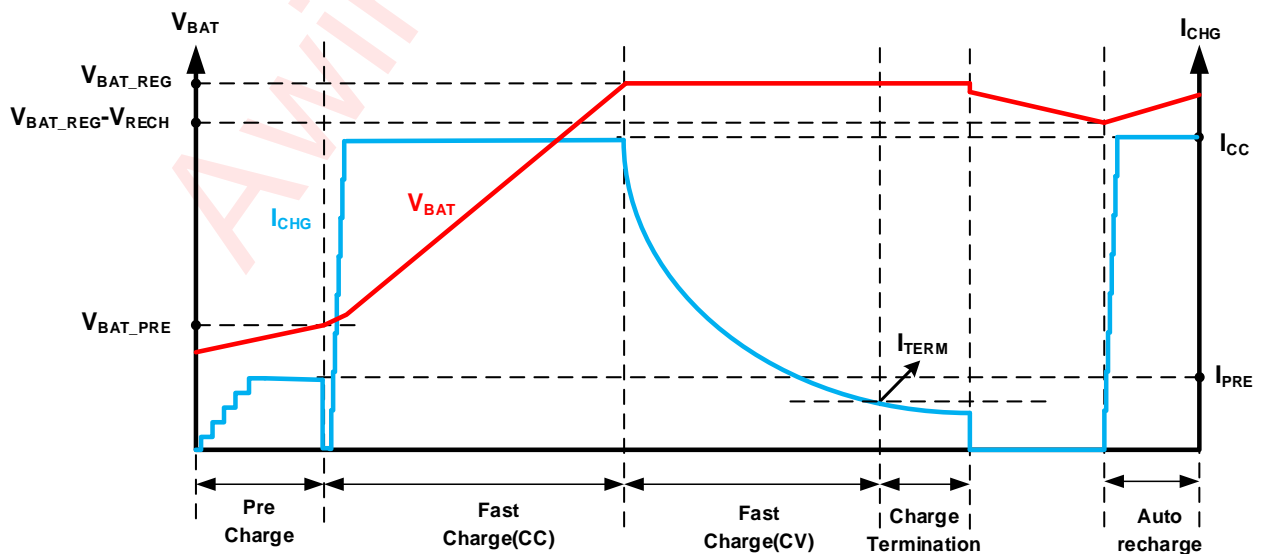

Figure 16 Battery Charge Profile

- Pre-charge: In the pre-charge process, the IC charges the deeply depleted battery safely with small current until the battery voltage rise to the pre-charge threshold (V_{BAT_PRE}), and then the chip enters the fast-charge process. If the V_{BAT} is not increasing to exceed than V_{BAT_PRE} before the pre-charge timer expires (1 hour), the charge cycle stops, and a corresponding timeout fault signal is asserted. The register REG03H[3:0] can be set the current of pre-charge.
- Fast constant current charge: When V_{BAT} exceeds V_{BAT_PRE} , the AW32012A enters the fast constant charge process. The REG02H[5:0] can be set to change the fast-charge current .
- Constant voltage charge: The charge mode changes from CC mode to CV mode when the V_{BAT} rises to the battery-full voltage (V_{BAT_REG}) set via REG04H[7:2]. At the same time, the charge current starts decreasing in CV charge process.

Due to multiple loop regulations, such as dynamic power management (DPM) regulation (input voltage, input current) or thermal regulation, the actual charge current may be less than the setting value.

When the charge current is smaller than termination current threshold I_{TERM} for 3.2s in CV process, the charge cycle will be completed, and the charge status is updated to charge done. The register REG03[3:0] can set the termination charge current threshold I_{TERM} . The termination function can be disabled via EN_TERM=0 (REG05H[4]=0). Meanwhile, the register bit TERM_TMR (REG05H[0]) is able to control whether the charge process continue or not when the termination conditions are met. The termination function is shown as table 2.

Table 2: Termination Function Selection Table

EN_TERM	TERM_TMR	After Termination Condition is Met	
		Operation	Charge Status
0	x	Keep CV Charge	Charge
1	0	Charge done	Charge done
1	1	Keep CV Charge	Charge

Note: x=Don't care.

A new charge cycle starts when any of the following conditions are valid:

- Auto-recharge kicks in.
- Battery charging is enabled via the I²C.
- The input power is recycled .

Under the following conditions:

- No safety timer fault.
- No thermistor fault at NTC.
- BFET is not forced off.
- No battery over-voltage event.

Automatic and manual Recharge

After the charge process is completed and charge cycle is terminated, the system's consumption or battery self-discharge may cause the battery voltage to decrease.

When the battery voltage falls below the recharge threshold and V_{IN} is still in the operating range, another new charging cycle will start automatically.

When the battery voltage falls above the recharge threshold and V_{IN} is still in the operating range, another new charging cycle can be made by setting $EN_TERM=1 \rightarrow 0 \rightarrow 1$ sequence, and the low voltage duration should be greater than 1s.

The recharge threshold (below V_{BAT_REG}) V_{RECH} can be configured to 50mV, 100mV or 200mV (default) via $REG0DH[3]$, $REG04H[0]$.

Battery Discharge Mode

In Battery discharge mode, The device has low quiescent current and low on-resistance of Q2 to help the battery working for a longer time. Once the discharge current exceeds the over discharge current threshold, the over discharge current protection works and ensures the IC work safely in different applications.

In discharge mode, the device can work in switch mode (which can be programmed by $REG0DH[0]$) to save quiescent current.

Battery Discharge Function

When the input source is absent and battery is connected to chip with the V_{BAT} above V_{BAT_UVLO} threshold, the Q2 is fully on. During discharge mode, the $100m\Omega$ Q2 can minimize conduction loss.

Battery Disconnection Function

In some applications where the battery is not removable, it is essential to allow the system power to be reset in some applications or disconnect the battery from the system for shipping mode. The AW32012A provides both system reset function and shipping mode for different applications.

The INT pin can be used to cut off the path from the battery to the system under certain condition to reset the system manually. The battery is disconnected from the system, when the logic of INT is set low for longer than t_{RST_DGL} (which can be programmed by $REG01H[7:6]$). After a delay time of t_{RST_DUR} ($REG01H[5]$), the Q2 is turned on automatically, and the system is powered by the battery again. The t_{RST_DUR} can be programmed by $REG01H[5]$. During the off period, the INT pin is not limited to be high or low. Please notes that the t_{RST_DGL} counter is triggered by the falling edge of INT.

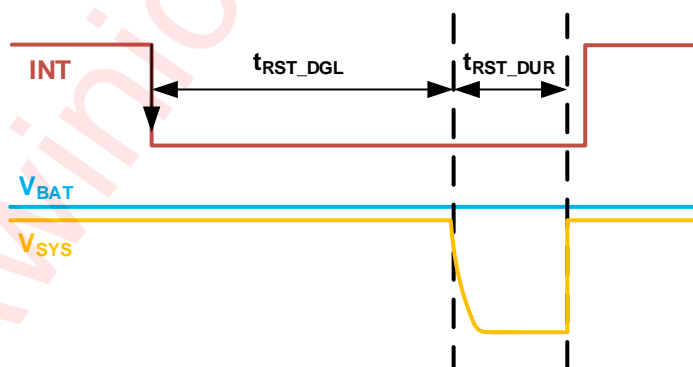

Figure 17 A System Reset Function Operation Timing Diagram

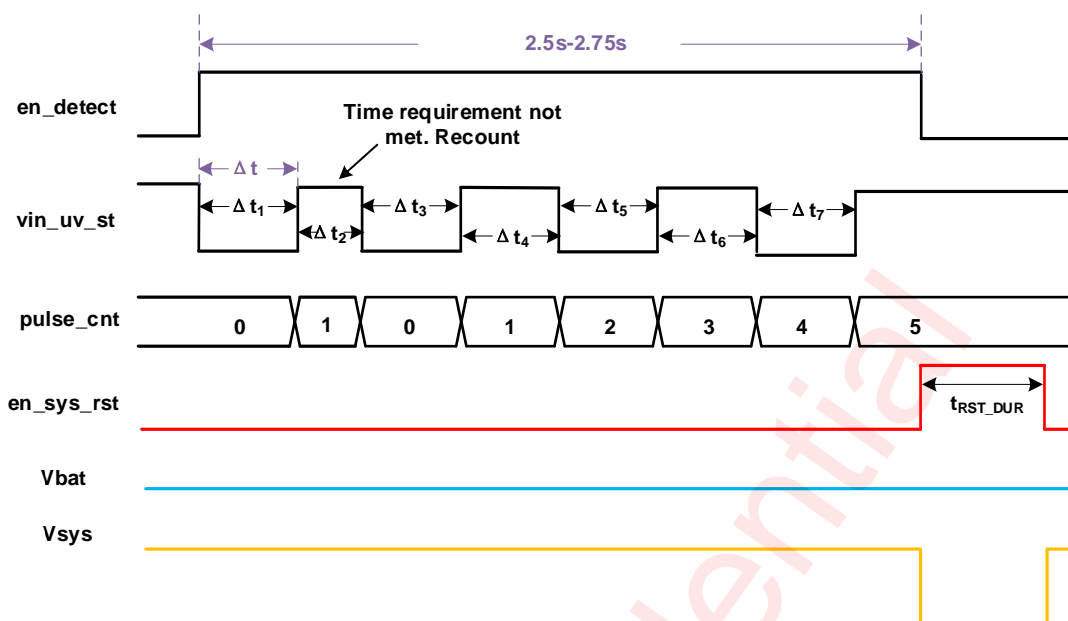

Figure 17 B System Reset Function Operation Timing Diagram

The VIN pin can also be used to cut off the path from the battery to the system under certain conditions to reset the system manually. The battery is disconnected from the system when the VIN pin is pulled high and low actions are satisfied. Within a detection cycle, if the charger detects five consecutive active high and low levels, the charger will send a signal `en_sys_rst` to reset the system. The time of active high and low pulses Δt should be greater than 200ms and less than 400ms, and the detection cycle time is between 2.5s and 2.75s.

Shipping Mode

The register bit `FET_DIS` (REG06H[5]) can be used to control the battery disconnection too. If the input source is absent, once setting `FET_DIS=1`, the AW32012A enters shipping mode after a delay time (default 1s). The delay time can be programmed by `EN_SHIPPING_DGL` (REG09H[7:6]). If the input source is present when `FET_DIS` is written to 1, the chip will turn to shipping mode after 1s deglitch time with input voltage smaller than `VIN_UVLO` threshold. Plug in the input adapter or pull the INT pin down for 2s or 100ms to wake the AW32012A up from shipping mode and clear `FET_DIS` to 0. The waking time can be configured in `EN_SHIPMD_0P1S` (REG0BH[0]) and `INT100mS` (REG0DH[2]).

If INT PIN is shorted to ground or left floating before entering Shipping Mode, `DIS_SHIPINT` (REG0CH[2]) must be written to 1 to avoid bad Shipping Mode operation. In this case, the only method of exiting shipping mode is plugging in the input adapter.

Table 3: Shipping Mode Control

FET On/Off Changed by Control	Enter Shipping Mode	Exit Shipping Mode	
	Set <code>FET_DIS</code> to 1	INT H to L for 2s	Vin Plug-In
Q1	x	x	On
Q2	Off(1s later)	On	On(2s later)

Note: x=Don't care.

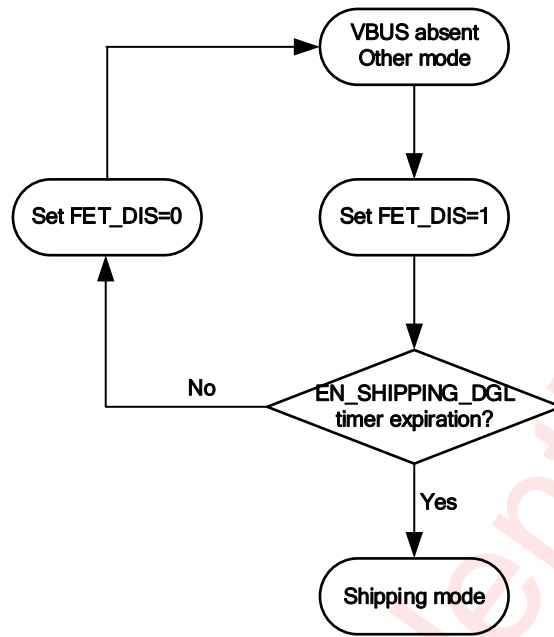

Figure 18 Enter Shipping Mode Timing Diagram(VBUS absent)

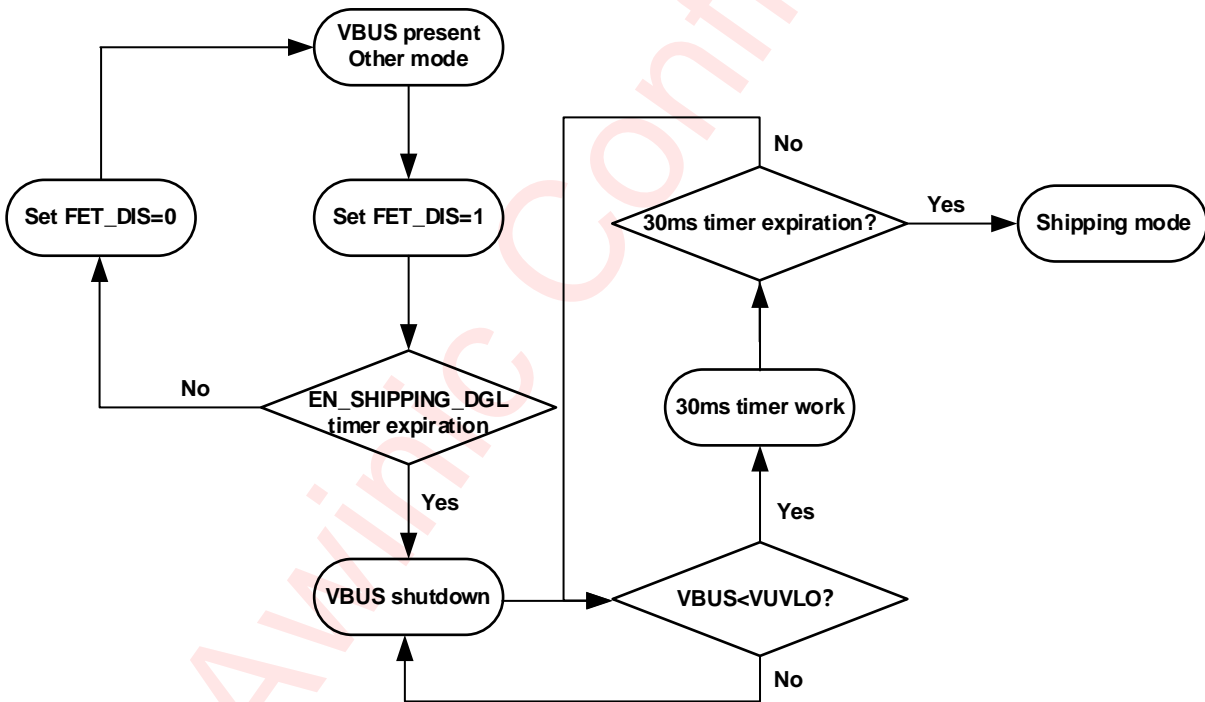

Figure 19 Enter Shipping Mode Timing Diagram(VBUS present)

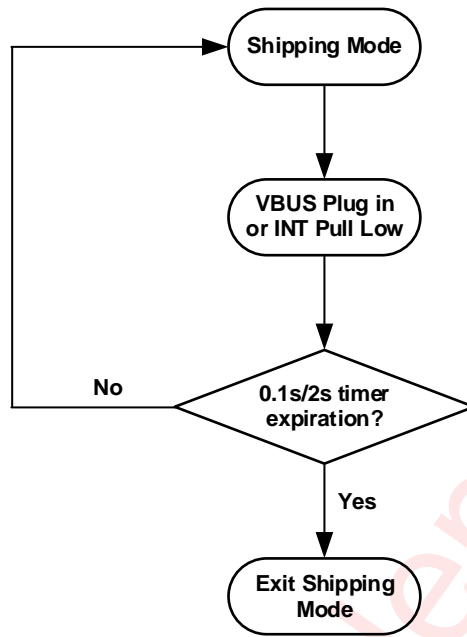

Figure 20 Exit Shipping Mode Timing Diagram

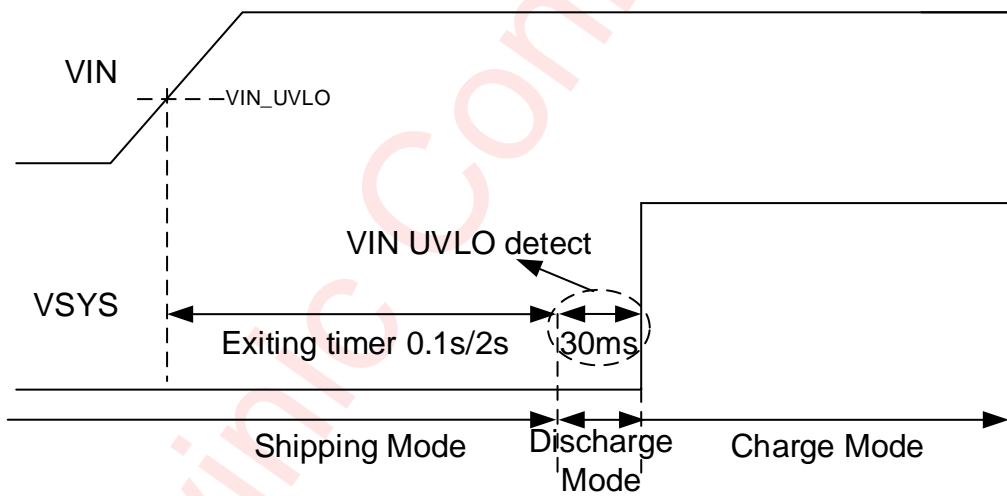

Figure 21 Recovery charging From Shipping Mode Operation Timing Diagram(VBUS Plug-In)

Protection Operation

The AW32012A has input OVP, UVLO, battery OVP and other functions to protect its normal operation. Additionally, NTC function is integrated to prevent battery from high temperature danger. The following table 4 is summary all fault functions.

Table 4: All fault functions summary table

Status	Operation Mode	Brief Function Description	Interrupt	Action
VIN GOOD	Charge, OPSPM	V_{IN} rises above $V_{BAT}+170mV$ and $V_{SYS}+75mV$, the device enters into VIN Good, V_{IN} falls down $V_{BAT}+60mV$ or $V_{SYS}-50mV$, exits VIN GOOD. Entry and exit require 2ms to confirm.	Yes	Turn on Q1A and Q1B.
VIN UVLO	Charge, OPSPM	V_{IN} falls down 3.6V, the device enters VIN UVLO immediately. V_{IN} rises above 3.9V and keeps 30ms, the device exits.	Yes	Turn off Q1A and Q1B.
VIN OVP	Charge, OPSPM	V_{IN} rises above 6V/7.5V, the device enters into VIN OVP immediately, V_{IN} falls down about 5.65V/7.15V, exits VIN OVP. Exit requires 2ms to confirm.	Yes	Quickly turn off Q1B in 100ns.
VBAT OVP	Charge	After V_{BAT} rises above $V_{BAT_REG}+130mV$ about 128 μs , the device enters into VBAT OVP. Once V_{BAT} falls down $V_{BAT_REG}+50mV$ about 2ms, exits VBAT OVP.	Yes	Turn off Q2.
VBAT UVLO	Discharge, OPSPM	When V_{BAT} rises above $V_{BAT_UVLO}+190mV$ about 31ms (programmable 128 μs), the device exits into V_{BAT} UVLO. Once V_{BAT} falls down V_{BAT_UVLO} (programmable), enters V_{BAT} UVLO immediately.	No	Turn off Q2.
OTP	Charge, OPSPM, Discharge	When the junction temperature exceeds 150°C, IC shuts down. When the junction temperature falls below the thermal recovery temperature, approximately 120°C, the device restarts by using the soft-start sequence.	Yes	Turn off Q1B and Q2.
PCB OTP	Charge, OPSPM, Discharge	If PCB_OTP function is setting enable. V_{NTC} falls down $V_{DD}\times 33\%$, PCB OTP is valid; Once V_{NTC} rises up $V_{DD}\times 33\%+70mV$ for 31ms, the device exits PCB OTP.	Yes	Turn off Q1B and Q2.
NTC HOT	Charge	NTC HOT function is configured. V_{NTC} falls down $V_{DD}\times 33\%$, the device judges battery hot, and reports NTC HOT; Once V_{NTC} rises up $V_{DD}\times 33\%+70mV$ for 31ms, the device exits NTC HOT.	Yes	Turn off Q2.
NTC COOL	Charge	NTC COOL function is configured. V_{NTC} rises up $V_{DD}\times 64\%$, the device judges battery cold, and reports NTC COOL; Once V_{NTC} falls down $V_{DD}\times 64\%-60mV$ for 31ms, the device exits NTC COOL.	Yes	Turn off Q2.

VSYS SCP	Charge, OPSP, Discharge	When the events including $I_{SYS} > I_{OCP_INSYS}(2A)$, $I_{SYS} > I_{OCP_BATSYS}(3.7A)$, $I_{IN_LIM} < I_{SYS} < I_{OCP_INSYS}$ for 60 μ s, and $I_{DSCHG} < I_{SYS} < I_{OCP_BATSYS}$ for 60 μ s happen during V_{SYS} launch and $V_{SYS} < 0.7V$, or during working normally and $V_{SYS} < 1.5V$, the device triggers V_{SYS} short protection immediately and work in Hiccup Mode. Turn off Q1 and Q2, and start up again after 1ms later.	No	Hiccup Mode. Turn off Q1 and Q2, and start up again after 1ms later
VBAT OCP	Discharge, Supplement Mode	Over-discharge current protection. Once the I_{BAT} exceeds the programmable discharge current limit I_{DSCHG} (2A default) for 60 μ s. The AW32012A enters hiccup mode. In addition, if the discharge current goes high and reaches the internal fixed peak current limit (about 3.7A), the Q2 turns off and begins hiccup mode immediately.	No	Q2 turns off
Watch Dog fault	Charge, OPSP, Discharge	When the watchdog timer expires,, both the Q1 and Q2 are turned off, and most registers return to the default value, sent a watch dog fault interrupt to system.	Yes	Turn off Q1B and Q2. Reset CEB to 1.
Safety time fault	Pre Charge, Fast Charge	Pre-charge for more than 1 hour (Configurable), or faster charge for more than 5 hours (Configurable), entry to safety time fault.	Yes	Turn off Q1B and Q2. Reset CEB to 1.

Battery OVP(VBAT OVP)

The AW32012A has battery over-voltage protection (VBAT OVP) function (about 130mV higher than V_{BAT_REG}). When the battery OVP event occurs, AW32012A will stop the current charging cycle immediately and assert a fault.

Negative Temperature Coefficient (NTC) Temperature Sensor

The AW32012A is able to use NTC to sense the battery temperature, By monitoring the thermistor (usually available in the battery pack), the battery is guaranteed to operate in safe environment.

The NTC function demands appropriately valued resistors connecting from VDD to NTC to ground. At the same time, connect a thermistor from the NTC pin to ground. The NTC voltage is determined by the resistor divider and thermistor, and the divide ratio depends on the temperature of thermistor. The upper and lower bound of NTC voltage is pre-determined in AW32012A.

In the AW32012A, PCB_OTP function is default settings disable. The I²C can change the NTC and PCB_OTP functions (see Table 5).

Table 5: NTC Function Selection Table

I ² C Control		Function
EN_NTC	DIS_PCB_OTP	
0	x	Disable (Default)
1	1	NTC(resistor-divided)
1	0	PCB_OTP

NOTE: x=Don't care

When PCB_OTP is selected and the NTC voltage is lower than the NTC hot threshold, both the Q2 and Q1 are turned off. The NTC_FAULT status is set (REG09H[1]) to 1 to show the PCB_OTP fault. The IC Operation resumes, when the NTC voltage returns to safe range.

The NTC function works only in charge mode. Once the temperature is outside of the safe operating range, the IC stops charging state and report it on the status bits. When the temperature comes back to the safe range, the charge process resumes automatically.

Thermal Regulation and Thermal Shutdown

The internal junction temperature is monitored continuously to avoid overheating the chip and maximize power delivery. When the internal junction temperature reaches the preset limit T_{J_REG} (120°C default), the charge current starts reducing to prevent dangerous high power dissipation. The IC can work in different thermal requirements applications, because it has multiple thermal regulation thresholds from 60°C to 120°C. register REG07H bit [5:4] can set The junction temperature regulation threshold.

The device has a built-in temperature sensor which monitors the internal junction temperature. When the junction temperature exceeds 150°C, the Q1 and Q2 will turn off. When the junction temperature falls below the thermal recovery temperature, approximately 120°C, the device reworks.

System Short-Circuit Protection(VSYS SCP)

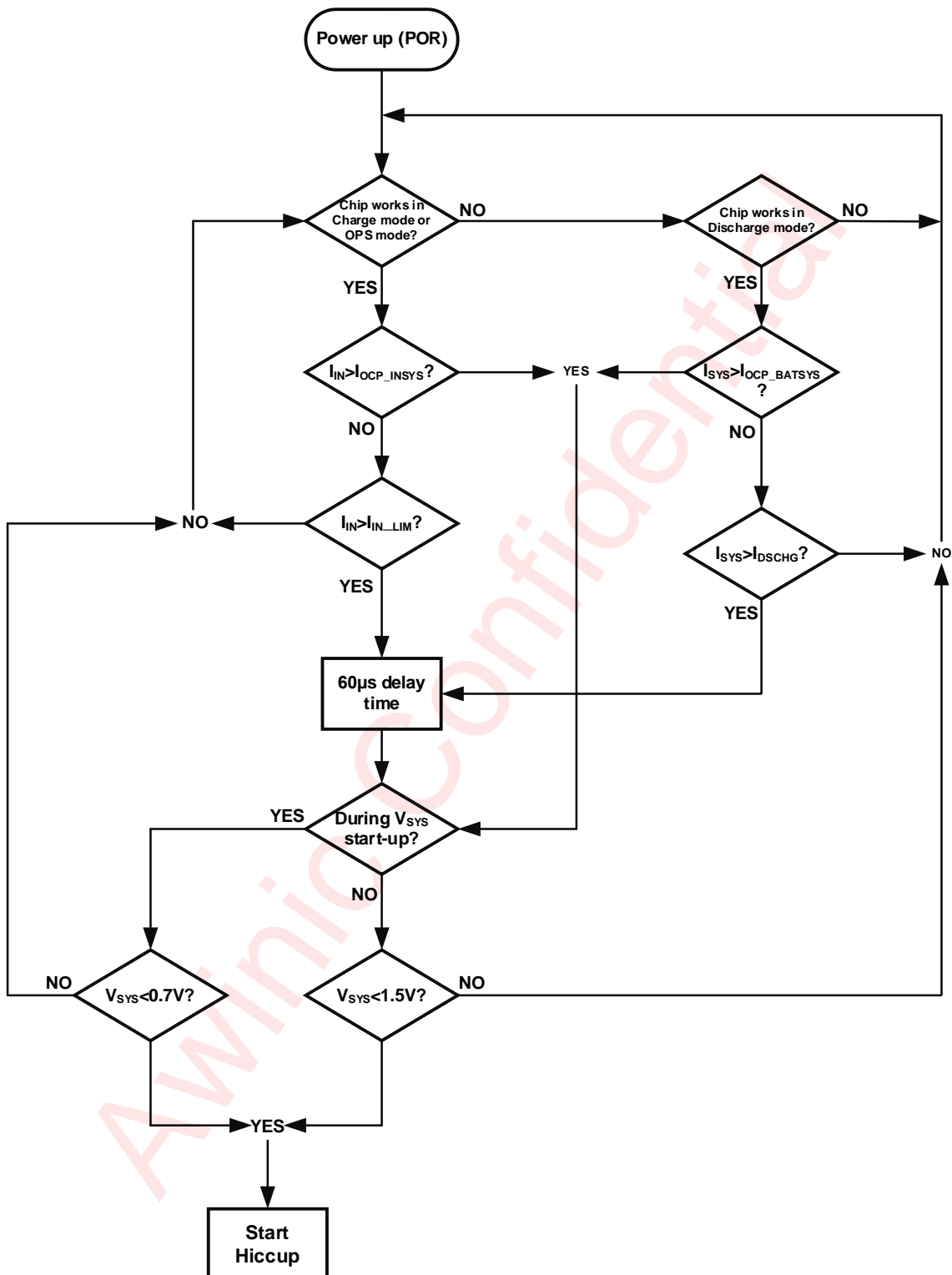

Figure 22 Short Circuit Hiccup Protection Flow Chart

The AW32012A has short-circuit protection (SCP) function in both the IN to SYS path and the BAT to SYS path. The IC monitor the system voltage continuously. If V_{SYS} is lower than 1.5V, The SCP is active, and I_{DSCHG} decreases to half of the original value. For the IN to SYS path, once I_{IN} is over the 2A protection threshold I_{OCP_INSYS} , both the Q1 and Q2 are turned off immediately, and the AW32012A enters hiccup mode. When the

setting input current limit I_{IN_LIM} is reached, I_{IN} is regulated at I_{IN_LIM} . After a $60\mu s$ delay, the hiccup mode starts, and the hiccup mode interval is 1ms. For the BAT to SYS path, once I_{BAT} is over the 3.7A protection threshold I_{OCP_BATSYS} , both the Q1 and Q2 are turned off immediately, and the AW32012A enters hiccup mode. When the battery discharge current limit threshold I_{DSCHG} is reached, hiccup mode starts after a $60\mu s$ delay, and the hiccup mode interval is 1ms.

Particularly, when system short-circuit occurs in both the input and battery, the both paths protection mechanism works together. The faster path dominates the hiccup operation.

Over-Discharge Current Protection

In discharge mode and supplement mode, the AW32012A is designed to have an over-discharge current protection. Once the I_{BAT} exceeds the programmable discharge current limit (2A default), the Q2 turns off after a $60\mu s$ delay. At the same time, the AW32012A enters hiccup mode as part of the over-current protection (OCP). The discharge current can be programmed to maximal 3.2A through the I²C. In addition, if the discharge current goes high and reaches the internal fixed peak current limit (about 3.7A), the Q2 turns off and begins hiccup mode immediately.

Safety timer

Because the abnormal battery conditions, the AW32012A designed a pre-charge and fast-charge safety timer to prevent an extra-long time charging cycle. The pre-charge safety timer is 1hour, and the fast-charge safety timer can be programmed through the I²C. Once the battery enters fast-charge mode, The fast charge safety timer starts. The safety timer can be disabled via the I²C. When charger works in VIN DPM or Temp regulation state, the charge current will decrease. In order to charge as full as possible, the register bit TMR2X_EN(REG06H[6]) could be set 1, which enable the timer slows down, the left safety time is double. If VIN DPM or Temp regulation state exit, or TMR2X_EN=0, the timer recovery normal.

The following actions can restart the safety timer:

- Write REG05H[3] from 0 to 1 (safety timer enable).
- Write REG01H[3] from 1 to 0 (charge enable).
- Write REG02H[7] from 0 to 1 (reg reset).
- A new charge cycle is kicked in.

Interrupt to host (INT)

The AW32012A can output a $256\mu s$ low-state INT pulse via INT to notify the system of the operation. All of the below events can trigger an INT output:

- Charge completed
- Good input source detected
- Charging status change
- UVLO or input over-voltage protection
- Any fault in REG09H and REG08H (watchdog timer fault, safety timer fault, thermal fault, battery OVP fault, NTC fault)

When a fault occurs, an INT pulse is send out and latches the fault state in REG09H. After the AW32012A exits the fault state, the fault bit is reset to 0 after the host reads faults registers. The NTC fault bit constantly reports the current thermistor conditions without latches. The INT signal can be masked when the corresponding control bit is set in REG06H[4:0]. When an INT condition is masked, this means that the INT pin signal (and register bit) will not trigger when the corresponding condition occurs. Masking INT pulses is useful when writing software code to avoid unnecessary interruptions due to these events.

Watchdog Timer

In charge mode and OPS mode, the watchdog timer is valid by default. In discharge mode, the watchdog timer is disabled by default, and can be turned on by setting REG05H[7]=1. When the REG05H[6:5] is set to 00, the watchdog timer is disabled under both charge mode and discharge mode regardless of the status of REG05H[7]. If the watchdog timer (REG05H[6:5]) is not disabled, the host must reset the watchdog timer regularly by writing 1 to REG02H[6] before the watchdog timer expires to keep the device work properly.

In both charge and discharge mode, once the watchdog timer run out, both the Q1 and Q2 are turned off, and most registers return to the default value (refer to the I²C Register Map section). The Q1 and Q2 are turn on again automatically after t_{RST_DUR} , which can be programmed by REG01H[5].

General I²C Operation

The device supports the I²C serial bus and data transmission protocol. It operates as a slave on the I²C bus. The maximum clock frequency specified by the I²C standard is 400kHz. Connect to the bus are made via the open-drain I/O pins SCL and SDA. The pull-up resistor can be selected in the range of 1k~10kΩ and the typical value is 4.7kΩ when I²C frequency is 400kHz. Different high level from 1.2V to 5V of this I²C interface is supported.

Device Address

AW32012A 7-bit slave address (A7~A1) is 1001001 binary(0x49H). After the START condition, the I²C master sends the 7-bit chip address followed by an eighth (A0) read or write bit (R/W). R/W= 0 indicates a WRITE function and R/W = 1 indicates a READ function.

Table 6: Device Address

A7	A6	A5	A4	A3	A2	A1	A0
1	0	0	1	0	0	1	R/W

Data Validation

When SCL is high level, SDA level must be constant. SDA can be changed only when SCL is low level.

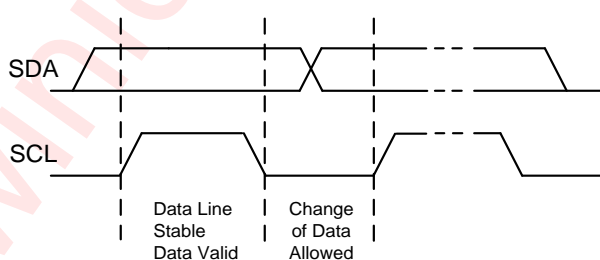

Figure 23 Data Validation Diagram

I²C Start/Stop

I²C start: SDA changes from high level to low level when SCL is high level.

I²C stop: SDA changes from low level to high level when SCL is high level.

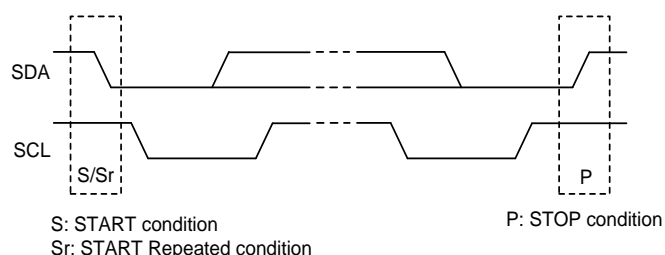

Figure 24 Start and Stop Conditions

ACK (Acknowledgement)

ACK means the successful transfer of I²C bus data. After master sends 8bits data, SDA must be released; SDA is pulled to GND by slave device when slave acknowledges.

When master reads, slave device sends 8bit data, releases the SDA and waits for ACK from master. If ACK is send and I²C stop is not send by master, slave device sends the next data. If ACK is not send by master, slave device stops to send data and waits for I²C stop.

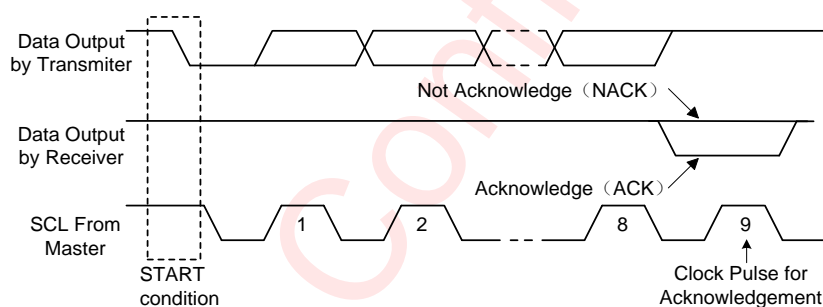

Figure 25 Acknowledgement Diagram

Write Process

One data bit is transferred during each clock pulse. Data is sampled during the high state of the serial clock (SCL). Consequently, throughout the clock's high period, the data should remain stable. Any changes on the SDA line during the high state of the SCL and in the middle of a transaction, aborts the current transaction. New data should be sent during the low SCL state. This protocol allows a single data line to transfer both command/control information and data using the synchronous serial clock.

Each data transaction is composed of a Start Condition, a number of byte transfers (set by the software) and a Stop Condition to terminate the transaction. Every byte written to the SDA bus must be 8 bits long and is transferred with the most significant bit first. After each byte, an Acknowledge signal must follow.

In a write process, the following steps should be followed:

- Master device generates START condition. The "START" signal is generated by lowering the SDA signal while the SCL signal is high.
- Master device sends slave address (7-bit) and the data direction bit ($r/w = 0$).
- Slave device sends acknowledge signal if the slave address is correct.
- Master sends control register address (8-bit)
- Slave sends acknowledge signal

- f) Master sends data byte to be written to the addressed register
- g) Slave sends acknowledge signal
- h) If master will send further data bytes the control register address will be incremented by one after acknowledge signal (repeat steps f and g)
- i) Master generates STOP condition to indicate write cycle end

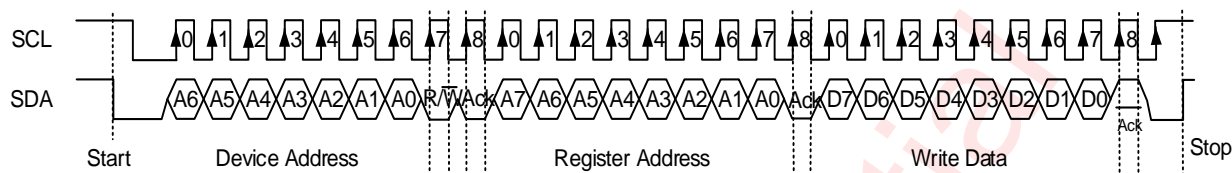

Figure 26 I²C Write Timing

Read Process

In a read cycle, the following steps should be followed:

- a) Master device generates START condition
- b) Master device sends slave address (7-bit) and the data direction bit ($r/w = 0$).
- c) Slave device sends acknowledge signal if the slave address is correct.
- d) Master sends control register address (8-bit)
- e) Slave sends acknowledge signal
- f) Master generates STOP condition followed with START condition or REPEAT START condition
- g) Master device sends slave address (7-bit) and the data direction bit ($r/w = 1$).
- h) Slave device sends acknowledge signal if the slave address is correct.
- i) Slave sends data byte from addressed register.
- j) If the master device sends acknowledge signal, the slave device will increase the control register address by one, then send the next data from the new addressed register.
- k) If the master device generates STOP condition, the read cycle is ended.

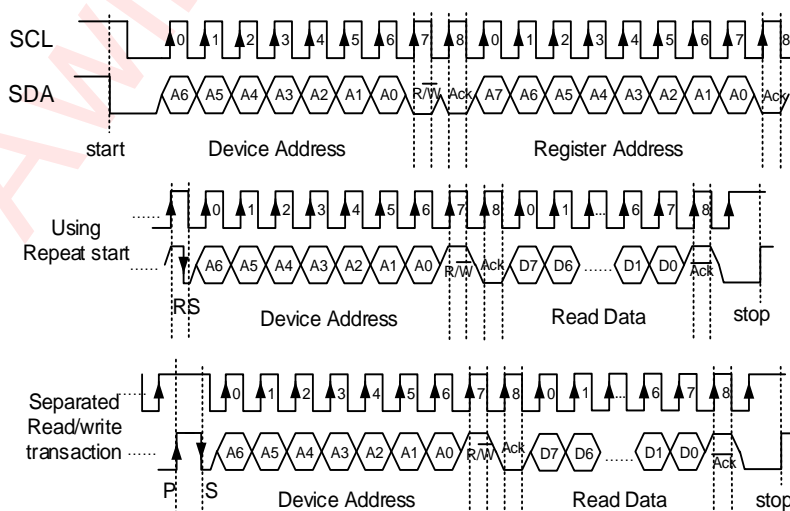

Figure 27 I²C Read Timing

Register List

Register Map

R/W = Read/Write, RC = Read Clear.

ADDR	0x00	0x01	0x02	0x03	0x04
NAME	Input Source Control	Power On Configuration	Charge Current Control	Discharge Current Control	Charge Voltage
Default	0x8F	0xAC	0x0F	0x91	0XA3
Bit7	VIN_DPM[3:0]	$t_{RST_DGL}[1:0]$	REG_RST	IDSCHG[3:0]	VBAT_REG[5:0]
Bit6			WD_TMR_RST		
Bit5		t_{RST_DUR}	ICHG[5:0]		
Bit4		EN_HIZ			
Bit3	CEB	ITERM[3:0]			
Bit2	VBAT_UVLO[2:0]				
Bit1			IIN_LIM[3:0]		
Bit0			VRECH		

ADDR	0x05	0x06	0x07	0x08
NAME	Charger Termination/Timer Control	Main Control	System Voltage Control	System Status
Default	0x7A	0xC0	0x38	0x60
Bit7	EN_WD_DISCHG	EN_NTC	DIS_PCB_OTP	Watchdog_Fault
Bit6	WATCHDOG[1:0]	TMR2X_EN	DIS_VINLOOP	DEV_ID[1:0]
Bit5		FET_DIS	TJ_REG[1:0]	
Bit4	EN_TERM	PG_INT_CONTROL		VSYS_REG[3:0]
Bit3	EN_STMR	EOC_INT_CONTROL	VINDPM_ST	
Bit2	CHG_TMR[1:0]	CHG STATUS_INT_CONTROL	PG_STAT	
Bit1		NTC_INT_CONTROL	THERM_STAT	
Bit0	TERM_TMR	BATOV_P_INT_CONTROL		

ADDR	0x09	0x0A	0x0B	0x0C	0x0D
NAME	Fault	Address	Individual Charge	Additional Function Control	Additional Function Control
Default	0x40	0x49	0x43	0x00	0x00
Bit7	EN_SHIPPING_DGL[1:0]	CHIPID[7:0]	EN_ICHG_DIVD	EN0P55	Reserve[3:0]
Bit6			EN_TREG	ITERMDEG	
Bit5	VIN_FAULT		EN_IPRE_SET	Reserve[1:0]	
Bit4	THEM_SD		IPRE[3:0]	PRE_SFTO	
Bit3	BAT_FAULT			DIS_SHIP_INT	INT100ms
Bit2	STMR_FAULT			EN_CS_NTC	EN_ITERM_80MA
Bit1	NTC_FAULT[1:0]			RSTD_LAY	SWITCH_MD
Bit0				EN_SHIPMD_0P1S	

ADDR	0x10	0x11	0x4F
NAME	Additional Function Control	Additional Function Control	Additional Function Control
Default	0x00	0x00	0x00
Bit7	Reserve[5:0]	Reserve[2:0]	Reserve[4:0]
Bit6			
Bit5			
Bit4		ITERM_80MA_ST	
Bit3		Reserve[3:0]	M_FSM[3:0]
Bit2			
Bit1	CVST		
Bit0	Reserve		

Awinic Confidential

Input Source Control Register

Address: 00H, Reset State: 1000 1111.

BIT Name	W/R	BIT	SFTRST	WTDRST	Function
VIN_DPM	W/R	B7-B4	Y	N	VIN_DPM voltage regulation setting: BIN VIN_DPM (V) 0000 3.88 1000 4.52 (default) 0001 3.96 1001 4.60 0010 4.04 1010 4.68 0011 4.12 1011 4.76 0100 4.20 1100 4.84 0101 4.28 1101 4.92 0110 4.36 1110 5.00 0111 4.44 1111 5.08
IIN_LIM	W/R	B3-B0	Y	N	Input current limit setting: BIN IIN_LIM (mA) 0000 50 1000 290 0001 80 1001 320 0010 110 1010 350 0011 140 1011 380 0100 170 1100 410 0101 200 1101 440 0110 230 1110 470 0111 260 1111 500(default)

Power On Configuration Register

Address: 01H, Reset State: 1010 1100.

BIT Name	W/R	BIT	SFTRST	WTDRST	Function
t_{RST_DGL}	W/R	B7-B6	Y	Y	Pull INT low time period to disconnect the battery: BIN time (s) 00: 8 01: 12 10: 16(default) 11: 20
t_{RST_DUR}	W/R	B5	Y	Y	Q2 lasts off time before auto-on: 0: 2s; 1: 4s (default).
EN_HIZ	W/R	B4	Y	Y	0: disable (default); 1: enable.
CEB	W/R	B3	Y	Y	0: charge enable; 1: charge disable (default).
VBAT_UVLO	W/R	B2-B0	Y	Y	Battery UVLO Threshold: BIN VBAT_UVLO (V) 000 2.43 100 2.76 (default) 001 2.49 101 2.85 010 2.58 110 2.94 011 2.67 111 3.03

Charge Current Control Register

Address: 02H, Reset State:0000 1111

BIT Name	W/R	BIT	REGRST	WTDRST	Function																																																																																																																																				
REG_RST	W/R	B7	Y	N	0: normal (default); 1: reset.																																																																																																																																				
WD_TMR_RST	W/R	B6	Y	Y	0: normal (default); 1: reset.																																																																																																																																				
ICHG	W/R	B5-B0	Y	Y	Fast charge current setting: <table border="1"> <thead> <tr> <th>BIN</th> <th>ICHG(mA)</th> <th></th> <th></th> </tr> </thead> <tbody> <tr><td>000000</td><td>8</td><td>100000</td><td>264</td></tr> <tr><td>000001</td><td>16</td><td>100001</td><td>272</td></tr> <tr><td>000010</td><td>24</td><td>100010</td><td>280</td></tr> <tr><td>000011</td><td>32</td><td>100011</td><td>288</td></tr> <tr><td>000100</td><td>40</td><td>100100</td><td>296</td></tr> <tr><td>000101</td><td>48</td><td>100101</td><td>304</td></tr> <tr><td>000110</td><td>56</td><td>100110</td><td>312</td></tr> <tr><td>000111</td><td>64</td><td>100111</td><td>320</td></tr> <tr><td>001000</td><td>72</td><td>101000</td><td>328</td></tr> <tr><td>001001</td><td>80</td><td>101001</td><td>336</td></tr> <tr><td>001010</td><td>88</td><td>101010</td><td>344</td></tr> <tr><td>001011</td><td>96</td><td>101011</td><td>352</td></tr> <tr><td>001100</td><td>104</td><td>101100</td><td>360</td></tr> <tr><td>001101</td><td>112</td><td>101101</td><td>368</td></tr> <tr><td>001110</td><td>120</td><td>101110</td><td>376</td></tr> <tr><td>001111</td><td>128 (default)</td><td>101111</td><td>384</td></tr> <tr><td>010000</td><td>136</td><td>110000</td><td>392</td></tr> <tr><td>010001</td><td>144</td><td>110001</td><td>400</td></tr> <tr><td>010010</td><td>152</td><td>110010</td><td>408</td></tr> <tr><td>010011</td><td>160</td><td>110011</td><td>416</td></tr> <tr><td>010100</td><td>168</td><td>110100</td><td>424</td></tr> <tr><td>010101</td><td>176</td><td>110101</td><td>432</td></tr> <tr><td>010110</td><td>184</td><td>110110</td><td>440</td></tr> <tr><td>010111</td><td>192</td><td>110111</td><td>448</td></tr> <tr><td>011000</td><td>200</td><td>111000</td><td>456</td></tr> <tr><td>011001</td><td>208</td><td>111001</td><td>464</td></tr> <tr><td>011010</td><td>216</td><td>111010</td><td>472</td></tr> <tr><td>011011</td><td>224</td><td>111011</td><td>480</td></tr> <tr><td>011100</td><td>232</td><td>111100</td><td>488</td></tr> <tr><td>011101</td><td>240</td><td>111101</td><td>496</td></tr> <tr><td>011110</td><td>248</td><td>111110</td><td>504</td></tr> <tr><td>011111</td><td>256</td><td>111111</td><td>512</td></tr> </tbody> </table>	BIN	ICHG(mA)			000000	8	100000	264	000001	16	100001	272	000010	24	100010	280	000011	32	100011	288	000100	40	100100	296	000101	48	100101	304	000110	56	100110	312	000111	64	100111	320	001000	72	101000	328	001001	80	101001	336	001010	88	101010	344	001011	96	101011	352	001100	104	101100	360	001101	112	101101	368	001110	120	101110	376	001111	128 (default)	101111	384	010000	136	110000	392	010001	144	110001	400	010010	152	110010	408	010011	160	110011	416	010100	168	110100	424	010101	176	110101	432	010110	184	110110	440	010111	192	110111	448	011000	200	111000	456	011001	208	111001	464	011010	216	111010	472	011011	224	111011	480	011100	232	111100	488	011101	240	111101	496	011110	248	111110	504	011111	256	111111	512
BIN	ICHG(mA)																																																																																																																																								
000000	8	100000	264																																																																																																																																						
000001	16	100001	272																																																																																																																																						
000010	24	100010	280																																																																																																																																						
000011	32	100011	288																																																																																																																																						
000100	40	100100	296																																																																																																																																						
000101	48	100101	304																																																																																																																																						
000110	56	100110	312																																																																																																																																						
000111	64	100111	320																																																																																																																																						
001000	72	101000	328																																																																																																																																						
001001	80	101001	336																																																																																																																																						
001010	88	101010	344																																																																																																																																						
001011	96	101011	352																																																																																																																																						
001100	104	101100	360																																																																																																																																						
001101	112	101101	368																																																																																																																																						
001110	120	101110	376																																																																																																																																						
001111	128 (default)	101111	384																																																																																																																																						
010000	136	110000	392																																																																																																																																						
010001	144	110001	400																																																																																																																																						
010010	152	110010	408																																																																																																																																						
010011	160	110011	416																																																																																																																																						
010100	168	110100	424																																																																																																																																						
010101	176	110101	432																																																																																																																																						
010110	184	110110	440																																																																																																																																						
010111	192	110111	448																																																																																																																																						
011000	200	111000	456																																																																																																																																						
011001	208	111001	464																																																																																																																																						
011010	216	111010	472																																																																																																																																						
011011	224	111011	480																																																																																																																																						
011100	232	111100	488																																																																																																																																						
011101	240	111101	496																																																																																																																																						
011110	248	111110	504																																																																																																																																						
011111	256	111111	512																																																																																																																																						

Discharge Current Control Register

Address: 03H, Reset State:1001 0001.

BIT Name	W/R	BIT	REGRST	WDRST	Function					
IDSCHG	W/R	B7-B4	Y	Y	BAT to SYS discharge current limit: BIN IDSCHG(mA)					
					0000 200 1000 1800					
					0001 400 1001 2000 (default)					
					0010 600 1010 2200					
					0011 800 1011 2400					
					0100 1000 1100 2600					
					0101 1200 1101 2800					
					0110 1400 1110 3000					
					0111 1600 1111 3200					
					ITERM	W/R	B3-B0	Y	Y	Termination current. current range: BIN ITERM(mA)
										0000 1 1000 17
										0001 3 (default) 1001 19
0010 5 1010 21										
0011 7 1011 23										
0100 9 1100 25										
0101 11 1101 27										
0110 13 1110 29										
0111 15 1111 31										

Charge Voltage Register

Address: 04H, Reset State:1010 0011.

BIT Name	W/R	BIT	REGRST	WDRST	Function
VBAT_REG	W/R	B7-B2	Y	Y	Battery regulation voltage: BIN VBAT_REG(V)
					000000 3.600 100000 4.080
					000001 3.615 100001 4.095
					000010 3.630 100010 4.110
					000011 3.645 100011 4.125
					000100 3.660 100100 4.140
					000101 3.675 100101 4.155
					000110 3.690 100110 4.170
					000111 3.705 100111 4.185
					001000 3.720 101000 4.200(default)
					001001 3.735 101001 4.215
					001010 3.750 101010 4.230
					001011 3.765 101011 4.245
					001100 3.780 101100 4.260
					001101 3.795 101101 4.275
					001110 3.810 101110 4.290
					001111 3.825 101111 4.305
					010000 3.840 110000 4.320
					010001 3.855 110001 4.335
					010010 3.870 110010 4.350
					010011 3.885 110011 4.365
					010100 3.900 110100 4.380
					010101 3.915 110101 4.395
					010110 3.930 110110 4.410
					010111 3.945 110111 4.425
					011000 3.960 111000 4.440
					011001 3.975 111001 4.455

					011010 3.990 111010 4.470 011011 4.005 111011 4.485 011100 4.020 111100 4.500 011101 4.035 111101 4.515 011110 4.050 111110 4.530 011111 4.065 111111 4.545
VBAT_PRE	W/R	B1	Y	Y	Pre-charge to Fast charge threshold: 0: 2.8V; 1: 3.0V (default).
VRECH	W/R	B0	Y	Y	Battery recharge threshold (below VBAT_REG): 0: 100mV; 1: 200mV (default).

Charger Termination/Timer Control Register

Address: 05H, Reset State:0111 1010.

BIT Name	W/R	BIT	REGRST	WTDRST	Function
EN_WD_DISC HG	W/R	B7	Y	N	Watchdog control in discharge mode: 0: disable (default); 1: enable.
WATCHDOG	W/R	B6-B5	Y	N	Watchdog setting: 00: disable timer 01: 40s 10: 80s 11: 160s (default) If Bit[6:5]=00, then watchdog timer is disable no matter Bit 7 is set or no.
EN_TERM	W/R	B4	Y	Y	Termination Setting (control the termination is allowed or not): 0: disable ; 1: enable (default).
EN_TIMER	W/R	B3	Y	Y	Safety timer Setting: 0: disable; 1: enable (default).
CHG_TMR	W/R	B2-B1	Y	Y	Fast charge timer: 00: 3hrs 01: 5hrs (default); 10: 8hrs 11: 12hrs.
TERM_TMR	W/R	B0	Y	Y	Termination timer Setting (When TERM_TMR is enabled, the device will not suspend the charge current after charge termination): 0: disable (default); 1: enable.

Main Control Register

Address: 06H, Reset State:1100 0000.

BIT Name	W/R	BIT	REGRST	WTDRST	Function
EN_NTC	W/R	B7	Y	Y	0: disable; 1: enable (default).
TMR2X_EN	W/R	B6	Y	Y	0: disable 2x extended safety timer during PPMF; 1: enable 2x extended safety timer during PPMF (default).
FET_DIS	W/R	B5	Y	N	0: enable (default); 1: turn off.
PG_INT_CON TROL	W/R	B4	Y	Y	0: on (default); 1: off.
EOC_INT_CO NTROL	W/R	B3	Y	Y	0: on (default); 1: off. (EOC: End of Charge)

CHG STATUS_INT_CONTROL	W/R	B2	Y	Y	0: on (default); 1: off.
NTC_INT_CONTROL	W/R	B1	Y	Y	0: on (default); 1: off.
BATOVP_INT_CONTROL	W/R	B0	Y	Y	0: on (default); 1: off.

System Voltage Control Register

Address: 07H, Reset State:0011 1000.

BIT Name	W/R	BIT	REGRST	WTDRST	Function
DIS_PCB_OTP	W/R	B7	Y	Y	PCB OTP Disable. 0: enable PCB OTP (default); 1: disable PCB OTP.
DIS_VINLOOP	W/R	B6	Y	Y	VIN_DPM loop. 0: enable VIN_DPM loop (default); 1: disable.
TJ_REG	W/R	B5-B4	Y	Y	Thermal regulation threshold: BIN Temperature(°C) 00 60 01 80 10 100 11 120 (default)
VSYS_REG	W/R	B3-B0	Y	N	System voltage regulation. Range: BIN VSYS_REG(V) 0000 4.20 1000 4.60 (default) 0001 4.25 1001 4.65 0010 4.30 1010 4.70 0011 4.35 1011 4.75 0100 4.40 1100 4.80 0101 4.45 1101 4.85 0110 4.50 1110 4.90 0111 4.55 1111 4.95

System Status Register

Address: 08H, Reset State:0110 0000.

BIT Name	W/R	BIT	REG RST	WTDRST	Function
Watchdog_Fault	RC	B7	NA	NA	0: normal (default); 1: watchdog timer expiration.
REV_ID	R	B6-B5	NA	NA	Revision ID 10: 32001 11: 32012A (default);
CHG_STAT	R	B4-B3	NA	NA	00: not charging (default); 01: pre charge; 10: charge; 11: charge done.
VIN_DPM_STAT	R	B2	NA	NA	0: no DPM (default); 1: in DPM.
PG_STAT	R	B1	NA	NA	0: Power fail (default); 1: Power good.
THERM_STAT	R	B0	NA	NA	0: no thermal regulation (default); 1: in thermal regulation.

Fault Register

Address: 09H, Reset State:0100 0000.

BIT Name	W/R	BIT	REGRST	WTDRST	Function
EN_SHIPPING_DGL	W/R	B7-B6	Y	N	Enter shipping mode deglitch time: BIN deglitch time(s) 00: 0.1 01: 1(default); 10: 4 11: 8
VIN_FAULT	RC	B5	NA	NA	0: normal (default); 1: input fault (OVP or bad source).
THEM_SD	RC	B4	NA	NA	0: normal (default); 1: thermal shutdown.
BAT_FAULT	RC	B3	NA	NA	0: normal (default); 1: battery OVP.
STMR_FAULT	RC	B2	NA	NA	0: normal (default); 1: safety timer expiration.
NTC_FAULT[1]	R	B1	NA	NA	0: normal (default); 1: NTC hot.
NTC_FAULT[0]	R	B0	NA	NA	0: normal (default); 1: NTC cold.

Address Register

Address: 0AH, Reset State:0100 1001.

BIT Name	W/R	BIT	REGRST	WTDRST	Function
CHIP ID	R	B7-B0	N	N	Chip ID used to be identified

Individual Charge Register

Address: 0BH, Reset State:0100 0011.

BIT Name	W/R	BIT	REGRST	WTDRST	Function
EN_ICHG_DIVD	W/R	B7	Y	Y	0: keep the current value of REG02[5:0] configuration. (default). 1: reduce the current value of REG02[3:0] configuration to 1/4;
EN_TREG	W/R	B6	Y	Y	Thermal regulation enable 0: disable 1: enable (default).
EN_IPRE_SET	W/R	B5	Y	Y	0: IPRE is set by REG03[3:0] (default); 1: IPRE is set by REG0B[4:1].
IPRE[3:0]	W/R	B4-B1	Y	Y	1mA~31mA pre-charge current configuration: 2 mA/step, 3mA (default). BIN IPRE(mA) 0000 1 1000 17 0001 3(default) 1001 19 0010 5 1010 21 0011 7 1011 23 0100 9 1100 25 0101 11 1101 27 0110 13 1110 29 0111 15 1111 31
EN_SHIPMD_0 P1S	W/R	B0	Y	Y	VIN Plug: In deglitch time of shipping mode out: 0: 2s; 1: 100ms(default).

Additional Function Control Register0

Address: 0CH, Reset State:0000 0000.

BIT Name	W/R	BIT	REGRST	WTDRST	Function
EN0P55	W/R	B7	Y	Y	Increase input current limit: 0: The input current limit is set by REG00[3:0] (default); 1: If REG00[3:0]=1111,this bit increase the input current limit to 550mA, otherwise, it is useless.
ITERMDEG	W/R	B6	Y	Y	Charge termination current deglitch time: 0: 3s (default); 1: 200ms.
Reserve	NA	B5~B4	NA	NA	NA
PRETO	W/R	B3	Y	Y	0: Pre-charge timeout is 1h (default); 1: Pre-charge timeout is 2h.
DIS_SHIPINT	W/R	B2	Y	N	The function of disabling INT PIN during SHIPPING mode: 0: Normal INT PIN function(Default); 1: Disable INT PIN function during SHIPPING mode.
EN_CS_NTC	NA	B1	NA	NA	Enable current sourcing NTC: 0: Disable (default); 1: Enable.
RSTDLAY	W/R	B0	Y	Y	The additional time of Pull INT low to disconnect the battery: 0: 0s (default); 1: 2s.

Additional Function Control Register1

Address: 0DH, Reset State:0000 0000.

BIT Name	W/R	BIT	REGRST	WTDRST	Function
Reserve	NA	B7-B6	NA	NA	NA
VIN_OVP	W/R	B5	Y	N	VIN OVP threshold voltage 0: 6V (default); 1: 7.5V.
Reserve	NA	B4	NA	NA	NA
RCH_THCTR	W/R	B3	Y	N	Halve Recharge voltage threshold 0: 100/200mV (default); 1: 50/100mV.
INT100MS	W/R	B2	Y	N	INT 100ms exit ship mode 0: 2s (default); 1: 100ms.
EN_80MA_DET	W/R	B1	Y	N	Enable 80mA Charge current detect 0: Disable (default); 1: Enable.
SWITCH_MD	W/R	B0	Y	N	Enable switch mode 0: Disable (default); 1: Enable.

Additional Function Control Register2

Address: 10H, Reset State:0000 0000.

BIT Name	W/R	BIT	REGRST	WTDRST	Function
Reserve	NA	B7-B2	NA	NA	NA
CVST	R	B1	NA	NA	0: Not in CV state (default); 1: In CV state.
Reserve	NA	B0	NA	NA	NA

Additional Function Control Register3

Address: 11H, Reset State:0000 0000.

BIT Name	W/R	BIT	REGRST	WTDRST	Function
Reserve	NA	B7-B5	NA	NA	NA
BELOW_80MA_ST	R	B4	NA	NA	Valid when REG0DH[1]=1 0: Charge current is over 80mA (default); 1: Charge current is below 80mA.
Reserve	NA	B3-B0	NA	NA	NA

Additional Function Control Register4

Address: 4FH, Reset State:0000 0000.

BIT Name	W/R	BIT	REGRST	WTDRST	Function
Reserve	NA	B7-B3	NA	NA	NA

M_FSM	R	B2-B0	NA	NA	Main fsm 00: Start(default) 001: Discharge 010: Charge 011: Only Power System 100: Shipping mode
-------	---	-------	----	----	--

Awinic Confidential

Application Information

NTC FUNCTION

NTC pin is connected to the thermistor paralleled with a resistor R_{F2} to ground. Another resistor R_{F1} is connected to the VDD which is the chip's internal power supply voltage. The high temperature limit and low temperature limit can be varied by using different R_{F1} and R_{F2} . Illustrated in Figure 16, the off chip resistors must be connected as the blue part demonstrated. The resistance of R_{F1} and R_{F2} can be calculated by Equation (1) and Equation (2):

$$R_{F2} = \frac{(V_{COLD} - V_{HOT}) \times R_{NTCH} \times R_{NTCL}}{(V_{HOT} - V_{COLD} \times V_{HOT}) \times R_{NTCL} - (V_{COLD} - V_{COLD} \times V_{HOT}) \times R_{NTCH}} \quad (1)$$

$$R_{F1} = \frac{1 - V_{COLD}}{V_{COLD}} \times (R_{F2} // R_{NTCL}) \quad (2)$$

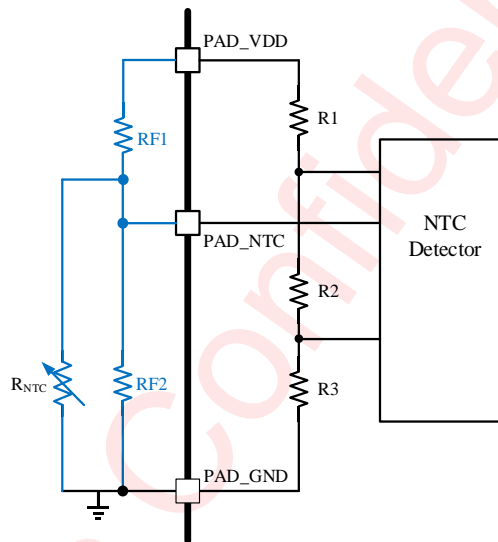

Figure 28 NTC Function(resistor-divided mode)

Where R_{NTCH} is the value of the NTC resistor at the high limit temperature, while the R_{NTCL} is the value of the NTC resistor at a low temperature limit.

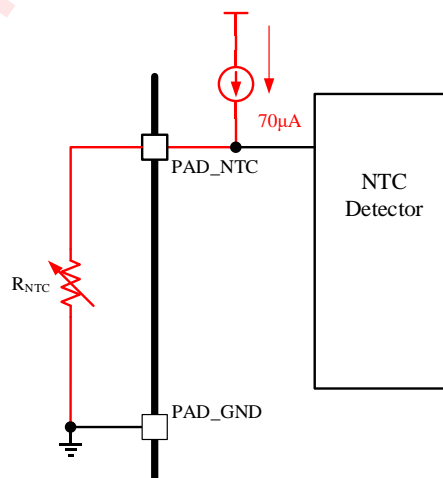

Figure 29 NTC Function(current sourcing mode)

When the register REG0CH[1] is set to 1, the NTC function works in current sourcing mode. In this mode, as demonstrated in Figure 30, a 70 μ A output current is generated from PAD_NTC, the high temperature limit and low temperature limit are determined by the thermal resistance coefficient of NTC resistor. The internal temperature thresholds are designed for 10k Ω NTC resistor, which aimed at 0 $^{\circ}$ C low temperature limit and 50 $^{\circ}$ C high temperature limit typically.

External Capacitor

The external capacitor cannot be absent for the operation of AW32012A. Carefully selecting suitable capacitor is important to guarantee the AW32012A working perfectly on the space limited board.

A 4.7 μ F ceramic capacitor with high level voltage endurance (at least 30V) between IN and GND is recommended. This capacitor rejects input power supply ripple and enhance the stability of DPM loop.

A 1 μ F ceramic capacitor is required between the VDD and GND to maintain internal power supply voltage higher than the POR threshold. Without this capacitor, the chip logic block may work abnormally when working state changes.

Connect a ceramic capacitor between SYS and GND with least capacitance of 4.7 μ F to guarantee the stability of the system power supply loop. Larger capacitor will further reduce the system output's overshoot and undershoot.

A least 4.7 μ F ceramic capacitor is also needed between BAT and GND for some application.

Table 6: Recommended external capacitors

Comments	Capacitor	Supplier	Description	ELA Size	Effective Capacitance
C _{IN}	4.7 μ F	Any	Ceramic Capacitor;50V; X5R or X7R	0603	>2 μ F
C _{VDD}	1 μ F	Any	Ceramic Capacitor;16V; X5R or X7R	0603	>500nF
C _{SYS}	4.7 μ F	Any	Ceramic Capacitor;16V; X5R or X7R	0603	>3 μ F
C _{BAT}	4.7 μ F	Any	Ceramic Capacitor;16V; X5R or X7R	0603	>3 μ F

Tape and Reel Information

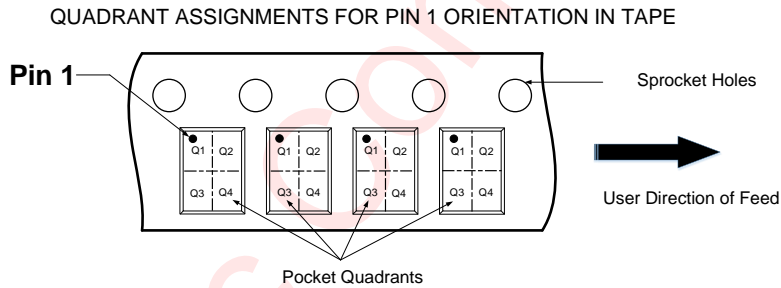
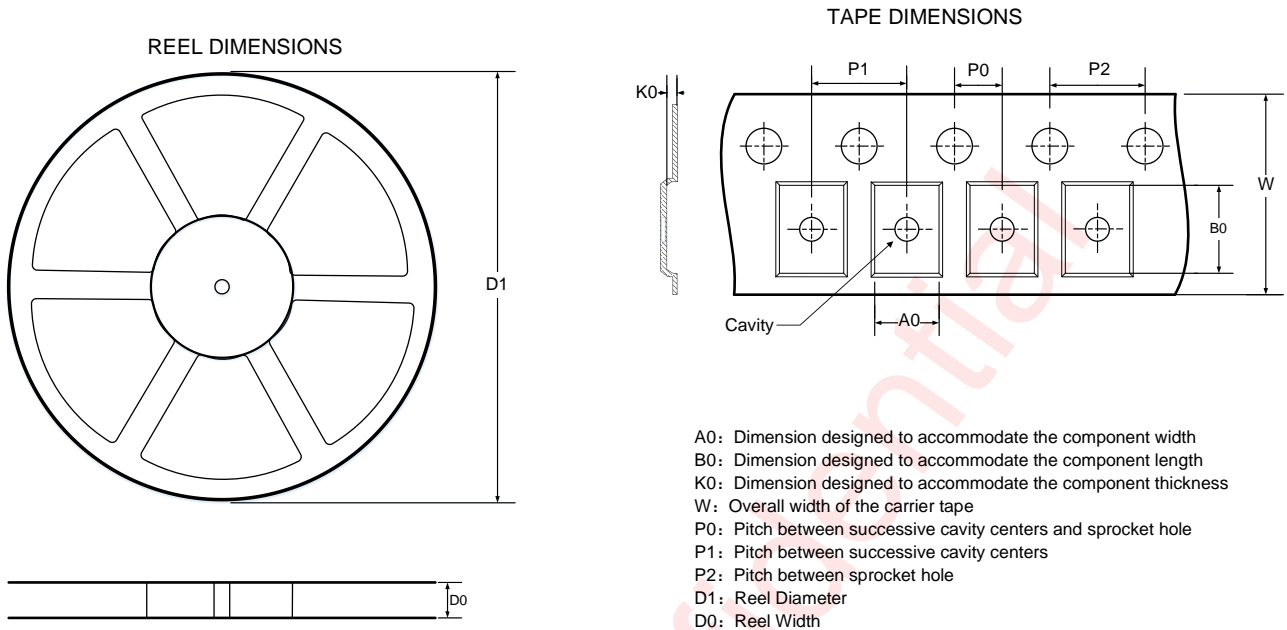

Note: The above picture is for reference only. Please refer to the value in the table below for the actual size

DIMENSIONS AND PIN1 ORIENTATION

D1 (mm)	D0 (mm)	A0 (mm)	B0 (mm)	K0 (mm)	P0 (mm)	P1 (mm)	P2 (mm)	W (mm)	Pin1 Quadrant
180	8.6	1.52	1.52	0.78	2	4	4	8	Q1

All dimensions are nominal

Package Description(POD)

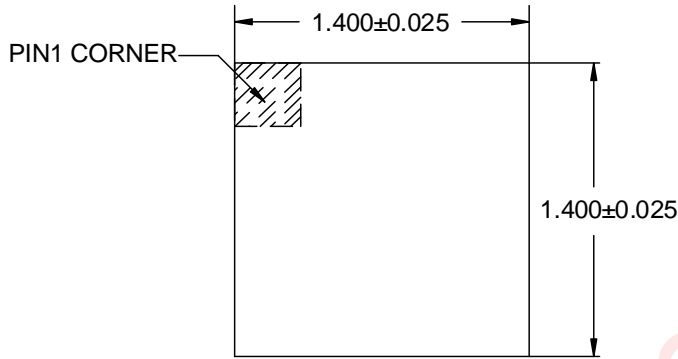

Top View

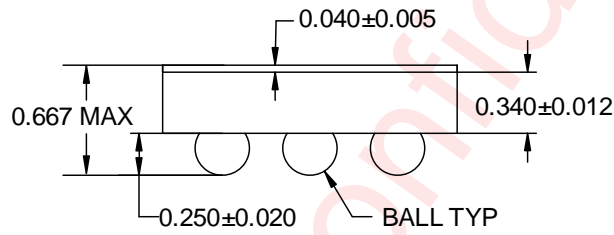

Side View



Bottom View

Unit: mm

Land Pattern Data

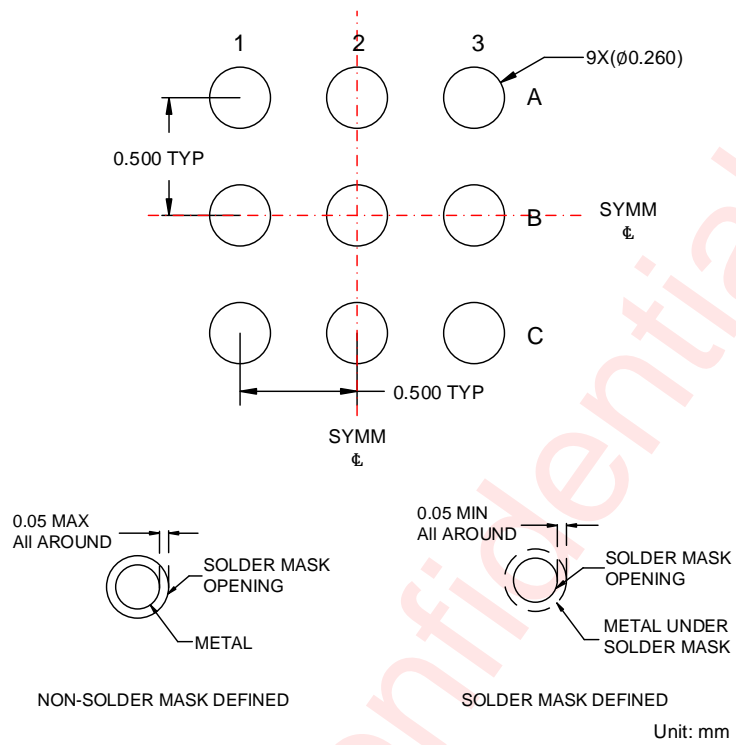

Revision History

Version	Date	Change Record
V1.0	Nov. 2024	Official Released
V1.1	Jan. 2026	Changed the absolute minimum voltage of IN from -2V to -5V

Awinic Confidential

Disclaimer

Information in this document is believed to be accurate and reliable. However, Shanghai AWINIC Technology Co., Ltd (AWINIC Technology) does not give any representations or warranties, expressed or implied, as to the accuracy or completeness of such information and shall have no liability for the consequences of use of such information.

AWINIC Technology reserves the right to make changes to information published in this document, including without limitation specifications and product descriptions, at any time and without notice. Customers shall obtain the latest relevant information before placing orders and shall verify that such information is current and complete. This document supersedes and replaces all information supplied prior to the publication hereof.

AWINIC Technology products are not designed, authorized or warranted to be suitable for use in medical, military, aircraft, space or life support equipment, nor in applications where failure or malfunction of an AWINIC Technology product can reasonably be expected to result in personal injury, death or severe property or environmental damage. AWINIC Technology accepts no liability for inclusion and/or use of AWINIC Technology products in such equipment or applications and therefore such inclusion and/or use is at the customer's own risk.

Applications that are described herein for any of these products are for illustrative purposes only. AWINIC Technology makes no representation or warranty that such applications will be suitable for the specified use without further testing or modification.

All products are sold subject to the general terms and conditions of commercial sale supplied at the time of order acknowledgement.

Nothing in this document may be interpreted or construed as an offer to sell products that is open for acceptance or the grant, conveyance or implication of any license under any copyrights, patents or other industrial or intellectual property rights.

Reproduction of AWINIC information in AWINIC data books or data sheets is permissible only if reproduction is without alteration and is accompanied by all associated warranties, conditions, limitations, and notices. AWINIC is not responsible or liable for such altered documentation. Information of third parties may be subject to additional restrictions.

Resale of AWINIC components or services with statements different from or beyond the parameters stated by AWINIC for that component or service voids all express and any implied warranties for the associated AWINIC component or service and is an unfair and deceptive business practice. AWINIC is not responsible or liable for any such statements.