

AW9548 8-Channel I²C-bus Switch With Reset

Features

- 1-to-8 bidirectional translating switches
- I²C bus and SMBus compatible
- Active-low reset input
- Three address pins, allowing up to eight AW9548 devices on the I²C bus
- Channel selection through an I²C bus, in any combination
- Power up with all switch channels deselected
- Low R_{ON} switches
- 400kHz I²C interface
- Allows voltage-level translation between 1.8V, 2.5V, 3.3V and 5V buses
- 1.65V~5.5V power supply
- 5.5V tolerant inputs
- No glitch on power up
- Supports hot insertion
- Low standby current
- Package
 - AW9548TSR: TSSOP-24L
 - AW9548QNR: QFN 4X4-24L

Applications

- Servers
- Routers (telecom switching equipment)
- Factory Automation
- Products with I²C slave address conflicts (such as multiple, identical temperature sensors)

General Description

The AW9548 is an 8-channel, bidirectional translating switch that can be controlled through the I²C bus. The SCL/SDA upstream pair fans out to eight downstream pairs, or channels. Any individual SC_n/SD_n channel or combination of channels can be selected, determined by the contents of the programmable control register.

The device offers an active-low RESETN input which resets the state machine and allows the AW9548 to recover from a situation where one of the downstream I²C buses get stuck in a low state. The state machine of the device can also be reset by cycling the power supply, V_{CC}, also known as a power-on reset (POR). Both the RESETN function and a POR cause all channels to be deselected and initializes the I²C/SMBus state machine.

The pass-gate transistors of the AW9548 are constructed so that the V_{CC} pin can be used to limit the maximum high voltage which is passed by the AW9548. Limiting the maximum high voltage allows the use of different bus voltages on each pair, so that 1.8V or 2.5V or 3.3V parts can communicate with 5V parts without any additional protection. External pull-up resistors pull the bus up to the desired voltage level for each channel. All I/O pins are 5.5V tolerant.

Typical Application Circuit

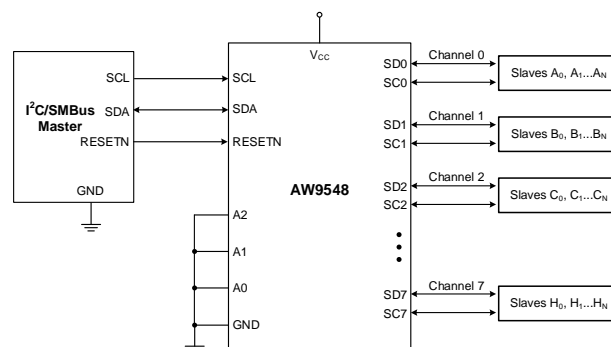
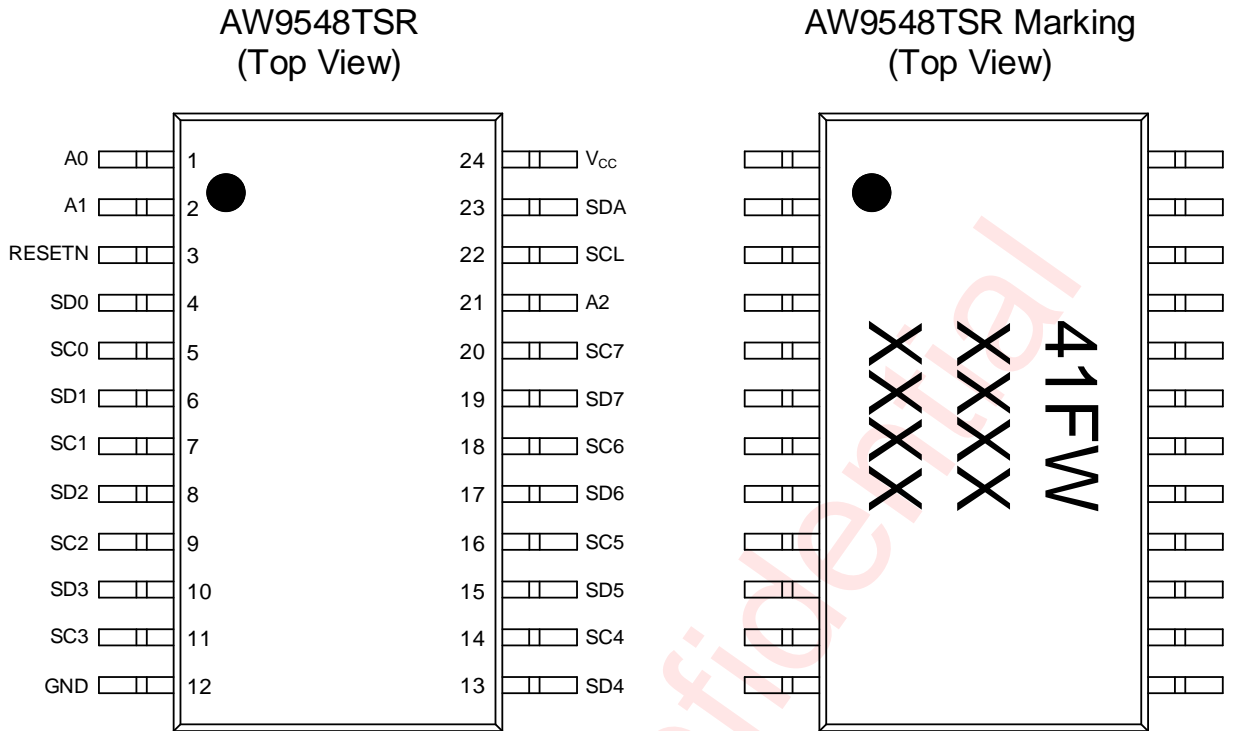
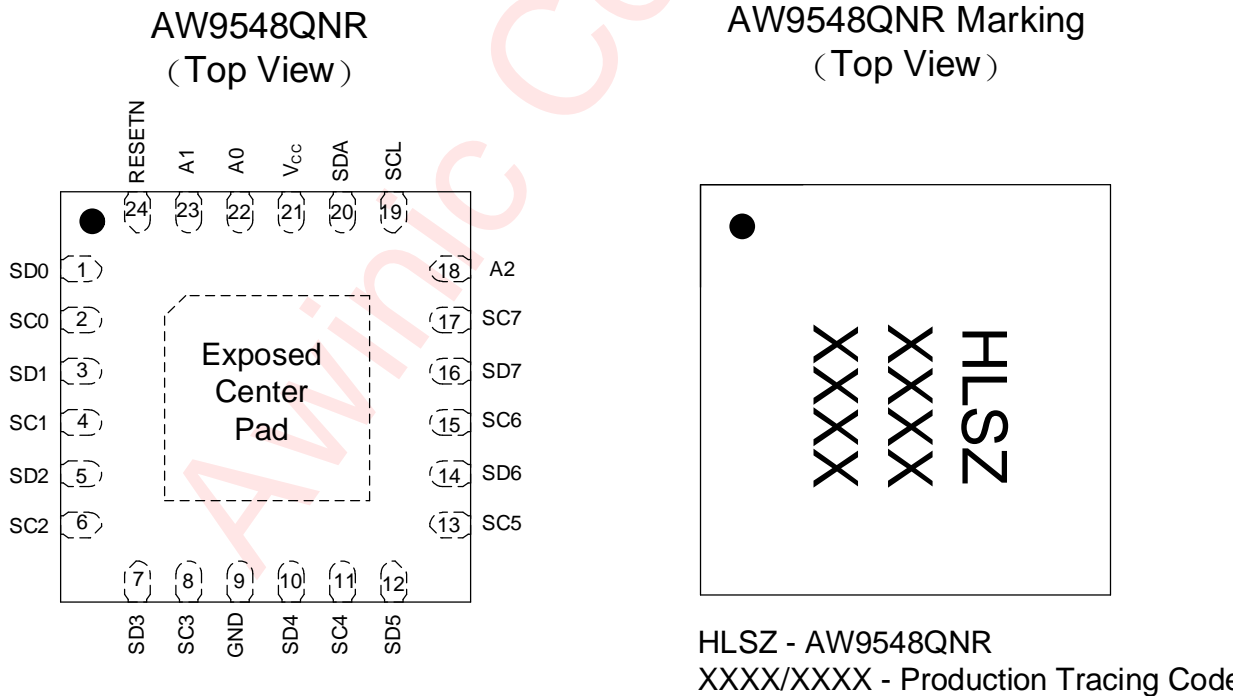

Figure 1 AW9548 Simplified Application Circuit

Pin Configuration And Top Mark



41FW- AW9548TSR
XXXX/XXXX- Production Tracing Code



HLSZ - AW9548QNR
XXXX/XXXX - Production Tracing Code

Figure 2 Pin Configuration and Marking

Pin Definition

Name	Pin No.		Description
	AW9548TSR	AW9548QNR	
A0	1	22	Address input 0. Connect directly to V _{CC} or ground.
A1	2	23	Address input 1. Connect directly to V _{CC} or ground.
RESETN	3	24	Active-low reset input. Connect to V _{CC} or V _{DPUM} ^(NOTE1) through a pull-up resistor, if not used.
SD0	4	1	Serial data 0. Connect to V _{DPU0} ^(NOTE1) through a pull-up resistor.
SC0	5	2	Serial clock 0. Connect to V _{DPU0} ^(NOTE1) through a pull-up resistor.
SD1	6	3	Serial data 1. Connect to V _{DPU1} ^(NOTE1) through a pull-up resistor.
SC1	7	4	Serial clock 1. Connect to V _{DPU1} ^(NOTE1) through a pull-up resistor.
SD2	8	5	Serial data 2. Connect to V _{DPU2} ^(NOTE1) through a pull-up resistor.
SC2	9	6	Serial clock 2. Connect to V _{DPU2} ^(NOTE1) through a pull-up resistor.
SD3	10	7	Serial data 3. Connect to V _{DPU3} ^(NOTE1) through a pull-up resistor.
SC3	11	8	Serial clock 3. Connect to V _{DPU3} ^(NOTE1) through a pull-up resistor.
GND	12	9	Ground.
SD4	13	10	Serial data 4. Connect to V _{DPU4} ^(NOTE1) through a pull-up resistor.
SC4	14	11	Serial clock 4. Connect to V _{DPU4} ^(NOTE1) through a pull-up resistor.
SD5	15	12	Serial data 5. Connect to V _{DPU5} ^(NOTE1) through a pull-up resistor.
SC5	16	13	Serial clock 5. Connect to V _{DPU5} ^(NOTE1) through a pull-up resistor.
SD6	17	14	Serial data 6. Connect to V _{DPU6} ^(NOTE1) through a pull-up resistor.
SC6	18	15	Serial clock 6. Connect to V _{DPU6} ^(NOTE1) through a pull-up resistor.
SD7	19	16	Serial data 7. Connect to V _{DPU7} ^(NOTE1) through a pull-up resistor.
SC7	20	17	Serial clock 7. Connect to V _{DPU7} ^(NOTE1) through a pull-up resistor.
A2	21	18	Address input 2. Connect directly to V _{CC} or ground.
SCL	22	19	Serial clock bus. Connect to V _{DPUM} ^(NOTE1) through a pull-up resistor.
SDA	23	20	Serial data bus. Connect to V _{DPUM} ^(NOTE1) through a pull-up resistor.
V _{CC}	24	21	Supply voltage.

NOTE1: V_{DPUX} is the pull-up reference voltage for the associated data line. V_{DPUM} is the master I²C reference voltage and V_{DPU0}~V_{DPU7} are the slave channel reference voltages.

Functional Block Diagram

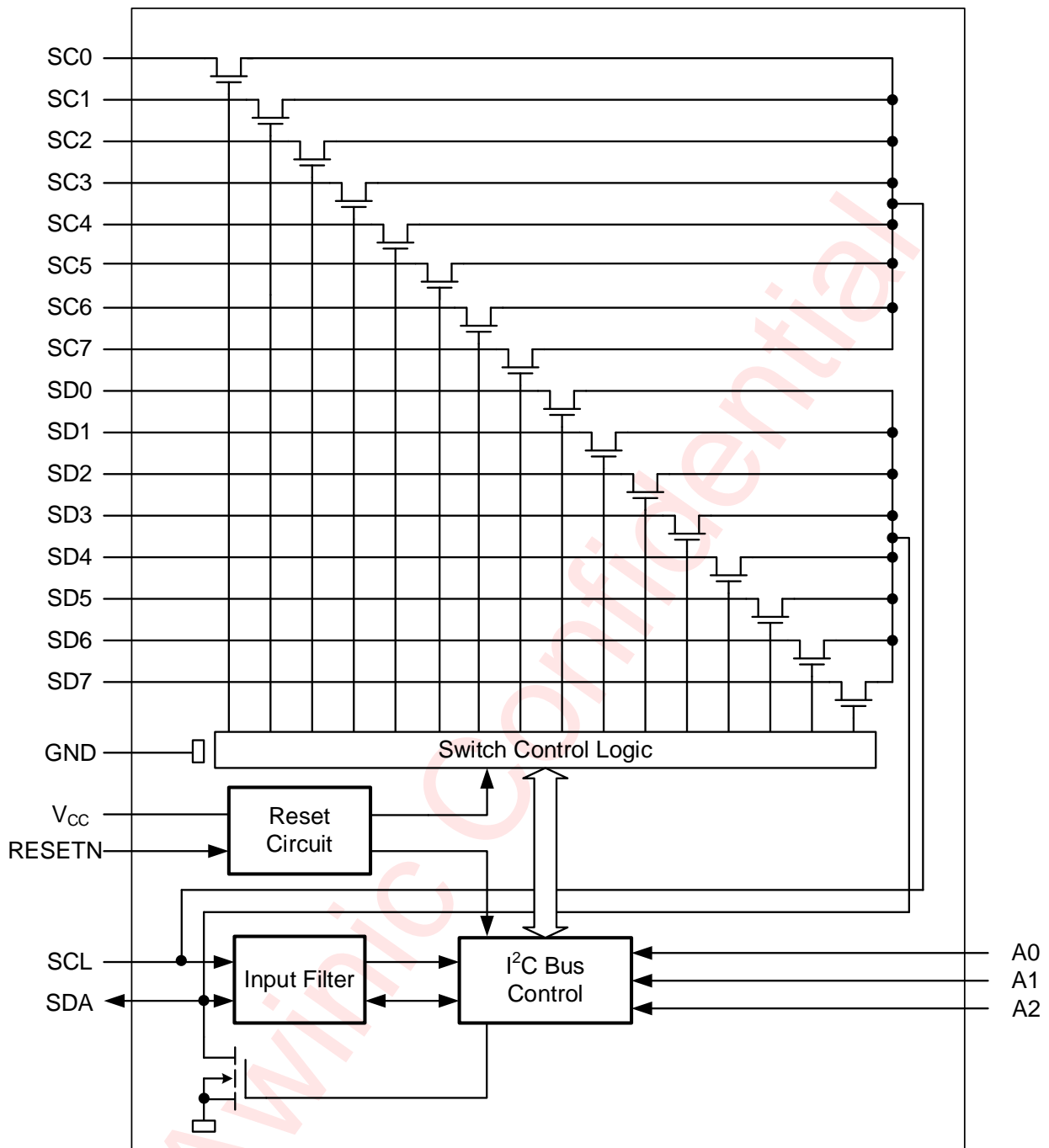

Figure 3 Functional Block Diagram

Ordering Information

Part Number	Temperature	Package	Marking	Moisture Sensitivity Level	Environmental Information	Delivery Form
AW9548TSR	-40°C~125°C	TSSOP-24L	41FW	MSL1	RoHS+HF	3000 units/ Tape and Reel
AW9548QNR	-40°C~125°C	QFN 4X4-24L	HLSZ	MSL2	RoHS+HF	3000 units/ Tape and Reel

Absolute Maximum Ratings^(NOTE2)

PARAMETERS	RANGE
Supply voltage V_{CC}	-0.5V to 7.0V
Input voltage V_I	-0.5V to 7.0V
Input current I_I	-20mA to 20mA
Output current I_O	-25mA to 25mA
Supply current I_{CC}	-100mA to 100mA
Operating free-air temperature range T_A	-40°C to 125°C
Storage temperature T_{STG}	-65°C to 150°C
Lead temperature (soldering 10 seconds)	260°C
Maximum operating junction temperature T_{JMAX}	150°C
ESD(Including HBM CDM) ^(NOTE3)	
HBM	±4kV
CDM	±1.5kV
Latch-Up	
Test condition: according to JEDEC78E	+IT: 300mA -IT: -300mA

NOTE2: Conditions out of those ranges listed in "absolute maximum ratings" may cause permanent damages to the device. In spite of the limits above, functional operation conditions of the device should within the ranges listed in "recommended operating conditions". Exposure to absolute-maximum-rated conditions for prolonged periods may affect device reliability.

NOTE3: The HBM test method: ESDA/JEDEC JS-001-2017, the CDM test method: ESDA/JEDEC JS-002-2018.

Recommended Operating Conditions

Symbol	Parameter	Min.	Typ.	Max.	Unit
V_{CC}	Supply voltage	1.65		5.5	V
V_{IH}	High-level input voltage	SCL, SDA	$0.7 \times V_{CC}$	6	V
		A2-A0, RESETN	$0.7 \times V_{CC}$	6	V
V_{IL}	Low-level input voltage	SCL, SDA	-0.5	$0.3 \times V_{CC}$	V
		A2-A0, RESETN	-0.5	$0.3 \times V_{CC}$	V

T_A	Operating free-air temperature	$V_{CC}=1.65V$ to 5.5V	-40		125	$^{\circ}C$
-------	--------------------------------	------------------------	-----	--	-----	-------------

Electrical Characteristics

$V_{CC}=1.65V$ to 5.5V, $T_A=25^{\circ}C$ for typical values (unless otherwise noted).

Parameters		Test Condition	V_{CC}	Min.	Typ.	Max.	Unit	
V_{PORR}	Power-on reset voltage, V_{CC} rising	No load, $V_I=V_{CC}$ or GND ^(NOTE4)	1.65V to 5.5V		1.25	1.5	V	
V_{PORF}	Power-on reset voltage, V_{CC} falling	No load, $V_I=V_{CC}$ or GND ^(NOTE4)		0.8	1.05		V	
$V_{O(SW)}$	Switch output voltage	$V_{I(SW)}=V_{CC}$, $I_{SWout}=-100\mu A$	5V		3.2		V	
			4.5V to 5.5V	2.6		4	V	
			3.3V		1.9		V	
			3V to 3.6V	1.5		2.3	V	
			2.5V		1.3		V	
			2.3V to 2.7V	1		1.6	V	
			1.8V		0.7		V	
I_{OL}	SDA	$V_{OL}=0.4V$	1.65V to 2V	15			mA	
			2V to 5.5V	20			mA	
I_I	SCL, SDA	$V_I=V_{CC}$ or GND ^(NOTE4)	1.65V to 5.5V	-1		1	μA	
	A2-A0, RESETN			-1		1	μA	
	SC7-SC0, SD7-SD0			-1		1	μA	
I_{CC}	Active mode	$f_{SCL}=400kHz$	$V_I=V_{CC}$ or GND ^(NOTE4) , $I_O=0$	1.65V		3.9	8	μA
				2.7V		8	15	μA
				3.6V		13	25	μA
				5.5V		26	50	μA
	Active mode	$f_{SCL}=100kHz$	$V_I=V_{CC}$ or GND ^(NOTE4) , $I_O=0$	1.65V		1.2	3	μA
				2.7V		2.5	5	μA
				3.6V		4	10	μA
				5.5V		8	20	μA
	Standby mode	Low and high inputs	$V_I=V_{CC}$ or GND ^(NOTE4) , $I_O=0$	1.65V		0.4	1	μA
				2.7V		0.7	1.5	μA
				3.6V		1	2	μA
				5.5V		1.5	3	μA
ΔI_{CC}	Supply-current change	SCL or SDA input at 0.6V, other inputs at V_{CC} or GND ^(NOTE4)	1.65V to 5.5V		1.5	15	μA	

Parameters		Test Condition	V _{CC}	Min.	Typ.	Max.	Unit
		SCL or SDA input at V _{CC} -0.6V, other inputs at V _{CC} or GND ^(NOTE4)			1.5	15	μA
R _{ON}	Switch-on resistance	V _O =0.4V, I _O =15mA	4.5V to 5.5V	4	8	20	Ω
			3V to 3.6V	5	10	25	Ω
		V _O =0.4V, I _O =10mA	2.3V to 2.7V	8	15	30	Ω
			1.65V to 1.95V	14	25	50	Ω
C _i	A2-A0	V _I =V _{CC} or GND ^(NOTE4)	1.65V to 5.5V		4	5	pF
	RESETN				4	5	pF
C _{io(off)}	SCL, SDA	V _I =V _{CC} or GND ^(NOTE4) , Switch OFF	1.65V to 5.5V		26	34	pF
	SC7-SC0, SD7-SD0				5.5	7.5	pF

NOTE4: RESETN=V_{CC} (held high) when all other input voltages, V_I = GND.

I²C Interface Timing Requirements

Parameters		Standard Mode		Fast Mode		Unit
		Min	Max	Min	Max	
f _{SCL}	Interface clock frequency	0	100	-	400	kHz
t _{HD:STA}	(Repeat-start) START condition hold time	4		0.6	-	μs
t _{LOW}	Low level width of SCL	4.7		1.3	-	μs
t _{HIGH}	High level width of SCL	4		0.6	-	μs
t _{SU:STA}	(Repeat-start) START condition setup time	4.7		0.6	-	μs
t _{HD:DAT}	Data hold time	0		0	-	μs
t _{SU:DAT}	Data setup time	0.25		0.1	-	μs
t _R	Rising time of SDA and SCL		1000	20+0.1C _b	300	ns
t _F	Falling time of SDA and SCL		300	20+0.1C _b	300	ns
t _{SU:STO}	STOP condition setup time	4		0.6	-	μs
t _{BUF}	Time between start and stop condition	4.7		1.3	-	μs
t _{SP}	Pulse width of spikes that must be suppressed by the input filter		50		50	ns
t _{VD:DAT}	Valid-data time (high to low) ^(NOTE5)	SCL low to SDA output low valid	1		1	μs
	Valid-data time (low to high) ^(NOTE5)	SCL low to SDA output high valid	0.6		0.6	μs
t _{VD:ACK}	Valid-data time of ACK condition	ACK signal from SCL low to SDA output low	1		1	μs
C _b	Capacitive load for each bus line		400		400	pF

NOTE5: Data taken using a 1kΩ pull-up resistor and 50pF load.

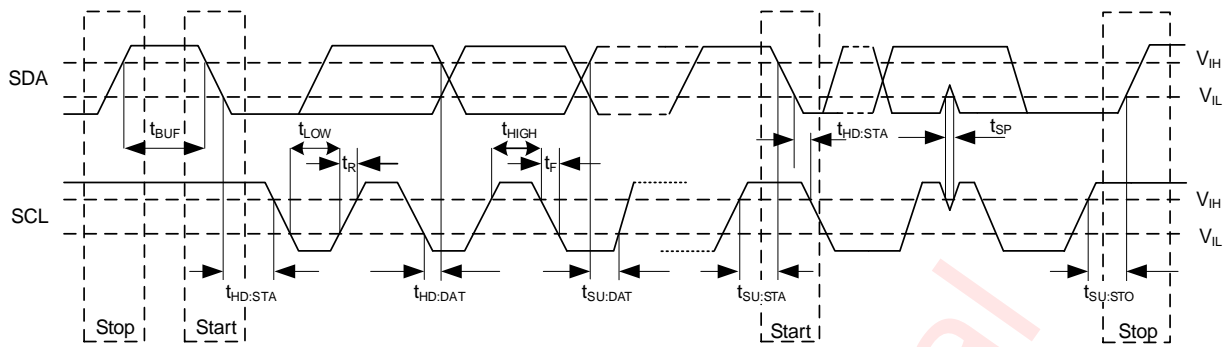

Figure 4 Definition of Timing on The I²C-bus

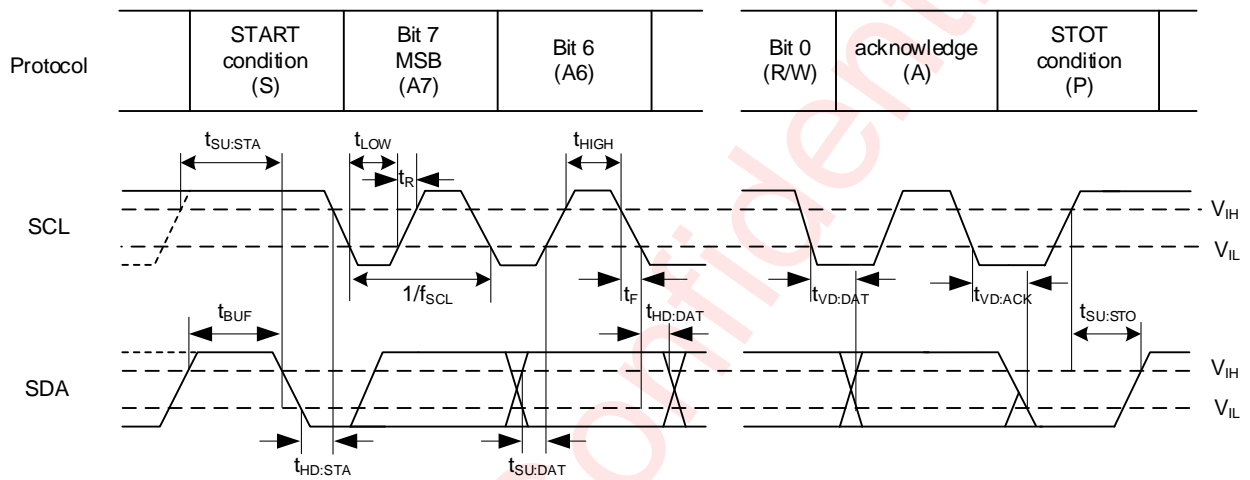

Figure 5 I²C-bus Timing Diagram

Reset Timing Requirements

Symbol	Parameter	Min.	Max.	Unit
$t_{W(rst)L}$	Low-level reset time	6		ns
$T_{REC:STA}$	Recovery time from RESETN to start	0		ns

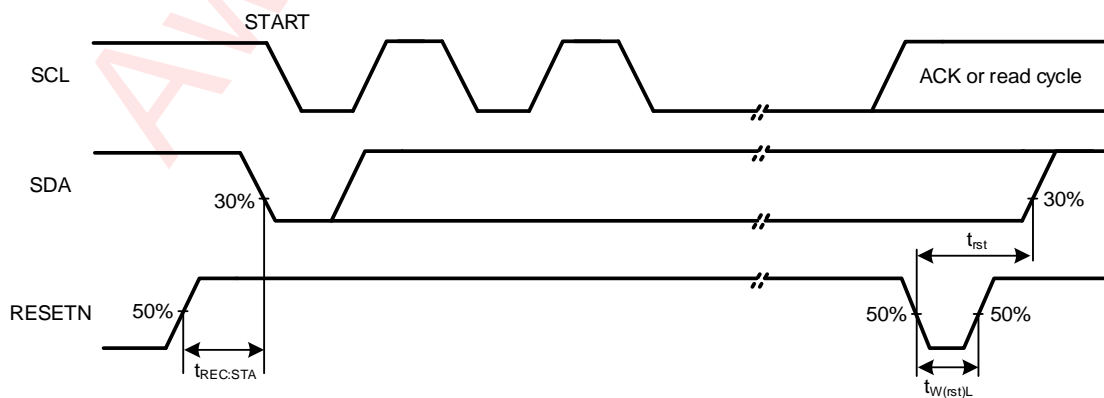

Figure 6 Definition of RESETN Timing

Switching Characteristics

Symbol	Parameter		From (Input)	To (Output)	Min.	Max.	Unit
$t_{pd(NOTE6)}$	Propagation delay time	$R_{ON}=20\Omega$ $C_L=15pF$	SDA or SCL	SDn or SCn		0.3	ns
		$R_{ON}=20\Omega$ $C_L=50pF$				1	ns
$t_{rst(NOTE7)}$	RESETN time (SDA clear)		RESETN	SDA		500	ns

NOTE6: The propagation delay is the calculated RC time constant of the typical ON-state resistance of the switch and the specified load capacitance, when driven by an ideal voltage source (zero output impedance).

NOTE7: t_{rst} is the propagation delay measured from the time the RESET pin is first asserted low to the time the SDA pin is asserted high, signaling a stop condition. It must be a minimum of $t_{W(rst)L}$.

Typical Characteristics

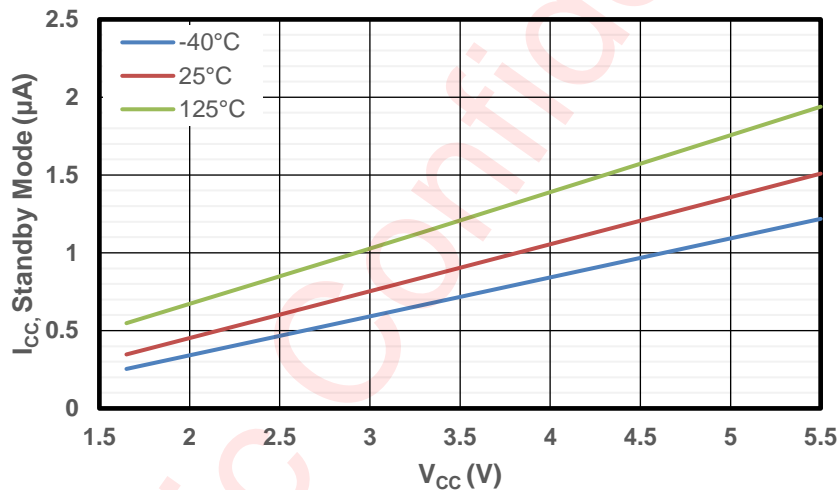

Figure 7 Standby Current (I_{CC}) vs Supply Voltage (V_{CC}) at Three Temperature Points

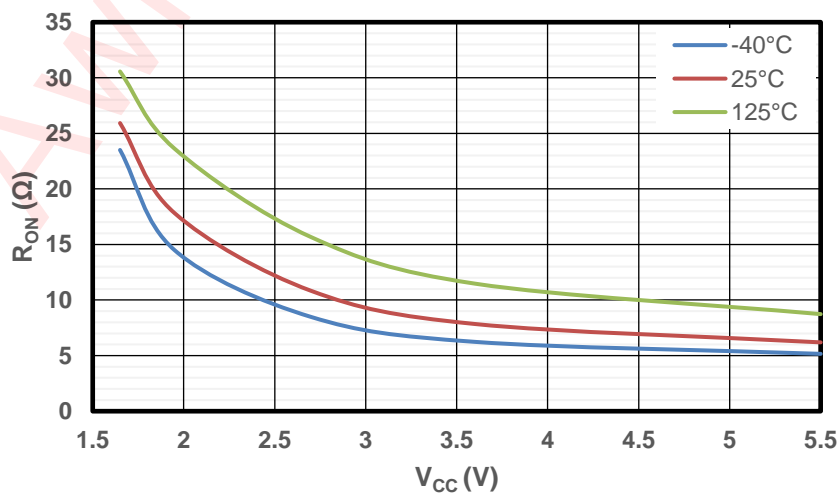

Figure 8 On-Resistance (R_{ON}) vs Supply Voltage (V_{CC}) at Three Temperatures

Detailed Functional Description

The AW9548 is a 8-channel bidirectional transfer switch used for I²C bus that supports standard mode (100kHz) and fast mode (400kHz). The AW9548 has I²C control function and uses a single 8-bit control register, in which each bit controls the enable and disable of the corresponding switch channel for I²C data flow.

The connections of the I²C data path are controlled by the same I²C master device that is switched to communicate with multiple I²C slaves. After the successful acknowledgment of the slave address (hardware selectable by A0, A1 and A2 pins), a single 8-bit control register is written to or read from to determine the selected channels.

AW9548 can also be used for voltage conversion of the I²C bus, allowing 1.8V, 2.5V or 3.3V devices to communicate with 5V devices. In addition, if the communication on the I²C bus enters the fault state, the AW9548 can be resumed to normal operation through the RESETN pin or by a power-on reset which results from cycling power to the device.

RESETN Input

The RESETN input is an active-low signal that may be used to recover from a bus-fault condition. When this signal is asserted low for a minimum of $t_{W(rst)L}$, the AW9548 resets its registers and I²C state machine and deselected all channels. The RESETN input must be connected to V_{CC} through a pull-up resistor.

Power On Reset

When power is applied to V_{CC}, an internal power-on reset circuit holds the AW9548 in a reset condition until V_{CC} has reached V_{PORR}. At that time, the reset condition is released, and the AW9548 registers and I²C/SMBus state machine are initialized to their default states, all zeroes, causing all the channels to be deselected. After that, V_{CC} must be lowered to below V_{PORF} to reset the device .

Device Address

The AW9548 features 3 hardware address pins (A0, A1 and A2) to allow the user to program the device's I²C address by pulling each pin to either V_{CC} or GND to signify the bit value in the address. This allows up to eight AW9548 devices to be on the same bus without address conflicts. The voltage on the pins must not change while the device is powered up in order to prevent possible I²C glitches as a result of the device address changing during a transmission. All of the pins must be tied either to V_{CC} or GND and cannot be left floating.

The permitted I²C addresses are 0x70 (7-bit) through 0x77 (7-bit). The last bit of the slave address defines the operation (read or write) to be performed. A high (1) selects a read operation, while a low (0) selects a write operation.

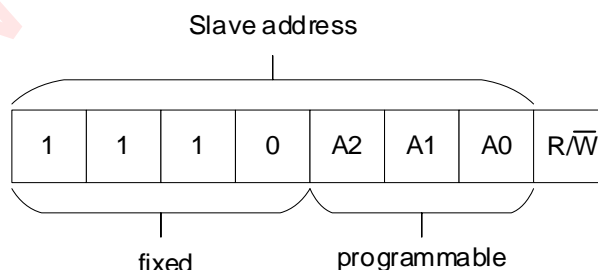

Figure 9 AW9548 Device Address

Control Register

Following the successful acknowledgment of the address byte, the bus master sends a command byte that is stored in the control register in the AW9548 (see figure 10). This register can be written and read via the I²C

bus. Each bit in the command byte corresponds to a SCn/SDn channel and a high (or 1) selects this channel. Multiple SCn/SDn channels may be selected at the same time. When a channel is selected, the channel becomes active after a stop condition has been placed on the I²C bus. This ensures that all SCn/SDn lines are in a high state when the channel is made active, so that no false conditions are generated at the time of connection. A stop condition always must occur immediately after the acknowledge cycle. If multiple bytes are received by the AW9548, it saves the last byte received.

Channel Selection Bits (Read/Write)

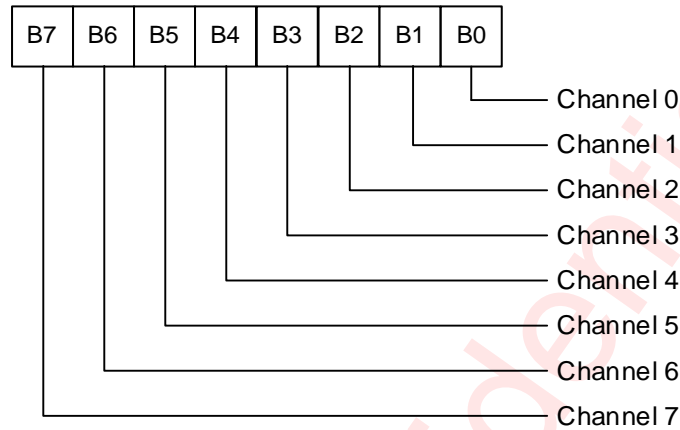

Figure 10 Control Register

Table 1 shows the AW9548 command byte definition.

Table 1 Command Byte Definition

Control register bits								Command
B7	B6	B5	B4	B3	B2	B1	B0	
x	x	x	x	x	x	x	0	Channel 0 disabled
x	x	x	x	x	x	x	1	Channel 0 enabled
x	x	x	x	x	x	0	x	Channel 1 disabled
x	x	x	x	x	x	1	x	Channel 1 enabled
x	x	x	x	x	0	x	x	Channel 2 disabled
x	x	x	x	x	1	x	x	Channel 2 enabled
x	x	x	x	0	x	x	x	Channel 3 disabled
x	x	x	x	1	x	x	x	Channel 3 enabled
x	x	x	0	x	x	x	x	Channel 4 disabled
x	x	x	1	x	x	x	x	Channel 4 enabled
x	x	0	x	x	x	x	x	Channel 5 disabled
x	x	1	x	x	x	x	x	Channel 5 enabled
x	0	x	x	x	x	x	x	Channel 6 disabled
x	1	x	x	x	x	x	x	Channel 6 enabled
0	x	x	x	x	x	x	x	Channel 7 disabled
1	x	x	x	x	x	x	x	Channel 7 enabled
0	0	0	0	0	0	0	0	No channel selected, power-up/reset default state

NOTE: Multiple channels can be enabled at the same time. Example: B7=0, B6=1, B5=0, B4=0, B3=1, B2=1, B1=0, B0=0, means that channels 7, 5, 4, 1 and 0 are disabled and channels 6, 3, and 2 are enabled. Care should be taken not to exceed the maximum bus capacitance. Default condition is all zeroes.

I²C Interface

The AW9548 has a standard bidirectional I²C interface that is controlled by a master device in order to be configured or read the status of this device. Each slave on the I²C bus has a specific device address to differentiate between other slave devices that are on the same I²C bus. Many slave devices require configuration upon startup to set the behavior of the device. This is typically done when the master accesses internal register maps of the slave, which have unique register addresses. A device can have one or multiple registers where data is stored, written, or read.

The I²C-bus is for 2-way, 2-line communication between different ICs or modules. The two lines are a serial data line (SDA) and a serial clock line (SCL). Both lines must be connected to a positive supply via a pull-up resistor when connected to the output stages of a device. The size of the pull-up resistor is determined by the amount of capacitance on the I²C lines. Data transfer may be initiated only when the bus is not busy and a bus is considered idle if both SDA and SCL lines are high after a STOP condition.

Data Validation

When SCL is high level, SDA level must be stable. SDA can be changed only when SCL is low level.

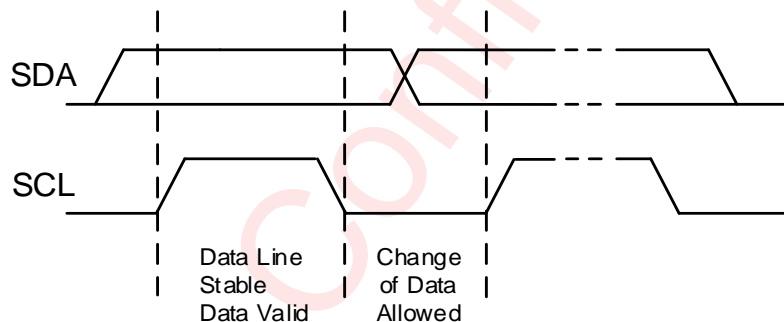

Figure 11 Data Validation Diagram

I²C Start/Stop

I²C start: SDA changes from high level to low level when SCL is high level.

I²C stop: SDA changes from low level to high level when SCL is high level.

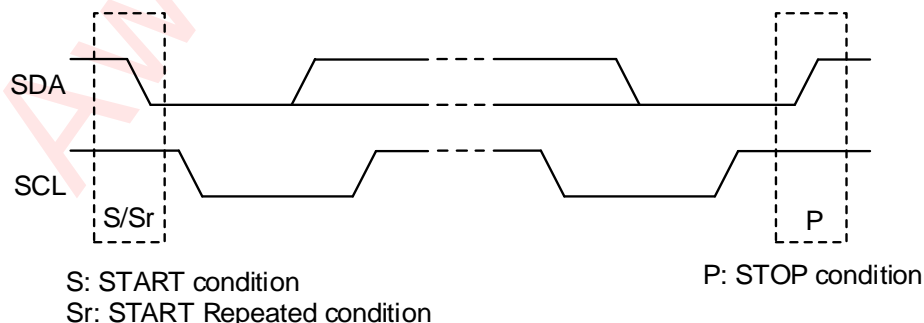

Figure 12 I²C Start/Stop Condition Timing

Acknowledge(ACK)

ACK means the successful transfer of I²C bus data. After master sends an 8-bit data, SDA must be released;

SDA is pulled to GND by slave device when slave acknowledges.

When master reads, slave device sends 8-bit data, releases the SDA and waits for ACK from master. If ACK is sent and I²C stop is not sent by master, slave device sends the next data. If ACK is not sent by master, slave device stops to send data and waits for I²C stop.

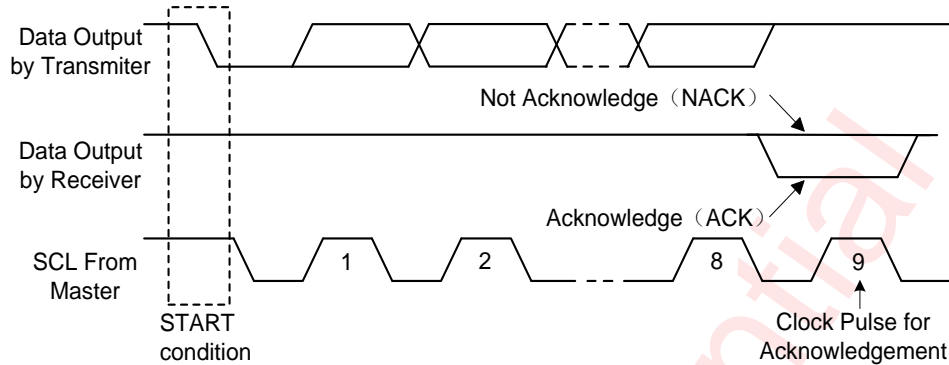

Figure 13 I²C ACK Timing

Bus Transactions

Data must be sent to and received from the slave devices, and this is accomplished by reading from or writing to registers in the slave device.

Registers are locations in the memory of the slave which contain information, whether it be the configuration information or some sampled data to send back to the master. The master must write information to these registers in order to instruct the slave device to perform a task.

While it is common to have registers in I²C slaves, note that not all slave devices have registers. Some devices are simple and contain only one register, which may be written to directly by sending the register data immediately after the slave address, instead of addressing a register. The AW9548 is example of a single-register device, which is controlled via I²C commands. Since it has 1 bit to enable or disable a channel, there is only one register needed, and the master merely writes the register data after the slave address, skipping the register number.

Writes

To write on the I²C bus, the master sends a START condition on the bus with the address of the slave, as well as the last bit (the R/W bit) set to 0, which signifies a write. The slave acknowledges, letting the master know it is ready. After this, the master starts sending the control register data to the slave until the master has sent all the data necessary (which is sometimes only a single byte), and the master terminates the transmission with a STOP condition.

There is no limit to the number of bytes sent, but the last byte sent is what is in the register.

Figure 14 shows an example of writing a single byte to a slave register.

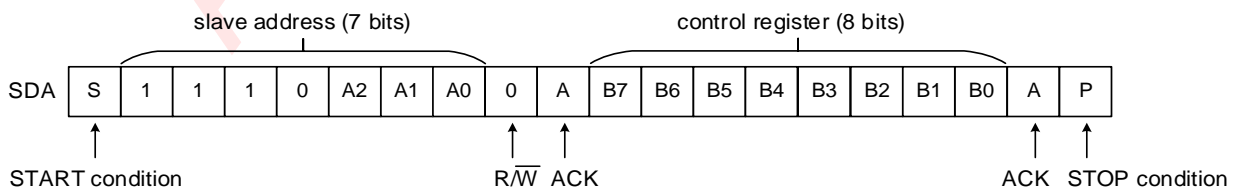

Figure 14 Write To Control Register

Reads

Reading from a slave is very similar to writing, but the master sends a START condition, followed by the slave

address with the R/W bit set to 1 (signifying a read). The slave acknowledges the read request, and the master releases the SDA bus but continues supplying the clock to the slave. During this part of the transaction, the master becomes the master-receiver, and the slave becomes the slave-transmitter.

The master continues to send out the clock pulses, but releases the SDA line so that the slave can transmit data. At the end of every byte of data, the master sends an ACK to the slave, letting the slave know that it is ready for more data. Once the master has received the number of bytes it is expecting, it sends a NACK, signaling to the slave to halt communications and release the bus. The master follows this up with a STOP condition.

Figure 15 shows an example of reading a single byte from a slave register.

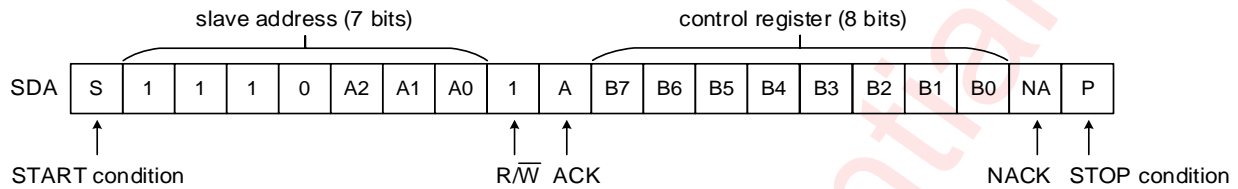

Figure 15 Read From Control Register

Application Information

Applications of the AW9548 contain an I²C (or SMBus) master device and up to eight I²C slave devices. The downstream channels are ideally used to resolve I²C slave address conflicts. For example, if eight identical digital temperature sensors are needed in the application, one sensor can be connected at each channel: 0-7. When the temperature at a specific location needs to be read, the appropriate channel can be enabled and all other channels switched off, the data can be retrieved, and the I²C master can move on and read the next channel.

In an application where the I²C bus contains many additional slave devices that do not result in I²C slave address conflicts, these slave devices can be connected to any desired channel to distribute the total bus capacitance across multiple channels. If multiple switches are enabled simultaneously, additional design requirements must be considered (see the Design Requirements section and Pull-up Resistor Calculation section). Figure 16 shows an application in which the AW9548 can be used.

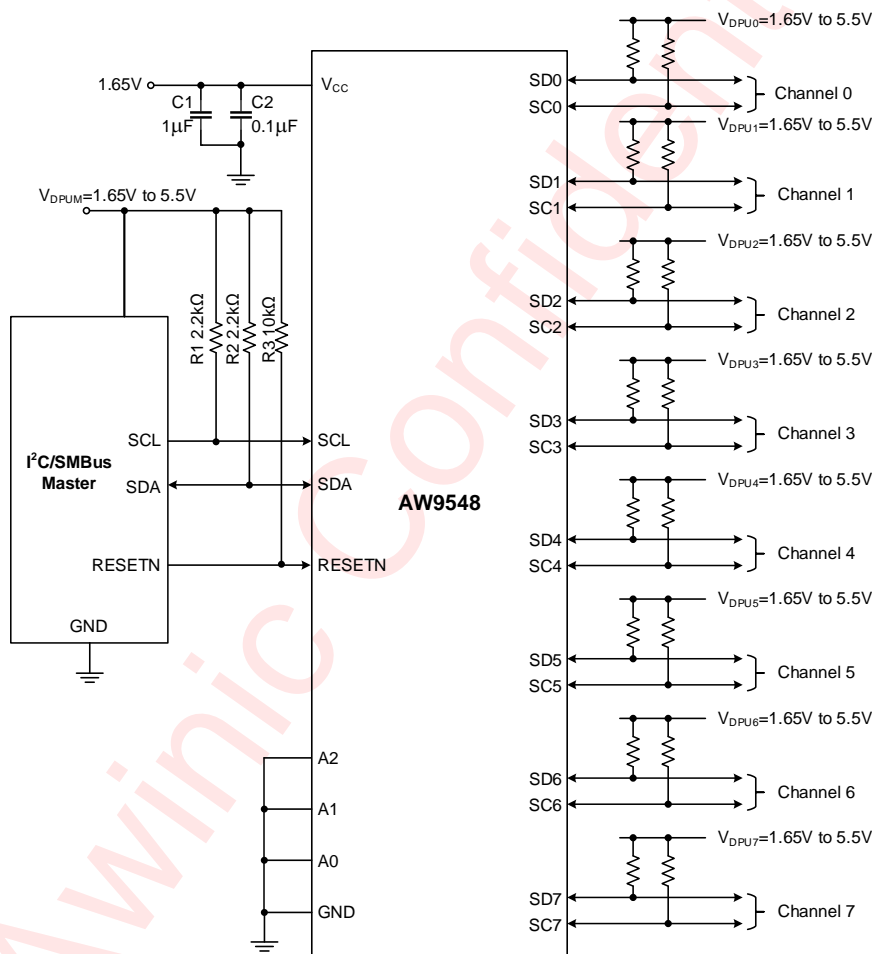

Figure 16 AW9548 Application Circuit

Design Requirements

A typical application of the AW9548 contains one or more data pull-up voltages, V_{DPUX} , one for the master device (V_{DPU0}) and one for each of the selectable slave channels ($V_{DPU1} \sim V_{DPU7}$). In the event where the master device and all slave devices operate at the same voltage, then $V_{DPU0} = V_{DPU1} = \dots = V_{DPU7} = V_{CC}$. In an application where voltage translation is necessary, additional design requirements must be considered to determine an appropriate V_{CC} voltage.

The A0, A1 and A2 pins are hardware selectable to control the slave address of the AW9548. These pins may be tied directly to GND or V_{CC} in the application.

If multiple slave channels are activated simultaneously in the application, then the total I_{OL} from SCL/SDA to GND on the master side is the sum of the currents through all pull-up resistors, R_p .

The pass-gate transistors of the AW9548 are constructed such that the V_{CC} voltage can be used to limit the maximum voltage that is passed from one I²C bus to another.

Figure 17 shows the voltage characteristics of the pass-gate transistors (note that the graph was generated using data specified in the Electrical Characteristics table). In order for the AW9548 to act as a voltage translator, the $V_{O(SW)}$ voltage must be equal to or lower than the lowest bus voltage. For example, if the main bus is running at 5V and the downstream buses are 3.3V and 2.7V, $V_{O(SW)}$ must be equal to or below 2.7V to effectively clamp the downstream bus voltages. As shown in figure 17, $V_{O(SW)(max)}$ is 2.7V when the AW9548 supply voltage is 4V or lower, so the AW9548 supply voltage could be set to 3.3V. Pull-up resistors then can be used to bring the bus voltages to their appropriate levels (see figure 16).

Pull-up Resistor Calculation

Once all the slaves are assigned to the appropriate slave channels and bus voltages are identified. The pull-up resistors, R_p , for each of the buses need to be selected appropriately. The minimum pull-up resistance is a function of V_{DPUX} , $V_{OL(max)}$, and I_{OL} as shown in Equation 1.

$$R_{p(min)} = \frac{V_{DPUX} - V_{OL(max)}}{I_{OL}} \quad (1)$$

The maximum pull-up resistance is a function of the maximum rise time, t_r (300ns for fast-mode operation, $f_{SCL} = 400kHz$) and bus capacitance, C_b as shown in Equation 2.

$$R_{p(max)} = \frac{t_r}{0.8473 \times C_b} \quad (2)$$

The maximum bus capacitance for an I²C bus must not exceed 400pF for standard-mode or fast-mode operation. The bus capacitance can be approximated by adding the capacitance of the AW9548, $C_{io(off)}$, the capacitance of wires, connections and traces, and the capacitance of additional slaves on the bus. If multiple channels are activated simultaneously, each of the slaves on all channels contribute to total bus capacitance.

Application Curves

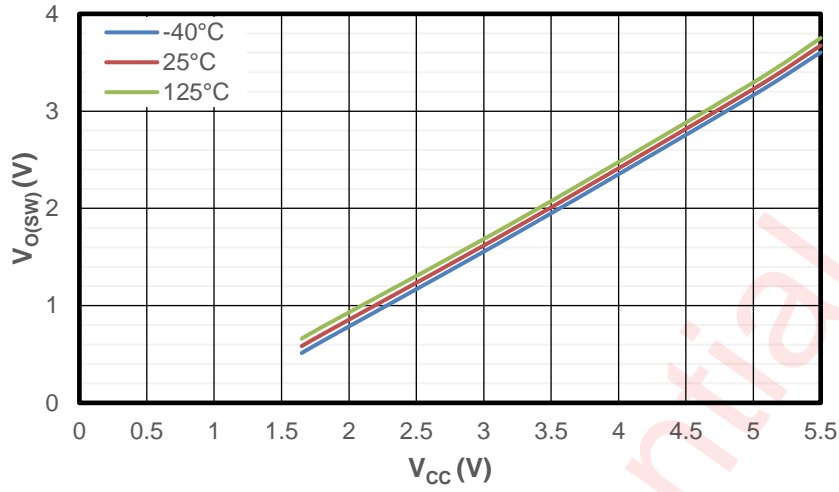
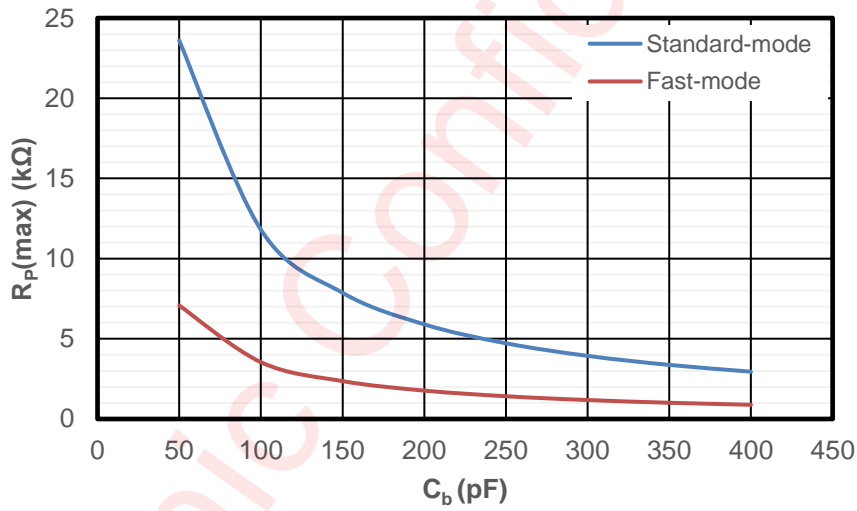

Figure 17 Pass-Gate Voltage ($V_{O(SW)}$) vs Supply Voltage (V_{CC})



Standard-mode

Fast-mode

(f_{SCL}=100kHz, t_r=1μs)

(f_{SCL}=400kHz, t_r=300ns)

Figure 18 Maximum Pull-Up Resistance ($R_{P(max)}$) vs Bus Capacitance (C_b)

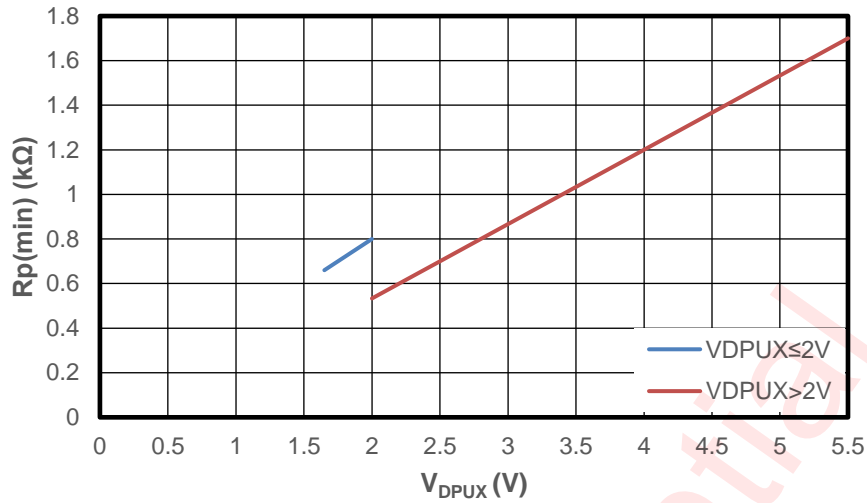

$V_{OL}=0.2 \cdot V_{DPUX}$, $I_{OL}=2mA$ when $V_{DPUX} \leq 2V$

$V_{OL}=0.4V$, $I_{OL}=3mA$ when $V_{DPUX} > 2V$

Figure 19 Minimum Pull-up Resistance ($R_p(\min)$) vs Pull-up Reference Voltage (V_{DPUX})

Power Supply Recommendations

The operating power-supply voltage range of the AW9548 is 1.65V to 5.5V applied at the V_{CC} pin. When the AW9548 is powered on for the first time or anytime the device must be reset by cycling the power supply, the power-on reset requirements must be followed to ensure the I²C bus logic is initialized properly.

Power-On Reset Requirements

In the event of a glitch (data output or input or even power) or data corruption, the AW9548 can be reset to its default conditions by using the power-on reset feature. Power-on reset requires that the device go through a power cycle to be completely reset. This reset also happens when the device is powered on for the first time in an application.

A power-on reset is shown in figure 20.

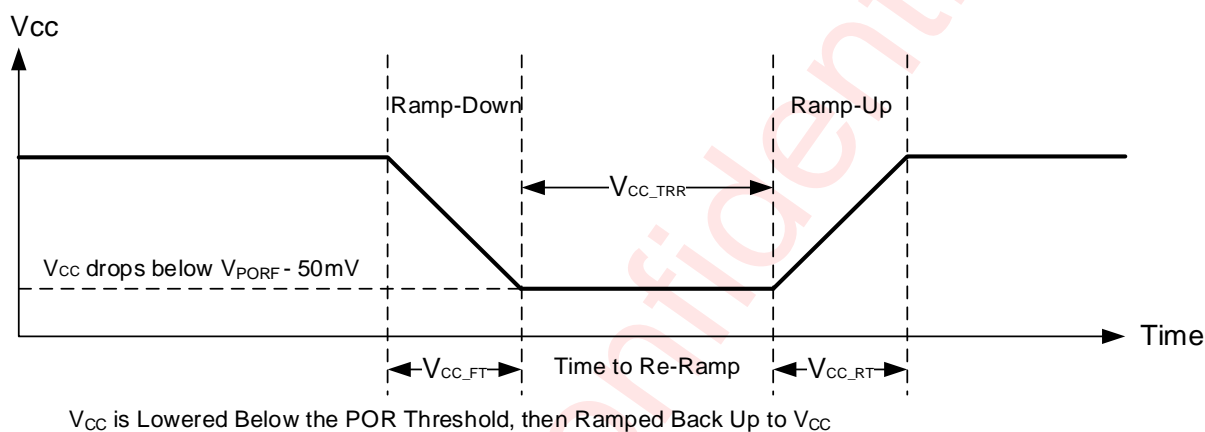

Figure 20 Power-On Reset Waveform

Table 2 specifies the performance of the power-on reset feature for AW9548 for both types of power-on reset.

Table 2 Recommended Supply Sequencing and Ramp Rates

Parameters			Min.	Max.	Unit
V_{CC_FT}	Fall rate	See Figure 20	1	100	ms
V_{CC_RT}	Rise rate	See Figure 20	0.1	100	ms
V_{CC_TRR}	Time to re-ramp (V_{CC} drops to $V_{PORF}(\min) - 50$ mV or when V_{CC} drops to GND)	See Figure 20	40		μ s
V_{CC_GH}	Level that V_{CC} can glitch down to, but not cause a functional disruption when $V_{CC_GW}=1\mu$ s	See Figure 21		1.2	V
V_{CC_GW}	Glitch width that does not cause a functional disruption when $V_{CC_GH}=0.5\times V_{CC}$	See Figure 21		10	μ s

Glitches in the power supply can also affect the power-on reset performance of this device. The glitch width (V_{CC_GW}) and height (V_{CC_GH}) are dependent on each other. The bypass capacitance, source impedance, and device impedance are factors that affect power-on reset performance. figure 21 and table 2 provide more information on how to measure these specifications.

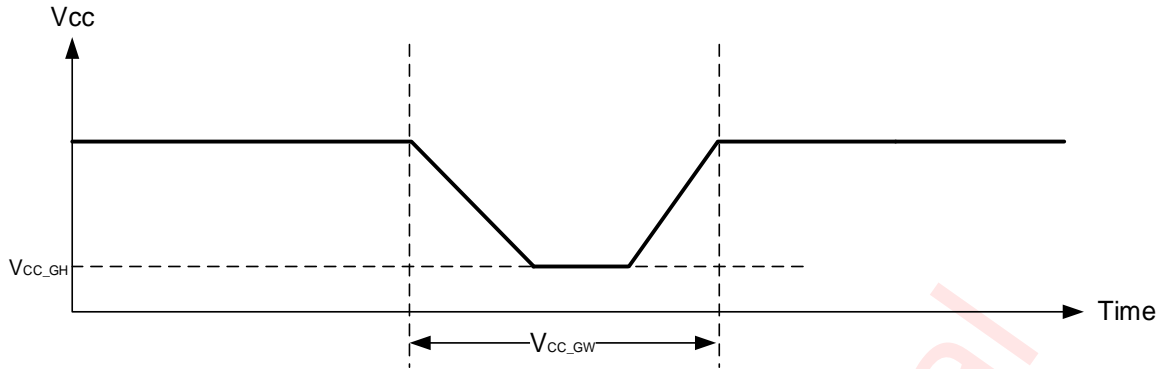

Figure 21 Glitch Width and Glitch Height

V_{POR} is critical to the power-on reset. V_{POR} is the voltage level at which the reset condition is released and all the registers and the I²C/SMBus state machine are initialized to their default states. The value of V_{POR} differs based on the V_{CC} being lowered to or from 0. Figure 22 and table 2 provide more details on this specification.

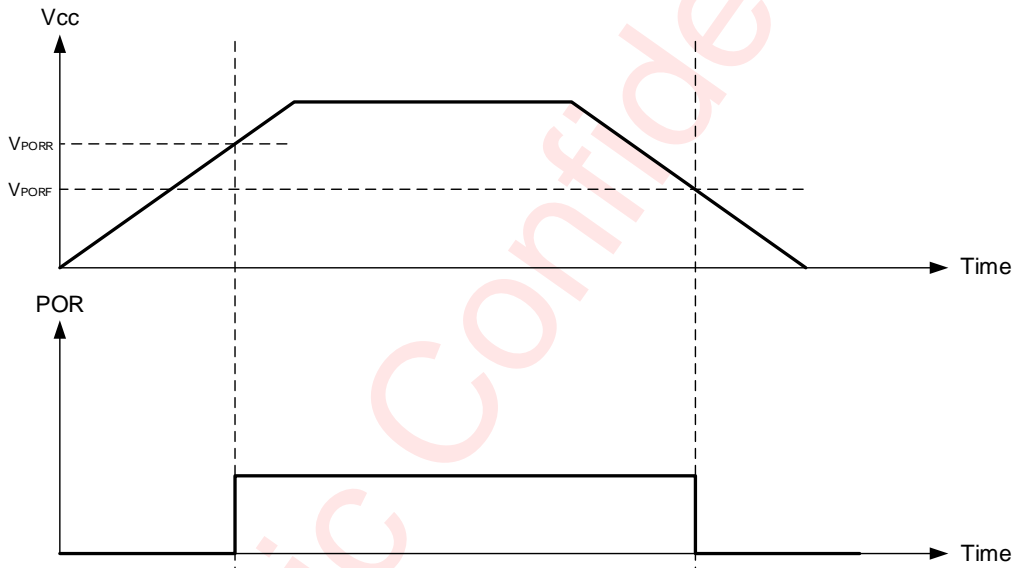

Figure 22 V_{POR}

PCB Layout Consideration

To obtain the good thermal performance, PCB layout should be considered carefully. Here are some guidelines:

1. The C1, C2 should be placed as close to the chip as possible.
2. To reduce the total I²C bus capacitance added by PCB parasitics, data lines (SCn and SDn) must be as short as possible and the widths of the traces must also be minimized.
3. In an application where voltage translation is not required, all V_{DPUX} voltages and V_{CC} could be at the same potential and a single copper plane could connect all of pull-up resistors to the appropriate reference voltage. In an application where voltage translation is required, V_{DPU0} and V_{DPU0}~V_{DPU7}, may all be on the same layer of the board with split planes to isolate different voltage potentials.

Awinic Confidential

Tape And Reel Information

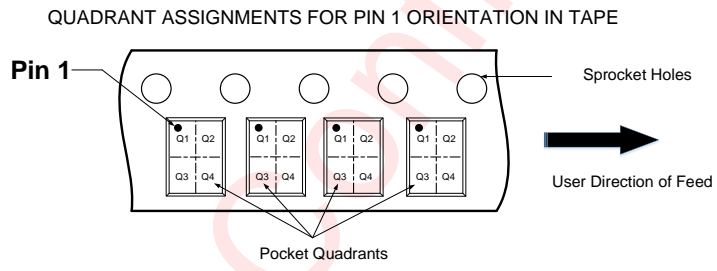
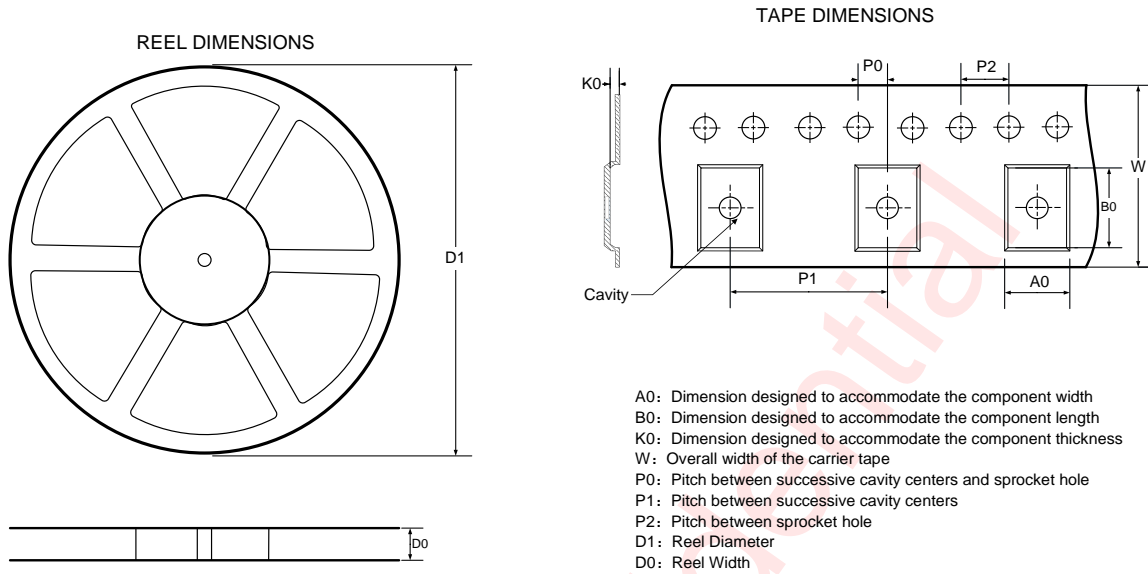

Note: The above picture is for reference only. Please refer the value in the table below for actual size.

DIMENSIONS AND PIN1 ORIENTATION

D1 (mm)	D0 (mm)	A0 (mm)	B0 (mm)	K0 (mm)	P0 (mm)	P1 (mm)	P2 (mm)	W (mm)	Pin1 Quadrant
330.0	16.4	6.8	8.3	1.6	2.0	8.0	4.0	16.0	Q1

All dimensions are nominal

AW9548TSR Tape And Reel Information

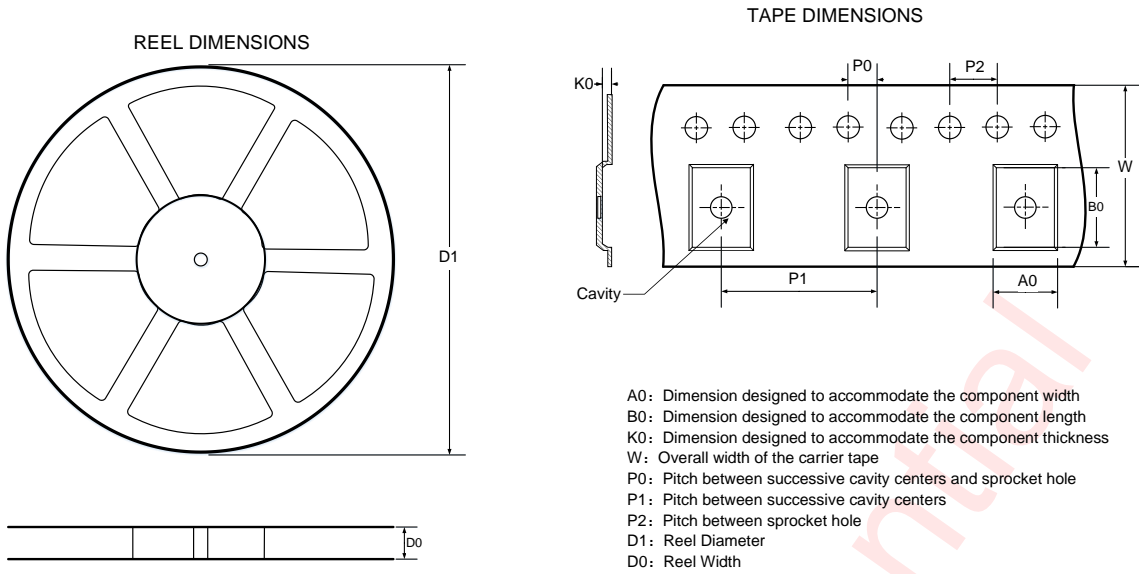

QUADRANT ASSIGNMENTS FOR PIN 1 ORIENTATION IN TAPE

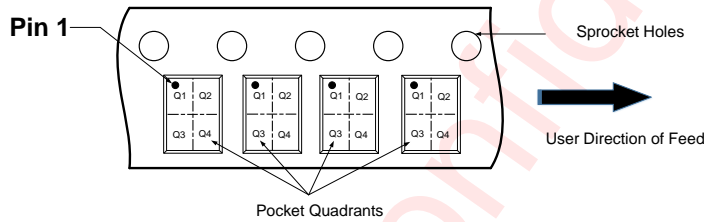

Note: The above picture is for reference only. Please refer the value in the table below for actual size.

DIMENSIONS AND PIN1 ORIENTATION

D1 (mm)	D0 (mm)	A0 (mm)	B0 (mm)	K0 (mm)	P0 (mm)	P1 (mm)	P2 (mm)	W (mm)	Pin1 Quadrant
330.0	12.4	4.3	4.3	1.1	2.0	8.0	4.0	12.0	Q1

All dimensions are nominal

AW9548QNR Tape And Reel Information

Package Description

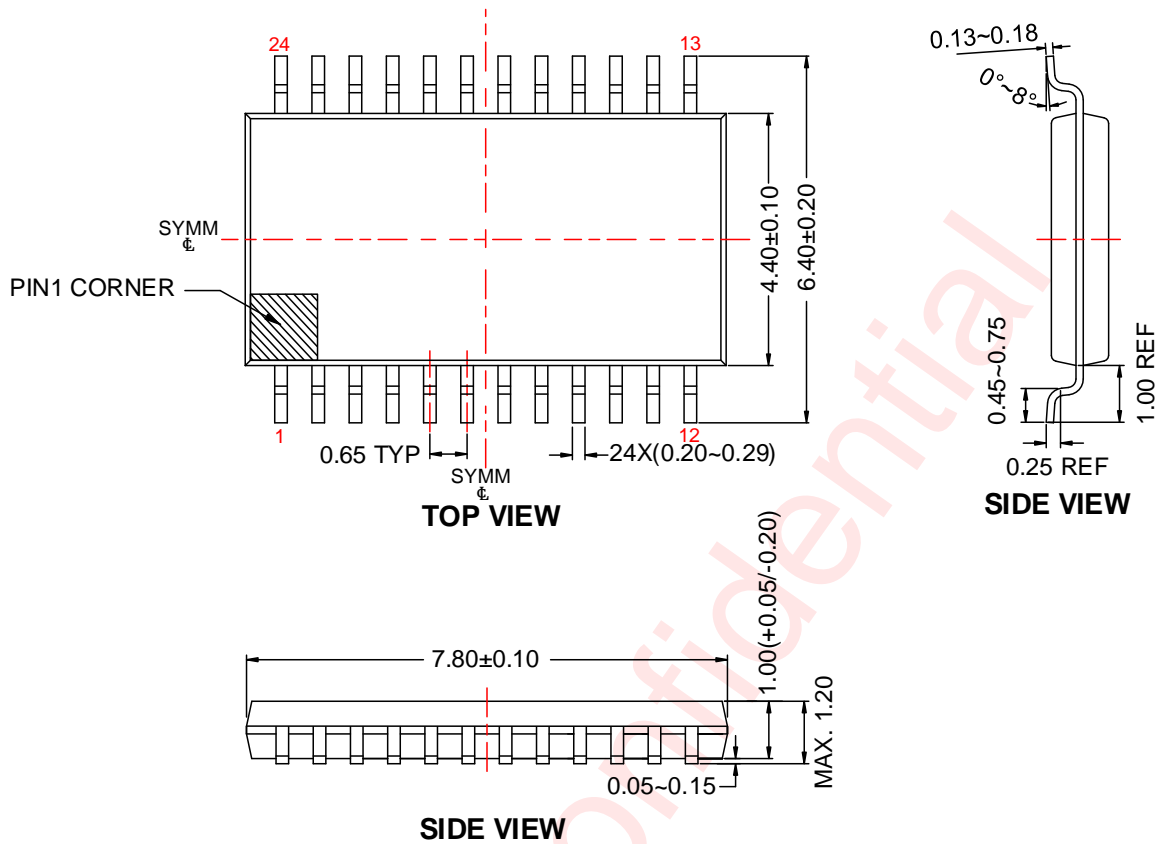

Unit:mm

AW9548TSR Package Description

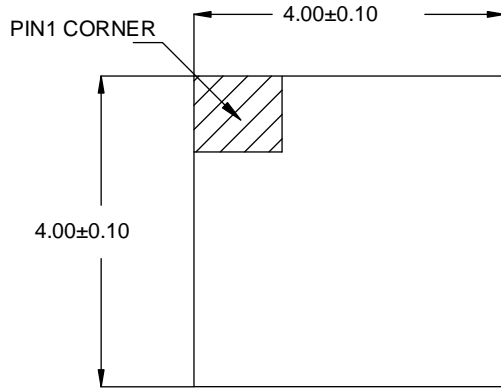

Top View



Side View

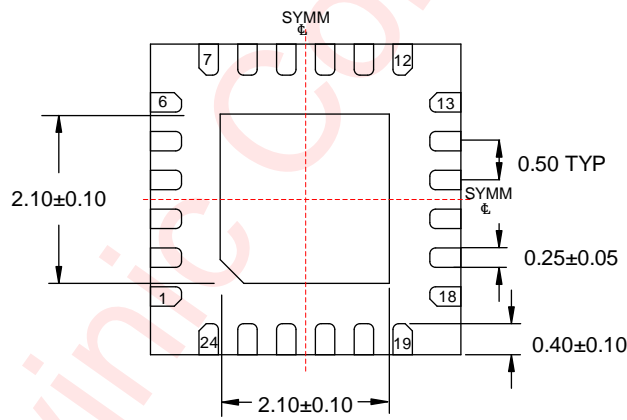

Bottom View

Unit:mm

AW9548QNR Package Description

Land Pattern Data

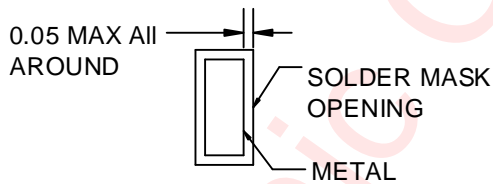
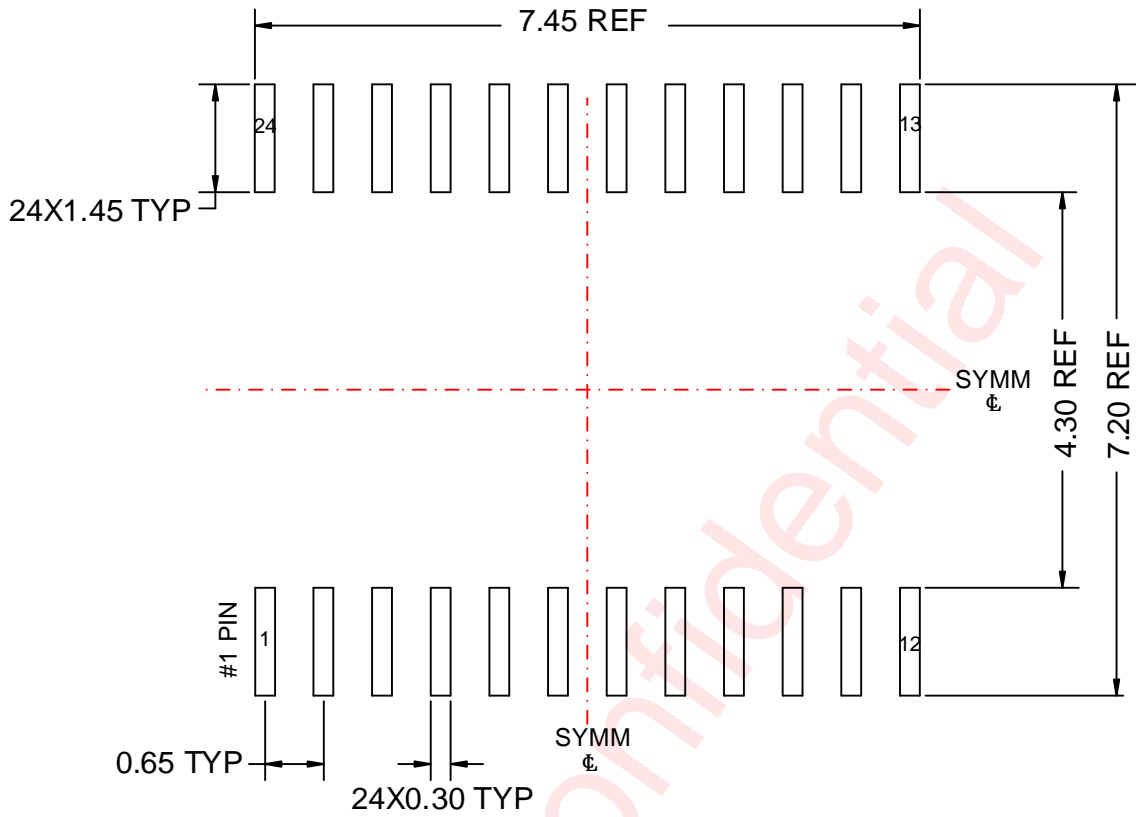

NON SOLDER MASK DEFINED

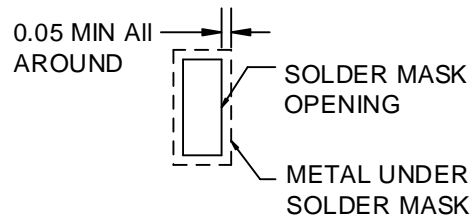

SOLDER MASK DEFINED

Unit: mm

AW9548TSR Land Pattern Data

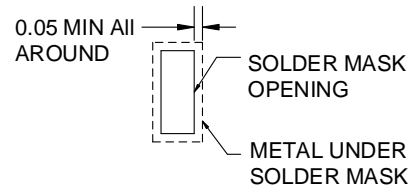
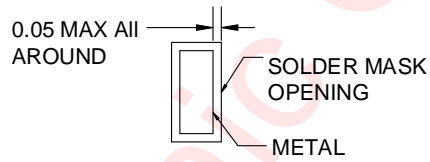
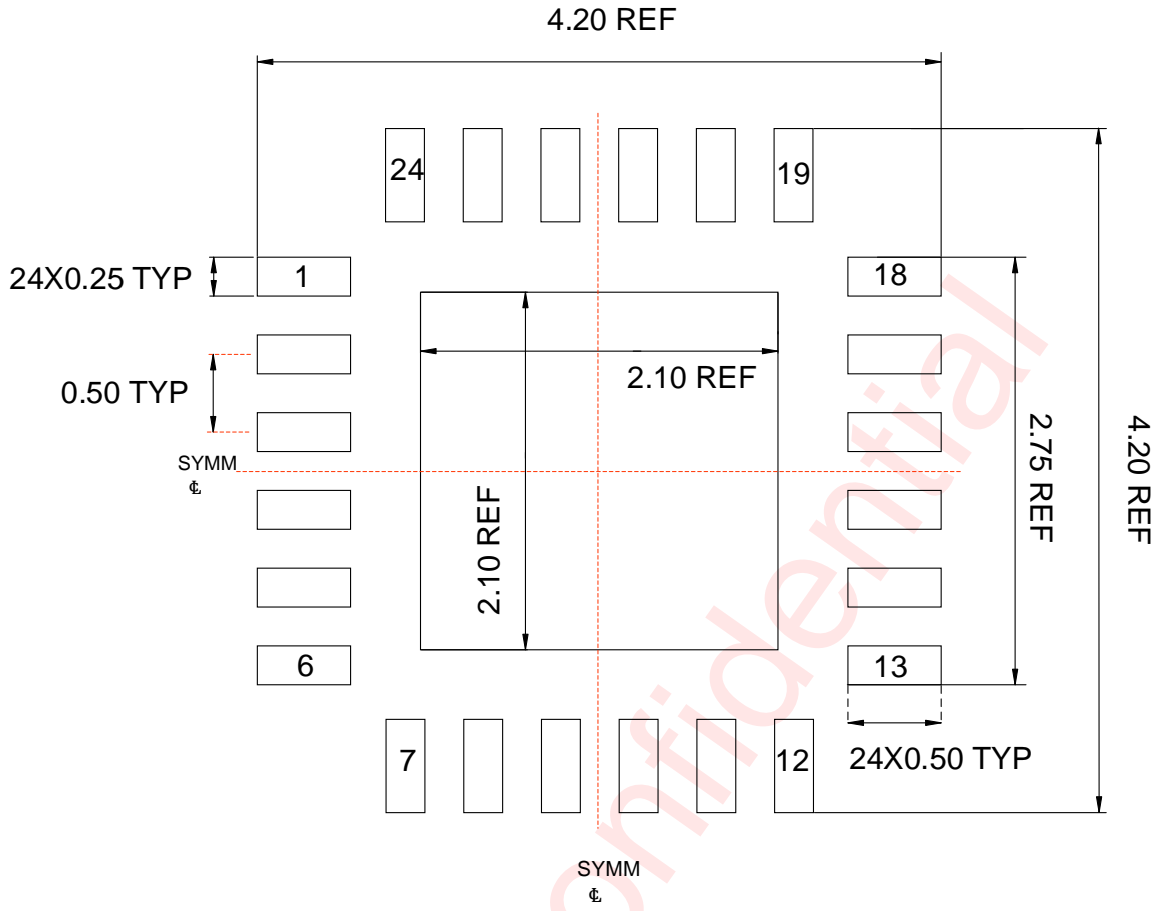

NON SOLDER MASK DEFINED

SOLDER MASK DEFINED

Unit: mm

AW9548QNR Land Pattern Data

Revision History

Version	Date	Change Record
V1.0	Aug. 2023	Officially released
V1.1	Jan. 2024	Update the moisture sensitivity level (P5).
V1.2	Oct. 2024	Add AW9548QNR

Awinic Confidential

Disclaimer

All trademarks are the property of their respective owners. Information in this document is believed to be accurate and reliable. However, Shanghai AWINIC Technology Co., Ltd (AWINIC Technology) does not give any representations or warranties, expressed or implied, as to the accuracy or completeness of such information and shall have no liability for the consequences of use of such information.

AWINIC Technology reserves the right to make changes to information published in this document, including without limitation specifications and product descriptions, at any time and without notice. Customers shall obtain the latest relevant information before placing orders and shall verify that such information is current and complete. This document supersedes and replaces all information supplied prior to the publication hereof.

AWINIC Technology products are not designed, authorized or warranted to be suitable for use in medical, military, aircraft, space or life support equipment, nor in applications where failure or malfunction of an AWINIC Technology product can reasonably be expected to result in personal injury, death or severe property or environmental damage. AWINIC Technology accepts no liability for inclusion and/or use of AWINIC Technology products in such equipment or applications and therefore such inclusion and/or use is at the customer's own risk.

Applications that are described herein for any of these products are for illustrative purposes only. AWINIC Technology makes no representation or warranty that such applications will be suitable for the specified use without further testing or modification.

All products are sold subject to the general terms and conditions of commercial sale supplied at the time of order acknowledgement.

Nothing in this document may be interpreted or construed as an offer to sell products that is open for acceptance or the grant, conveyance or implication of any license under any copyrights, patents or other industrial or intellectual property rights.

Reproduction of AWINIC information in AWINIC data books or data sheets is permissible only if reproduction is without alteration and is accompanied by all associated warranties, conditions, limitations, and notices. AWINIC is not responsible or liable for such altered documentation. Information of third parties may be subject to additional restrictions.

Resale of AWINIC components or services with statements different from or beyond the parameters stated by AWINIC for that component or service voids all express and any implied warranties for the associated AWINIC component or service and is an unfair and deceptive business practice. AWINIC is not responsible or liable for any such statements.