



HAICHUANG SEMI

2306

30V N-Channel Enhancement

General Description



V(BR)DSS	RDSON MAX	ID Max.
30V	47mΩ @10V	3.16A
	65mΩ @4.5V	

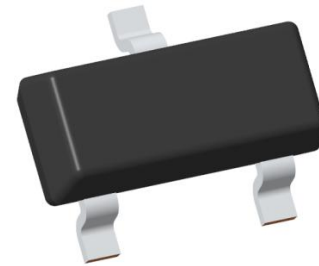

Features

- Lead free product is acquired
- Surface mount package
- Moisture Sensitivity Level 3

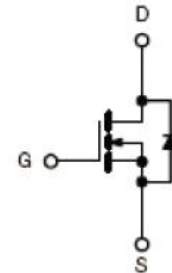

Mechanical Data

- SOT-23 Small Outline Plastic Package.
- Epoxy UL: 94V-0.
- Mounting Position: Any.



Package Marking and Ordering Information

Product ID	Pack	Marking	Qty(PCS)
2306	SOT-23	S6	3000

Absolute Maximum Ratings (Ta=25°C unless otherwise noted)

Parameter	Symbols	Value	Units
Drain-Source Voltage	VDS	30	V
Gate-Source Voltage	VGS	±20	V
Continuous Drain Current	ID	3.16	A
Pulsed Drain Current	IDM	20	
Continuous Source-Drain Current	IS	0.62	
Power Dissipation	PD	750	mW
Junction Temperature	Tj	150	°C
Storage Temperature	Tstg	-50-+150	°C
Thermal Resistance From Junction to Ambient	RθJA	167	°C/W

Electrical Characteristics (Ta=25°C, unless otherwise noted)

Parameter	Symbol	Test Conditions	Min.	Typ.	Max.	Unit
Off Characteristics						
Drain-Source Breakdown Voltage	V(BR)DSS	VGS=0V, ID=250uA	30			V
Gate-body Leakage	IGSS	VDS=0V, VGS=±20V			±100	nA
Zero Gate Voltage Drain current	IDSS	VDS=30V, VGS=0V			0.5	uA
On Characteristics						
Gate-Threshold voltage	VGS(th)	VDS=VGS, ID=250uA	1		3	V
Drain-Source On-Resistance (Note1)	RDS(ON)	VGS=4.5V, ID=2.8A		52	65	mΩ
		VGS=10V, ID=3.5A		38	47	
Body diode voltage	VSD	IS=1.25A, VGS=0V		0.8	1.2	V
Forward Transconductance (Note1)	gfs	VDS=4.5V, ID=2.5A		70		S
Dynamic (Note2)						
Input capacitance	Ciss	VDS=15V, VGS=0V, f=1MHz		305		pF
Output capacitance	Coss			65		
Reverse Transfer capacitance	Crss			2		
Gate Charge	Qg	VGS=5V, VDS=15V, ID=2.5A		3.0	4.5	nC
Total gate charge	Qgt	VGS=10V, VDS=15V, ID=2.5A		6	9	
Gate-source charge	Qgs			1.6		
Gate-drain charge	Qgd			0.6		
Gate Resistance	Rg	f=1MHz	2.5	5	7.5	Ω
Switching (Note2)						
Turn-on Time	td(on)	VDD=15V, RL=15Ω , ID=1A, VGEN=10V, Rg=6Ω		7	11	ns
Rise time	tr			12	18	
Turn-off Time	td(off)			14	25	
Fall time	tf			6	10	

Notes :

1. Pulse Test : Pulse Width < 300μs, Duty Cycle ≤2%.
2. These parameters have no way to verify.



Typical Characteristics

Output Characteristics

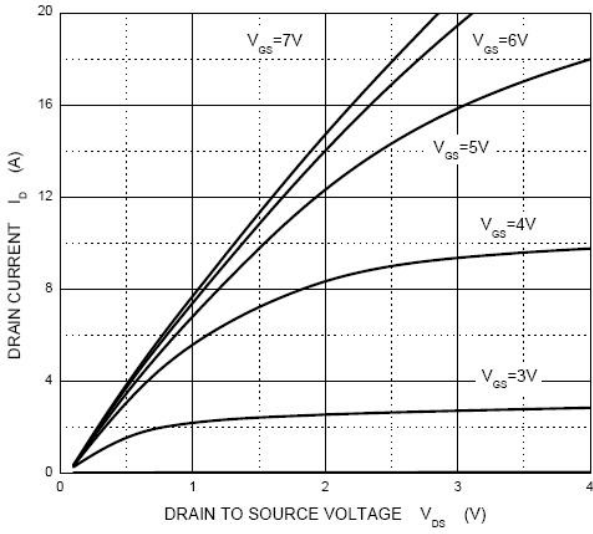

Transfer Characteristics

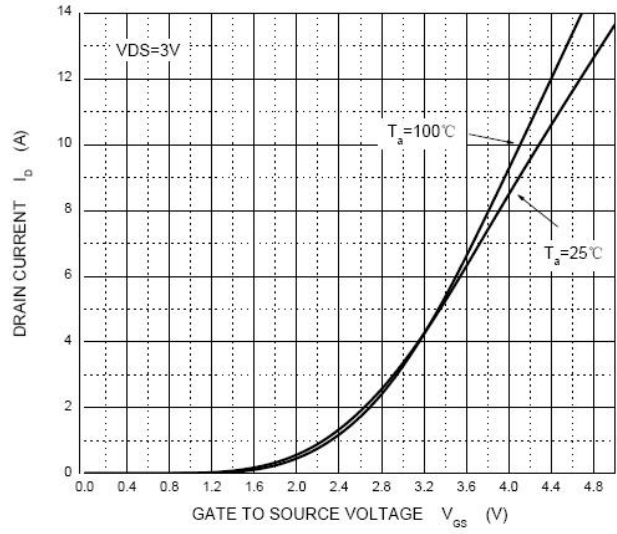

$R_{DS(ON)}$ — I_D

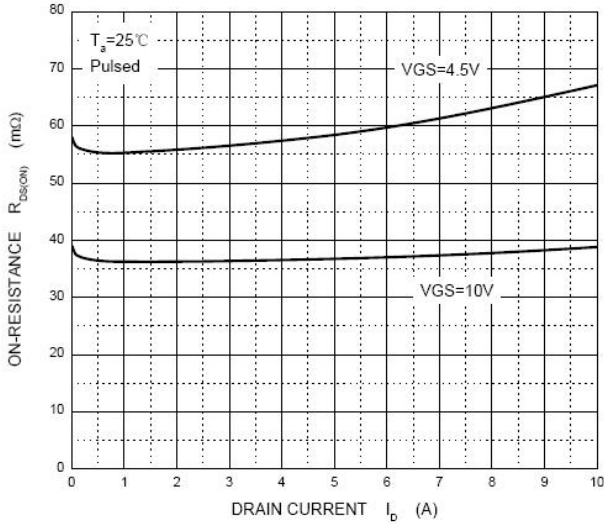

$R_{DS(ON)}$ — V_{GS}

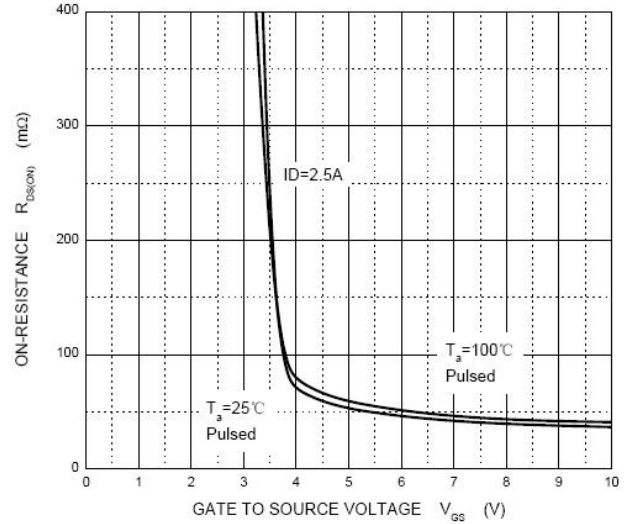

I_S — V_{SD}

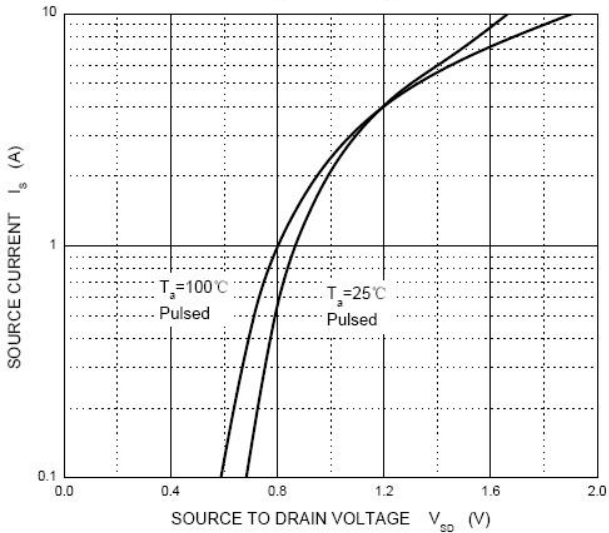

Threshold Voltage

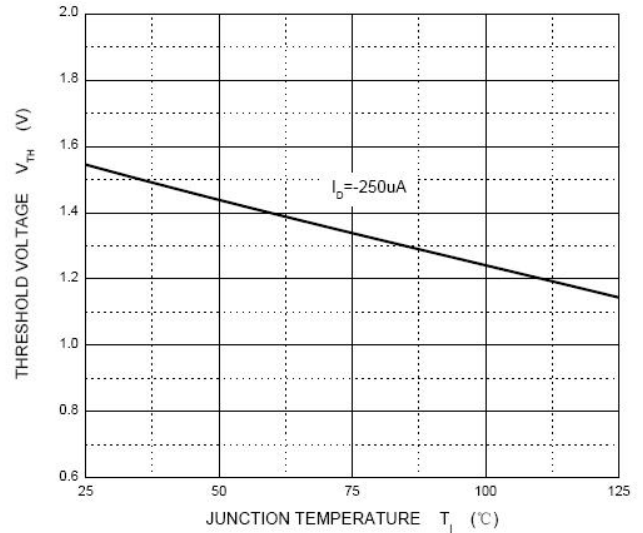

Package Information

Carrier Dimension(mm)

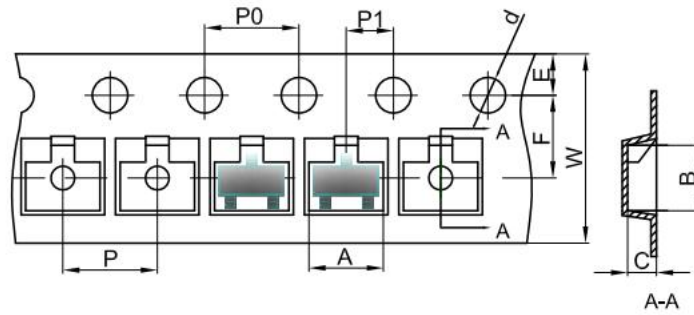

Dimensions are in millimeter

Pkg Type	A	B	C	d	E	F	P0	P	P1	10*P0	W
SOT-23	3.15	2.77	1.22	Ø1.50	1.75	3.50	4.00	4.00	2.00	40.00	8.00
(Tolerance)	±0.1	±0.1	±0.1	±0.1	±0.1	±0.1	±0.1	±0.1	±0.1	±0.2	±0.1

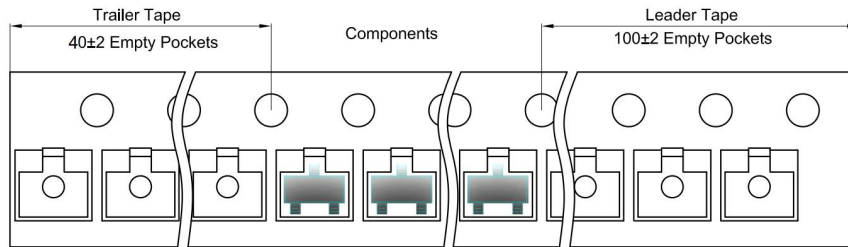

Reel Dimension(mm)

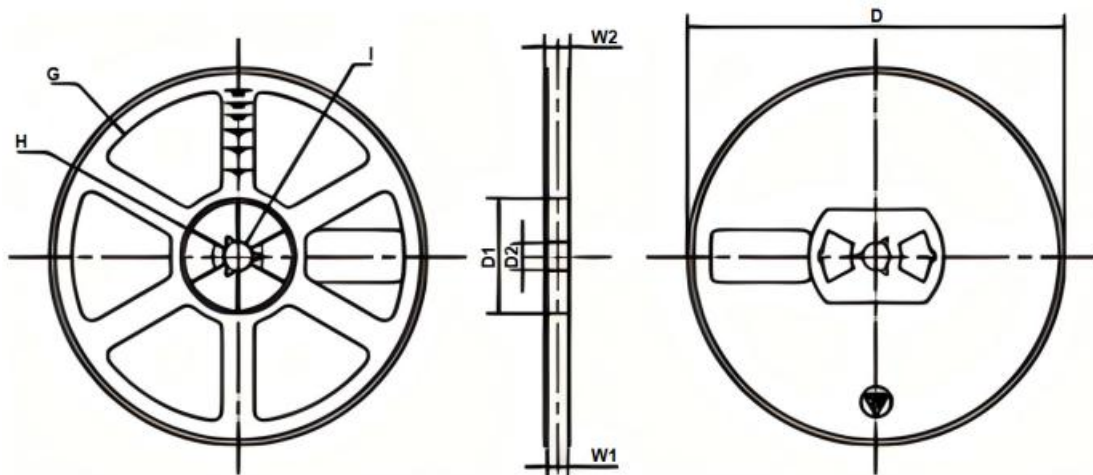

Reel Option	D	D1	D2	G	H	I	W1	W2
7" Dia	Φ178.00	54.40	13.00	R78.00	R25.60	R6.50	9.50	12.30
Tolerance	±2	±1	±1	±1	±1	±1	±1	±1

Package Specifications

Package	Reel Size	Reel DIA. (mm)	Q'TY/Reel (Kpcs)	Box Size (mm)	QTY/Box (Kpcs)	Carton Size (mm)	Q'TY/Carton (Kpcs)
SOT23	7'	178	3	210*208*203	45	440*400*230	180

Recommended Soldering Profile for Rectifier Diodes (Pb Free)

a) Wave Soldering Profile

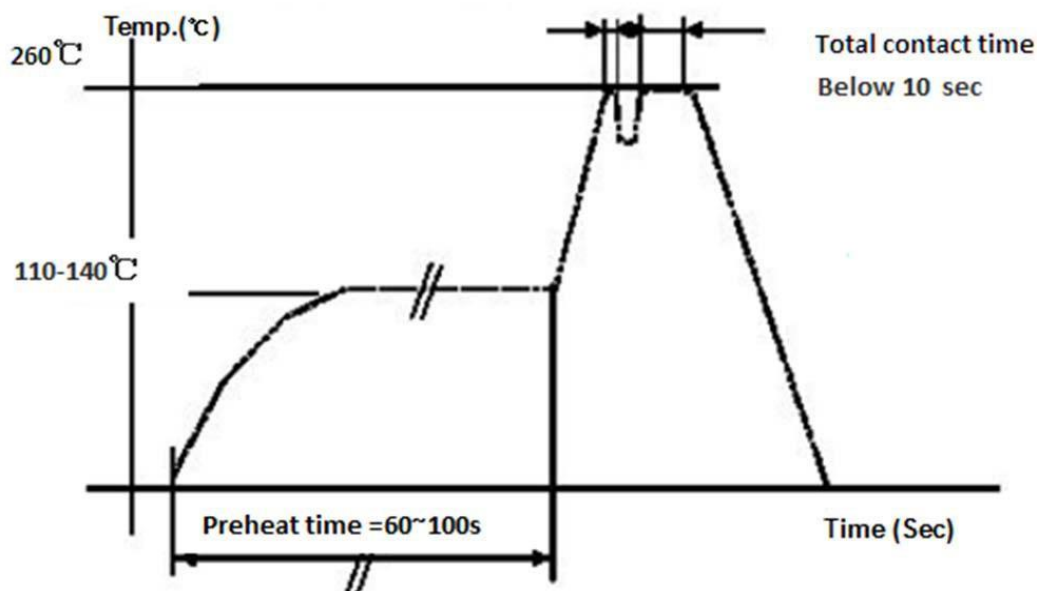

b) Reflow Soldering Profile (Pb Free Application), refer to IPC/JEDEC J-STD-020

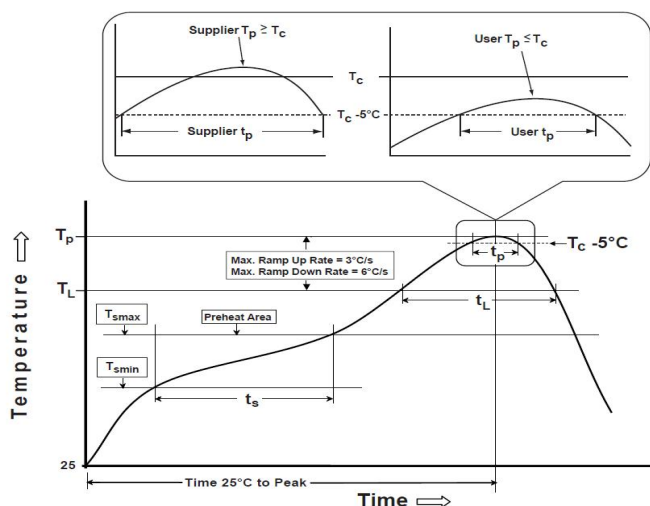

Preheat/Soak Temperature Min (T _{smin}) Temperature Max (T _{smax}) Time (t _s) from (T _{smin} to T _{smax})	50 °C 200 °C 60-120 seconds
Melting Point of Solder (Sn Ag Cu)	217°C
Ramp-up Rate to 217°C(Melting Point of Solder)	3°C/sec
Time at Temp.>217°C (Melting Point of Solder)	60~150 Sec
Peak Temperature	255±5°C
Time within 5°Cbelow Peak Temp.	20~40 Sec
Cooling Rate	6°C/sec (max)
Time from 25°C to Peak Temp.	8min (max)

c) Manual Soldering

When using an electric soldering iron for manual soldering, it is recommended that the temperature does not exceed 300°C and the soldering time is less than 10 seconds.

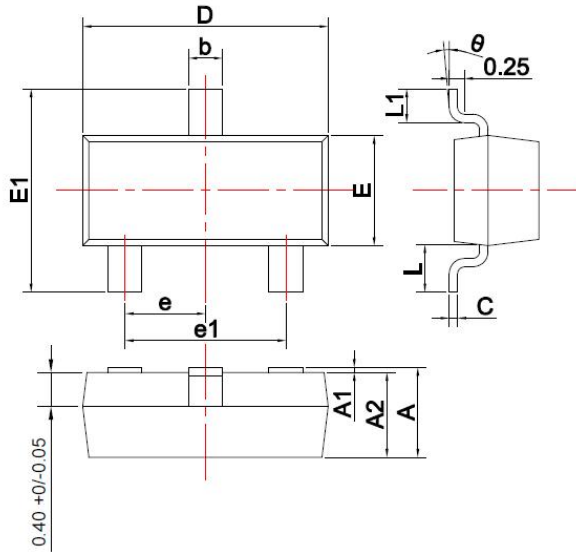

SYMBOL	DIMENSIONS	
	MIN.	MAX.
A	0.900	1.150
A1	0.000	0.100
A2	0.900	1.050
b	0.300	0.500
c	0.080	0.150
D	2.800	3.000
E	1.200	1.400
E1	2.250	2.550
e	0.950TYP	
e1	1.800	2.000
L	0.550REF	
L1	0.300	0.500
θ	0°	8°

Unit: mm

Suggested Pad Layout

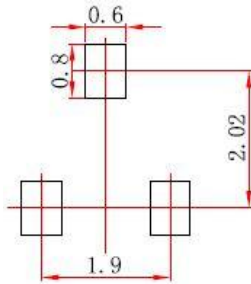

Note:

1. Controlling dimension: In millimeters.
2. General tolerance: ± 0.05 mm.
3. The pad layout is for reference purposes only.