

4-channel Force Touch AFE

Features

- 4 analog input differential channel
- Selectable Gains of 1,8,16, 32, 64, 128, 256,512,1024
- 150 KSPS 14-bit SAR ADC
- 11-bit offset calibration DAC
- Support 400KHz/1MHz I²C
- 1 smart watch dog timer(SWDT)
- Support Temperature Sense
- 1 INTN pin
- Power-on reset, Low voltage detection
- Low voltage reset
- Low power consumption mode
- Built-in pressing algorithm
- WLCSP 1.41mmX1.41mmX0.34mm-16B package

Applications

TWS IOT
Mobile phones
Smart Home

General Description

AW86864 is a chip of force touch AFE, which has the functions of pressure sensing signal acquisition, amplification and processing. It integrated 1 I²C module, 1 system control module, 1 power management module and 1 AFE module (Include 4 analog input differential channel and MUX, level 2 PGA, 11-bit offset calibration DAC, 14bit ADC and pressing algorithm).

AW86864 can enter low power consumption mode automatically without the master participation and trigger AFE work through SWDT wake-up to sample and process the signal. In low power consumption mode, the operating frequency of the chip is 10Hz and the power consumption is 8~13 μ A. Interrupt signals such as sampling completion, threshold comparison and press event trigger can be configured to output through interrupt pin.

The AW86864 is available in a WLCSP 1.41mmX1.41mmX0.34mm-16B package.

Typical Application Circuit

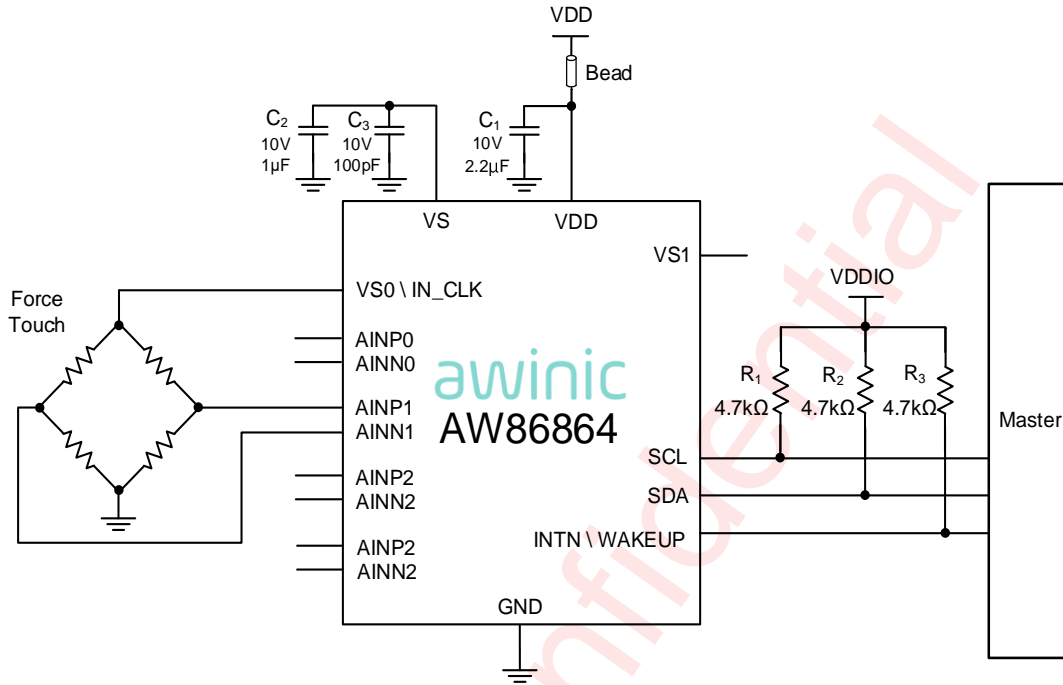
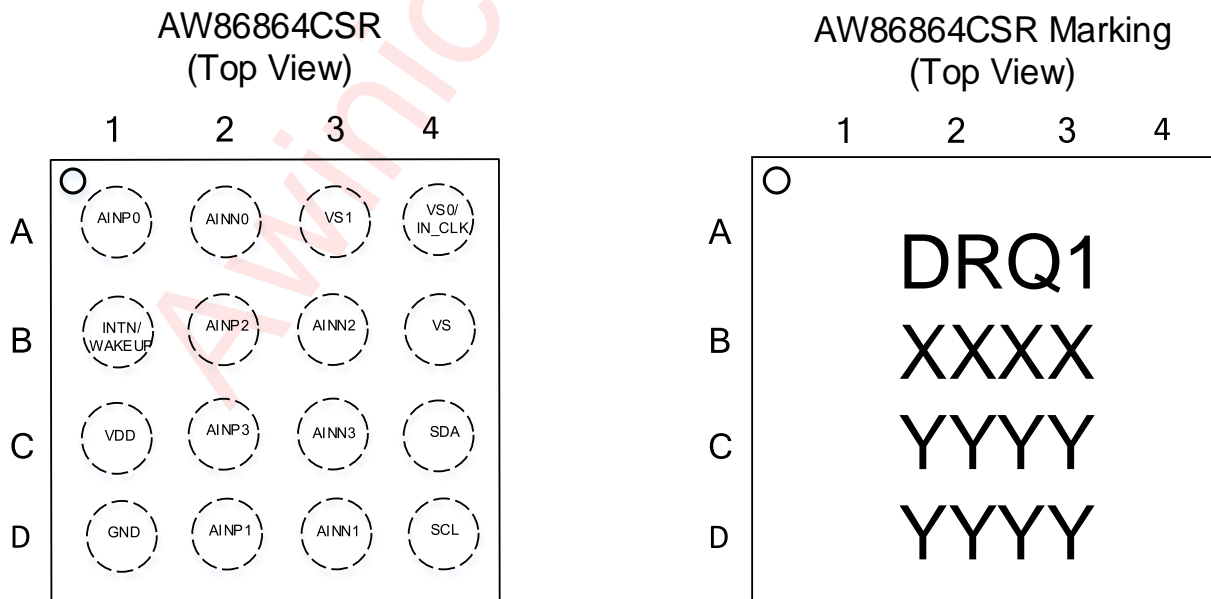

Figure 1 AW86864 Typical Application Circuit

Pin Configuration And Top Mark



DRQ1 - AW86864CSR
XXXX YYYY YYYY - Production Tracing Code

Figure 2 AW86864CSR Pin Configuration And Top Mark

Pin Definition

AW86864CSR Pin Definition

NO.	NAME	DESCRIPTION
A1	AINP0	Sensor Channel 0 Positive Input
A2	AINN0	Sensor Channel 0 Negative Input
A3	VS1	VS1 Regulated output
A4	VS0/IN_CLK	VS0 Regulated output/External Clock Input
B1	INTN/WAKEUP	Interrupt/Wakeup
B2	AINP2	Sensor Channel 2 Positive Input
B3	AINN2	Sensor Channel 2 Negative Input
B4	VS	VS output, need to be connected to 1 μ F capacitor
C1	VDD	Power
C2	AINP3	Sensor Channel 3 Positive Input
C3	AINN3	Sensor Channel 3 Negative Input
C4	SDA	I ² C DATA
D1	GND	Ground
D2	AINP1	Sensor Channel 1 Positive Input
D3	AINN1	Sensor Channel 1 Negative Input
D4	SCL	I ² C CLOCK

Functional Block Diagram

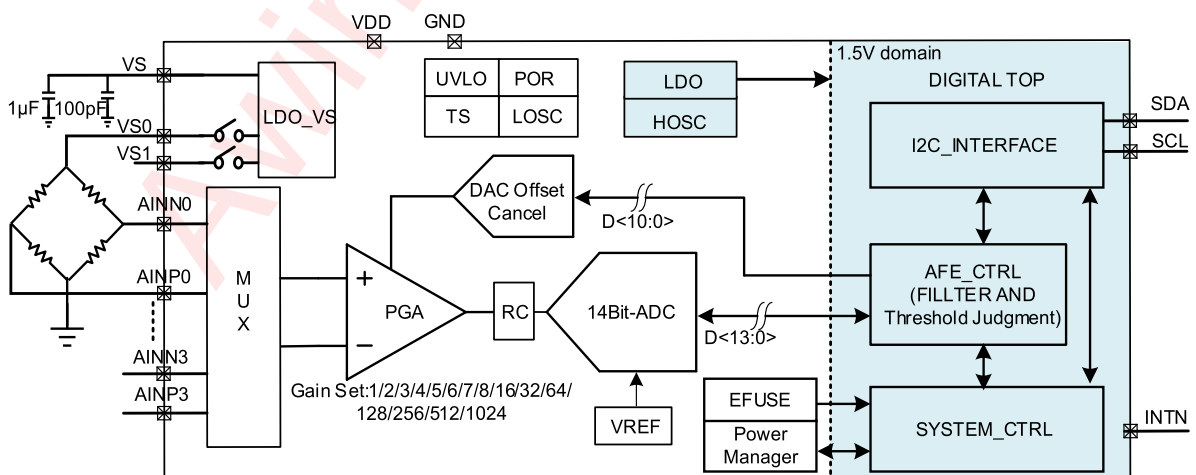

Figure 3 AW86864 Function Block Diagram

Ordering Information

Part Number	Temperature	Package	Marking	Moisture Sensitivity Level	Environmental Information	Delivery Form
AW86864CSR	-40°C~85°C	WLCSP 1.41mm×1.41mm×0.34mm -16B	DRQ1	MSL1	ROHS+HF	4500 units/Tape and Reel

Absolute Maximum Ratings^(NOTE1)

PARAMETERS	RANGE
Supply voltage range V_{DD}	-0.3V to 5.5V
AINP, AINN, INTN	-0.3V to $V_{DD}+0.3V$
Ambient Temperature Range	-40°C to 85°C
Junction-to-ambient thermal resistance θ_{JA}	60°C /W
Maximum operating junction temperature T_{JMAX}	165°C
Storage Temperature Range T_{STG}	-65°C to 150°C
Lead temperature (soldering 10 seconds)	260°C
ESD Rating ^(NOTE 2 3)	
HBM (Human Body Model)	±2kV
CDM(Charge Device Model)	±1.5kV
Latch-up	
Test Condition: JESD78E	+IT: 200mA -IT: -200mA

NOTE1: Conditions out of those ranges listed in "absolute maximum ratings" may cause permanent damages to the device. In spite of the limits above, functional operation conditions of the device should within the ranges listed in "recommended operating conditions". Exposure to absolute-maximum-rated conditions for prolonged periods may affect device reliability.

NOTE2: The human body model is a 100pF capacitor discharged through a 1.5kΩ resistor into each pin. Test method: ESDA/JEDEC JS-001-2017.

NOTE 3: Charge Device Model test method: ESDA/JEDEC JS-002-2018.

Recommended Operating Conditions

Symbol	Parameter	Min.	Typ.	Max.	Unit
VDD	Analog supply voltage	2.6	3.3	5.5	V
C _{VDD}	Input capacitance		2.2		μF
C _{VS}	VS Decoupling capacitor	1			μF
T _A	Operating free-air temperature range	-40	25	85	°C

Awinic Confidential

Electrical Characteristics

VDD=3.3V, T_A=25°C for typical values (unless otherwise noted)

Parameter		Test Conditions	Min	Typical	Max	Unit
VDD	Analog supply voltage		2.6		5.5	V
VIH	Logic input high level		1.35			V
VIL	Logic input low level				0.4	V
VOL	Logic output low level				0.4	V
VOH	Logic output high level		VDD-0.4			V
ILP	Standby current			4		μA
IACT	Active current			1.4		mA
6MHz HOSC						
FHOSC	HOSC working frequency			6		MHz
RHOSC	HOSC Accuracy		-2		2	%
32kHz LOSC						
FLOSC	LOSC working frequency			32		kHz
RLOSC	LOSC Accuracy		-10		10	%
Temperature Sense						
TR	Range		-40		85	°C
TA	Accuracy		-3		3	°C
14bit ADC						
VADIN	Input voltage		0		VREF	V
VREF	ADC Reference voltage			2.8		V
FADC	Conversion rate			150	150	ksps
PGA(Signal input path)						
VCMI	Common mode input voltage		0.1		VDD-1	V
VDMI	Differential input voltage				VDD/ GPGA	V
GPGA	PGA gain		1		1024	
GE	Gain error			10		%
RIN	Differential input impedance			17		MΩ
ISOch-ch	Channel isolation			80		dB
CMRR	Common mode rejection ratio	1.5 mVPP on SIN, 200Hz		105		dB
PSRR	Power supply rejection ratio	200Hz		50		dB
VOS	Input offset voltage			±1		mV
DAC						
RDAC	Resolution			11		bit
MDAC	Monotonic			10		bit

Parameter		Test Conditions	Min	Typical	Max	Unit
VEOSI	Equivalent offset calibration range		- 614×K ⁽¹⁾		+614×K ⁽¹⁾	mV
VS						
VS	VS output voltage		2.4		3.1	V
CVS	VS Decoupling capacitor		1			μF
UVLO						
VUV	Undervoltage detection voltage			2.3		V
VUVH	Under-voltage protection hysteresis voltage			100		mV
POR						
VPOR	Power-on reset voltage			1.6		V

(1) $K = (VS/3) \times K_{pga}$. ($K_{pga} = 1$ ($G_{pga1} \leq 64$), $K_{pga} = 1/2$ ($G_{pga1} = 128$))

I²C Interface

- Only slave mode is supported
- Data bidirectional transmission between master and slaver
- The address is 8 bit, the data bit width is 8 bit
- Support general call, the enable can be configured
- Whether the function of general call responds to ACK can be configured
- Support fast mode and standard mode
- Up to 1MHz communication speed
- The chip device address is 0x6A by default, and the bit is 7bit

Parameter			Fast mode			Super-fast mode			UNIT
No.	Symbol	Name	MIN	TYP	MAX	MIN	TYP	MAX	
1	f_{SCL}	SCL Clock frequency			400			1000	kHz
2	t_{LOW}	SCL Low level Duration	1.3			0.5			μ s
3	t_{HIGH}	SCL High level Duration	0.6			0.26			μ s
4	t_{RISE}	SCL, SDA rise time			0.3			0.12	μ s
5	t_{FALL}	SCL, SDA fall time			0.3			0.12	μ s
6	$t_{SU:STA}$	Setup time SCL to START state	0.6			0.3			μ s
7	$t_{HD:STA}$	(repeat-start) start condition hold time	0.6			0.3			μ s
8	$t_{SU:STO}$	Stop condition setup time	0.6			0.26			μ s
9	t_{BUF}	Time between start and stop condition	1.3			0.5			μ s
10	$t_{SU:DAT}$	SDA setup time	0.1			0.1			μ s
11	$t_{HD:DAT}$	SDA hold time	0			0			ns

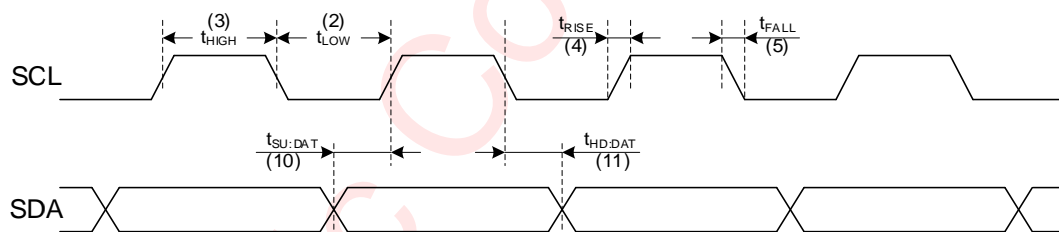

Figure 4 SCL and SDA timing relationships in the data transmission process

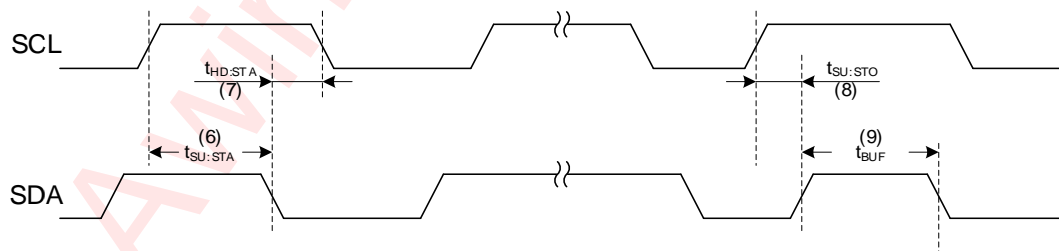

Figure 5 The timing relationship between START and STOP state

WRITE PROCESS

Writing process refers to the master device write data into the slave device. In this process, the transfer direction of the data is always unchanged from the master device to the slave device. All acknowledge bits are transferred by the slave device, in particular, the device as the slave device, the transmission process in accordance with the following steps, as shown in Figure 6.

Master device generates START state. The START state is produced by pulling the data line SDA to a low

level when the clock SCL signal is a high level.

Master device transmits the 7-bits device address of the slave device, followed by the "read / write" flag (flag $R/\overline{W} = 0$);

The slave device asserts an acknowledgment bit (ACK) to confirm whether the device address is correct;

The master device transmits the 8-bit register address to which the first data byte will written;

The slave device asserts an acknowledgment (ACK) bit to confirm the register address is correct;

Master sends 8 bits of data to register which needs to be written;

The slave device asserts an acknowledgment bit (ACK) to confirm whether the data is sent successfully;

If the master device needs to continue transmitting data by sending another pair of data bytes, just need to repeat the sequence from step 6. In the latter case, the targeted register address will have been auto-incremented by the device.

The master device generates the STOP state to end the data transmission.

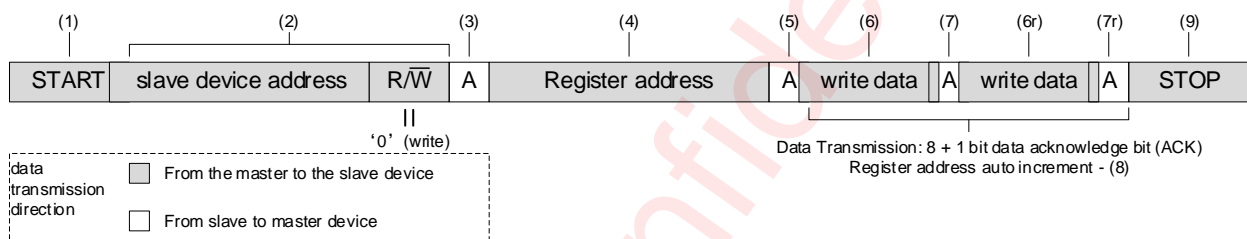

Figure 6 Writing process

READ PROCESS

Reading process refers to the slave device reading data back to the master device. In this process, the direction of data transmission will change. Before and after the change, the master device sends START state and slave address twice, and sends the opposite "read/write" flag. In particular, AW86864 as the slave device, the transmission process carried out by following steps listed in Figure 7.

Master device asserts a start condition;

Master device transmits the 7 bits address of the device, and followed by a "read / write" flag ($R/\overline{W} = 0$);

The slave device asserts an acknowledgment bit (ACK) to confirm whether the device address is correct;

The master device transmits the register address to make sure where the first data byte will read;

The slave device asserts an acknowledgment (ACK) bit to confirm whether the register address is correct or not;

The master device restarts the data transfer process by continuously generating STOP state and START state or a separate Repeated START;

Master sends 7-bits address of the slave device and followed by a read / write flag (flag $R/\overline{W} = 1$) again;

The slave device asserts an acknowledgment (ACK) bit to confirm whether the register address is correct or not;

Master transmits 8 bits of data to register which needs to be read;

The slave device sends an acknowledgment bit (ACK) to confirm whether the data is sent successfully;

The device automatically increment register address once after sent each acknowledge bit (ACK);

The master device generates the STOP state to end the data transmission.

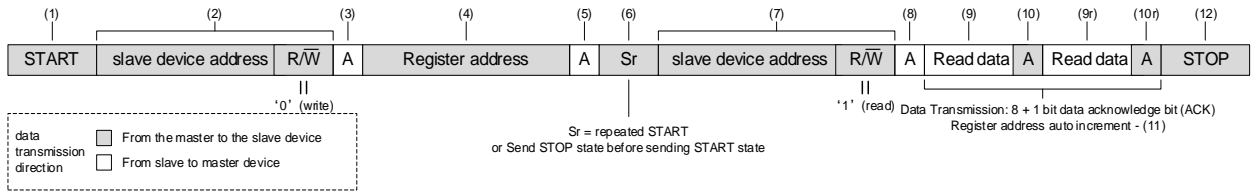

Figure 7 Reading process

Detailed Functional Description

Power On Sequence

The power on sequence of this device is illustrated in the following figure:

Parameter		Value			Unit
Symbol	Name	Min	Typical	Max	
t_{WAIT}	Waiting time for communication with I ² C after power on	3			ms
PUR	Instant Power-up rate	1.6			mV/ μ s
t_{FALL}	Falling time of power supply	0			ms
t_{LOW}	Time between power off and power on	50*			ms

*The t_{LOW} is to make sure the power supply below 100mV after power off.

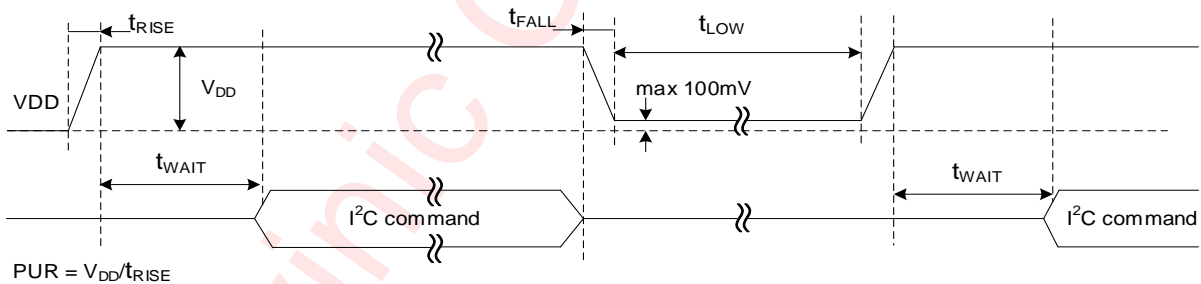

Figure 8 Power On Sequence

Clock

Source of system clock: internal high-speed clock (HOSC) and external pin clock (EOSC, multiplexing VS0 pin). LOSC is the clock of low power consumption module, which is used for SWDT timing wake-up. The osc_clk_sel signal is used to select HOSC or EOSC. The system clock is obtained by frequency division of the selected clock.

Before configuring the clock selection signal, the clock enable should be configured first. The system will give priority to the enabled clock. ADC clock uses the system clock.

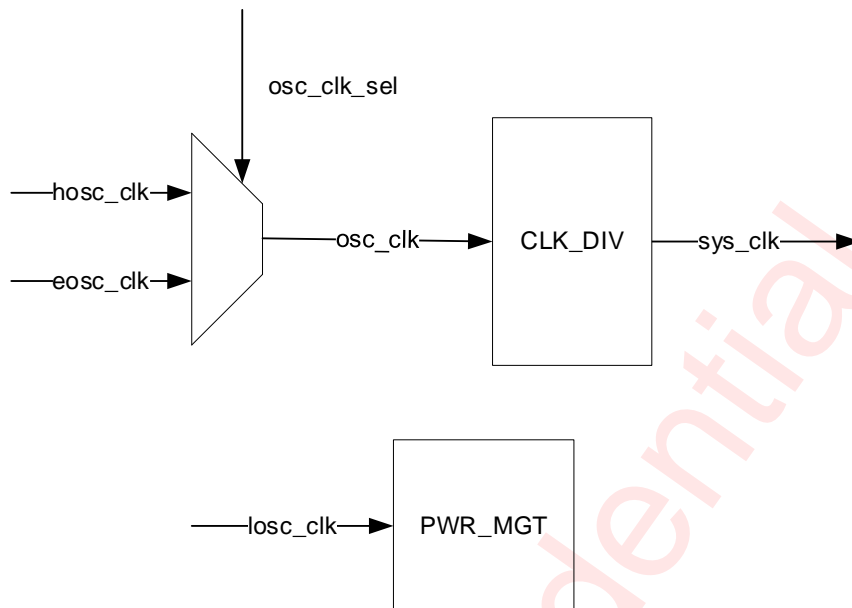

Figure 9 Clock Tree

Reset

AW86864 has three kinds of reset signal: power on reset (POR), whole chip reset (Chip Reset) and soft reset of digital circuit (Soft Reset). Soft Reset resets the system control module and AFE module.

The POR is effective after the chip is powered on, and the reset signal of the system is generated by the control circuit of the power on sequence.

System Control and PAD

Master can configure the way of chip entering low power consumption mode and clearing wake-up request through I²C. After chip is awakened, the wake-up request signal needs to be cleared if the system wants to enter low power consumption mode again. System control module can configure the delay time of automatic trigger AFE in the operation state, and the AFE will be triggered immediately after entering operation state.

The interrupts produced in the operation state, including ADC interrupt, comparator interrupt, algorithm interrupt and so on, can be output through interrupt pin PAD_INTN. The output enable of each interrupt can be configured and the effective level of interrupt output can be configured. PAD_INTN is used as wake-up pin in low power consumption mode and its wake-up effective level can be configured. It should be noted that since the wake-up function multiplexes PAD_INTN, the effective level of the interrupt output should be consistent with the wake-up active level, and the recommended configuration is low level active (default configuration).

PAD_SCL, PAD_SDA, PAD_INTN and PAD_VS0 are multiplexed as IO pins, and its analog characteristics can be configured through registers.

- PAD_SCL is open drain output. There is no pull-up resistor or pull-down resistor in the chip. The input can be configured with the enable of Schmidt trigger and fast mode. It is the SCL pin of I²C interface.
- PAD_SDA is open drain output. There is no pull-up resistor or pull-down resistor in the chip. The input can be configured with the enable of Schmidt trigger and fast mode. It is the SDA pin of I²C interface.
- PAD_INTN is open drain output. There is no pull-up resistor or pull-down resistor in the chip. The input can be configured with the enable of Schmidt trigger and fast mode. It is the interrupt output pin and wake-up pin.

- PAD_VS0 can be configured as open drain or push-pull output. The input can be configured with the enable of Schmidt trigger and fast mode. In normal operation, it is the power supply pin of the sensor, which can be multiplexed as input pin of external clock.

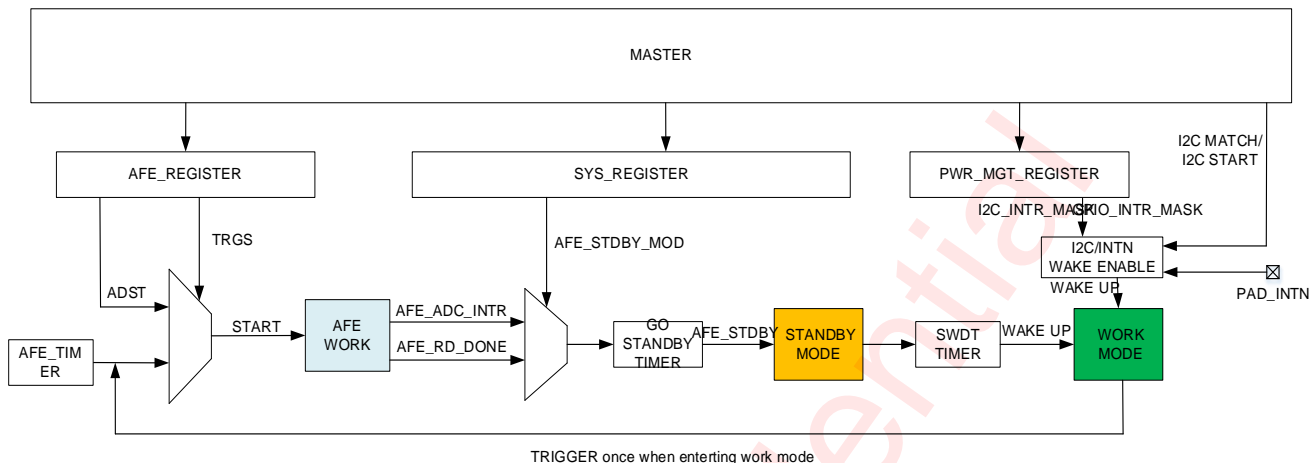

Figure 10 System Workflow

Low Power Consumption and SWDT

When the chip enters low power consumption mode, it can be awakened by SWDT in the 5V domain, or can be configured to wake up through I²C and PAD_INTN. HOSC and VS are automatically turned off, LOSC and digital power supply LDO can choose to turn off.

- Four low-power mode
- Send I²C command to enter low-power mode immediately
- Two ways to enter low-power mode after the delay T1
 - ADC interrupt trigger
 - Trigger after reading AFE data register
- SWDT
 - Working under 5V domain power
 - SWDT still work when turn off LDO
 - The clock source is LOSC, 32kHz
 - 16 bit counter, wake up time T2 configurable

* $T1 = GO_STDBY_DLY[23:0]/F_{sys}$ $T2 = LD_SWDT_CNT[15:0]/F_{clk} = LD_SWDT_CNT[15:0]*31.25\text{ ms}$
 F_{sys} indicates the frequency of system clock(can be configured by HOSC_SEL and CLK_DIV register)
 F_{clk} indicates the frequency of LOSC(32kHz)

Low power consumption mode	Deep Sleep1 LDO open LOSC open	Deep Sleep2 LDO open LOSC close	Deep Sleep3 LDO close LOSC open	Deep Sleep4 LDO close LOSC close
HOSC	close	close	close	close
LOSC	open	close	open	close
LDO	open	open	close	close

SWDT	open	close	open	close
AFE module (PGA+ADC+DAC)	Switch is configurable	Switch is configurable	close	close
AFE+SYS configuration	Retain configuration	Retain configuration	Lose configuration	Lose configuration
Awakening conditions	I ² C(configurable) PAD_INTN(configurable) SWDT(If LOSC is turned off, SWDT will not work) In Deep Sleep2 and Deep Sleep4 mode, if both I ² C wake-up and PAD_INTN wake-up are turned off, LOSC and SWDT wake-up will be forced to open.			

AFE

The AFE module include two PGAs, one 11 bit DAC and one 14-bit ADC

- Provide different configurations for 6 logical channels, including 2 external sensor inputs and 4 internal inputs(VS/GND channels for external impedance self-checking, the single-ended and differential channels are used to measure temperature)
- Provide 6 working modes
 - Single conversion mode : Complete a conversion on the designated channel
 - Single cycle scan mode : Complete a conversion on all designated channels
 - Finite cycle scan mode1 : Each channel switches to the next channel after a specified number of conversions
 - Finite cycle scan mode2 : Each channel converts once and then enters the next channel in turn, converting a specified number of times in total
 - Infinite scan mode : Continuously execute single-cycle scan mode until software stops A/D conversion
 - Burst Mode : Continue on a single designated channel and store the results in FIFO in sequence
- Conditions for starting A/D conversion
 - Software writes 1 to ADST bit
 - Timer trigger (can be configured to turn off enable)
- The conversion result can be compared with the specified value, the user can set whether to generate an interruption when matching
- Built-in two press detection modules, which can detect the press events of two channels at the same time and generate interruptions.
- Built-in Level 2 PGA, The first stage PGA gain coefficient can be configured as 1/16/32/64/128, The second stage PGA gain coefficient can be configured as 1/2/3/4/5/6/7/8
- Built-in 11-bit DAC for offset voltage calibration
- Built-in 14 bit SAR ADC, up to 150kHz SPS
- ADC reference voltage VREF is configurable: 2.4V/2.8V/3.0V/3.1V/AVDD

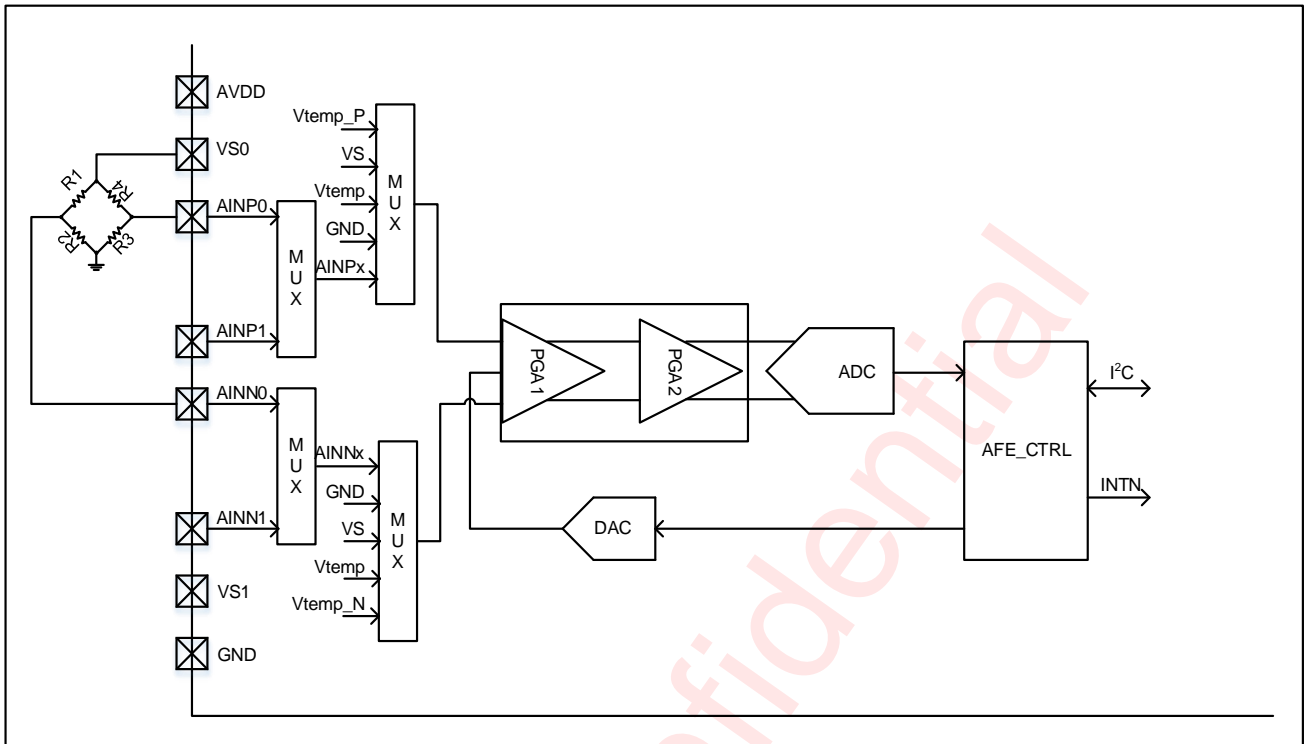

Figure 11 AFE Function Block Diagram

Register Configuration

Register List

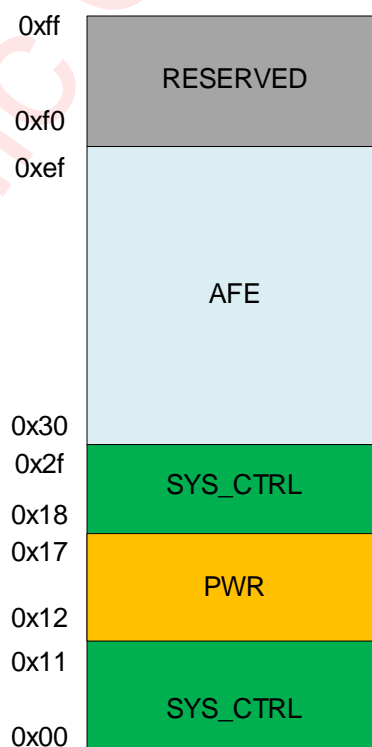

Figure 12 AW86864 Register Address Distribution

SYS				
ADDR	NAME	R/W	Description	Default
0x00	CHIPID	RO	Chip id register	0x64
0x01	YEAR	RO	Chip year register	0x20
0x02	MONTH	RO	Chip month register	0x0a
0x03	DATE	RO	Chip date register	0x25
0x04	SYS_BLANK	R/W	System blank register	0x55
0x05	WR_UNLOCK	R/W	System register write unlock register	0x00
0x06	RESERVED	R/W	Reserved	0x00
0x07	SYS_ST	RO	System state register	0x01
0x08	RESERVED	RO	Reserved	0x00
0x09	RESERVED	RO	Reserved	0x00
0x0a	RESERVED	RO	Reserved	0x00
0x0b	RESERVED	RO	Reserved	0x00
0x0c	RESERVED	RO	Reserved	0x00
0x0d	RESERVED	RO	Reserved	0x00
0x0e	RESERVED	RO	Reserved	0x00
0x0f	DAC_EN_CFG	R/W	DAC enable configuration register	0x00
0x10	CLK_DIV0	R/W	Clk division data register	0x01
0x11	CLK_CFG	R/W	Clk configuration register	0x0c
0x18	GO_STDBU_DLY2	R/W	Go standby delay time register[23:16]	0x03
0x19	GO_STDBU_DLY1	R/W	Go standby delay time register[15:8]	0xff
0x1a	GO_STDBU_DLY0	R/W	Go standby delay time register[7:0]	0xff
0x1b	GO_STDBY_CFG	R/W	Go standby configuration register	0x00
0x1c	AFE_TIMER2	R/W	Trigger AFE timer register[23:16]	0x03
0x1d	AFE_TIMER1	R/W	Trigger AFE timer register[15:8]	0xff
0x1e	AFE_TIMER0	R/W	Trigger AFE timer register[7:0]	0xff
0x1f	INTR_MASK	R/W	Interrupt mask register	0x01
0x20	INTR_STAT	R/W	Interrupt state register	0x00
0x21	ANA_ADJ_CFG	R/W	Analog adjustment configuration register	0x22
0x22	TEMP_VS_SEL	R/W	Analog temperature and VS mode configuration register	0x01
0x25	PAD_EN_OD	R/W	Pad open drain enable register	0x03
0x26	PD_PU_RES	R/W	Pad pull up or pull down resistance	0x00
0x27	PAD_ADJ	R/W	Pad adjustment configuration register	0x30
0x28	SR_CTRL	R/W	Pad output delay control register	0x22
0x29	FAST_CTRL	R/W	Pad input fast enable register	0x00
0x2a	EN_SCHMITT	R/W	Pad input Schmitt enable register	0x0f
0x2b	ANA_EN_CFG	R/W	Analog module enable configuration register	0x0b
0x2c	UVLO_CFG	RO	UVLO module configuration register	0x00
0x2f	RST_CFG	R/W	Reset configuration register	0x00
PWR				

ADDR	NAME	R/W	Description	Default
0x12	SWDT_CNT1	RO	SWDT counter current number register[15:8]	0x0b
0x13	SWDT_CNT0	RO	SWDT counter current number register[7:0]	0xff
0x14	LD_SWDT_CNT1	R/W	SWDT delay counter load data register[15:8]	0x0b
0x15	LD_SWDT_CNT0	R/W	SWDT delay counter load data register[7:0]	0xff
0x16	LD_SWDT_CFG	R/W	Load SWDT configuration register	0x00
0x17	STDBY_CFG	R/W	Standby state configuration register	0x03
AFE				
ADDR	NAME	R/W	Description	Default
0x30	ADCH0CR0_0	R/W	channel 0 ADC configuration register0[7:0]	0x00
0x31	ADCH0CR0_1	R/W	channel 0 ADC configuration register0[15:8]	0x37
0x32	ADCH0CR0_2	R/W	channel 0 ADC configuration register0[23:16]	0x10
0x33	ADCH0CR0_3	R/W	channel 0 ADC configuration register0[31:24]	0x10
0x34	ADCH0CR1_0	R/W	channel 0 ADC configuration register1[7:0]	0x23
0x35	ADCH0CR1_1	R/W	channel 0 ADC configuration register1[15:8]	0x00
0x36	ADCH0CR1_2	R/W	channel 0 ADC configuration register1[23:16]	0x64
0x37	ADCH0CR1_3	R/W	channel 0 ADC configuration register1[31:24]	0x43
0x38	DACH0CR_0	R/W	channel 0 DAC configuration register[7:0]	0x00
0x39	DACH0CR_1	R/W	channel 0 DAC configuration register[15:8]	0x09
0x3A	DACH0CR_2	RO	channel 0 DAC configuration register[23:16]	0x00
0x3B	DACH0CR_3	RO	channel 0 DAC configuration register[31:24]	0x00
0x3C	DACH0DR_0	R/W	channel 0 DAC data register[7:0]	0x00
0x3D	DACH0DR_1	R/W	channel 0 DAC data register[15:8]	0x00
0x3E	DACH0DR_2	R/W	channel 0 DAC data register[23:16]	0x00
0x3F	DACH0DR_3	R/W	channel 0 DAC data register[31:24]	0x00
0x40	ADCH1CR0_0	R/W	channel 1 ADC configuration register0[7:0]	0x00
0x41	ADCH1CR0_1	R/W	channel 1 ADC configuration register0[15:8]	0x37
0x42	ADCH1CR0_2	R/W	channel 1 ADC configuration register0[23:16]	0x10
0x43	ADCH1CR0_3	R/W	channel 1 ADC configuration register0[31:24]	0x10
0x44	ADCH1CR1_0	R/W	channel 1 ADC configuration register1[7:0]	0x23
0x45	ADCH1CR1_1	R/W	channel 1 ADC configuration register1[15:8]	0x00
0x46	ADCH1CR1_2	R/W	channel 1 ADC configuration register1[23:16]	0x64
0x47	ADCH1CR1_3	R/W	channel 1 ADC configuration register1[31:24]	0x43
0x48	DACH1CR_0	R/W	channel 1 DAC configuration register[7:0]	0x00
0x49	DACH1CR_1	R/W	channel 1 DAC configuration register[15:8]	0x09
0x4A	DACH1CR_2	RO	channel 1 DAC configuration register[23:16]	0x00

0x4B	DACH1CR_3	RO	channel 1 DAC configuration register[31:24]	0x00
0x4C	DACH1DR_0	R/W	channel 1 DAC data register[7:0]	0x00
0x4D	DACH1DR_1	R/W	channel 1 DAC data register[15:8]	0x00
0x4E	DACH1DR_2	R/W	channel 1 DAC data register[23:16]	0x00
0x4F	DACH1DR_3	R/W	channel 1 DAC data register[31:24]	0x00
0x50	ADCH2CR0_0	R/W	channel 2 ADC configuration register0[7:0]	0x00
0x51	ADCH2CR0_1	R/W	channel 2 ADC configuration register0[15:8]	0x37
0x52	ADCH2CR0_2	R/W	channel 2 ADC configuration register0[23:16]	0x10
0x53	ADCH2CR0_3	R/W	channel 2 ADC configuration register0[31:24]	0x10
0x54	ADCH2CR1_0	R/W	channel 2 ADC configuration register1[7:0]	0x23
0x55	ADCH2CR1_1	R/W	channel 2 ADC configuration register1[15:8]	0x00
0x56	ADCH2CR1_2	R/W	channel 2 ADC configuration register1[23:16]	0x64
0x57	ADCH2CR1_3	R/W	channel 2 ADC configuration register1[31:24]	0x43
0x58	DACH2CR_0	R/W	channel 2 DAC configuration register[7:0]	0x00
0x59	DACH2CR_1	R/W	channel 2 DAC configuration register[15:8]	0x09
0x5A	DACH2CR_2	RO	channel 2 DAC configuration register[23:16]	0x00
0x5B	DACH2CR_3	RO	channel 2 DAC configuration register[31:24]	0x00
0x5C	DACH2DR_0	R/W	channel 2 DAC data register[7:0]	0x00
0x5D	DACH2DR_1	R/W	channel 2 DAC data register[15:8]	0x00
0x5E	DACH2DR_2	R/W	channel 2 DAC data register[23:16]	0x00
0x5F	DACH2DR_3	R/W	channel 2 DAC data register[31:24]	0x00
0x60	ADCH3CR0_0	R/W	channel 3 ADC configuration register0[7:0]	0x00
0x61	ADCH3CR0_1	R/W	channel 3 ADC configuration register0[15:8]	0x37
0x62	ADCH3CR0_2	R/W	channel 3 ADC configuration register0[23:16]	0x10
0x63	ADCH3CR0_3	R/W	channel 3 ADC configuration register0[31:24]	0x10
0x64	ADCH3CR1_0	R/W	channel 3 ADC configuration register1[7:0]	0x23
0x65	ADCH3CR1_1	R/W	channel 3 ADC configuration register1[15:8]	0x00
0x66	ADCH3CR1_2	R/W	channel 3 ADC configuration register1[23:16]	0x64
0x67	ADCH3CR1_3	R/W	channel 3 ADC configuration register1[31:24]	0x43
0x68	DACH3CR_0	R/W	channel 3 DAC configuration register[7:0]	0x00
0x69	DACH3CR_1	R/W	channel 3 DAC configuration register[15:8]	0x09
0x6A	DACH3CR_2	RO	channel 3 DAC configuration register[23:16]	0x00
0x6B	DACH3CR_3	RO	channel 3 DAC configuration register[31:24]	0x00
0x6C	DACH3DR_0	R/W	channel 3 DAC data register[7:0]	0x00
0x6D	DACH3DR_1	R/W	channel 3 DAC data register[15:8]	0x00

0x6E	DACH3DR_2	R/W	channel 3 DAC data register[23:16]	0x00
0x6F	DACH3DR_3	R/W	channel 3 DAC data register[31:24]	0x00
0x70	ADCH4CR0_0	R/W	channel 4 ADC configuration register0[7:0]	0x00
0x71	ADCH4CR0_1	R/W	channel 4 ADC configuration register0[15:8]	0x37
0x72	ADCH4CR0_2	R/W	channel 4 ADC configuration register0[23:16]	0x10
0x73	ADCH4CR0_3	R/W	channel 4 ADC configuration register0[31:24]	0x10
0x74	ADCH4CR1_0	R/W	channel 4 ADC configuration register1[7:0]	0x23
0x75	ADCH4CR1_1	R/W	channel 4 ADC configuration register1[15:8]	0x00
0x76	ADCH4CR1_2	R/W	channel 4 ADC configuration register1[23:16]	0x64
0x77	ADCH4CR1_3	R/W	channel 4 ADC configuration register1[31:24]	0x43
0x78	DACH4CR_0	R/W	channel 4 DAC configuration register[7:0]	0x00
0x79	DACH4CR_1	R/W	channel 4 DAC configuration register[15:8]	0x09
0x7A	DACH4CR_2	RO	channel 4 DAC configuration register[23:16]	0x00
0x7B	DACH4CR_3	RO	channel 4 DAC configuration register[31:24]	0x00
0x7C	DACH4DR_0	R/W	channel 4 DAC data register[7:0]	0x00
0x7D	DACH4DR_1	R/W	channel 4 DAC data register[15:8]	0x00
0x7E	DACH4DR_2	R/W	channel 4 DAC data register[23:16]	0x00
0x7F	DACH4DR_3	R/W	channel 4 DAC data register[31:24]	0x00
0x80	ADCH5CR0_0	R/W	channel 5 ADC configuration register0[7:0]	0x00
0x81	ADCH5CR0_1	R/W	channel 5 ADC configuration register0[15:8]	0x37
0x82	ADCH5CR0_2	R/W	channel 5 ADC configuration register0[23:16]	0x10
0x83	ADCH5CR0_3	R/W	channel 5 ADC configuration register0[31:24]	0x10
0x84	ADCH5CR1_0	R/W	channel 5 ADC configuration register1[7:0]	0x23
0x85	ADCH5CR1_1	R/W	channel 5 ADC configuration register1[15:8]	0x00
0x86	ADCH5CR1_2	R/W	channel 5 ADC configuration register1[23:16]	0x64
0x87	ADCH5CR1_3	R/W	channel 5 ADC configuration register1[31:24]	0x43
0x88	DACH5CR_0	R/W	channel 5 DAC configuration register[7:0]	0x00
0x89	DACH5CR_1	R/W	channel 5 DAC configuration register[15:8]	0x09
0x8A	DACH5CR_2	RO	channel 5 DAC configuration register[23:16]	0x00
0x8B	DACH5CR_3	RO	channel 5 DAC configuration register[31:24]	0x00
0x8C	DACH5DR_0	R/W	channel 5 DAC data register[7:0]	0x00
0x8D	DACH5DR_1	R/W	channel 5 DAC data register[15:8]	0x00
0x8E	DACH5DR_2	R/W	channel 5 DAC data register[23:16]	0x00
0x8F	DACH5DR_3	R/W	channel 5 DAC data register[31:24]	0x00
0xB0	ADCH0DR_0	RO	channel 0 ADC data register[7:0]	0x00

0xB1	ADCH0DR_1	RO	channel 0 ADC data register[15:8]	0x00
0xB2	ADCH1DR_0	RO	channel 1 ADC data register[7:0]	0x00
0xB3	ADCH1DR_1	RO	channel 1 ADC data register[15:8]	0x00
0xB4	ADCH2DR_0	RO	channel 2 ADC data register[7:0]	0x00
0xB5	ADCH2DR_1	RO	channel 2 ADC data register[15:8]	0x00
0xB6	ADCH3DR_0	RO	channel 3 ADC data register[7:0]	0x00
0xB7	ADCH3DR_1	RO	channel 3 ADC data register[15:8]	0x00
0xB8	ADCH4DR_0	RO	channel 4 ADC data register[7:0]	0x00
0xB9	ADCH4DR_1	RO	channel 4 ADC data register[15:8]	0x00
0xBA	ADCH5DR_0	RO	channel 5 ADC data register[7:0]	0x00
0xBB	ADCH5DR_1	RO	channel 5 ADC data register[15:8]	0x00
0xC0	ADMCR_0	R/W	ADC mode control register[7:0]	0x4b
0xC1	ADMCR_1	R/W	ADC mode control register[15:8]	0x00
0xC2	ADMCR_2	R/W	ADC mode control register[23:16]	0x0a
0xC3	ADMCR_3	RO	ADC mode control register[31:24]	0x00
0xC4	ADTDR_0	R/W	ADC trigger delay control register[7:0]	0xff
0xC5	ADTDR_1	R/W	ADC trigger delay control register[15:8]	0x01
0xC6	ADTDR_2	RO	ADC trigger delay control register[23:16]	0x00
0xC7	ADTDR_3	RO	ADC trigger delay control register[31:24]	0x00
0xC8	ADSR_0	R/W	ADC status register[7:0]	0x00
0xC9	ADSR_1	RO	ADC status register[15:8]	0x00
0xCA	ADSR_2	RO	ADC status register[23:16]	0x00
0xCB	ADSR_3	RO	ADC status register[31:24]	0x00
0xCC	ADCMPCR0_0	R/W	ADC compare register0[7:0]	0x00
0xCD	ADCMPCR0_1	R/W	ADC compare register0[15:8]	0x00
0xCE	ADCMPCR0_2	R/W	ADC compare register0[23:16]	0x00
0xCF	ADCMPCR0_3	R/W	ADC compare register0[31:24]	0x00
0xD0	ADCMPCR1_0	R/W	ADC compare register1[7:0]	0x00
0xD1	ADCMPCR1_1	R/W	ADC compare register1[15:8]	0x00
0xD2	ADCMPCR1_2	R/W	ADC compare register1[23:16]	0x00
0xD3	ADCMPCR1_3	R/W	ADC compare register1[31:24]	0x00
0xD4	ADCHEN_0	R/W	channel enable register[7:0]	0x03
0xD5	ADCHEN_1	RO	channel enable register[15:8]	0x00
0xD6	ADCHEN_2	RO	channel enable register[23:16]	0x00
0xD7	ADCHEN_3	RO	channel enable register[31:24]	0x00

0xD8	DAOSDR_0	RO	DAC offset calibration register[7:0]	0x00
0xD9	DAOSDR_1	RO	DAC offset calibration register[15:8]	0x00
0xDA	DAOSDR_2	R/W	DAC offset calibration register[23:16]	0x00
0xDB	DAOSDR_3	R/W	DAC offset calibration register[31:24]	0x00
0xDC	FACH0CR0	R/W	force algorithm channel 0 compare register0	0x00
0xDD	FACH0CR1	R/W	force algorithm channel 0 compare register1	0x00
0xDE	FACH0CR2	R/W	force algorithm channel 0 compare register2	0x00
0xDF	FACH1CR0	R/W	force algorithm channel 1 compare register0	0x00
0xE0	FACH1CR1	R/W	force algorithm channel 1 compare register1	0x00
0xE1	FACH1CR2	R/W	force algorithm channel 1 compare register2	0x00
0xE2	FACH2CR0	R/W	force algorithm channel 2 compare register0	0x00
0xE3	FACH2CR1	R/W	force algorithm channel 2 compare register1	0x00
0xE4	FACH2CR2	R/W	force algorithm channel 2 compare register2	0x00
0xE5	FACH3CR0	R/W	force algorithm channel 3 compare register0	0x00
0xE6	FACH3CR1	R/W	force algorithm channel 3 compare register1	0x00
0xE7	FACH3CR2	R/W	force algorithm channel 3 compare register2	0x00
0xE8	FACHTR0	R/W	force algorithm compare event time register0	0x00
0xE9	FACHTR1	R/W	force algorithm compare event time register1	0x00
0xEA	FACFTR	R/W	force algorithm compare filter time register	0x00
0xEB	FACR0	R/W	force algorithm control register0	0x00
0xEC	FACR1	R/W	force algorithm control register1	0x00
0xED	FAMR	R/W	force algorithm mode register	0x00
0xEE	FASR0	RO	force algorithm status register0	0x00
0xEF	FASR1	RO	force algorithm status register1	0x00

Register Detailed Description

CHIPID: Address(0x00)				
Bit	Symbol	R/W	Description	Default
7:0	CHIP_ID_0	RO	chip identification register	0x64

YEAR: Address(0x01)				
Bit	Symbol	R/W	Description	Default
7:0	YEAR_0	RO	chip year register	0x20

MONTH: Address(0x02)				
Bit	Symbol	R/W	Description	Default
7:0	MONTH_0	RO	chip month register	0x0a

DATE: Address(0x03)				
Bit	Symbol	R/W	Description	Default
7:0	DATE_0	RO	chip date register	0x25

SYS_BLANK: Address(0x04)				
Bit	Symbol	R/W	Description	Default
7:0	SYS_BLANK_0	RW	system blank register	0x55

WR_UNLOCK: Address(0x05)				
Bit	Symbol	R/W	Description	Default
7:1	WR_UNLOCK_0	RW	system register write unlock register, write 0xa5 to unlock the system register(control address range:0x00-0x2F)	0x0
0	UNLOCK_STAT	RW	system write unlocked state 1: unlocked 0:locked	0x0

RESERVED: Address(0x06)				
Bit	Symbol	R/W	Description	Default
7:0	Reserved	RO	Not used	0x00

SYS_ST: Address(0x07)				
Bit	Symbol	R/W	Description	Default
7	EF_LOCK	RO	efuse write lock state 1: locked 0:unlocked	0x0
6	EF_TRIM_FLAG	RO	efuse trim ready flag state 1: ready 0:not ready	0x0
5	EOSC_CLK_OK	RO	EOSC start work flag state 1: ready 0:not ready	0x0
4	HOSC_CLK_OK	RO	HOSC start work flag state 1: working 0:not working	0x0
3	VBG_OK	RO	Vbg ready flag state 1: ready 0:not ready	0x0
2:1	SYS_CTR_STATE	RO	system control current state 00:standby state 01:work state 10:power up state	0x0
0	INIT_STATE	RO	power up initial state 1:work state after power up 0:standby state after power up	0x1

RESERVED: Address(0x08)				
Bit	Symbol	R/W	Description	Default
7:0	Reserved	RO	Not used	0x00

HOSC_SEL: Address(0x09)				
Bit	Symbol	R/W	Description	Default

7	HOSC_SEL	RW	HOSC frequency configuration register, 1: 8MHz 0: 6MHz	0x0
6:0	Reserved	RO	Not used	0x00

RESERVED: Address(0x0A)

Bit	Symbol	R/W	Description	Default
7:0	Reserved	RO	Not used	0x00

RESERVED: Address(0x0B)

Bit	Symbol	R/W	Description	Default
7:0	Reserved	RO	Not used	0x00

RESERVED: Address(0x0C)

Bit	Symbol	R/W	Description	Default
7:0	Reserved	RO	Not used	0x00

RESERVED: Address(0x0D)

Bit	Symbol	R/W	Description	Default
7:0	Reserved	RO	Not used	0x00

RESERVED: Address(0x0E)

Bit	Symbol	R/W	Description	Default
7:0	Reserved	RO	Not used	0x00

DAC_EN_CFG: Address(0x0F)

Bit	Symbol	R/W	Description	Default
7:4	Reserved	RO	Not used	0
3	SYS_EN_ADC	RW	adc start enable 1: enable 0 :disable	0x0
2	EN_PGA	RW	pga start enable 1: enable 0 :disable	0x0
1	EN_DAC	RW	dac start enable 1: enable 0 :disable	0x0
0	EN_DAC_CODE	RW	dac code standby mode enable 0: 11'd0 when standby mode 1: unchange when standby mode	0x0

CLK_DIV0: Address(0x10)

Bit	Symbol	R/W	Description	Default
7:0	CLK_DIV	RW	system clock frequency division counter, no frequency division when 0 or 1, $F_{sys}=F_{hosc}/ CLK_DIV$	0x01

CLK_CFG: Address(0x11)

Bit	Symbol	R/W	Description	Default
-----	--------	-----	-------------	---------

7	Reserved	RO	Not used	0
6	OSC_CLK_SEL	RO	current system clock selection, read only 1: external clock 0: hosc clock	0x0
5	OSC_CLK_OK	RO	selection clock ready flag register, read only 1: ready 0: not ready	0x0
4	OSC_SEL	RW	system clock selection configuration 1: external clock 0: hosc clock	0x0
3	EN_EOSC	RW	external clock enable, 1: enable 0: disable	0x1
2	EN_HOSC	RW	hosc clock enable, 1: enable 0: disable	0x1
1:0	Reserved	RO	Not used	0

SWDT_CNT1: Address(0x12)				
Bit	Symbol	R/W	Description	Default
7:0	SWDT_CNT1_0	RO	The [15:8] bit of swdt counter current value, read only	0x0b

SWDT_CNT0: Address(0x13)				
Bit	Symbol	R/W	Description	Default
7:0	SWDT_CNT0_0	RO	The [7:0] bit of swdt counter current value, read only	0xff

LD_SWDT_CNT1: Address(0x14)				
Bit	Symbol	R/W	Description	Default
7:0	LD_SWDT_CNT1_0	RW	The [15:8] bit of swdt counter configuration register LD_SWDT_CNT; swdt wake up time = LD_SWDT_CNT[15:0]/ F _{clk}	0x0b

LD_SWDT_CNT0: Address(0x15)				
Bit	Symbol	R/W	Description	Default
7:0	LD_SWDT_CNT0_0	RW	The [7:0] bit of swdt counter configuration register LD_SWDT_CNT; swdt wake up time = LD_SWDT_CNT[15:0]/ F _{clk}	0xff

LD_SWDT_CFG: Address(0x16)				
Bit	Symbol	R/W	Description	Default
7	LDO_OK	RO	LDO state register, 1 when active	0x0
6	I2C_INTR_MASK	RW	I ² C interrupt mask, 1 enable I ² C wake up	0x0
5	GPIO_INTR_MASK	RW	gpio interrupt mask, 1 enable gpio wake up	0x0
4	EN_VLDOH	RW	LDO high voltage enable, 1:LDO voltage increase 100mV	0x0

3	CTRL_ACTI	RW	LDO active state output current configuration 1: decrease 35 μ A 0: normal	0x0
2	EN_LOAD	RW	work state load swdt counter enable 0: disable 1: enable	0x0
1	EN_SWDT	RW	work state swdt enable 0: disable 1: enable	0x0
0	EN_SWDT_INTR	RW	swdt interrupt enable 0: disable 1: enable	0x0

STDBY_CFG: Address(0x17)				
Bit	Symbol	R/W	Description	Default
7	PWR_ST_WORK	RO	power manage module state, 1:work state 0:standby state	0x0
6	SWDT_WAKEUP_REQ	RO	swdt wake up request	0x0
5	GPIO_WAKEUP_REQ	RO	gpio wake up request	0x0
4	I2C_WAKEUP_REQ	RO	i2c wake up request	0x0
3	GPIO_INTR_MOD	RW	gpio interrupt/wake up mode 1: high enable 0:low enable	0x0
2	I2C_INTR_MOD	RW	i2c interrupt/wake up mode 1: i2c start enable 0: not used	0x0
1	STDBY_EN_LOSC	RW	standby state losc enable 0: disable 1: enable	0x1
0	STDBY_EN_LDO	RW	standby state ldo enable, 0: disable 1: enable	0x1

GO_STDBY_DLY2: Address(0x18)				
Bit	Symbol	R/W	Description	Default
7:0	GO_STDBY_DLY2_0	RW	The [23:16] bit of system go standby delay time counter threshold configuration register GO_STDBY_DLY; go standby delay time = GO_STDBY_DLY [23:0]/F _{sys} ;	0x03

GO_STDBY_DLY1: Address(0x19)				
Bit	Symbol	R/W	Description	Default
7:0	GO_STDBY_DLY1_0	RW	The [15:8] bit of system go standby delay time counter threshold configuration register GO_STDBY_DLY; go standby delay time = GO_STDBY_DLY [23:0]/F _{sys} ;	0xff

GO_STDBY_DLY0: Address(0x1A)				
Bit	Symbol	R/W	Description	Default

7:0	GO_STDBY_DLY0_0	RW	The [7:0] bit of system go standby delay time counter threshold configuration register GO_STDBY_DLY; go standby delay time = GO_STDBY_DLY [23:0]/F _{sys} ;	0xff
-----	-----------------	----	---	------

GO_STDBY_CFG: Address(0x1B)				
Bit	Symbol	R/W	Description	Default
7	CMD_STDBY_REQ	RW	Command to go standby. This bit writes 1 to make the system enter standby, and then the hardware automatically clears	0
6:4	Reserved	RO	Not used	0
3	WRCLR_WAKEUP_REQ	RW	i2c write to clear wake up request configuration register, auto clear when go standby 0: disable 1: enable	0x0
2	CLR_WAKEUP_MOD	RW	clear wake up request mode configuration 0: i2c write clear 1: auto clear	0x0
1:0	AFE_STDBY_MOD	RW	afe trigger to go standby mode configuration 01: afe_rd_done trigger(I2C matches the address of the last channel data register enabled) 10: afe_ad_intr trigger(The ADF bit is 1 and ADIE is enabled) 11: afe_rd_done or afe_ad_intr trigger 00: no trigger	0x0

AFE_TIMER2: Address(0x1C)				
Bit	Symbol	R/W	Description	Default
7:0	AFE_TIMER2_0	RW	The [23:16] bit of afe trigger time counter threshold register configuration AFE_TIMER; It is used to trigger AFE operation under system working state; afe trigger time = AFE_TIMER/F _{sys}	0x03

AFE_TIMER1: Address(0x1D)				
Bit	Symbol	R/W	Description	Default
7:0	AFE_TIMER1_0	RW	The [15:8] bit of afe trigger time counter threshold configuration register AFE_TIMER; It is used to trigger AFE operation under system working state;afe trigger time = AFE_TIMER/F _{sys}	0xff

AFE_TIMER0: Address(0x1E)				
Bit	Symbol	R/W	Description	Default
7:0	AFE_TIMER0_0	RW	The [7:0] bit of afe trigger time counter threshold configuration register AFE_TIMER; It is used to trigger AFE operation under system working state; afe trigger time = AFE_TIMER/F _{sys}	0xff

INTR_MASK: Address(0x1F)				
--------------------------	--	--	--	--

Bit	Symbol	R/W	Description	Default
7	BASE_INTR_MASK	RW	base interrupt mask, enable interrupt output to INTN pin 1: enable output 0: disable output	0x0
6	FORCE_POS_INTR_MASK	RW	force posedge interrupt mask, enable interrupt output to INTN pin 1: enable output 0: disable output	0x0
5	FORCE_NEG_INTR_MASK	RW	force negedge interrupt mask, enable interrupt output to INTN pin 1: enable output 0: disable output	0x0
4	WAKEUP_REQ_MASK	RW	wake up request interrupt mask, enable interrupt output to INTN pin 1: enable output 0: disable output	0x0
3	SWDT_INTR_MASK	RW	swdt interrupt mask, enable interrupt output to INTN pin 1: enable output 0: disable output	0x0
2	AFE_CMP1_INTR_MASK	RW	afe compare 1 interrupt mask, enable interrupt output to INTN pin 1: enable output 0: disable output	0x0
1	AFE_CMP0_INTR_MASK	RW	afe compare 0 interrupt mask, enable interrupt output to INTN pin 1: enable output 0: disable output	0x0
0	AFE_AD_INTR_MASK	RW	afe adc interrupt mask, enable interrupt output to INTN pin 1: enable output 0: disable output	0x1

INTR_STAT: Address(0x20)				
Bit	Symbol	R/W	Description	Default
7	BASE_INTR	RO	base line interrupt, write an arbitrary value to the FASR0 or FASR1 registers to clear this bit 1: valid 0: invalid	0x0
6	FORCE_POS_INTR	RO	force posedge interrupt, write an arbitrary value to the FASR0 or FASR1 registers to clear this bit 1: valid 0: invalid	0x0
5	FORCE_NEG_INTR	RO	foece negedge interrupt, write an arbitrary value to the FASR0 or FASR1 registers to clear this bit 1: valid 0: invalid	0x0
4	WAKEUP_REQ	RO	wake up request interrupt, when the bit of CLR_WAKEUP_MOD is 1 , auto clear after waking up , when the bit of CLR_WAKEUP_MOD is 0 , write 1 to WRCLR_WAKEUP_REQ to clear this bit	0x0

			1: valid 0: invalid	
3	SWDT_INTR	RO	swdt interrupt, when the bit of CLR_WAKEUP_MOD is 1 , auto clear after waking up , when the bit of CLR_WAKEUP_MOD is 0 , write 1 to WRCLR_WAKEUP_REQ to clear this bit 1: valid 0: invalid	0x0
2	AFE_CMP1_INTR	RO	afe compare 1 interrupt, write 1 to CMPF1 to clear this bit 1: valid 0: invalid	0x0
1	AFE_CMP0_INTR	RO	afe compare 0 interrupt, write 1 to CMPF0 to clear this bit 1: valid 0: invalid	0x0
0	AFE_AD_INTR	RO	afe adc interrupt, write 1 to ADF to clear this bit 1: valid 0: invalid	0x0

ANA_ADJ_CFG: Address(0x21)				
Bit	Symbol	R/W	Description	Default
7	Reserved	RO	Not used	0
6	INTR_LEVEL	RW	interrupt output level selection 1: high level 0: low level	0x0
5:4	VS_ADJ	RW	vs voltage adjustment 00: 2.4V 01: 2.8V 10: 3.0V 11: 3.1V	0x2
3	UVLO_HV_EN	RW	UVLO high voltage control 0: 3.93/4.04 1: 6.40/6.50	0x0
2:0	UVLO_ADJ	RW	uvlo adjustment 000: 1.78/1.87 001: 1.93/2.03 010: 2.30/2.43 011: 2.61/2.70 100: 3.01/3.13 101: 3.57/3.67 110: 3.93/4.04 111: 6.40/6.50 or 3.93/4.04	0x2

ANA_LDO_CUR: Address(0x22)				
Bit	Symbol	R/W	Description	Default
7:5	Reserved	RO	Not used	0
4	SEL_TEMP	RW	temperature sensor mode selection 0: double port VTEMP_P/VTEMP_N output 1: single port VTEMP output	0x0
3:1	Reserved	RO	Not used	0

0	PJ_VS	RW	vs mode selection 0: CVS discharge 1: CVS don't discharge	0x1
---	-------	----	---	-----

PAD_EN_OD: Address(0x25)				
Bit	Symbol	R/W	Description	Default
7:2	Reserved	RO	Not used	0
1	INTN_EN_OD	RW	PAD_INTN open drain enable, 0: disable 1: enable	0x1
0	VS0_EN_OD	RW	PAD_VS0 open drain enable 0: disable 1: enable	0x1

PD_PU_RES: Address(0x26)				
Bit	Symbol	R/W	Description	Default
7	Reserved	RO	Not used	0
6:4	PD_RES	RW	PAD_VS0 pull down resistance enable xx0: disable xx1: enable	0x0
3	Reserved	RO	Not used	0
2:0	PU_RES	RW	PAD_VS0 pull up resistance enable xx0: disable xx1: enable	0x0

PAD_ADJ: Address(0x27)				
Bit	Symbol	R/W	Description	Default
7	Reserved	RO	Not used	0
6	not use	RW	Not used	0x0
5	PA_SW_PD_0	RW	VS1 analog switch configuration 1: off 0: on	0x1
4	PA_SW_PD_1	RW	VS0 analog switch configuration 1: off 0: on	0x1
3	ADJ_OD_0	RW	SDA, open drain output delay control 0: 20ns 1: 2ns	0x0
2	ADJ_OD_1	RW	SCL open drain output delay control 0: 20ns 1: 2ns	0x0
1	ADJ_OD_2	RW	INTN open drain output delay control 0: 20ns 1: 2ns	0x0
0	not use	RW	Not used	0x0

SR_CTRL: Address(0x28)				
Bit	Symbol	R/W	Description	Default
7:6	Reserved	RO	Not used	0
5:4	not use	RW	Not used	0x2
3:2	Reserved	RO	Not used	0

1:0	SR_CTRL_VS0	RW	PAD_VS0 output delay control 00: 110ns 01: 21ns 10: 9ns 11: 3ns	0x2
-----	-------------	----	---	-----

FAST_CTRL: Address(0x29)				
Bit	Symbol	R/W	Description	Default
7	EN_GNR	RW	general call function enable, 0: disable 1: enable	0x0
6	EN_GNR_ACK	RW	general call Acknowledge enable, 0: disable 1: enable	0x0
5:4	GNR_ADDR	RW	general call address low 2 bits selection	0x0
3	FAST_0	RW	SDA input FAST mode enable 0: disable 1: enable,	0x0
2	FAST_1	RW	SCL input FAST mode enable 0: disable 1: enable,	0x0
1	FAST_2	RW	INTN input FAST mode enable 0: disable 1: enable,	0x0
0	FAST_3	RW	VS0 input FAST mode enable 0: disable 1: enable,	0x0

EN_SCHMITT: Address(0x2A)				
Bit	Symbol	R/W	Description	Default
7:4	Reserved	RO	Not used	0
3	EN_SCHMITT_0	RW	SDA input schmitt mode enable 0: disable 1: enable	0x1
2	EN_SCHMITT_1	RW	SCL input schmitt mode enable 0: disable 1: enable	0x1
1	EN_SCHMITT_2	RW	INTN input schmitt mode enable 0: disable 1: enable	0x1
0	EN_SCHMITT_3	RW	VS0 input schmitt mode enable 0: disable 1: enable	0x1

ANA_EN_CFG: Address(0x2B)				
Bit	Symbol	R/W	Description	Default
7:4	Reserved	RO	Not used	0
3	EN_BIAS	RW	analog bias module enable, 1: enable 0: disable	0x1

2	EN_VS	RW	vs voltage output enable, 1: enable 0: disable	0x0
1	EN_UVLO	RW	analog uvlo module enable, 1: enable 0: disable	0x1
0	EN_PDR	RW	analog PDR module enable, 1: enable 0: disable	0x1

UVLO_CFG: Address(0x2C)				
Bit	Symbol	R/W	Description	Default
7:4	Reserved	RO	Not used	0
3	Reserved	RO	Not used	0
2	UVLO_CLR	RW	UVLO clear flag state, write any data to clear UVLO history ,	0x0
1	UVLO_HIS	RO	UVLO history flag state,1 indicate that low supply voltage is detected in the past, read only	0x0
0	UVLO	RO	UVLO current flag state, 1 indicate that low supply voltage is detected now, read only	0x0

RST_CFG: Address(0x2F)				
Bit	Symbol	R/W	Description	Default
7:5	Reserved	RO	Not used	0
4	CHIP_RST	RW	chip rst configuration register, 1: enable 0: disable	0x0
3:1	Reserved	RO	Not used	0
0	SOFT_RST	RW	soft rst configuration resgister, 1: enable 0: disable	0x0

ADCH0CR0_0: Address(0x30)				
Bit	Symbol	R/W	Description	Default
7	Reserved	RO	Not used	0
6:4	PD_AINP_0	RW	CHx sensor positive input selection (configure channel0, 6 channels in total,the channel offset address is 0x10*channel) 0b000: sensor0 positive 0b001: sensor1 positive 0b010: sensor2 positive 0b011: sensor3 positive	0x0
3	Reserved	RO	Not used	0
2:0	PD_AINN_0	RW	CHx sensor negative input selection (configure channel0, 6 channels in total,the channel offset address is 0x10*channel) 0b000: sensor1 negative 0b001: sensor0 negative 0b010: sensor3 negative 0b011: sensor2 negative	0x0

ADCH0CR0_1: Address(0x31)				
Bit	Symbol	R/W	Description	Default
7	RED_OS_0	RW	offset Residual cancellation enable signal (configure channel0, 6 channels in total,the channel offset address is 0x10*channel) 0: no elimination of residuals 1: elimination of residuals	0x0
6	Reserved	RO	Not used	0
5	PD_DOUBLE_VIN_0	RW	in ADC single-ended mode, turn off the double-ended input (configure channel0, 6 channels in total,the channel offset address is 0x10*channel) 0: double-ended input 1: single-ended input	0x1
4	EN_DIFF_0	RW	ADC input working mode (configure channel0, 6 channels in total,the channel offset address is 0x10*channel) 0: single-ended mode 1: differential mode	0x1
3:2	Reserved	RO	Not used	0
1:0	PD_SW_IN_0	RW	VS1-VS0 analog switch control (configure channel0, 6 channels in total,the channel offset address is 0x10*channel) 0: strobe vs 1: disable	0x3

ADCH0CR0_2: Address(0x32)				
Bit	Symbol	R/W	Description	Default
7:5	Reserved	RO	Not used	0
4:0	SN_MUX_0	RW	negative terminal of DC voltage channel. (configure channel0, 6 channels in total,the channel offset address is 0x10*channel) 0b10000: sensor negative input channel 0b01000: vtemp 0b00100: vs 0b00010: gnd 0b00001: vtemp_n	0x10

ADCH0CR0_3: Address(0x33)				
Bit	Symbol	R/W	Description	Default
7:5	Reserved	RO	Not used	0
4:0	SP_MUX_0	RW	Positive terminal of DC voltage channel. (configure channel0, 6 channels in total,the channel offset address is 0x10*channel) 0b10000: sensor positive input channel 0b01000: vtemp 0b00100: vs 0b00010: gnd 0b00001: vtemp_p	0x10

ADCH0CR1_0: Address(0x34)				
Bit	Symbol	R/W	Description	Default

7	Reserved	RO	Not used	0
6:4	GAIN_PGA1_0	RW	First level of PGA gain selection (configure channel0, 6 channels in total,the channel offset address is 0x10*channel) 0b000: 1 0b001: 16 0b010: 32 0b011: 64 0b100: 128 0b101: 256, do not use when GAIN_PGA2 equals 8 0b110: 256, do not use when GAIN_PGA2 equals 8 0b111: 256, do not use when GAIN_PGA2 equals 8	0x2
3	Reserved	RO	Not used	0
2:0	GAIN_PGA2_0	RW	second level of PGA gain selection (configure channel0, 6 channels in total,the channel offset address is 0x10*channel) 0b000: 1 0b001: 2 0b010: 3 0b011: 4 0b100: 5 0b101: 6 0b110: 7 0b111: 8	0x3

ADCH0CR1_1: Address(0x35)				
Bit	Symbol	R/W	Description	Default
7:5	Reserved	RO	Not used	0
4	Reserved	RW	Not used	0
3	EN_PGA_0	RW	PGA enable switch (configure channel0, 6 channels in total,the channel offset address is 0x10*channel) 0: disable 1: enable	0x0
2	PD_PGA1_0	RW	First level of PGA enable switch (configure channel0, 6 channels in total,the channel offset address is 0x10*channel) 1: disable 0: enable	0x0
1	PD_PGA2_0	RW	second level of PGA enable switch (configure channel0, 6 channels in total,the channel offset address is 0x10*channel) 1: disable 0: enable	0x0
0	PD_FILTER_0	RW	turn off the PGA2 filter (configure channel0, 6 channels in total,the channel offset address is 0x10*channel) 1: turn off 0: turn on	0x0

ADCH0CR1_2: Address(0x36)				
Bit	Symbol	R/W	Description	Default
7:6	VREF_SEL_0	RW	VRP voltage selection (configure channel0, 6 channels in total,the channel offset address is 0x10*channel) 0b00: 2.4v 0b01: 2.8v 0b10: 3.0v 0b11: 3.1v	0x1
5	VREF_GEN_SEL_0	RW	ADC refrence voltage selection (configure channel0, 6 channels in total,the channel offset address is 0x10*channel) 0: AVDD 1: VRP	0x1
4	VCM_ADJ_0	RW	PGA output common mode voltage selection (configure channel0, 6 channels in total,the channel offset address is 0x10*channel) 0: 0.5xAVDD 1: 0.5xAVDD-0.1	0x0
3	Reserved	RO	Not used	0
2:0	ADC_IBIAS_0	RW	ADC BIAS current control (configure channel0, 6 channels in total,the channel offset address is 0x10*channel) 0b000: 2μA 0b001: 2.5μA 0b010: 3μA 0b011: 3.5μA 0b100: 4μA 0b101: 4.5μA 0b110: 5μA 0b111: 5.5μA	0x4

ADCH0CR1_3: Address(0x37)				
Bit	Symbol	R/W	Description	Default
7	Reserved	RO	Not used	0
6:4	PGA_IBIASE_0	RW	PGA module overall current selection (configure channel0, 6 channels in total,the channel offset address is 0x10*channel) 0b000: 1μA 0b001: 1.25μA 0b010: 1.5μA 0b011: 1.75μA 0b100: 2μA 0b101: 2.25μA 0b110: 2.5μA 0b111: 2.75μA	0x4
3:2	Reserved	RO	Not used	0
1:0	BW_FILTER_0	RW	PGA RC filter output frequency selection (configure channel0, 6 channels in total,the channel offset address is 0x10*channel) 0b00:50kHz 0b01:62.5kHz 0b10:125kHz 0b11:250kHz	0x3

DACH0CR_0: Address(0x38)				
Bit	Symbol	R/W	Description	Default
7:1	Reserved	RO	Not used	0
0	VDAC_RANGE_0	RW	DAC calibration offset range (configure channel0, 6 channels in total,the channel offset address is 0x10*channel) 0: 0.614xVS/3 1: 0.614x(2xVS/9)	0x0

DACH0CR_1: Address(0x39)				
Bit	Symbol	R/W	Description	Default
7:6	Reserved	RO	Not used	0
5	EN_DAC_CAL_0	RW	enable digital DAC calibration loop operation (configure channel0, 6 channels in total,the channel offset address is 0x10*channel) 0: disable 1: enable	0x0
4	EN_DAC_0	RW	enable calibration offset DAC (configure channel0, 6 channels in total,the channel offset address is 0x10*channel) 0: disable 1: enable	0x0
3	EN_DAC_VIN_0	RW	turn on DAC negative current input (configure channel0, 6 channels in total,the channel offset address is 0x10*channel) 0: turn off 1: turn on	0x1
2	DIR_DAC_0	RW	DAC direction select (configure channel0, 6 channels in total,the channel offset address is 0x10*channel) 0: disable current direction 1: enable current direction	0x0
1	DIR_MODE0_0	RW	DAC direction select (configure channel0, 6 channels in total,the channel offset address is 0x10*channel) 0: disable affect offset 1: enable affect offset	0x0
0	DIR_MODE1_0	RW	DAC direction select (configure channel0, 6 channels in total,the channel offset address is 0x10*channel) 0: disable affect offset 1: enable affect offset	0x1

DACH0CR_2: Address(0x3A)				
Bit	Symbol	R/W	Description	Default
7:0	Reserved	RO	Not used	0

DACH0CR_3: Address(0x3B)				
Bit	Symbol	R/W	Description	Default
7:0	Reserved	RO	Not used	0

DACH0DR_0: Address(0x3C)				
Bit	Symbol	R/W	Description	Default

7:0	DA_L_0	RW	D/A data register[7:0] (configure channel0, 6 channels in total,the channel offset address is 0x10*channel)	0x0
-----	--------	----	---	-----

DACH0DR_1: Address(0x3D)				
Bit	Symbol	R/W	Description	Default
7:3	Reserved	RO	Not used	0
2:0	DA_H_0	RW	D/A data register[10:8] (configure channel0, 6 channels in total,the channel offset address is 0x10*channel)	0x0

DACH0DR_2: Address(0x3E)				
Bit	Symbol	R/W	Description	Default
7:0	AD_OS_L_0	RW	ADC OFFSET residual.directly save the Adc result[7:0],that is, the ADC code, and convert it to two's complement operation when used (configure channel0, 6 channels in total,the channel offset address is 0x10*channel)	0x0

DACH0DR_3: Address(0x3F)				
Bit	Symbol	R/W	Description	Default
7:6	Reserved	RO	Not used	0
5:0	AD_OS_H_0	RW	ADC OFFSET residual.directly save the Adc result[13:8],that is, the ADC code, and convert it to two's complement operation when used (configure channel0, 6 channels in total,the channel offset address is 0x10*channel)	0x0

ADCH1CR0_0: Address(0x40)				
Bit	Symbol	R/W	Description	Default
7	Reserved	RO	Not used	0
6:4	PD_AINP_1	RW	CHx sensor positive input selection (configure channel1, 6 channels in total,the channel offset address is 0x10*channel) 0b000: sensor0 positive 0b001: sensor1 positive 0b010: sensor2 positive 0b011: sensor3 positive	0x0
3	Reserved	RO	Not used	0
2:0	PD_AINN_1	RW	CHx sensor negative input selection (configure channel1, 6 channels in total,the channel offset address is 0x10*channel) 0b000: sensor1 negative 0b001: sensor0 negative 0b010: sensor3 negative 0b011: sensor2 negative	0x0

ADCH1CR0_1: Address(0x41)				
Bit	Symbol	R/W	Description	Default

7	RED_OS_1	RW	offset Residual cancellation enable signal (configure channel1, 6 channels in total,the channel offset address is 0x10*channel) 0: no elimination of residuals 1: elimination of residuals	0x0
6	Reserved	RO	Not used	0
5	PD_DOUBLE_VIN_1	RW	in ADC single-ended mode, turn off the double-ended input (configure channel1, 6 channels in total,the channel offset address is 0x10*channel) 0: double-ended input 1: single-ended input	0x1
4	EN_DIFF_1	RW	ADC input working mode (configure channel1, 6 channels in total,the channel offset address is 0x10*channel) 0: single-ended mode 1: differential mode	0x1
3:2	Reserved	RO	Not used	0
1:0	PD_SW_IN_1	RW	VS1-VS0 analog switch control (configure channel1, 6 channels in total,the channel offset address is 0x10*channel) 0: strobe vs 1: disable	0x3

ADCH1CR0_2: Address(0x42)				
Bit	Symbol	R/W	Description	Default
7:5	Reserved	RO	Not used	0
4:0	SN_MUX_1	RW	negative terminal of DC voltage channel. (configure channel1, 6 channels in total,the channel offset address is 0x10*channel) 0b10000: sensor negative input channel 0b01000: vtemp 0b00100: vs 0b00010: gnd 0b00001: vtemp_n	0x10

ADCH1CR0_3: Address(0x43)				
Bit	Symbol	R/W	Description	Default
7:5	Reserved	RO	Not used	0
4:0	SP_MUX_1	RW	Positive terminal of DC voltage channel. (configure channel1, 6 channels in total,the channel offset address is 0x10*channel) 0b10000: sensor positive input channel 0b01000: vtemp 0b00100: vs 0b00010: gnd 0b00001: vtemp_p	0x10

ADCH1CR1_0: Address(0x44)				
Bit	Symbol	R/W	Description	Default
7	Reserved	RO	Not used	0

6:4	GAIN_PGA1_1	RW	First level of PGA gain selection (configure channel1, 6 channels in total,the channel offset address is 0x10*channel) 0b000: 1 0b001: 16 0b010: 32 0b011: 64 0b100: 128 0b101: 256, do not use when GAIN_PGA2 equals 8 0b110: 256, do not use when GAIN_PGA2 equals 8 0b111: 256, do not use when GAIN_PGA2 equals 8	0x2
3	Reserved	RO	Not used	0
2:0	GAIN_PGA2_1	RW	second level of PGA gain selection (configure channel1, 6 channels in total,the channel offset address is 0x10*channel) 0b000: 1 0b001: 2 0b010: 3 0b011: 4 0b100: 5 0b101: 6 0b110: 7 0b111: 8	0x3

ADCH1CR1_1: Address(0x45)				
Bit	Symbol	R/W	Description	Default
7:5	Reserved	RO	Not used	0
4	Reserved	RW	Not used	0
3	EN_PGA_1	RW	PGA enable switch (configure channel1, 6 channels in total,the channel offset address is 0x10*channel) 0: disable 1: enable	0x0
2	PD_PGA1_1	RW	First level of PGA enable switch (configure channel1, 6 channels in total,the channel offset address is 0x10*channel) 1: disable 0: enable	0x0
1	PD_PGA2_1	RW	second level of PGA enable switch (configure channel1, 6 channels in total,the channel offset address is 0x10*channel) 1: disable 0: enable	0x0
0	PD_FILTER_1	RW	turn off the PGA2 filter (configure channel1, 6 channels in total,the channel offset address is 0x10*channel) 1: turn off 0: turn on	0x0

ADCH1CR1_2: Address(0x46)				
---------------------------	--	--	--	--

Bit	Symbol	R/W	Description	Default
7:6	VREF_SEL_1	RW	VRP voltage selection (configure channel1, 6 channels in total,the channel offset address is 0x10*channel) 0b00: 2.4v 0b01: 2.8v 0b10: 3.0v 0b11: 3.1v	0x1
5	VREF_GEN_SEL_1	RW	ADC refrence voltage selection (configure channel1, 6 channels in total,the channel offset address is 0x10*channel) 0: AVDD 1: VRP	0x1
4	VCM_ADJ_1	RW	PGA output common mode voltage selection (configure channel1, 6 channels in total,the channel offset address is 0x10*channel) 0: 0.5xAVDD 1: 0.5xAVDD-0.1	0x0
3	Reserved	RO	Not used	0
2:0	ADC_IBIAS_1	RW	ADC BIAS current control (configure channel1, 6 channels in total,the channel offset address is 0x10*channel) 0b000: 2μA 0b001: 2.5μA 0b010: 3μA 0b011: 3.5μA 0b100: 4μA 0b101: 4.5μA 0b110: 5μA 0b111: 5.5μA	0x4

ADCH1CR1_3: Address(0x47)				
Bit	Symbol	R/W	Description	Default
7	Reserved	RO	Not used	0
6:4	PGA_IBIASE_1	RW	PGA module overall current selection (configure channel1, 6 channels in total,the channel offset address is 0x10*channel) 0b000: 1μA 0b001: 1.25μA 0b010: 1.5μA 0b011: 1.75μA 0b100: 2μA 0b101: 2.25μA 0b110: 2.5μA 0b111: 2.75μA	0x4
3:2	Reserved	RO	Not used	0
1:0	BW_FILTER_1	RW	PGA RC filter output frequency selection (configure channel1, 6 channels in total,the channel offset address is 0x10*channel) 0b00:50kHz 0b01:62.5kHz 0b10:125kHz 0b11:250kHz	0x3

DACH1CR_0: Address(0x48)				
Bit	Symbol	R/W	Description	Default
7:1	Reserved	RO	Not used	0
0	VDAC_RANGE_1	RW	DAC calibration offset range (configure channel1, 6 channels in total,the channel offset address is 0x10*channel) 0: 0.614xVS/3 1: 0.614x(2xVS/9)	0x0

DACH1CR_1: Address(0x49)				
Bit	Symbol	R/W	Description	Default
7:6	Reserved	RO	Not used	0
5	EN_DAC_CAL_1	RW	enable digital DAC calibration loop operation (configure channel1, 6 channels in total,the channel offset address is 0x10*channel) 0: disable 1: enable	0x0
4	EN_DAC_1	RW	enable calibration offset DAC (configure channel1, 6 channels in total,the channel offset address is 0x10*channel) 0: disable 1: enable	0x0
3	EN_DAC_VIN_1	RW	turn on DAC negative current input (configure channel1, 6 channels in total,the channel offset address is 0x10*channel) 0: turn off 1: turn on	0x1
2	DIR_DAC_1	RW	DAC direction select (configure channel1, 6 channels in total,the channel offset address is 0x10*channel) 0: disable current direction 1: enable current direction	0x0
1	DIR_MODE0_1	RW	DAC direction select (configure channel1, 6 channels in total,the channel offset address is 0x10*channel) 0: disable affect offset 1: enable affect offset	0x0
0	DIR_MODE1_1	RW	DAC direction select (configure channel1, 6 channels in total,the channel offset address is 0x10*channel) 0: disable affect offset 1: enable affect offset	0x1

DACH1CR_2: Address(0x4A)				
Bit	Symbol	R/W	Description	Default
7:0	Reserved	RO	Not used	0

DACH1CR_3: Address(0x4B)				
Bit	Symbol	R/W	Description	Default
7:0	Reserved	RO	Not used	0

DACH1DR_0: Address(0x4C)				
Bit	Symbol	R/W	Description	Default

7:0	DA_L_1	RW	D/A data register[7:0] (configure channel1, 6 channels in total,the channel offset address is 0x10*channel)	0x0
-----	--------	----	---	-----

DACH1DR_1: Address(0x4D)				
Bit	Symbol	R/W	Description	Default
7:3	Reserved	RO	Not used	0
2:0	DA_H_1	RW	D/A data register[10:8] (configure channel1, 6 channels in total,the channel offset address is 0x10*channel)	0x0

DACH1DR_2: Address(0x4E)				
Bit	Symbol	R/W	Description	Default
7:0	AD_OS_L_1	RW	ADC OFFSET residual.directly save the Adc result[7:0],that is, the ADC code, and convert it to two's complement operation when used (configure channel1, 6 channels in total,the channel offset address is 0x10*channel)	0x0

DACH1DR_3: Address(0x4F)				
Bit	Symbol	R/W	Description	Default
7:6	Reserved	RO	Not used	0
5:0	AD_OS_H_1	RW	ADC OFFSET residual.directly save the Adc result[13:8],that is, the ADC code, and convert it to two's complement operation when used (configure channel1, 6 channels in total,the channel offset address is 0x10*channel)	0x0

ADCH2CR0_0: Address(0x50)				
Bit	Symbol	R/W	Description	Default
7	Reserved	RO	Not used	0
6:4	PD_AINP_2	RW	CHx sensor positive input selection (configure channel2, 6 channels in total,the channel offset address is 0x10*channel) 0b000: sensor0 positive 0b001: sensor1 positive 0b010: sensor2 positive 0b011: sensor3 positive	0x0
3	Reserved	RO	Not used	0
2:0	PD_AINN_2	RW	CHx sensor negative input selection (configure channel2, 6 channels in total,the channel offset address is 0x10*channel) 0b000: sensor1 negative 0b001: sensor0 negative 0b010: sensor3 negative 0b011: sensor2 negative	0x0

ADCH2CR0_1: Address(0x51)				
Bit	Symbol	R/W	Description	Default

7	RED_OS_2	RW	offset Residual cancellation enable signal (configure channel2, 6 channels in total,the channel offset address is 0x10*channel) 0: no elimination of residuals 1: elimination of residuals	0x0
6	Reserved	RO	Not used	0
5	PD_DOUBLE_VIN_2	RW	in ADC single-ended mode, turn off the double-ended input (configure channel2, 6 channels in total,the channel offset address is 0x10*channel) 0: double-ended input 1: single-ended input	0x1
4	EN_DIFF_2	RW	ADC input working mode (configure channel2, 6 channels in total,the channel offset address is 0x10*channel) 0: single-ended mode 1: differential mode	0x1
3:2	Reserved	RO	Not used	0
1:0	PD_SW_IN_2	RW	VS1-VS0 analog switch control (configure channel2, 6 channels in total,the channel offset address is 0x10*channel) 0: strobe vs 1: disable	0x3

ADCH2CR0_2: Address(0x52)				
Bit	Symbol	R/W	Description	Default
7:5	Reserved	RO	Not used	0
4:0	SN_MUX_2	RW	negative terminal of DC voltage channel. (configure channel2, 6 channels in total,the channel offset address is 0x10*channel) 0b10000: sensor negative input channel 0b01000: vtemp 0b00100: vs 0b00010: gnd 0b00001: vtemp_n	0x10

ADCH2CR0_3: Address(0x53)				
Bit	Symbol	R/W	Description	Default
7:5	Reserved	RO	Not used	0
4:0	SP_MUX_2	RW	Positive terminal of DC voltage channel. (configure channel2, 6 channels in total,the channel offset address is 0x10*channel) 0b10000: sensor positive input channel 0b01000: vtemp 0b00100: vs 0b00010: gnd 0b00001: vtemp_p	0x10

ADCH2CR1_0: Address(0x54)				
Bit	Symbol	R/W	Description	Default
7	Reserved	RO	Not used	0

6:4	GAIN_PGA1_2	RW	First level of PGA gain selection (configure channel2, 6 channels in total,the channel offset address is 0x10*channel) 0b000: 1 0b001: 16 0b010: 32 0b011: 64 0b100: 128 0b101: 256, do not use when GAIN_PGA2 equals 8 0b110: 256, do not use when GAIN_PGA2 equals 8 0b111: 256, do not use when GAIN_PGA2 equals 8	0x2
3	Reserved	RO	Not used	0
2:0	GAIN_PGA2_2	RW	second level of PGA gain selection(configure channel2, 6 channels in total,the channel offset address is 0x10*channel) 0b000: 1 0b001: 2 0b010: 3 0b011: 4 0b100: 5 0b101: 6 0b110: 7 0b111: 8	0x3

ADCH2CR1_1: Address(0x55)				
Bit	Symbol	R/W	Description	Default
7:5	Reserved	RO	Not used	0
4	Reserved	RW	Not used	0
3	EN_PGA_2	RW	PGA enable switch (configure channel2, 6 channels in total,the channel offset address is 0x10*channel) 0: disable 1: enable	0x0
2	PD_PGA1_2	RW	First level of PGA enable switch (configure channel2, 6 channels in total,the channel offset address is 0x10*channel) 1: disable 0: enable	0x0
1	PD_PGA2_2	RW	second level of PGA enable switch (configure channel2, 6 channels in total,the channel offset address is 0x10*channel) 1: disable 0: enable	0x0
0	PD_FILTER_2	RW	turn off the PGA2 filter (configure channel2, 6 channels in total,the channel offset address is 0x10*channel) 1: turn off 0: turn on	0x0

ADCH2CR1_2: Address(0x56)				
---------------------------	--	--	--	--

Bit	Symbol	R/W	Description	Default
7:6	VREF_SEL_2	RW	VRP voltage selection(configure channel2, 6 channels in total,the channel offset address is 0x10*channel) 0b00: 2.4v 0b01: 2.8v 0b10: 3.0v 0b11: 3.1v	0x1
5	VREF_GEN_SEL_2	RW	ADC refrence voltage selection(configure channel2, 6 channels in total,the channel offset address is 0x10*channel) 0: AVDD 1: VRP	0x1
4	VCM_ADJ_2	RW	PGA output common mode voltage selection(configure channel2, 6 channels in total,the channel offset address is 0x10*channel) 0: 0.5xAVDD 1: 0.5xAVDD-0.1	0x0
3	Reserved	RO	Not used	0
2:0	ADC_IBIAS_2	RW	ADC BIAS current control(configure channel2, 6 channels in total,the channel offset address is 0x10*channel) 0b000: 2μA 0b001: 2.5μA 0b010: 3μA 0b011: 3.5μA 0b100: 4μA 0b101: 4.5μA 0b110: 5μA 0b111: 5.5μA	0x4

ADCH2CR1_3: Address(0x57)				
Bit	Symbol	R/W	Description	Default
7	Reserved	RO	Not used	0
6:4	PGA_IBIASE_2	RW	PGA module overall current selection(configure channel2, 6 channels in total,the channel offset address is 0x10*channel) 0b000: 1uA 0b001: 1.25μA 0b010: 1.5μA 0b011: 1.75μA 0b100: 2μA 0b101: 2.25μA 0b110: 2.5μA 0b111: 2.75μA	0x4
3:2	Reserved	RO	Not used	0
1:0	BW_FILTER_2	RW	PGA RC filter output frequency selection(configure channel2, 6 channels in total,the channel offset address is 0x10*channel) 0b00:50kHz 0b01:62.5kHz 0b10:125kHz 0b11:250kHz	0x3

DACH2CR_0: Address(0x58)				
Bit	Symbol	R/W	Description	Default
7:1	Reserved	RO	Not used	0
0	VDAC_RANGE_2	RW	DAC calibration offset range (configure channel2, 6 channels in total,the channel offset address is 0x10*channel) 0: 0.614xVS/3 1: 0.614x(2xVS/9)	0x0

DACH2CR_1: Address(0x59)				
Bit	Symbol	R/W	Description	Default
7:6	Reserved	RO	Not used	0
5	EN_DAC_CAL_2	RW	enable digital DAC calibration loop operation(configure channel2, 6 channels in total,the channel offset address is 0x10*channel) 0: disable 1: enable	0x0
4	EN_DAC_2	RW	enable calibration offset DAC (configure channel2, 6 channels in total,the channel offset address is 0x10*channel) 0: disable 1: enable	0x0
3	EN_DAC_VIN_2	RW	turn on DAC negative current input(configure channel2, 6 channels in total,the channel offset address is 0x10*channel) 0: turn off 1: turn on	0x1
2	DIR_DAC_2	RW	DAC direction select (configure channel2, 6 channels in total,the channel offset address is 0x10*channel) 0: disable current direction 1: enable current direction	0x0
1	DIR_MODE0_2	RW	DAC direction select (configure channel2, 6 channels in total,the channel offset address is 0x10*channel) 0: disable affect offset 1: enable affect offset	0x0
0	DIR_MODE1_2	RW	DAC direction select (configure channel2, 6 channels in total,the channel offset address is 0x10*channel) 0: disable affect offset 1: enable affect offset	0x1

DACH2CR_2: Address(0x5A)				
Bit	Symbol	R/W	Description	Default
7:0	Reserved	RO	Not used	0

DACH2CR_3: Address(0x5B)				
Bit	Symbol	R/W	Description	Default
7:0	Reserved	RO	Not used	0

DACH2DR_0: Address(0x5C)				
Bit	Symbol	R/W	Description	Default

7:0	DA_L_2	RW	D/A data register[7:0] (configure channel2, 6 channels in total,the channel offset address is 0x10*channel)	0x0
-----	--------	----	---	-----

DACH2DR_1: Address(0x5D)				
Bit	Symbol	R/W	Description	Default
7:3	Reserved	RO	Not used	0
2:0	DA_H_2	RW	D/A data register[10:8] (configure channel2, 6 channels in total,the channel offset address is 0x10*channel)	0x0

DACH2DR_2: Address(0x5E)				
Bit	Symbol	R/W	Description	Default
7:0	AD_OS_L_2	RW	ADC OFFSET residual.directly save the Adc result[7:0],that is, the ADC code, and convert it to two's complement operation when used (configure channel2, 6 channels in total,the channel offset address is 0x10*channel)	0x0

DACH2DR_3: Address(0x5F)				
Bit	Symbol	R/W	Description	Default
7:6	Reserved	RO	Not used	0
5:0	AD_OS_H_2	RW	ADC OFFSET residual.directly save the Adc result[13:8],that is, the ADC code, and convert it to two's complement operation when used (configure channel2, 6 channels in total,the channel offset address is 0x10*channel)	0x0

ADCH3CR0_0: Address(0x60)				
Bit	Symbol	R/W	Description	Default
7	Reserved	RO	Not used	0
6:4	PD_AINP_3	RW	CHx sensor positive input selection (configure channel3, 6 channels in total,the channel offset address is 0x10*channel) 0b000: sensor0 positive 0b001: sensor1 positive 0b010: sensor2 positive 0b011: sensor3 positive	0x0
3	Reserved	RO	Not used	0
2:0	PD_AINN_3	RW	CHx sensor negative input selection (configure channel3, 6 channels in total,the channel offset address is 0x10*channel) 0b000: sensor1 negative 0b001: sensor0 negative 0b010: sensor3 negative 0b011: sensor2 negative	0x0

ADCH3CR0_1: Address(0x61)				
Bit	Symbol	R/W	Description	Default

7	RED_OS_3	RW	offset Residual cancellation enable signal (configure channel3, 6 channels in total,the channel offset address is 0x10*channel) 0: no elimination of residuals 1: elimination of residuals	0x0
6	Reserved	RO	Not used	0
5	PD_DOUBLE_VIN_3	RW	in ADC single-ended mode, turn off the double-ended input (configure channel3, 6 channels in total,the channel offset address is 0x10*channel) 0: double-ended input 1: single-ended input	0x1
4	EN_DIFF_3	RW	ADC input working mode (configure channel3, 6 channels in total,the channel offset address is 0x10*channel) 0: single-ended mode 1: differential mode	0x1
3:2	Reserved	RO	Not used	0
1:0	PD_SW_IN_3	RW	VS1-VS0 analog switch control (configure channel3, 6 channels in total,the channel offset address is 0x10*channel) 0: strobe vs 1: disable	0x3

ADCH3CR0_2: Address(0x62)				
Bit	Symbol	R/W	Description	Default
7:5	Reserved	RO	Not used	0
4:0	SN_MUX_3	RW	negative terminal of DC voltage channel. (configure channel3, 6 channels in total,the channel offset address is 0x10*channel) 0b10000: sensor negative input channel 0b01000: vtemp 0b00100: vs 0b00010: gnd 0b00001: vtemp_n	0x10

ADCH3CR0_3: Address(0x63)				
Bit	Symbol	R/W	Description	Default
7:5	Reserved	RO	Not used	0
4:0	SP_MUX_3	RW	Positive terminal of DC voltage channel. (configure channel3, 6 channels in total,the channel offset address is 0x10*channel) 0b10000: sensor positive input channel 0b01000: vtemp 0b00100: vs 0b00010: gnd 0b00001: vtemp_p	0x10

ADCH3CR1_0: Address(0x64)				
Bit	Symbol	R/W	Description	Default
7	Reserved	RO	Not used	0

6:4	GAIN_PGA1_3	RW	First level of PGA gain selection (configure channel3, 6 channels in total,the channel offset address is 0x10*channel) 0b000: 1 0b001: 16 0b010: 32 0b011: 64 0b100: 128 0b101: 256, do not use when GAIN_PGA2 equals 8 0b110: 256, do not use when GAIN_PGA2 equals 8 0b111: 256, do not use when GAIN_PGA2 equals 8	0x2
3	Reserved	RO	Not used	0
2:0	GAIN_PGA2_3	RW	second level of PGA gain selection (configure channel3, 6 channels in total,the channel offset address is 0x10*channel) 0b000: 1 0b001: 2 0b010: 3 0b011: 4 0b100: 5 0b101: 6 0b110: 7 0b111: 8	0x3

ADCH3CR1_1: Address(0x65)				
Bit	Symbol	R/W	Description	Default
7:5	Reserved	RO	Not used	0
4	Reserved	RW	Not used	0
3	EN_PGA_3	RW	PGA enable switch (configure channel3, 6 channels in total,the channel offset address is 0x10*channel) 0: disable 1: enable	0x0
2	PD_PGA1_3	RW	First level of PGA enable switch (configure channel3, 6 channels in total,the channel offset address is 0x10*channel) 1: disable 0: enable	0x0
1	PD_PGA2_3	RW	second level of PGA enable switch (configure channel3, 6 channels in total,the channel offset address is 0x10*channel) 1: disable 0: enable	0x0
0	PD_FILTER_3	RW	turn off the PGA2 filter (configure channel3, 6 channels in total,the channel offset address is 0x10*channel) 1: turn off 0: turn on	0x0

ADCH3CR1_2: Address(0x66)				
---------------------------	--	--	--	--

Bit	Symbol	R/W	Description	Default
7:6	VREF_SEL_3	RW	VRP voltage selection (configure channel3, 6 channels in total,the channel offset address is 0x10*channel) 0b00: 2.4v 0b01: 2.8v 0b10: 3.0v 0b11: 3.1v	0x1
5	VREF_GEN_SEL_3	RW	ADC refrence voltage selection (configure channel3, 6 channels in total,the channel offset address is 0x10*channel) 0: AVDD 1: VRP	0x1
4	VCM_ADJ_3	RW	PGA output common mode voltage selection (configure channel3, 6 channels in total,the channel offset address is 0x10*channel) 0: 0.5xAVDD 1: 0.5xAVDD-0.1	0x0
3	Reserved	RO	Not used	0
2:0	ADC_IBIAS_3	RW	ADC BIAS current control (configure channel3, 6 channels in total,the channel offset address is 0x10*channel) 0b000: 2μA 0b001: 2.5μA 0b010: 3μA 0b011: 3.5μA 0b100: 4μA 0b101: 4.5μA 0b110: 5μA 0b111: 5.5μA	0x4

ADCH3CR1_3: Address(0x67)				
Bit	Symbol	R/W	Description	Default
7	Reserved	RO	Not used	0
6:4	PGA_IBIASE_3	RW	PGA module overall current selection (configure channel3, 6 channels in total,the channel offset address is 0x10*channel) 0b000: 1μA 0b001: 1.25μA 0b010: 1.5μA 0b011: 1.75μA 0b100: 2μA 0b101: 2.25μA 0b110: 2.5μA 0b111: 2.75μA	0x4
3:2	Reserved	RO	Not used	0
1:0	BW_FILTER_3	RW	PGA RC filter output frequency selection (configure channel3, 6 channels in total,the channel offset address is 0x10*channel) 0b00:50kHz 0b01:62.5kHz 0b10:125kHz 0b11:250kHz	0x3

DACH3CR_0: Address(0x68)				
Bit	Symbol	R/W	Description	Default
7:1	Reserved	RO	Not used	0
0	VDAC_RANGE_3	RW	DAC calibration offset range (configure channel3, 6 channels in total,the channel offset address is 0x10*channel) 0: 0.614xVS/3 1: 0.614x (2xVS/9)	0x0

DACH3CR_1: Address(0x69)				
Bit	Symbol	R/W	Description	Default
7:6	Reserved	RO	Not used	0
5	EN_DAC_CAL_3	RW	enable digital DAC calibration loop operation (configure channel3, 6 channels in total,the channel offset address is 0x10*channel) 0: disable 1: enable	0x0
4	EN_DAC_3	RW	enable calibration offset DAC (configure channel3, 6 channels in total,the channel offset address is 0x10*channel) 0: disable 1: enable	0x0
3	EN_DAC_VIN_3	RW	turn on DAC negative current input (configure channel3, 6 channels in total,the channel offset address is 0x10*channel) 0: turn off 1: turn on	0x1
2	DIR_DAC_3	RW	DAC direction select (configure channel3, 6 channels in total,the channel offset address is 0x10*channel) 0: disable current direction 1: enable current direction	0x0
1	DIR_MODE0_3	RW	DAC direction select (configure channel3, 6 channels in total,the channel offset address is 0x10*channel) 0: disable affect offset 1: enable affect offset	0x0
0	DIR_MODE1_3	RW	DAC direction select (configure channel3, 6 channels in total,the channel offset address is 0x10*channel) 0: disable affect offset 1: enable affect offset	0x1

DACH3CR_2: Address(0x6A)				
Bit	Symbol	R/W	Description	Default
7:0	Reserved	RO	Not used	0

DACH3CR_3: Address(0x6B)				
Bit	Symbol	R/W	Description	Default
7:0	Reserved	RO	Not used	0

DACH3DR_0: Address(0x6C)				
Bit	Symbol	R/W	Description	Default

7:0	DA_L_3	RW	D/A data register[7:0] (configure channel3, 6 channels in total,the channel offset address is 0x10*channel)	0x0
-----	--------	----	---	-----

DACH3DR_1: Address(0x6D)				
Bit	Symbol	R/W	Description	Default
7:3	Reserved	RO	Not used	0
2:0	DA_H_3	RW	D/A data register[10:8] (configure channel3, 6 channels in total,the channel offset address is 0x10*channel)	0x0

DACH3DR_2: Address(0x6E)				
Bit	Symbol	R/W	Description	Default
7:0	AD_OS_L_3	RW	ADC OFFSET residual.directly save the Adc result[7:0],that is, the ADC code, and convert it to two's complement operation when used (configure channel3, 6 channels in total,the channel offset address is 0x10*channel)	0x0

DACH3DR_3: Address(0x6F)				
Bit	Symbol	R/W	Description	Default
7:6	Reserved	RO	Not used	0
5:0	AD_OS_H_3	RW	ADC OFFSET residual.directly save the Adc result[13:8],that is, the ADC code, and convert it to two's complement operation when used (configure channel3, 6 channels in total,the channel offset address is 0x10*channel)	0x0

ADCH4CR0_0: Address(0x70)				
Bit	Symbol	R/W	Description	Default
7	Reserved	RO	Not used	0
6:4	PD_AINP_4	RW	CHx sensor positive input selection (configure channel4, 6 channels in total,the channel offset address is 0x10*channel) 0b000: sensor0 positive 0b001: sensor1 positive 0b010: sensor2 positive 0b011: sensor3 positive	0x0
3	Reserved	RO	Not used	0
2:0	PD_AINN_4	RW	CHx sensor negative input selection (configure channel4, 6 channels in total,the channel offset address is 0x10*channel) 0b000: sensor1 negative 0b001: sensor0 negative 0b010: sensor3 negative 0b011: sensor2 negative	0x0

ADCH4CR0_1: Address(0x71)				
Bit	Symbol	R/W	Description	Default

7	RED_OS_4	RW	offset Residual cancellation enable signal (configure channel4, 6 channels in total,the channel offset address is 0x10*channel) 0: no elimination of residuals 1: elimination of residuals	0x0
6	Reserved	RO	Not used	0
5	PD_DOUBLE_VIN_4	RW	in ADC single-ended mode, turn off the double-ended input (configure channel4, 6 channels in total,the channel offset address is 0x10*channel) 0: double-ended input 1: single-ended input	0x1
4	EN_DIFF_4	RW	ADC input working mode (configure channel4, 6 channels in total,the channel offset address is 0x10*channel) 0: single-ended mode 1: differential mode	0x1
3:2	Reserved	RO	Not used	0
1:0	PD_SW_IN_4	RW	VS1-VS0 analog switch control (configure channel4, 6 channels in total,the channel offset address is 0x10*channel) 0: strobe vs 1: disable	0x3

ADCH4CR0_2: Address(0x72)				
Bit	Symbol	R/W	Description	Default
7:5	Reserved	RO	Not used	0
4:0	SN_MUX_4	RW	negative terminal of DC voltage channel. (configure channel4, 6 channels in total,the channel offset address is 0x10*channel) 0b10000: sensor negative input channel 0b01000: vtemp 0b00100: vs 0b00010: gnd 0b00001: vtemp_n	0x10

ADCH4CR0_3: Address(0x73)				
Bit	Symbol	R/W	Description	Default
7:5	Reserved	RO	Not used	0
4:0	SP_MUX_4	RW	Positive terminal of DC voltage channel. (configure channel4, 6 channels in total,the channel offset address is 0x10*channel) 0b10000: sensor positive input channel 0b01000: vtemp 0b00100: vs 0b00010: gnd 0b00001: vtemp_p	0x10

ADCH4CR1_0: Address(0x74)				
Bit	Symbol	R/W	Description	Default
7	Reserved	RO	Not used	0

6:4	GAIN_PGA1_4	RW	First level of PGA gain selection (configure channel4, 6 channels in total,the channel offset address is 0x10*channel) 0b000: 1 0b001: 16 0b010: 32 0b011: 64 0b100: 128 0b101: 256, do not use when GAIN_PGA2 equals 8 0b110: 256, do not use when GAIN_PGA2 equals 8 0b111: 256, do not use when GAIN_PGA2 equals 8	0x2
3	Reserved	RO	Not used	0
2:0	GAIN_PGA2_4	RW	second level of PGA gain selection (configure channel4, 6 channels in total,the channel offset address is 0x10*channel) 0b000: 1 0b001: 2 0b010: 3 0b011: 4 0b100: 5 0b101: 6 0b110: 7 0b111: 8	0x3

ADCH4CR1_1: Address(0x75)				
Bit	Symbol	R/W	Description	Default
7:5	Reserved	RO	Not used	0
4	Reserved	RW	Not used	0
3	EN_PGA_4	RW	PGA enable switch (configure channel4, 6 channels in total,the channel offset address is 0x10*channel) 0: disable 1: enable	0x0
2	PD_PGA1_4	RW	First level of PGA enable switch (configure channel4, 6 channels in total,the channel offset address is 0x10*channel) 1: disable 0: enable	0x0
1	PD_PGA2_4	RW	second level of PGA enable switch (configure channel4, 6 channels in total,the channel offset address is 0x10*channel) 1: disable 0: enable	0x0
0	PD_FILTER_4	RW	turn off the PGA2 filter (configure channel4, 6 channels in total,the channel offset address is 0x10*channel) 1: turn off 0: turn on	0x0

ADCH4CR1_2: Address(0x76)				
---------------------------	--	--	--	--

Bit	Symbol	R/W	Description	Default
7:6	VREF_SEL_4	RW	VRP voltage selection (configure channel4, 6 channels in total,the channel offset address is 0x10*channel) 0b00: 2.4v 0b01: 2.8v 0b10: 3.0v 0b11: 3.1v	0x1
5	VREF_GEN_SEL_4	RW	ADC refrence voltage selection (configure channel4, 6 channels in total,the channel offset address is 0x10*channel) 0: AVDD 1: VRP	0x1
4	VCM_ADJ_4	RW	PGA output common mode voltage selection (configure channel4, 6 channels in total,the channel offset address is 0x10*channel) 0: 0.5xAVDD 1: 0.5xAVDD-0.1	0x0
3	Reserved	RO	Not used	0
2:0	ADC_IBIAS_4	RW	ADC BIAS current control (configure channel4, 6 channels in total,the channel offset address is 0x10*channel) 0b000: 2μA 0b001: 2.5μA 0b010: 3μA 0b011: 3.5μA 0b100: 4μA 0b101: 4.5μA 0b110: 5μA 0b111: 5.5μA	0x4

ADCH4CR1_3: Address(0x77)				
Bit	Symbol	R/W	Description	Default
7	Reserved	RO	Not used	0
6:4	PGA_IBIASE_4	RW	PGA module overall current selection(configure channel4, 8 channels in total,the channel offset address is 0x10*channel +0x7) 0b000: 1μA 0b001: 1.25μA 0b010: 1.5μA 0b011: 1.75μA 0b100: 2μA 0b101: 2.25μA 0b110: 2.5μA 0b111: 2.75μA	0x4
3:2	Reserved	RO	Not used	0
1:0	BW_FILTER_4	RW	PGA RC filter output frequency selection (configure channel4, 6 channels in total,the channel offset address is 0x10*channel) 0b00:50kHz 0b01:62.5kHz 0b10:125kHz 0b11:250kHz	0x3

DACH4CR_0: Address(0x78)				
Bit	Symbol	R/W	Description	Default
7:1	Reserved	RO	Not used	0
0	VDAC_RANGE_4	RW	DAC calibration offset range (configure channel4, 6 channels in total,the channel offset address is 0x10*channel) 0: 0.614xVS/3 1: 0.614x(2xVS/9)	0x0

DACH4CR_1: Address(0x79)				
Bit	Symbol	R/W	Description	Default
7:6	Reserved	RW	Not used	0
5	EN_DAC_CAL_4	RW	enable digital DAC calibration loop operation (configure channel4, 6 channels in total,the channel offset address is 0x10*channel) 0: disable 1: enable	0x0
4	EN_DAC_4	RW	enable calibration offset DAC (configure channel4, 6 channels in total,the channel offset address is 0x10*channel) 0: disable 1: enable	0x0
3	EN_DAC_VIN_4	RW	turn on DAC negative current input (configure channel4, 6 channels in total,the channel offset address is 0x10*channel) 0: turn off 1: turn on	0x1
2	DIR_DAC_4	RW	DAC direction select (configure channel4, 6 channels in total,the channel offset address is 0x10*channel) 0: disable current direction 1: enable current direction	0x0
1	DIR_MODE0_4	RW	DAC direction select (configure channel4, 6 channels in total,the channel offset address is 0x10*channel) 0: disable affect offset 1: enable affect offset	0x0
0	DIR_MODE1_4	RW	DAC direction select (configure channel4, 6 channels in total,the channel offset address is 0x10*channel) 0: disable affect offset 1: enable affect offset	0x1

DACH4CR_2: Address(0x7A)				
Bit	Symbol	R/W	Description	Default
7:0	Reserved	RO	Not used	0

DACH4CR_3: Address(0x7B)				
Bit	Symbol	R/W	Description	Default
7:0	Reserved	RO	Not used	0

DACH4DR_0: Address(0x7C)				
Bit	Symbol	R/W	Description	Default

7:0	DA_L_4	RW	D/A data register[7:0] (configure channel4, 6 channels in total,the channel offset address is 0x10*channel)	0x0
-----	--------	----	---	-----

DACH4DR_1: Address(0x7D)				
Bit	Symbol	R/W	Description	Default
7:3	Reserved	RO	Not used	0
2:0	DA_H_4	RW	D/A data register[10:8] (configure channel4, 6 channels in total,the channel offset address is 0x10*channel)	0x0

DACH4DR_2: Address(0x7E)				
Bit	Symbol	R/W	Description	Default
7:0	AD_OS_L_4	RW	ADC OFFSET residual.directly save the Adc result[7:0],that is, the ADC code, and convert it to two's complement operation when used (configure channel4, 6 channels in total,the channel offset address is 0x10*channel)	0x0

DACH4DR_3: Address(0x7F)				
Bit	Symbol	R/W	Description	Default
7:6	Reserved	RO	Not used	0
5:0	AD_OS_H_4	RW	ADC OFFSET residual.directly save the Adc result[13:8],that is, the ADC code, and convert it to two's complement operation when used (configure channel4, 6 channels in total,the channel offset address is 0x10*channel)	0x0

ADCH5CR0_0: Address(0x80)				
Bit	Symbol	R/W	Description	Default
7	Reserved	RO	Not used	0
6:4	PD_AINP_5	RW	CHx sensor positive input selection (configure channel5, 6 channels in total,the channel offset address is 0x10*channel) 0b000: sensor0 positive 0b001: sensor1 positive 0b010: sensor2 positive 0b011: sensor3 positive	0x0
3	Reserved	RO	Not used	0
2:0	PD_AINN_5	RW	CHx sensor negative input selection (configure channel5, 6 channels in total,the channel offset address is 0x10*channel) 0b000: sensor1 negative 0b001: sensor0 negative 0b010: sensor3 negative 0b011: sensor2 negative	0x0

ADCH5CR0_1: Address(0x81)				
Bit	Symbol	R/W	Description	Default

7	RED_OS_5	RW	offset Residual cancellation enable signal (configure channel5, 6 channels in total,the channel offset address is 0x10*channel) 0: no elimination of residuals 1: elimination of residuals	0x0
6	Reserved	RO	Not used	0
5	PD_DOUBLE_VIN_5	RW	in ADC single-ended mode, turn off the double-ended input (configure channel5, 6 channels in total,the channel offset address is 0x10*channel) 0: double-ended input 1: single-ended input	0x1
4	EN_DIFF_5	RW	ADC input working mode (configure channel5, 6 channels in total,the channel offset address is 0x10*channel) 0: single-ended mode 1: differential mode	0x1
3:2	Reserved	RO	Not used	0
1:0	PD_SW_IN_5	RW	VS1-VS0 analog switch control (configure channel5, 6 channels in total,the channel offset address is 0x10*channel) 0: strobe vs 1: disable	0x3

ADCH5CR0_2: Address(0x82)				
Bit	Symbol	R/W	Description	Default
7:5	Reserved	RO	Not used	0
4:0	SN_MUX_5	RW	negative terminal of DC voltage channel. (configure channel5, 6 channels in total,the channel offset address is 0x10*channel) 0b10000: sensor negative input channel 0b01000: vtemp 0b00100: vs 0b00010: gnd 0b00001: vtemp_n	0x10

ADCH5CR0_3: Address(0x83)				
Bit	Symbol	R/W	Description	Default
7:5	Reserved	RO	Not used	0
4:0	SP_MUX_5	RW	Positive terminal of DC voltage channel. (configure channel5, 6 channels in total,the channel offset address is 0x10*channel) 0b10000: sensor positive input channel 0b01000: vtemp 0b00100: vs 0b00010: gnd 0b00001: vtemp_p	0x10

ADCH5CR1_0: Address(0x84)				
Bit	Symbol	R/W	Description	Default
7	Reserved	RO	Not used	0

6:4	GAIN_PGA1_5	RW	First level of PGA gain selection (configure channel5, 6 channels in total,the channel offset address is 0x10*channel) 0b000: 1 0b001: 16 0b010: 32 0b011: 64 0b100: 128 0b101: 256, do not use when GAIN_PGA2 equals 8 0b110: 256, do not use when GAIN_PGA2 equals 8 0b111: 256, do not use when GAIN_PGA2 equals 8	0x2
3	Reserved	RO	Not used	0
2:0	GAIN_PGA2_5	RW	second level of PGA gain selection (configure channel5, 6 channels in total,the channel offset address is 0x10*channel) 0b000: 1 0b001: 2 0b010: 3 0b011: 4 0b100: 5 0b101: 6 0b110: 7 0b111: 8	0x3

ADCH5CR1_1: Address(0x85)				
Bit	Symbol	R/W	Description	Default
7:5	Reserved	RO	Not used	0
4	Reserved	RW	Not used	0
3	EN_PGA_5	RW	PGA enable switch (configure channel5, 6 channels in total,the channel offset address is 0x10*channel) 0: disable 1: enable	0x0
2	PD_PGA1_5	RW	First level of PGA enable switch (configure channel5, 6 channels in total,the channel offset address is 0x10*channel) 1: disable 0: enable	0x0
1	PD_PGA2_5	RW	second level of PGA enable switch (configure channel5, 6 channels in total,the channel offset address is 0x10*channel) 1: disable 0: enable	0x0
0	PD_FILTER_5	RW	turn off the PGA2 filter (configure channel5, 6 channels in total,the channel offset address is 0x10*channel) 1: turn off 0: turn on	0x0

ADCH5CR1_2: Address(0x86)				
---------------------------	--	--	--	--

Bit	Symbol	R/W	Description	Default
7:6	VREF_SEL_5	RW	VRP voltage selection (configure channel5, 6 channels in total,the channel offset address is 0x10*channel) 0b00: 2.4v 0b01: 2.8v 0b10: 3.0v 0b11: 3.1v	0x1
5	VREF_GEN_SEL_5	RW	ADC refrence voltage selection (configure channel5, 6 channels in total,the channel offset address is 0x10*channel) 0: AVDD 1: VRP	0x1
4	VCM_ADJ_5	RW	PGA output common mode voltage selection (configure channel5, 6 channels in total,the channel offset address is 0x10*channel) 0: 0.5xAVDD 1: 0.5xAVDD-0.1	0x0
3	Reserved	RO	Not used	0
2:0	ADC_IBIAS_5	RW	ADC BIAS current control (configure channel5, 6 channels in total,the channel offset address is 0x10*channel) 0b000: 2μA 0b001: 2.5μA 0b010: 3μA 0b011: 3.5μA 0b100: 4μA 0b101: 4.5μA 0b110: 5μA 0b111: 5.5μA	0x4

ADCH5CR1_3: Address(0x87)				
Bit	Symbol	R/W	Description	Default
7	Reserved	RO	Not used	0
6:4	PGA_IBIASE_5	RW	PGA module overall current selection(configure channel5, 8 channels in total,the channel offset address is 0x10*channel +0x7) 0b000: 1μA 0b001: 1.25μA 0b010: 1.5μA 0b011: 1.75μA 0b100: 2μA 0b101: 2.25μA 0b110: 2.5μA 0b111: 2.75μA	0x4
3:2	Reserved	RO	Not used	0
1:0	BW_FILTER_5	RW	PGA RC filter output frequency selection (configure channel5, 6 channels in total,the channel offset address is 0x10*channel) 0b00:50kHz 0b01:62.5kHz 0b10:125kHz 0b11:250kHz	0x3

DACH5CR_0: Address(0x88)				
Bit	Symbol	R/W	Description	Default
7:1	Reserved	RO	Not used	0
0	VDAC_RANGE_5	RW	DAC calibration offset range (configure channel5, 6 channels in total, the channel offset address is 0x10*channel) 0: 0.614xVS/3 1: 0.614x(2xVS/9)	0x0

DACH5CR_1: Address(0x89)				
Bit	Symbol	R/W	Description	Default
7:6	Reserved	RO	Not used	0
5	EN_DAC_CAL_5	RW	enable digital DAC calibration loop operation (configure channel5, 6 channels in total, the channel offset address is 0x10*channel) 0: disable 1: enable	0x0
4	EN_DAC_5	RW	enable calibration offset DAC (configure channel5, 6 channels in total, the channel offset address is 0x10*channel) 0: disable 1: enable	0x0
3	EN_DAC_VIN_5	RW	turn on DAC negative current input (configure channel5, 6 channels in total, the channel offset address is 0x10*channel) 0: turn off 1: turn on	0x1
2	DIR_DAC_5	RW	DAC direction select (configure channel5, 6 channels in total, the channel offset address is 0x10*channel) 0: disable current direction 1: enable current direction	0x0
1	DIR_MODE0_5	RW	DAC direction select (configure channel5, 6 channels in total, the channel offset address is 0x10*channel) 0: disable affect offset 1: enable affect offset	0x0
0	DIR_MODE1_5	RW	DAC direction select (configure channel5, 6 channels in total, the channel offset address is 0x10*channel) 0: disable affect offset 1: enable affect offset	0x1

DACH5CR_2: Address(0x8A)				
Bit	Symbol	R/W	Description	Default
7:0	Reserved	RO	Not used	0

DACH5CR_3: Address(0x8B)				
Bit	Symbol	R/W	Description	Default
7:0	Reserved	RO	Not used	0

DACH5DR_0: Address(0x8C)				
Bit	Symbol	R/W	Description	Default

7:0	DA_L_5	RW	D/A data register[7:0] (configure channel5, 6 channels in total,the channel offset address is 0x10*channel)	0x0
-----	--------	----	---	-----

DACH5DR_1: Address(0x8D)				
Bit	Symbol	R/W	Description	Default
7:3	Reserved	RO	Not used	0
2:0	DA_H_5	RW	D/A data register[10:8] (configure channel5, 6 channels in total,the channel offset address is 0x10*channel)	0x0

DACH5DR_2: Address(0x8E)				
Bit	Symbol	R/W	Description	Default
7:0	AD_OS_L_5	RW	ADC OFFSET residual.directly save the Adc result[7:0],that is, the ADC code, and convert it to two's complement operation when used (configure channel5, 6 channels in total,the channel offset address is 0x10*channel)	0x0

DACH5DR_3: Address(0x8F)				
Bit	Symbol	R/W	Description	Default
7:6	Reserved	RO	Not used	0
5:0	AD_OS_H_5	RW	ADC OFFSET residual.directly save the Adc result[13:8],that is, the ADC code, and convert it to two's complement operation when used (configure channel5, 6 channels in total,the channel offset address is 0x10*channel)	0x0

ADCH0DR_0: Address(0xB0)				
Bit	Symbol	R/W	Description	Default
7:0	ADDR_0_L	RO	channel 0 value[7:0](configure channel0, 6 channels in total,the channel offset address is 2*channel) single-end input voltage = $(ADDR_x[13:0] / 2^{14}) \times Vref/GAIN_PGA$, differential input voltage = $((ADDR_x[13:0] - 0x2000) / 2^{13}) \times Vref/GAIN_PGA$	0x0

ADCH0DR_1: Address(0xB1)				
Bit	Symbol	R/W	Description	Default
7:6	Reserved	RO	Not used	0
5:0	ADDR_0_H	RO	channel 0 value[13:8](configure channel0, 6 channels in total,the channel offset address is 2*channel) single-end input voltage = $(ADDR_x[13:0] / 2^{14}) \times Vref/GAIN_PGA$, differential input voltage = $((ADDR_x[13:0] - 0x2000) / 2^{13}) \times Vref/GAIN_PGA$	0x0

ADCH1DR_0: Address(0xB2)				
Bit	Symbol	R/W	Description	Default
7:0	ADDR_1_L	RO	channel 1 value[7:0](configure channel1, 6 channels in total,the channel offset address is 2*channel) single-end input voltage = $(ADDR_x[13:0] / 2^{14}) \times Vref/GAIN_PGA$, differential input voltage = $((ADDR_x[13:0] - 0x2000) / 2^{13}) \times Vref/GAIN_PGA$	0x0

ADCH1DR_1: Address(0xB3)				
Bit	Symbol	R/W	Description	Default
7:6	Reserved	RO	Not used	0
5:0	ADDR_1_H	RO	channel 1 value[13:8](configure channel1, 6 channels in total,the channel offset address is 2*channel) single-end input voltage = $(ADDR_x[13:0] / 2^{14}) \times Vref/GAIN_PGA$, differential input voltage = $((ADDR_x[13:0] - 0x2000) / 2^{13}) \times Vref/GAIN_PGA$	0x0

ADCH2DR_0: Address(0xB4)				
Bit	Symbol	R/W	Description	Default
7:0	ADDR_2_L	RO	channel 2 value[7:0](configure channel2, 6 channels in total,the channel offset address is 2*channel) single-end input voltage = $(ADDR_x[13:0] / 2^{14}) \times Vref/GAIN_PGA$, differential input voltage = $((ADDR_x[13:0] - 0x2000) / 2^{13}) \times Vref/GAIN_PGA$	0x0

ADCH2DR_1: Address(0xB5)				
Bit	Symbol	R/W	Description	Default
7:6	Reserved	RO	Not used	0
5:0	ADDR_2_H	RO	channel 2 value[13:8](configure channel2, 6 channels in total,the channel offset address is 2*channel) single-end input voltage = $(ADDR_x[13:0] / 2^{14}) \times Vref/GAIN_PGA$, differential input voltage = $((ADDR_x[13:0] - 0x2000) / 2^{13}) \times Vref/GAIN_PGA$	0x0

ADCH3DR_0: Address(0xB6)				
Bit	Symbol	R/W	Description	Default
7:0	ADDR_3_L	RO	channel 3 value[7:0](configure channel3, 6 channels in total,the channel offset address is 2*channel) single-end input voltage = $(ADDR_x[13:0] / 2^{14}) \times Vref/GAIN_PGA$, differential input voltage = $((ADDR_x[13:0] - 0x2000) / 2^{13}) \times Vref/GAIN_PGA$	0x0

ADCH3DR_1: Address(0xB7)				
Bit	Symbol	R/W	Description	Default
7:6	Reserved	RO	Not used	0
5:0	ADDR_3_H	RO	channel 3 value[13:8](configure channel3, 6 channels in total,the channel offset address is 2*channel) single-end input voltage = $(ADDR_x[13:0] / 2^{14}) \times Vref/GAIN_PGA$, differential input voltage = $((ADDR_x[13:0] - 0x2000) / 2^{13}) \times Vref/GAIN_PGA$	0x0

ADCH4DR_0: Address(0xB8)				
Bit	Symbol	R/W	Description	Default
7:0	ADDR_4_L	RO	channel 4 value[7:0](configure channel4, 6 channels in total,the channel offset address is 2*channel) single-end input voltage = $(ADDR_x[13:0] / 2^{14}) \times Vref/GAIN_PGA$, differential input voltage = $((ADDR_x[13:0] - 0x2000) / 2^{13}) \times Vref/GAIN_PGA$	0x0

ADCH4DR_1: Address(0xB9)				
Bit	Symbol	R/W	Description	Default
7:6	Reserved	RO	Not used	0
5:0	ADDR_4_H	RO	channel 4 value[13:8](configure channel4, 6 channels in total,the channel offset address is 2*channel) single-end input voltage = $(ADDR_x[13:0] / 2^{14}) \times Vref/GAIN_PGA$, differential input voltage = $((ADDR_x[13:0] - 0x2000) / 2^{13}) \times Vref/GAIN_PGA$	0x0

ADCH5DR_0: Address(0xBA)				
Bit	Symbol	R/W	Description	Default
7:0	ADDR_5_L	RO	channel 5 value[7:0](configure channel5, 6 channels in total,the channel offset address is 2*channel) single-end input voltage = $(ADDR_x[13:0] / 2^{14}) \times Vref/GAIN_PGA$, differential input voltage = $((ADDR_x[13:0] - 0x2000) / 2^{13}) \times Vref/GAIN_PGA$	0x0

ADCH5DR_1: Address(0xBB)				
Bit	Symbol	R/W	Description	Default
7:6	Reserved	RO	Not used	0
5:0	ADDR_5_H	RO	channel 5 value[13:8](configure channel5, 6 channels in total,the channel offset address is 2*channel) single-end input voltage = $(ADDR_x[13:0] / 2^{14}) \times Vref/GAIN_PGA$,	0x0

			differential input voltage = $((\text{ADDR_x}[13:0] - 0x2000) / 2^{13}) \times V_{\text{ref}} / \text{GAIN_PGA}$	
--	--	--	---	--

ADMCR_0: Address(0xC0)				
Bit	Symbol	R/W	Description	Default
7	Reserved	RO	Not used	0
6	EN_AD_RST	RW	reset ADC after changing channel 0: disable 1: enable	0x1
5	TRGS	RW	A/D conversion trigger source selection. 0: AD conversion is initiated by software ADST 1: AD conversion is initiated by timer or software ADST	0x0
4:2	ADMD	RW	A/D conversion operation mode control. 0b000: single conversion 0b001: single cycle scan 0b010: finite scan mode1 0b011: finite scan mode2 0b100: infinite scan mode 0b101: burst mode note : software clears ADST bit before changing operation mode	0x2
1	ADIE	RW	A/D interrupt enable control. 0: disable 1: enable	0x1
0	EN_ADC	RW	A/D enable control. 0: disable 1: enable	0x1

ADMCR_1: Address(0xC1)				
Bit	Symbol	R/W	Description	Default
7:4	Reserved	RO	Not used	0
3	ADST	RW	A/D conversion begins. ADST will be automatically cleared by hardware after conversion in Single conversion mode and single-cycle scan mode. A/D conversion will continue until the software writes 0 or the system resets in the wireless periodic scan mode. 0: end 1: start	0x0
2:0	Reserved	RO	Not used	0

ADMCR_2: Address(0xC2)				
Bit	Symbol	R/W	Description	Default

7:4	UNVLD_RS	RW	finite scan mode1 for invalid conversions 0b0000: 0 0b0001: 1 0b0010: 2 0b0011: 3 0b0100: 4 0b0101: 5 0b0110: 6 0b0111: 7 0b1000: 8 0b1001: 9 0b1010: 10 0b1011: 11 0b1100: 12 0b1101: 13 0b1110: 14 0b1111: 15	0x0
3	CAL_S	RW	Selection of operation mode in finite period scan mode 0: direc averaging 1: remove the maximum and minimum values before averaging	0x1
2:0	VALID_NS	RW	finite scan mode2 effective conversions 0b000: 2 0b001: 4 0b010: 8 0b011: 16 0b100: 32 0b101: 64 0b110: 64 0b111: 64 note: in finite period scanning 1 and 2 mode,the ADC data register value is the average of the number of valid conversions	0x2

ADMCR_3: Address(0xC3)				
Bit	Symbol	R/W	Description	Default
7:0	Reserved	RO	Not used	0

ADTDR_0: Address(0xC4)				
Bit	Symbol	R/W	Description	Default
7:0	ADC_WAIT_L	RW	ADC startup wait time(unit is clock period),preferably greater $T = (ADC_WAIT + 1) \times ADC_CLK$	0xff

ADTDR_1: Address(0xC5)				
Bit	Symbol	R/W	Description	Default
7:1	Reserved	RO	Not used	0
0	ADC_WAIT_H	RW	ADC startup wait time(unit is clock period),preferably greater $T = (ADC_WAIT + 1) \times ADC_CLK$	0x1

ADTDR_2: Address(0xC6)				
------------------------	--	--	--	--

Bit	Symbol	R/W	Description	Default
7:0	Reserved	RO	Not used	0

ADTDR_3: Address(0xC7)				
Bit	Symbol	R/W	Description	Default
7:0	Reserved	RO	Not used	0

ADSR_0: Address(0xC8)				
Bit	Symbol	R/W	Description	Default
7	Reserved	RO	Not used	0
6:4	CHANNEL	RO	current conversion channel it indicates the channel being converted when BUSY=1 and indicates the channel to be converted next time when BUSY =1	0x0
3	BUSY	RO	busy/free 0: free 1: busy	0x0
2	CMPF1	RW	comparison flag1.write 1 to clear this flag. 0: no match 1: match	0x0
1	CMPF0	RW	comparison flag0.write 1 to clear this flag. 0: no match 1: match	0x0
0	ADF	RW	end of conversion flag it indicate the end of A/D conversion.write 1 to clear this flag. ADF is set under the following three conditions: 1,at the end of the single conversion mode 2,conversion ends for all specified channels in single scan mode and continuous scan mode 3,in burst mode, the FIFO stores more than 32 conversion result values 0: conversion 1: conversion finish	0x0

ADSR_1: Address(0xC9)				
Bit	Symbol	R/W	Description	Default
7:0	Reserved	RO	Not used	0

ADSR_2: Address(0xCA)				
Bit	Symbol	R/W	Description	Default
7:0	Reserved	RO	Not used	0

ADSR_3: Address(0xCB)				
Bit	Symbol	R/W	Description	Default
7:0	Reserved	RO	Not used	0

ADCMPCR0_0: Address(0xCC)				
Bit	Symbol	R/W	Description	Default
7:0	Reserved	RO	Not used	0

7	Reserved	RO	Not used	0
6:4	CMPCH0	RW	channel selection 0b000: channel 0 0b001: channel 1 0b010: channel2 0b011: channel3 0b100: channel4 0b101: channel5	0x0
3	CMPALLCHEN0	RW	channel selection 0: single channel 1: all channels	0x0
2	CMPCOND0	RW	Compare condition 0: less than 1: greater than or equal	0x0
1	CMPIE0	RW	Compare interrupt enable 0: disable comparator interrupt 1: enable comparator interrupt	0x0
0	CMPEN0	RW	Compare enable 0: disable comparator 1: enable comparator	0x0

ADCMPCR0_1: Address(0xCD)				
Bit	Symbol	R/W	Description	Default
7:6	Reserved	RO	Not used	0
5:0	CMPMATCNT0	RW	Compare matches internal counter is incremented by 1 when the conversion value of the specified channel matches the comparison condition CMPCOND[2], the hardware will set the CMPFx when the counter reaches the set value	0x0

ADCMPCR0_2: Address(0xCE)				
Bit	Symbol	R/W	Description	Default
7:0	CMPD0_L	RW	Compare values[7:0] this 14-bit value will be compared with the conversion result of the specified channel	0x0

ADCMPCR0_3: Address(0xCF)				
Bit	Symbol	R/W	Description	Default
7:6	Reserved	RO	Not used	0
5:0	CMPD0_H	RW	Compare values[13:8] this 14-bit value will be compared with the conversion result of the specified channel	0x0

ADCMPCR1_0: Address(0xD0)				
Bit	Symbol	R/W	Description	Default
7	Reserved	RO	Not used	0

6:4	CMPCH1	RW	channel selection 0b000: channel 0 0b001: channel 1 0b010: channel2 0b011: channel3 0b100: channel4 0b101: channel5	0x0
3	CMPALLCHEN1	RW	channel selection 0: single channel 1: all channels	0x0
2	CMPCOND1	RW	Compare condition 0: less than 1: greater than or equal	0x0
1	CMPIE1	RW	Compare interrupt enable 0: disable comparator interrupt 1: enable comparator interrupt	0x0
0	CMPEN1	RW	Compare enable 0: disable comparator 1: enable comparator	0x0

ADCMPCR1_1: Address(0xD1)				
Bit	Symbol	R/W	Description	Default
7:6	Reserved	RO	Not used	0
5:0	CMPMATCNT1	RW	Compare matches internal counter is incremented by 1 when the conversion value of the specified channel matches the comparison condition CMPCOND[2], the hardware will set the CMPF _x when the counter reaches the set value	0x0

ADCMPCR1_2: Address(0xD2)				
Bit	Symbol	R/W	Description	Default
7:0	CMPD1_L	RW	Compare values[7:0] this 14-bit value will be compared with the conversion result of the specified channel	0x0

ADCMPCR1_3: Address(0xD3)				
Bit	Symbol	R/W	Description	Default
7:6	Reserved	RO	Not used	0
5:0	CMPD1_H	RW	Compare values[13:8] this 14-bit value will be compared with the conversion result of the specified channel	0x0

ADCHEN_0: Address(0xD4)				
Bit	Symbol	R/W	Description	Default
7:0	ADCH_EN	RW	Channel enable 0: disable 1: enable	0x3

ADCHEN_1: Address(0xD5)				
Bit	Symbol	R/W	Description	Default

7:0	Reserved	RO	Not used	0
-----	----------	----	----------	---

ADCEN_2: Address(0xD6)				
Bit	Symbol	R/W	Description	Default
7:0	Reserved	RO	Not used	0

ADCEN_3: Address(0xD7)				
Bit	Symbol	R/W	Description	Default
7:0	Reserved	RO	Not used	0

DAOSDR_0: Address(0xD8)				
Bit	Symbol	R/W	Description	Default
7:0	DAOS_L	RO	DAC offset calibration result	0x0

DAOSDR_1: Address(0xD9)				
Bit	Symbol	R/W	Description	Default
7:3	Reserved	RO	Not used	0
2:0	DAOS_H	RO	DAC offset calibration result	0x0

DAOSDR_2: Address(0xDA)				
Bit	Symbol	R/W	Description	Default
7:2	AD_OS_L	RW	AD offset calibration residual	0x0
1	Reserved	RO	Not used	0
0	DAOSUP	RW	DAC offset calibration update channel DACHDR register enable 0: disable 1: enable	0x0

DAOSDR_3: Address(0xDB)				
Bit	Symbol	R/W	Description	Default
7:0	AD_OS_H	RW	AD offset calibration residual	0x0

FACH0CR0: Address(0xDC)				
Bit	Symbol	R/W	Description	Default
7:0	comp_hi_ch0_l	RW	Force algorithm channel 0 compare high threshold [7:0]	0x0

FACH0CR1: Address(0xDD)				
Bit	Symbol	R/W	Description	Default
7:4	comp_lo_ch0_l	RW	Force algorithm channel 0 compare low threshold [3:0]	0x0
3:0	comp_hi_ch0_h	RW	Force algorithm channel 0 compare high threshold [11:8]	0x0

FACH0CR2: Address(0xDE)				
Bit	Symbol	R/W	Description	Default
7:0	comp_lo_ch0_h	RW	Force algorithm channel 0 compare low threshold [11:4]	0x0

FACH1CR0: Address(0xDF)				
Bit	Symbol	R/W	Description	Default
7:0	comp_hi_ch1_l	RW	Force algorithm channel 1 compare high threshold [7:0]	0x0

FACH1CR1: Address(0xE0)				
Bit	Symbol	R/W	Description	Default
7:4	comp_lo_ch1_l	RW	Force algorithm channel 1 compare low threshold [3:0]	0x0
3:0	comp_hi_ch1_h	RW	Force algorithm channel 1 compare high threshold [11:8]	0x0

FACH1CR2: Address(0xE1)				
Bit	Symbol	R/W	Description	Default
7:0	comp_lo_ch1_h	RW	Force algorithm channel 1 compare low threshold [11:4]	0x0

FACH2CR0: Address(0xE2)				
Bit	Symbol	R/W	Description	Default
7:0	comp_hi_ch2_l	RW	Force algorithm channel 2 compare high threshold [7:0]	0x0

FACH2CR1: Address(0xE3)				
Bit	Symbol	R/W	Description	Default
7:4	comp_lo_ch2_l	RW	Force algorithm channel 2 compare low threshold [3:0]	0x0
3:0	comp_hi_ch2_h	RW	Force algorithm channel 2 compare high threshold [11:8]	0x0

FACH2CR2: Address(0xE4)				
Bit	Symbol	R/W	Description	Default
7:0	comp_lo_ch2_h	RW	Force algorithm channel 2 compare low threshold [11:4]	0x0

FACH3CR0: Address(0xE5)				
Bit	Symbol	R/W	Description	Default
7:0	comp_hi_ch3_l	RW	Force algorithm channel 3 compare high threshold [7:0]	0x0

FACH3CR1: Address(0xE6)				
Bit	Symbol	R/W	Description	Default
7:4	comp_lo_ch3_l	RW	Force algorithm channel 3 compare low threshold [3:0]	0x0
3:0	comp_hi_ch3_h	RW	Force algorithm channel 3 compare high threshold [11:8]	0x0

FACH3CR2: Address(0xE7)				
Bit	Symbol	R/W	Description	Default
7:0	comp_lo_ch3_h	RW	Force algorithm channel 3 compare low threshold [11:4]	0x0

FACHTR0: Address(0xE8)				
Bit	Symbol	R/W	Description	Default
7:0	h_tcmt_l	RW	Force algorithm compare event time count[7:0]	0x0

FACHTR1: Address(0xE9)				
Bit	Symbol	R/W	Description	Default

7:0	h_tcmt_h	RW	Force algorithm compare event time count[15:8]	0x0
-----	----------	----	--	-----

FACFTR: Address(0xEA)				
Bit	Symbol	R/W	Description	Default
7:0	f_tcmt	RW	Force algorithm compare filter time count	0x0

FACR0: Address(0xEB)				
Bit	Symbol	R/W	Description	Default
7:6	Reserved	RO	Not used	0
5	en_alg0	RW	Force algorithm module 0 enable 0: disable 1: enable	0x0
4	base_mode0	RW	Force algorithm module 0 base trigger method 0: negedge trigger 1: posedge trigger	0x0
3:2	Reserved	RO	Not used	0
1:0	en_ch0	RW	Force algorithm module 0 channel select 0b00: channel 0 0b01: channel 1 0b10: channel 2 0b11: channel 3	0x0

FACR1: Address(0xEC)				
Bit	Symbol	R/W	Description	Default
7:6	Reserved	RO	Not used	0
5	en_alg1	RW	Force algorithm module 1 enable 0: disable 1: enable	0x0
4	base_mode1	RW	Force algorithm module 1 base trigger method 0: negedge trigger 1: posedge trigger	0x0
3:2	Reserved	RO	Not used	0
1:0	en_ch1	RW	Force algorithm module 1 channel select 0b00: channel 0 0b01: channel 1 0b10: channel 2 0b11: channel 3	0x0

FAMR: Address(0xED)				
Bit	Symbol	R/W	Description	Default
7:1	Reserved	RO	Not used	0
0	en_force_abs	WO	Force algorithm negative pressing enable, raw data take absolute value, write only 0: disable 1: enable	0x0

FASR0: Address(0xEE)				
Bit	Symbol	R/W	Description	Default
7	Reserved	RO	Not used	0

6	cur_event_force1	WC	Force algorithm module 1 current force event status 0: invalid 1: valid	0x0
5	his_event_force_pos1	WC	Force algorithm module 1 history force event posedge status 0: invalid 1: valid	0x0
4	his_event_force_neg1	WC	Force algorithm module 1 history force event negedge status 0: invalid 1: valid	0x0
3	Reserved	RO	Not used	0
2	cur_event_force0	WC	Force algorithm module 0 current force event status 0: invalid 1: valid	0x0
1	his_event_force_pos0	WC	Force algorithm module 0 history force event posedge status 0: invalid 1: valid	0x0
0	his_event_force_neg0	WC	Force algorithm module 0 history force event negedge status 0: invalid 1: valid (write this register to clear all of history event)	0x0

FASR1: Address(0xEF)				
Bit	Symbol	R/W	Description	Default
7:6	Reserved	RO	Not used	0
5	cur_event_base1	WC	Force algorithm module 1 current base event status 0: invalid 1: valid	0x0
4	his_event_base1	WC	Force algorithm module 1 history base event status 0: invalid 1: valid	0x0
3:2	Reserved	RO	Not used	0
1	cur_event_base0	WC	Force algorithm module 0 current base event status 0: invalid 1: valid	0x0
0	his_event_base0	WC	Force algorithm module 0 history base event status 0: invalid 1: valid (write this register to clear all of history event)	0x0

Tape And Reel Information

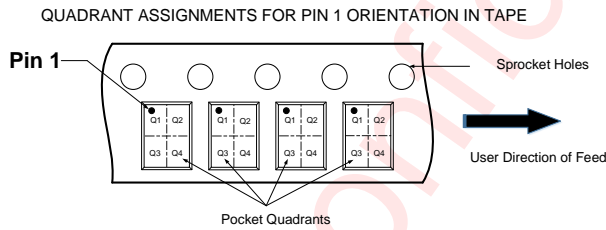
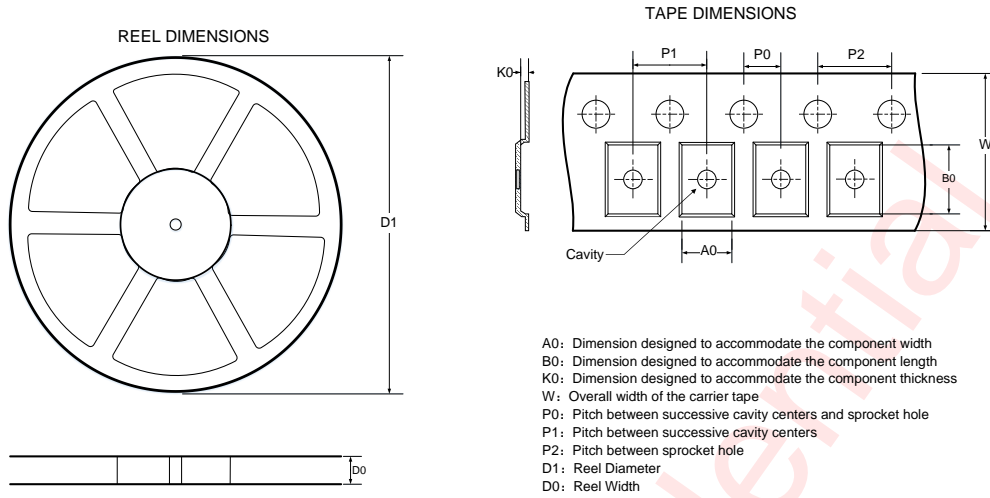

DIMENSIONS AND PIN1 ORIENTATION

D1 (mm)	D0 (mm)	A0 (mm)	B0 (mm)	K0 (mm)	P0 (mm)	P1 (mm)	P2 (mm)	W (mm)	Pin1 Quadrant
179.00	9.00	1.58	1.58	0.45	2.00	4.00	4.00	8.00	Q1

All dimensions are nominal

AW86864CSR Tape And Reel Information

Package Description

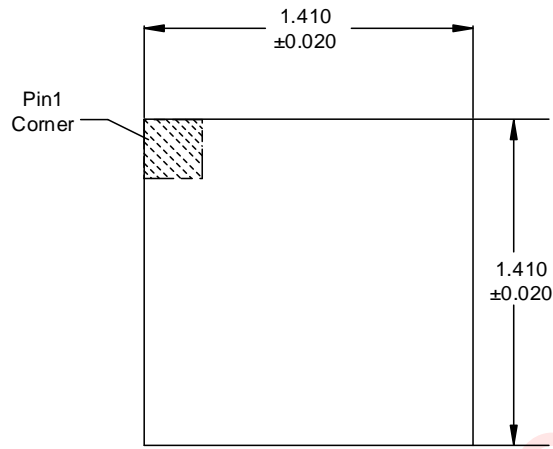

Top View

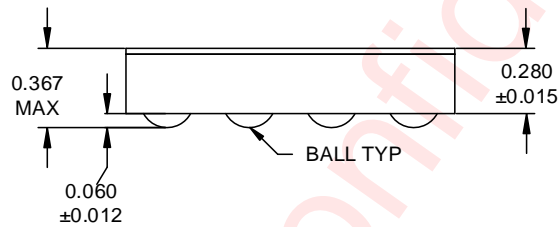

Side View

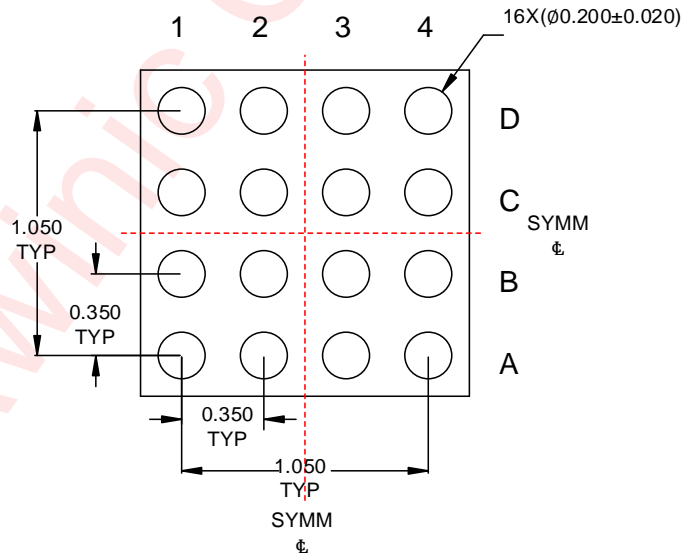

Bottom View

Unit: mm

AW86864CSR Package Description

Land Pattern Data

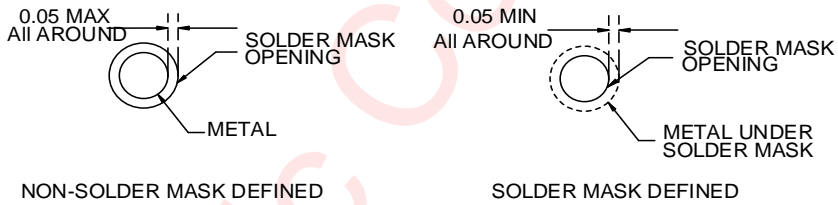
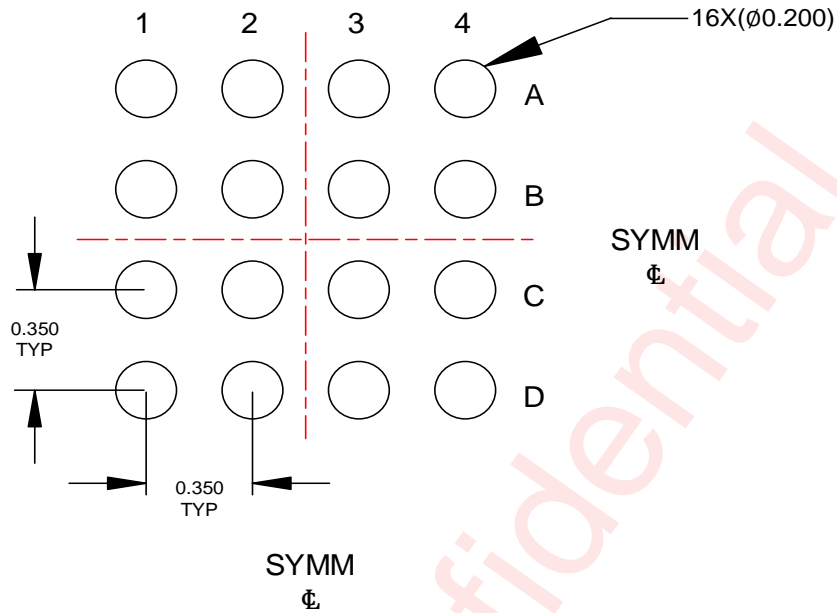

Unit: mm

AW86864CSR Land Pattern Data

Revision History

Version	Date	Change Record
V1.0	Mar. 2021	Officially Released
V1.1	Jun. 2021	Add I ² C device address description
V1.2	Jul. 2021	Update Chip ID
V1.3	Sept. 2021	Update the power consumption of 10Hz, add time calculation formula, improve register description
V1.4	May. 2022	Update Default of HOSC_SEL, and VS voltage adjustment
V1.5	Aug. 2022	Update 0xEE and 0xEF register types
V1.6	Dec. 2022	Update the description of Active Current
V1.7	Mar. 2023	Update the minimum of Analog supply voltage and 1 MHz SDA setup time
V1.8	May.2024	Update the description of Power On Sequence. Modify I2C to I ² C. Modify the description of the chip device address. Delete the register description of 0x23,0x24.

Disclaimer

All trademarks are the property of their respective owners. Information in this document is believed to be accurate and reliable. However, Shanghai AWINIC Technology Co., Ltd (AWINIC Technology) does not give any representations or warranties, expressed or implied, as to the accuracy or completeness of such information and shall have no liability for the consequences of use of such information.

AWINIC Technology reserves the right to make changes to information published in this document, including without limitation specifications and product descriptions, at any time and without notice. Customers shall obtain the latest relevant information before placing orders and shall verify that such information is current and complete. This document supersedes and replaces all information supplied prior to the publication hereof.

AWINIC Technology products are not designed, authorized or warranted to be suitable for use in medical, military, aircraft, space or life support equipment, nor in applications where failure or malfunction of an AWINIC Technology product can reasonably be expected to result in personal injury, death or severe property or environmental damage. AWINIC Technology accepts no liability for inclusion and/or use of AWINIC Technology products in such equipment or applications and therefore such inclusion and/or use is at the customer's own risk.

Applications that are described herein for any of these products are for illustrative purposes only. AWINIC Technology makes no representation or warranty that such applications will be suitable for the specified use without further testing or modification.

All products are sold subject to the general terms and conditions of commercial sale supplied at the time of order acknowledgement.

Nothing in this document may be interpreted or construed as an offer to sell products that is open for acceptance or the grant, conveyance or implication of any license under any copyrights, patents or other industrial or intellectual property rights.

Reproduction of AWINIC information in AWINIC data books or data sheets is permissible only if reproduction is without alteration and is accompanied by all associated warranties, conditions, limitations, and notices. AWINIC is not responsible or liable for such altered documentation. Information of third parties may be subject to additional restrictions.

Resale of AWINIC components or services with statements different from or beyond the parameters stated by AWINIC for that component or service voids all express and any implied warranties for the associated AWINIC component or service and is an unfair and deceptive business practice. AWINIC is not responsible or liable for any such statements.