

Dimensions

Unit:mm

No.	Style	No.	Style
3		6	
4		7	
5		8	

Circuit Diagram

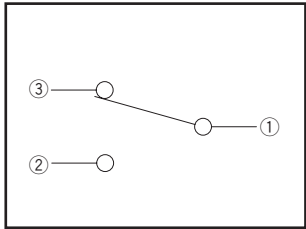

- Detector
- Slide
- Push
- Rotary
- Power
- Dual-in-line Package Type
- General-purpose Type
- Water-proof Type

SPVQA Water-proof Type

Detector

Reference Drawing for Unit Terminals

Unit:mm

Style

Slide

SPVQA10500

Push

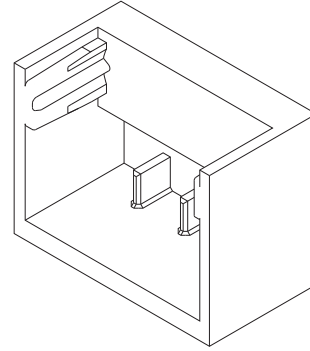
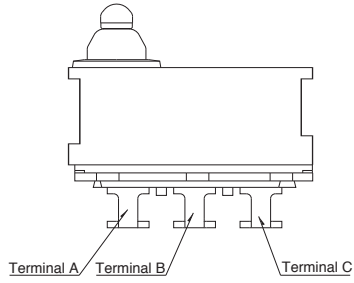

Rotary





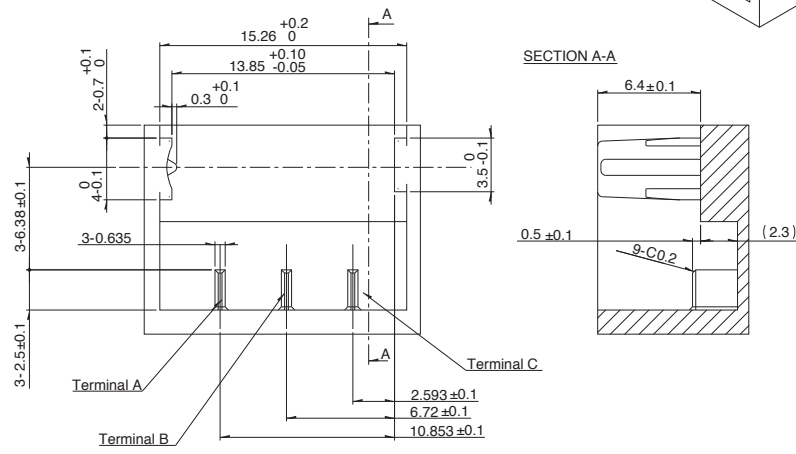



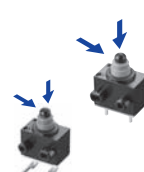

Power

Dual-In-line
Package Type

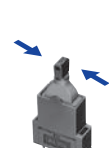

General-
purpose Type

Water-proof
Type

Series		Water-proof Type				
		SPVQ8	SPVQ9	SPVQA	SPVQC	SSCN
Photo						
Operation type		Two-way				
Dimensions (mm)	W	8.3	15.4	15.2	15.4	13
	D	5.3	8.4	6.4	7.4	5
	H	6.5	7.5	7.95	7.5	15
Operating temperature range		-40°C to +85°C				
Automotive use		●	●	●	●	●
Life cycle (availability)						
Poles / Positions		1/1	2/2	1/1 1/2	2/2	1/2
Rating (max.) (Resistive load)		0.1A 12V DC	50mA 26V DC	0.1A 12V DC	50mA 18V DC	0.1A 12V DC
Rating (min.) (Resistive load)		50μA 5V DC				100μA 5V DC
Durability	Operating life without load	300,000cycles 1Ω max. or 1,000,000cycles 3Ω max.	300,000cycles 200mΩ max.	300,000cycles 1Ω max.	300,000cycles 200mΩ max.	100,000cycles 1Ω max.
	Operating life with load Rating (max.) (Resistive load)	300,000cycles 1Ω max. or 1,000,000cycles 3Ω max.	300,000cycles 200mΩ max.	300,000cycles 1Ω max.	300,000cycles 200mΩ max.	100,000cycles 1Ω max.
Electrical performance	Initial contact resistance	500mΩ max.	75mΩ max.	500mΩ max.	75mΩ max.	500mΩ max.
	Insulation resistance	100MΩ min. 500V DC			100MΩ min. 250V DC	100MΩ min. 500V DC
	Voltage proof	500V AC for 1minute			250V AC for 1minute	500V AC for 1minute
Mechanical performance	Terminal strength	3N for 1minute (with terminal) Wire strength 30N for 1minute (with wire)	3N for 1minute			
	Actuator strength	20N				10N
Environmental performance	Cold	-40°C 500h				
	Dry heat	85°C 500h				
	Damp heat	60°C, 90 to 95% RH 500h				
Operation force		1±0.5N				2N max.
Page		60	65	66	69	70

Detector
Slide
Push
Rotary
Power
Dual-In-line Package Type
General-purpose Type
Water-proof Type

Detector Switches Soldering Conditions	71
Detector Switches Cautions	72

Note

- Indicates applicability to all products in the series.

Detector Switches Soldering Conditions

Example of Reflow Soldering Condition

1. Heating method: Double heating method with infrared heater.
2. Temperature measurement: Thermocouple $\phi 0.1$ to 0.2 CA (K) or CC (T) at soldering portion (copper foil surface).
A heat resisting tape should be used for fixed measurement.
3. Temperature profile

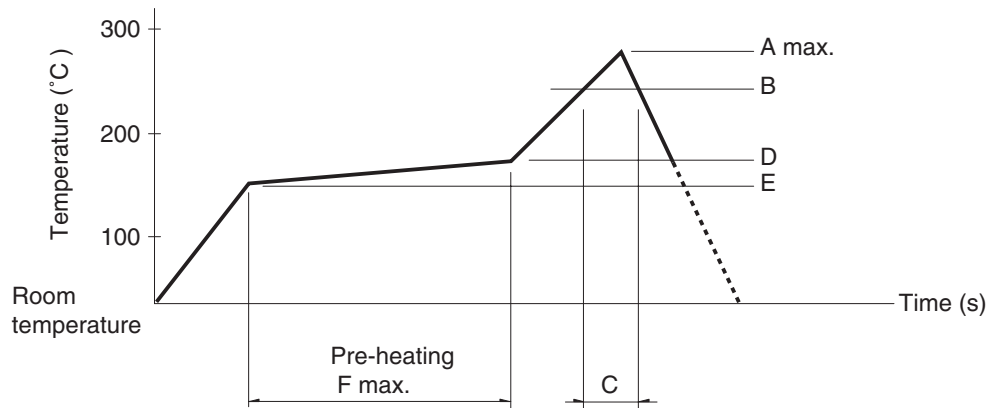

Series (Reflow type)	A (°C) 3s max.	B (°C)	C (s)	D (°C)	E (°C)	F (s)			
SPPB	250	230	40	180	150	120			
SPPW8			35						
SPVE	260		40				180	150	120
SPVL									
SPVM									
SPVN									
SPVR									
SPVS									
SPVT									
SSCM									
SSCQ									
SPVQC	250								

Notes

1. The condition mentioned above is the temperature on the mounting surface of a PC board. There are cases where the PC board's temperature greatly differs from that of the switch, surface depending on the PC board's material, size, thickness, etc.
The above-stated conditions shall also apply to switch surface temperatures.
2. Soldering conditions differ depending on reflow soldering machines.
Prior verification of soldering condition is highly recommended.

Reference for Hand Soldering

Series	Soldering temperature	Soldering time
SPVS, SPVN, SPVT, SPVM, SPVR, SPVE, SPPW8, SSCQ, SSCM, SPVL, SSCT, SPVQC	350±5°C	3s max.
SPVQ1, SPVQ3, SPVQ6, SPVQ7, SPVQ8, SPVQ9, SSCN, SPVQA	300±10°C	3 +1 / 0s
SPPB (Reflow)	300±5°C	5s max.
SSCF, SPPB (For Lead, Dip)	350±10°C	3 +1 / 0s

Reference for Dip Soldering

(For PC board terminal types)

Series	Items		Dip soldering	
	Preheating temperature	Preheating time	Soldering temperature	Duration of immersion
SSCT, SPVQ1, SPVQ3, SPVQ6, SPVQ7, SPVQ8, SPVQ9, SPVQA	100±10°C	60s max.	260±5°C	5±1s
SPPW8, SPPB	100 °C max.	60s max.	255±5°C	5±1s
SSCF	—		260±5°C	5±1s