

# BCD65N320Y1

## N-Channel Silicon Carbide Power MOSFET

650 V, 10A, 320 mΩ



bestirpower

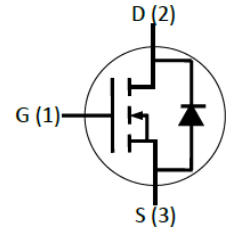
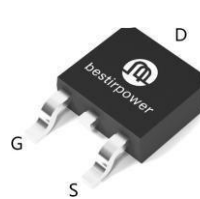
### Features

- Revolutionary semiconductor material Silicon Carbide
- High blocking voltage with low on-resistance
- High-speed switching with very low switching losses
- High-speed and high robust intrinsic body diode

$BV_{DSS, T_C=25^\circ C}$	$I_D, T_C=25^\circ C$	$R_{DS(on), typ}$	$Q_{g, typ}$
650 V	10A	320 mΩ	9.0nC

### Applications

- LED driver
- PD charger
- PC adapter
- Air-conditioning
- E-bike charger



### Absolute Maximum Ratings ( $T_J = 25^\circ C$ unless otherwise noted)

Symbol	Parameter	Value	Unit	
$V_{DSS}$	Drain to Source Voltage	650	V	
$V_{GS}$	Gate to Source Voltage (DC)	-10 / +22	V	
$V_{GSop}$	Recommended Operation Value	0/15	V	
$I_D$	Drain Current	$V_{GS} = 15 V, (T_C = 25^\circ C)$	10	A
		$V_{GS} = 15 V, (T_C = 100^\circ C)$	7.5	
$I_{DM}$	Drain Current	Pulsed	18	A
$P_D$	Power Dissipation	$(T_C = 25^\circ C)$	57	W
		Derate Above $25^\circ C$	0.38	W/ $^\circ C$
$T_J, T_{STG}$	Operating and Storage Temperature Range	-55 to 175	$^\circ C$	

### Thermal Characteristics

Symbol	Parameter	Value	Unit
$R_{thJC}$	MOSFET/Body Diode Junction-Case Thermal Resistance	2.6	K/W
$T_{sold}$	Soldering temperature, wave soldering only allowed at leads	260	$^\circ C$

**Electrical Characteristics** ( $T_J = 25^\circ\text{C}$  unless otherwise noted)

Symbol	Parameter	Test Conditions	Min	Typ	Max	Unit
--------	-----------	-----------------	-----	-----	-----	------

**Off Characteristics**

$BV_{DSS}$	Drain to Source Breakdown Voltage		650	-	-	V
$I_{DSS}$	Zero Gate Voltage Drain Current	$V_{DS} = 650\text{ V}, V_{GS} = 0\text{ V}$	-	0.1	20	$\mu\text{A}$
$I_{GSS}$	Gate-Source Leakage Current	$V_{DS} = 0\text{ V}, V_{GS} = +22\text{ V}$	-	-	+250	nA
$I_{SGS}$	Source-Gate Leakage Current	$V_{DS} = 0\text{ V}, V_{GS} = -10\text{ V}$	-	-	+250	nA

**On Characteristics**

$V_{GS(th)}$	Gate Threshold Voltage	$V_{GS} = V_{DS}, I_D = 10\text{ mA}, T_J = 25^\circ\text{C}$		3.7		V
$R_{DS(on)}$	Static Drain to Source On Resistance	$V_{GS} = 15\text{ V}, I_D = 4\text{ A}, T_J = 25^\circ\text{C}$		320	440	mΩ
		$V_{GS} = 15\text{ V}, I_D = 4\text{ A}, T_J = 175^\circ\text{C}$		336		mΩ

**Dynamic Characteristics**

$C_{iss}$	Input Capacitance	$V_{GS} = 0\text{ V}, V_{DS} = 650\text{ V}, f = 1\text{ MHz}$	-	223	-	pF
$C_{oss}$	Output Capacitance		-	21	-	
$C_{riss}$	Reverse Capacitance		-	3.6	-	
$Q_{g(tot)}$	Total Gate Charge	$V_{DS} = 400\text{ V}, I_D = 4\text{ A}, V_{GS} = 0\text{ V} / 15\text{ V}$	-	9	-	nC
$Q_{gs}$	Gate to Source Charge		-	3.6	-	
$Q_{gd}$	Gate to Drain "Miller" Charge		-	1.2	-	
$R_G$	Internal Gate Resistance	$f = 1\text{ MHz}, V_{AC} = 25\text{ mV}$	-	26	-	Ω

**Switching Characteristics**

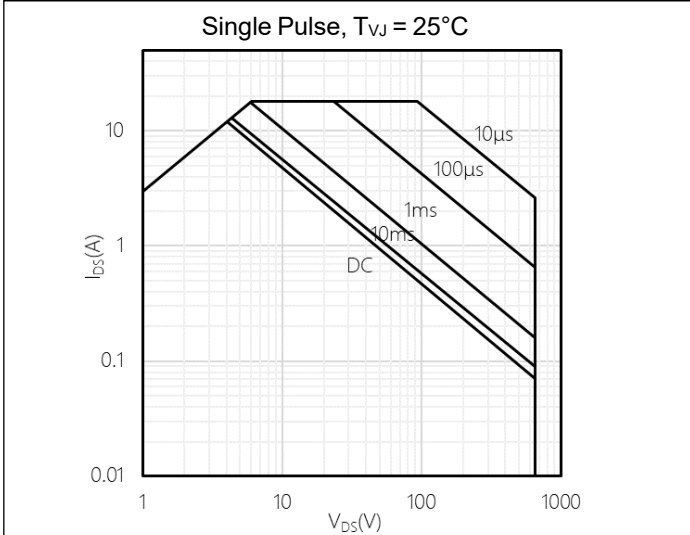
$t_{d(on)}$	Turn-On Delay Time	$V_{GS} = 0/15\text{ V}, L = 600\text{ }\mu\text{H}$ $V_{DS} = 400\text{ V}, I_D = 4\text{ A},$ $R_{G(on)} = 4.3\text{ }\Omega, R_{G(off)} = 4.3\text{ }\Omega$	-	6.3	-	ns
$t_r$	Turn-On Rise Time		-	17.4	-	
$t_{d(off)}$	Turn-Off Delay Time		-	14.3	-	
$t_f$	Turn-Off Fall Time		-	14.8	-	
$E_{on}$	Turn-On Switching Energy		-	35.1	-	$\mu\text{J}$
$E_{off}$	Turn-Off Switching Energy		-	3.02	-	

**Source-Drain Diode Characteristics**

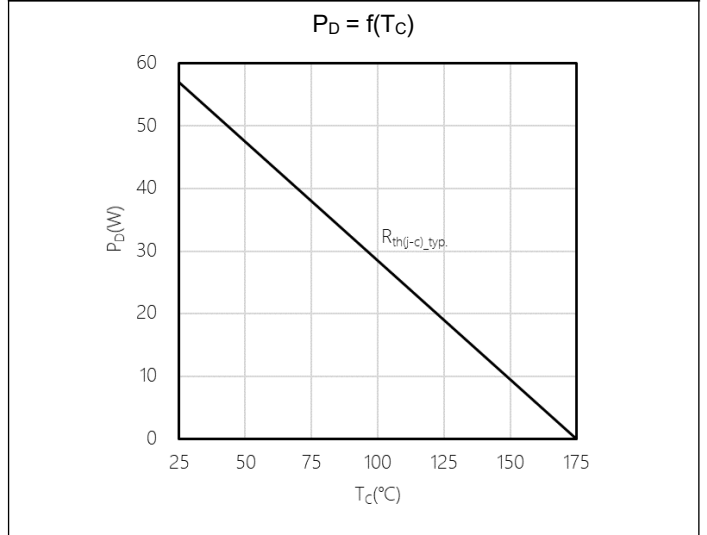
$V_{SD}$	Body Diode Forward Voltage	$V_{GS} = 0\text{ V}, I_{SD} = 2\text{ A}, T_C = 25^\circ\text{C}$	-	3.5	-	V
		$V_{GS} = 0\text{ V}, I_{SD} = 2\text{ A}, T_C = 175^\circ\text{C}$	-	2.9	-	V
$t_{rr}$	Reverse Recovery Time	$V_{DS} = 400\text{ V}, V_{GS} = 0\text{ V}, I_{SD} = 4\text{ A},$ $di/dt = 1.2\text{ kA}/\mu\text{s}$	-	9.2	-	ns
$Q_{rr}$	Reverse Recovery Charge		-	25	-	nC
$I_{rrm}$	Peak Reverse Recovery Current		-	4.5	-	A

### Typical Performance Characteristics

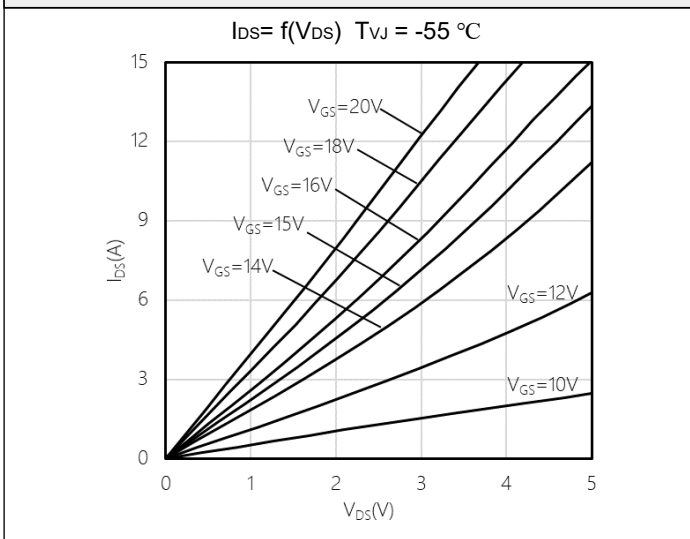
**Figure 1. Safe operating area (SOA)**



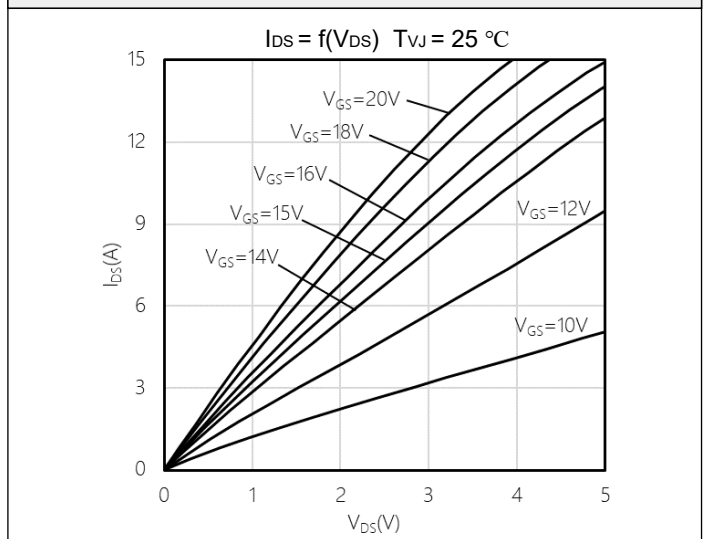
**Figure 2. Power dissipation as a function of case temperature limited by bond wire**



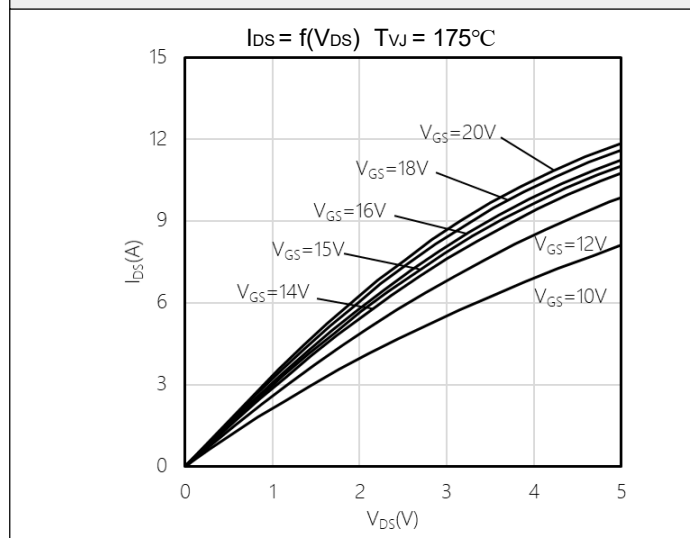
**Figure 3. Typical output characteristic, VGS as parameter**



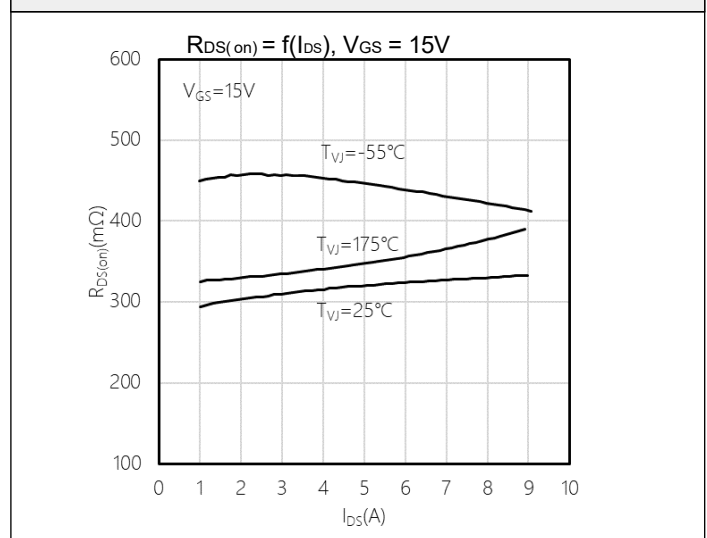
**Figure 4. Typical output characteristic, VGS as parameter**



**Figure 5. Typical output characteristic, VGS as parameter**

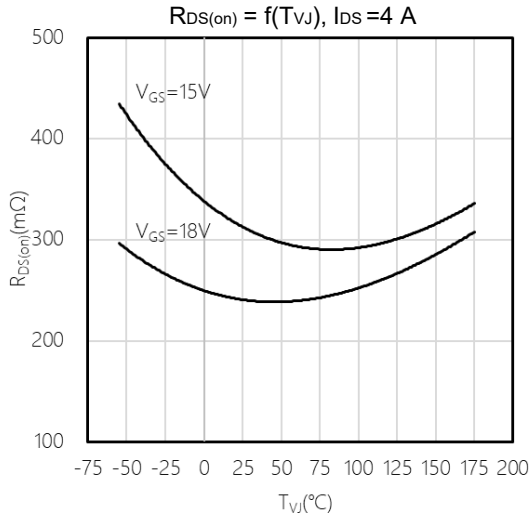


**Figure 6. Typical on-state resistance as a function of drain current**

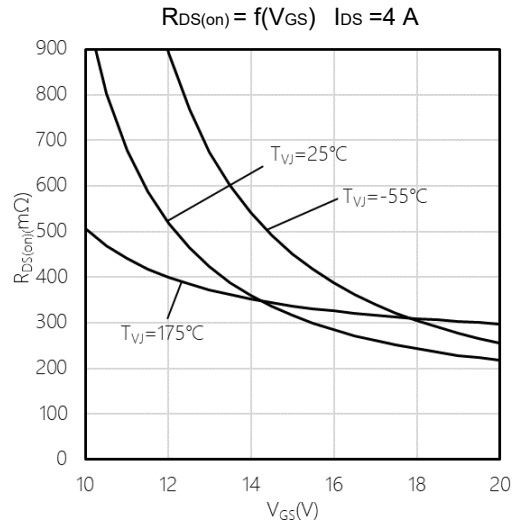


### Typical Performance Characteristics

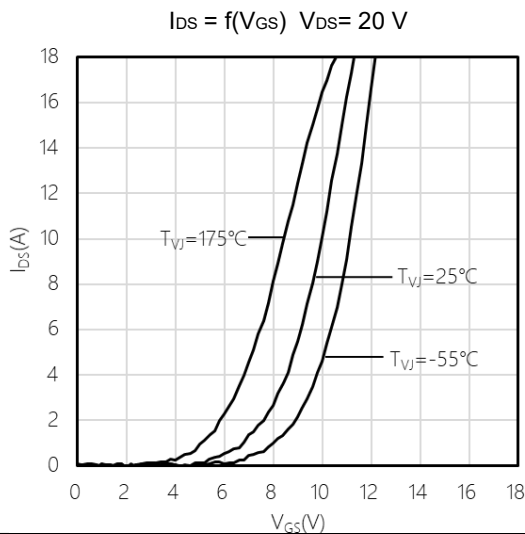
**Figure 7. Typical on-state resistance as a function of temperature**



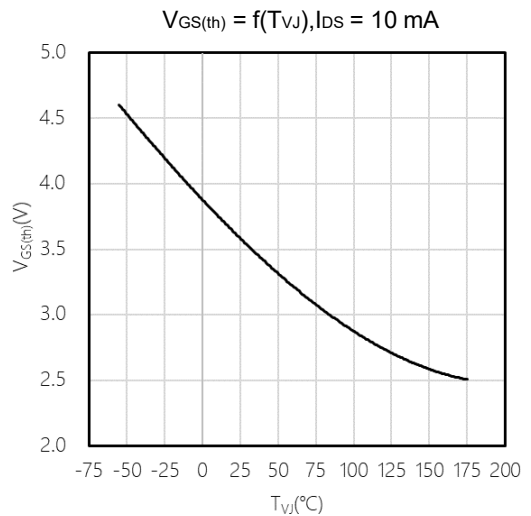
**Figure 8. Typical on-state resistance as a function of  $V_{GS}$**



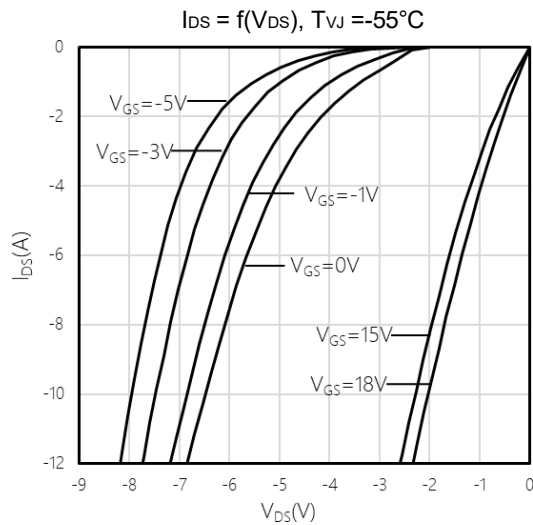
**Figure 9. Typical transfer characteristic**



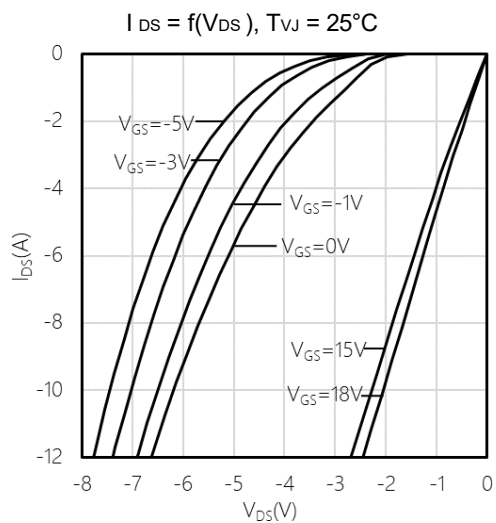
**Figure 10. Typical gate-source threshold voltage as a function of junction temperature**



**Figure 11. Typical reverse drain current as function of reverse drain voltage,  $V_{GS}$  as parameter**

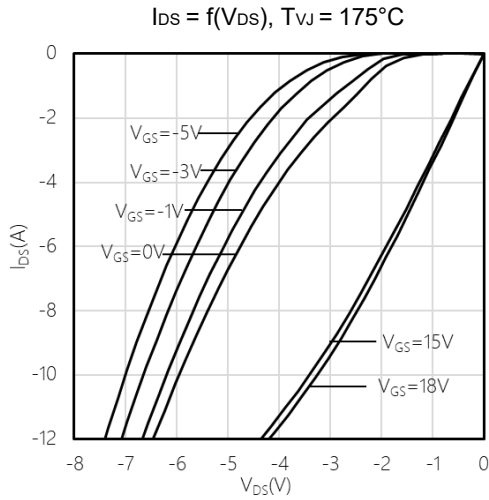


**Figure 12. Typical reverse drain current as function of reverse drain voltage,  $V_{GS}$  as parameter**

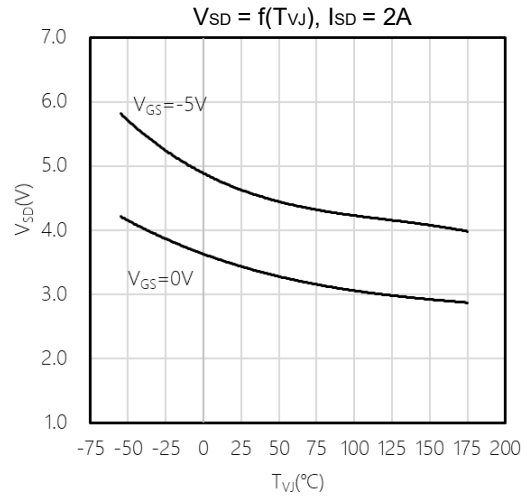


## Typical Performance Characteristics

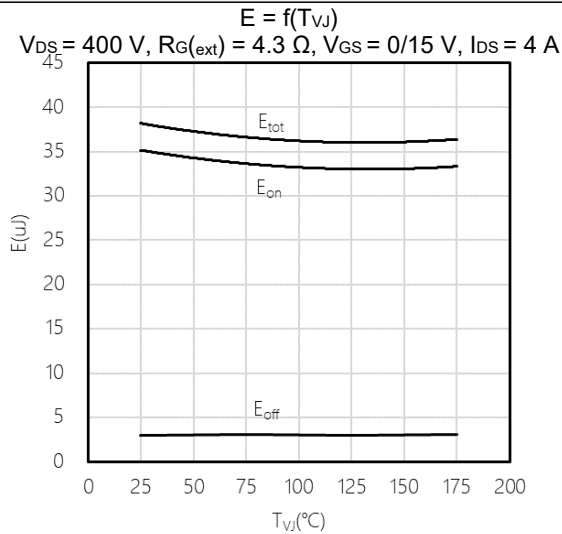
**Figure 13. Typical reverse drain current as function of reverse drain voltage, VGS as parameter**



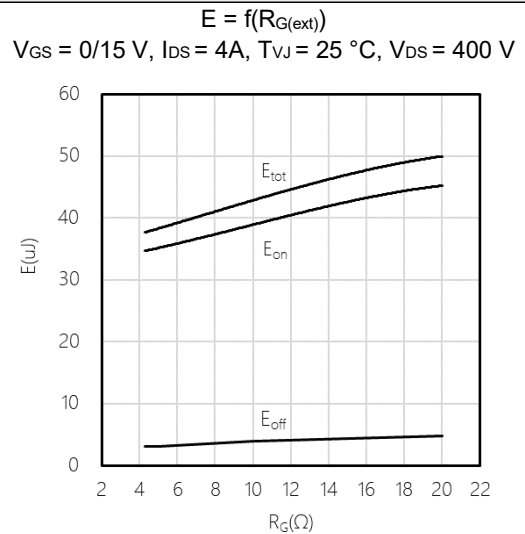
**Figure 14. Typical reverse drain voltage as function of junction temperature**



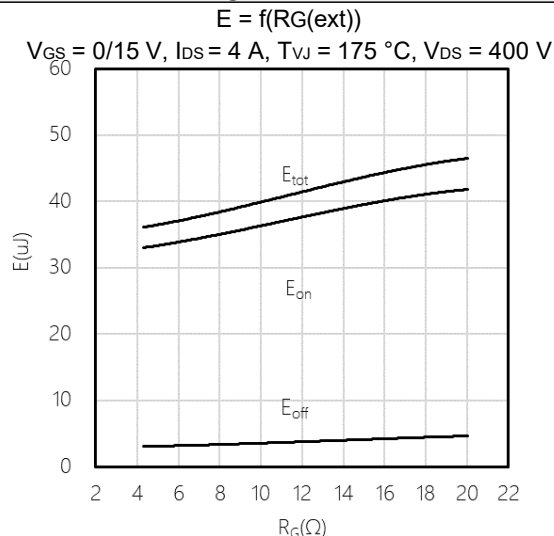
**Figure 15. Typical switching energy as a function of junction temperature**



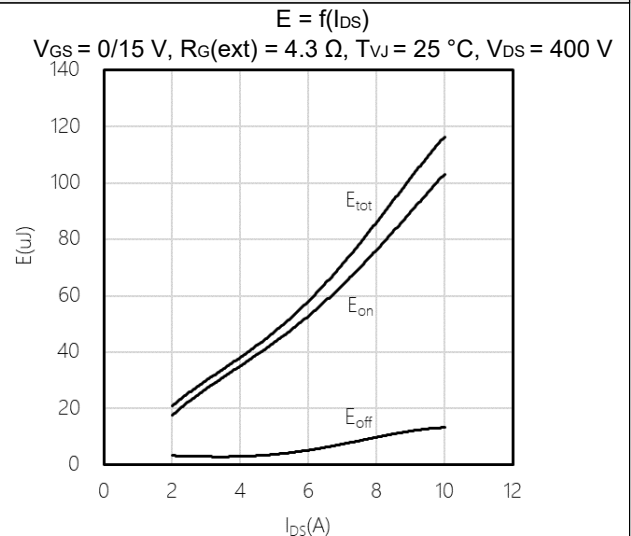
**Figure 16. Typical switching energy losses as a function of gate resistance**



**Figure 17. Typical switching energy losses as a function of gate resistance**

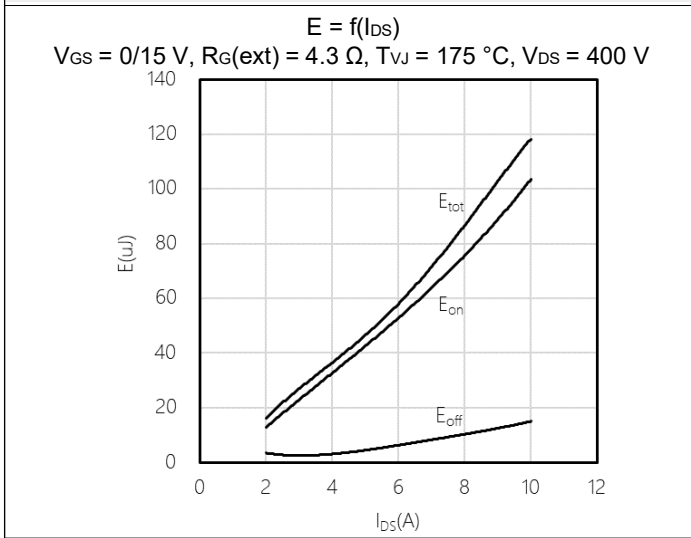


**Figure 18. Typical switching energy losses as a function of IDS**

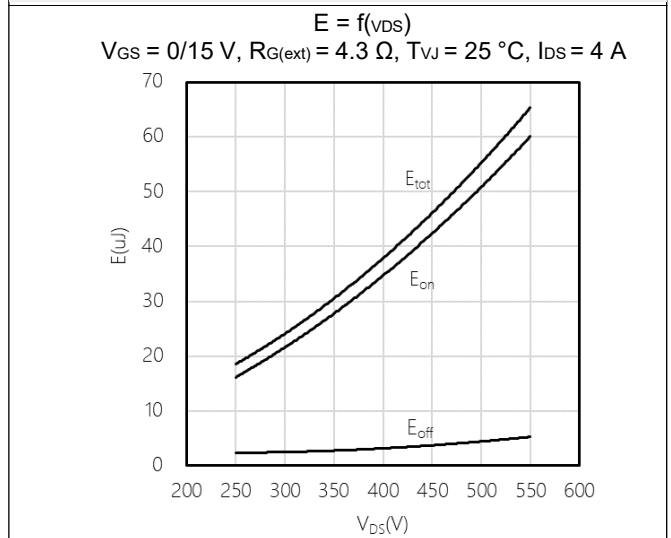


## Typical Performance Characteristics

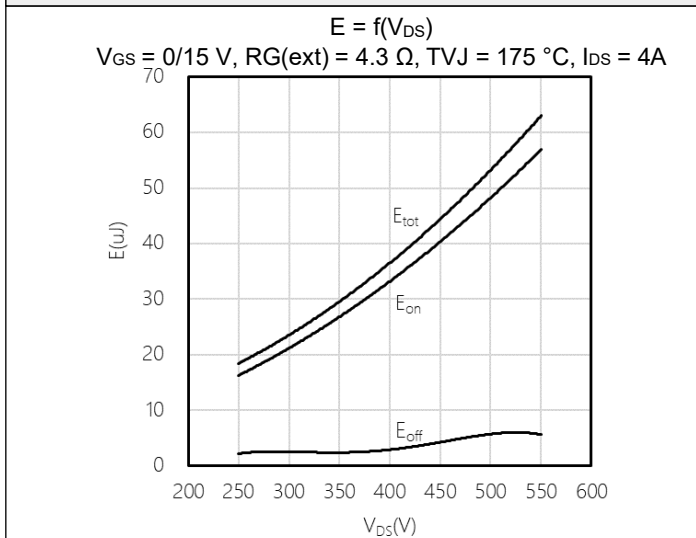
**Figure 19. Typical switching energy losses as a function of  $I_{DS}$**



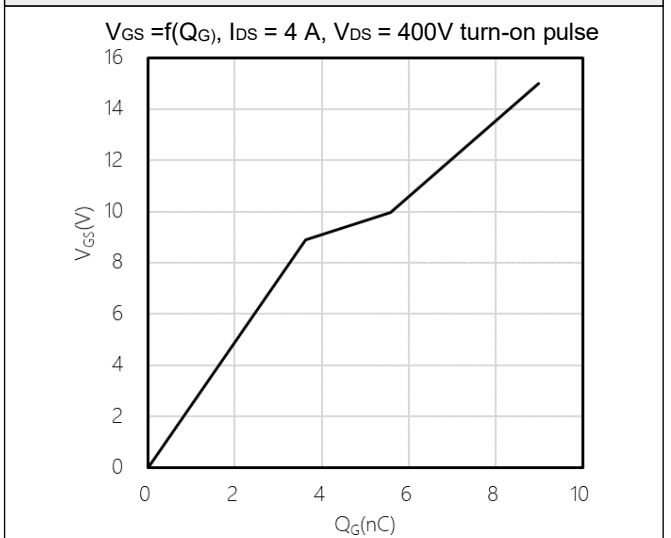
**Figure 20. Typical switching energy losses as a function of  $V_{DS}$**



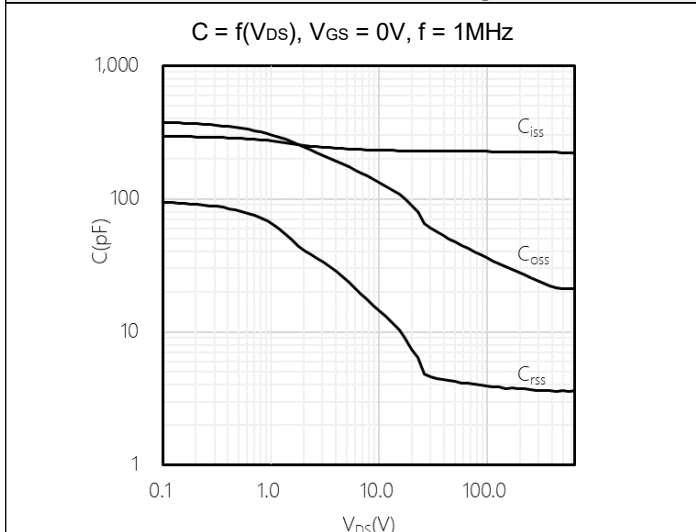
**Figure 21. Typical switching energy losses as a function of  $V_{DS}$**



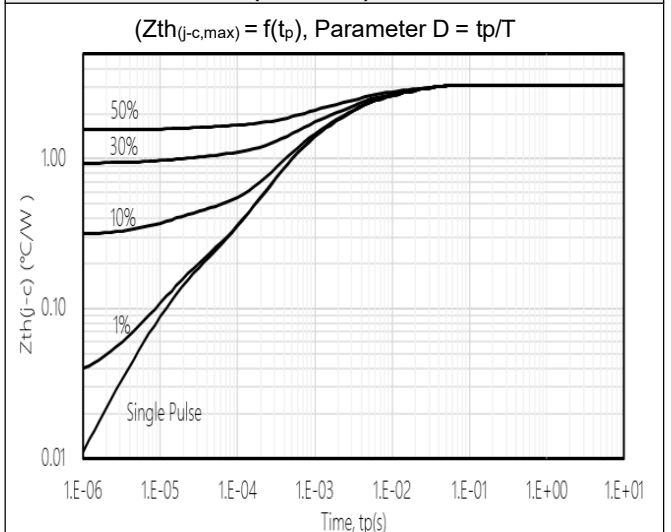
**Figure 22. Typical gate charge**



**Figure 23. Typical capacitance as a function of drain-source voltage**

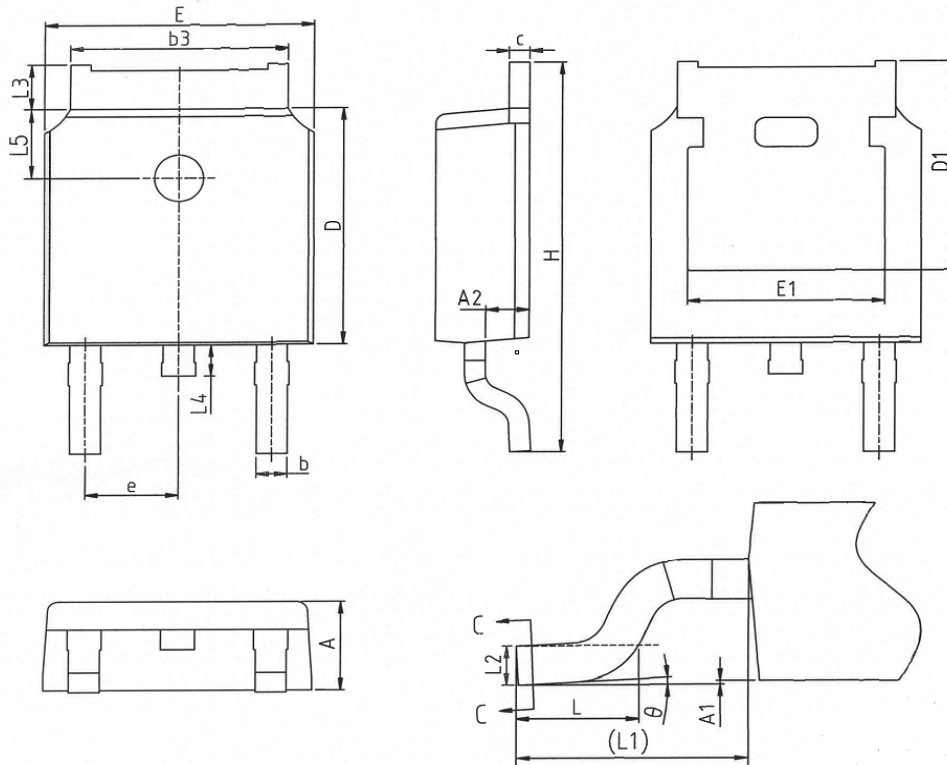


**Figure 24. Transient thermal resistance (MOSFET)**



**Package Outlines**

**D-Pak**



**COMMON DIMENSIONS**

SYMBOL	mm		
	MIN	NOM	MAX
A	2.20	2.30	2.38
A1	0.00	-	0.12
A2	0.97	1.07	1.17
b	0.68	0.78	0.90
b3	5.20	5.33	5.46
c	0.43	0.53	0.61
D	5.98	6.10	6.22
D1	5.30REF		
E	6.40	6.60	6.73
E1	4.63	-	-
e	2.286BSC		
H	9.40	10.10	10.50
L	1.38	1.50	1.75
L1	2.90REF		
L2	0.51BSC		
L3	0.88	-	1.28
L4	0.50	-	1.00
L5	1.65	1.80	1.95
θ	0°	-	8°

\* Dimensions in millimeters

## Package Marking and Ordering Information

Part Number	Top Marking	Package	Packing Method	Quantity
BCD65N320Y1	BCD65N320Y1	DPAK	Tape & Reel	2500 units

## Disclaimer

Bestirpower reserve the right to make changes, corrections, enhancements, modifications, and improvements to Bestirpower products and/or to this document at any time without notice.

The information given in this document shall in no event be regarded as a guarantee of conditions or characteristics. Bestirpower does not assume any liability for infringement of patents, copyrights, or other intellectual property rights of third parties by or arising from the use of Products or technical information described in this document.

This document is the property of Bestirpower Co., LTD., and not allowed to copy or transformed to other format if not under the authority approval.

© 2025 Bestirpower – All rights reserved