

High Sensitivity Micropower Unipolar Hall-effect Switch

Features

- High sensitive unipolar operation.
- Micropower operation.
- Typ 0.45 μ A (average :V_{DD}=1.8V).
- Ultra small package:
DFN 1.4mm \times 1.1mm \times 0.37mm-4L.
- On board voltage regulator for 1.6V to 5.5V range.
- Wide operating temperature range:
-40 $^{\circ}$ C to 85 $^{\circ}$ C.
- ESD (HBM) > 6KV.

Applications

- Smartphone.
- Notebook computer.
- Handheld gaming consoles.
- Bluetooth headset.
- DV.
- Contact-less switch, Level, proximity and position switches in consumer products.

General Description

AW86503DNR is a high-sensitivity micropower unipolar Hall effect switch IC with internal pull up and pull down capability. AW86503DNR uses a hibernating clocking system to reduce power consumption, which the total power consumption in normal operation is typically 0.45 μ A with a 1.8V power source. Mainly designed for portable devices such as laptop computer, smartphone and bluetooth headset etc. The supply range of AW86503DNR is 1.6V to 5.5V to support portable equipment. To minimize PCB space, the AW86503DNR has ultra small SON package: DFN 1.4mm \times 1.1mm \times 0.37mm-4L.

The OUTN is activity with a north pole of sufficient magnetic field strength. When the magnetic flux density perpendicular to the package is large than operate point(BopN) , the output will be turned on (pulled low) and held until B is lower than release point (BrpN). The OUTS is activity with a south pole of sufficient magnetic field strength. When the magnetic flux density perpendicular to the package is large than operate point(BopS) , the output will be turned on (pulled low) and held until B is lower than release point (BrpS).

Typical Application Circuit



Figure 1 Typical Application Circuit of AW86503DNR

Pin Configuration And Top Mark

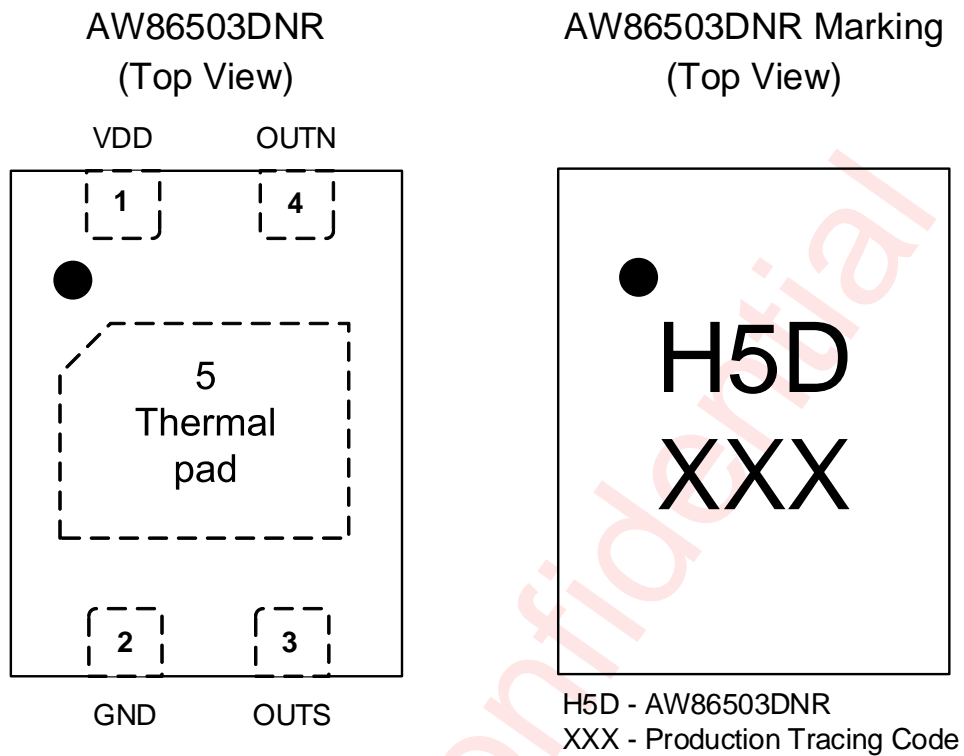

Figure 2 Pin Configuration and Top Mark

Pin Definition

NO	Name	Description
1	VDD	Power Supply
2	GND	Ground
3	OUTS	S pole detection output
4	OUTN	N pole detection output
5	Thermal pad	Not Connect

Functional Block Diagram

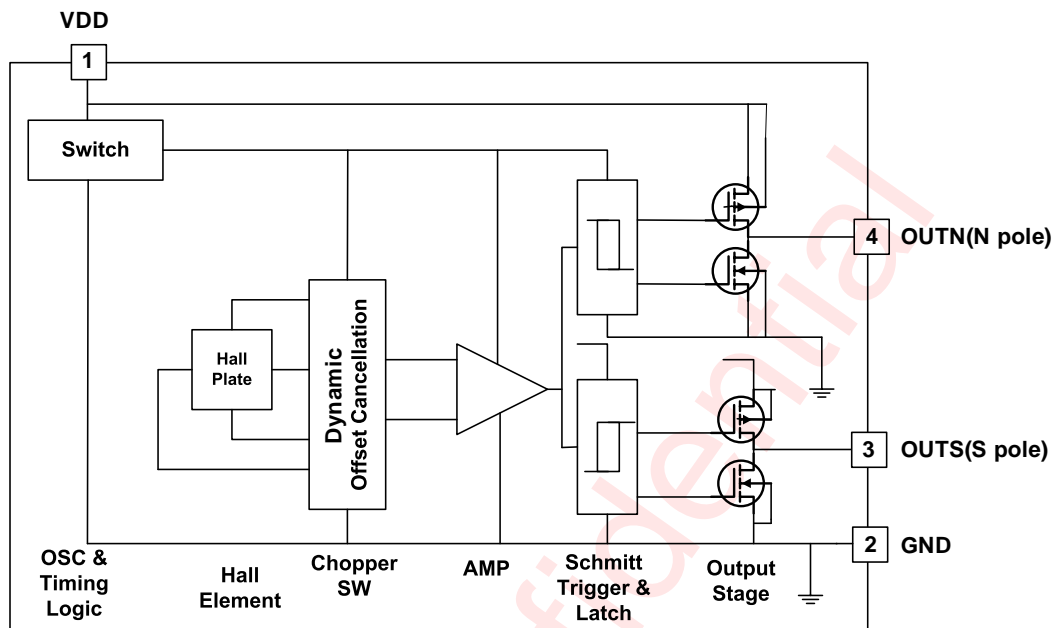

Figure 3 Functional Block Diagram

Ordering Information

Part Number	Temperature	Package	Marking	Moisture Sensitivity Level	Environmental Information	Delivery Form
AW86503DNR	-40°C~85°C	DFN 1.4mm×1.1mm x0.37mm-4L	H5D	MSL1	ROHS+HF	4500 units/ Tape and Reel

Detailed Functional Description

The OUTN is activity with a north pole of sufficient magnetic field strength. When the magnetic flux density perpendicular to the package is larger than operate point(BopN) , the output will be turned on (pulled low) and held until B is lower than release point (BrpN). The OUTS is activity with a south pole of sufficient magnetic field strength. When the magnetic flux density perpendicular to the package is larger than operate point(BopS) , the output will be turned on (pulled low) and held until B is lower than release point (BrpS).

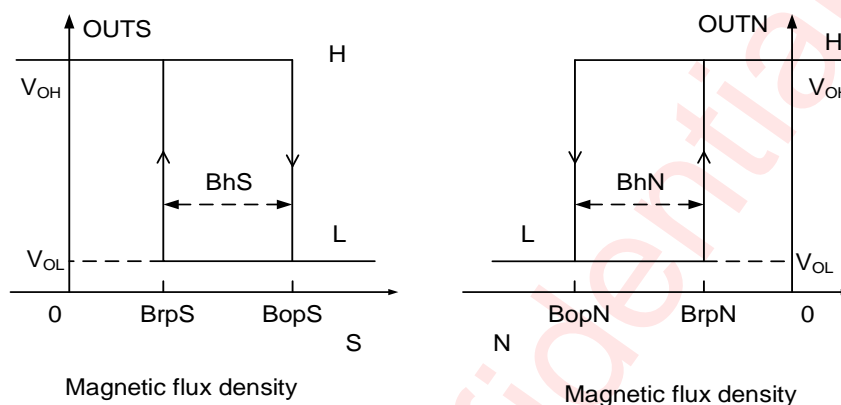

Figure 4 The Working Process of AW86503DNR

Absolute Maximum Ratings ^(NOTE1)

PARAMETERS	RANGE
Supply Voltage	-0.3V to 6V
Supply Current	4mA
Output Voltage	-0.4V to $V_{DD}+0.4V$
Output Current	4mA
Operating Ambient Temperature T_A	-40°C to 85°C
Storage Temperature T_{STG}	-65°C to 150°C
Junction temperature T_J	-50°C to 165°C
Magnetic Flux	No limit
Lead temperature (soldering 10 seconds)	260°C
ESD Rating ^(NOTE2 3)	
Human Body Model (HMB) ESD capability	±6000V
Charged-device model (CDM) ESD capability	±1500V
Latch-up	
Test Condition: JESD78E	+IT: 200mA
	-IT: 200mA

NOTE1: Conditions out of those ranges listed in "absolute maximum ratings" may cause permanent damages to the device. In spite of the limits above, functional operation conditions of the device should within the ranges listed in "recommended operating conditions". Exposure to absolute-maximum-rated conditions for prolonged periods may affect device reliability.

NOTE2: The human body model test method: ESDA/JEDEC JS -001-2017.

NOTE3: Charge Device Model test method: ESDA/JEDEC JS-002-2018.

Electrical Characteristics

Parameters Specification ($V_{DD}=3.3V$ supply, $T_A = -40^{\circ}C$ to $85^{\circ}C$ except where otherwise specified.)

Symbol	Characteristic	Test Conditions	Min	Typ	Max	Unit
V_{DD}	Supply Voltage	Operating, $T_J < 165^{\circ}C$	1.6		5.5	V
$I_{DD}(\text{awake})$ (Note1)	Supply Current	During awake period, $T_A = 25^{\circ}C$, $V_{DD}=3.3V$	-	0.95	1.3	mA
$I_{DD}(\text{sleep})$	Supply Current	During sleep period, $T_A = 25^{\circ}C$, $V_{DD}=3.3V$	-	0.4	-	μA
$I_{DD}(\text{avg})$ (Note1)	Average supply current	$T_A = 25^{\circ}C$, $V_{DD} = 1.8V$		0.45		μA
		$T_A = 25^{\circ}C$, $V_{DD} = 3.3V$		0.7		μA
V_{OL}	Output low voltage(on)	$I_{OUT} = 1\text{ mA}$	-	0.1	0.2	V
V_{OH}	Output high voltage(off)	$I_{OUT} = -1\text{ mA}$	$V_{DD}-0.2$	$V_{DD}-0.1$	-	V
T_{awake} (Note1)	Awake time	(note)	-	40	60	μs
T_{period}	Period	(note)	-	200	280	ms
D.C.	Duty cycle	-	-	0.02	-	%
f_c	Chopping Frequency		-	500	-	kHz
I_{OFF} (Note1)	Output Leakage Current	$V_{OUT} = 5.5\text{ V}$, Switch state = off	-	-	0.1	μA

Note: Maximum and minimum parameters values over operating temperature range are not tested in production. They are guaranteed by design, characterization and process control. The magnetic field strength (Gauss) required to cause the switch to change state (operate and release) will be as specified in the magnetic characteristics. To test the switch against the specified magnetic characteristics, the switch must be placed in a uniform magnetic field.

Note1: Minimum and/or maximum limit is guaranteed by design and by statistical analysis of device characterization data. The specification is not guaranteed by production testing.

Magnetic Characteristics

Magnetic Characteristics ($T_A=+25^{\circ}\text{C}$, $V_{DD}=3.3\text{V}$, unless otherwise specified.)

(1 mT=10 Gauss)

Symbol	Characteristics	Test condition	Min	Typ	Max	Unit
Bops (south pole to part marking side)	Operation Point	$V_{DD}=1.6\text{V to }5.5\text{V}$, $T_A=-40^{\circ}\text{C to }85^{\circ}\text{C}$	13	30	40	Gauss
Bopn (north pole to part marking side)		$V_{DD}=1.6\text{V to }5.5\text{V}$, $T_A=-40^{\circ}\text{C to }85^{\circ}\text{C}$	-40	-30	-13	
Brps (south pole to part marking side)	Release Point	$V_{DD}=1.6\text{V to }5.5\text{V}$, $T_A=-40^{\circ}\text{C to }85^{\circ}\text{C}$	10	20	30	
Brpn (north pole to part marking side)		$V_{DD}=1.6\text{V to }5.5\text{V}$, $T_A=-40^{\circ}\text{C to }85^{\circ}\text{C}$	-30	-20	-10	
Bhy ($ \text{Bopx} - \text{Brpx} $)	Hysteresis	$V_{DD}=1.6\text{V to }5.5\text{V}$, $T_A=-40^{\circ}\text{C to }85^{\circ}\text{C}$	-	10	-	

Notes: Typical data is at $T_A=25^{\circ}\text{C}$, $V_{DD}=3.3\text{V}$.

Maximum and minimum parameters values over operating temperature range are not tested in production. They are guaranteed by design, characterization and process control. The magnetic characteristics may vary with supply voltage, operating temperature and after soldering.

Typical Characteristics

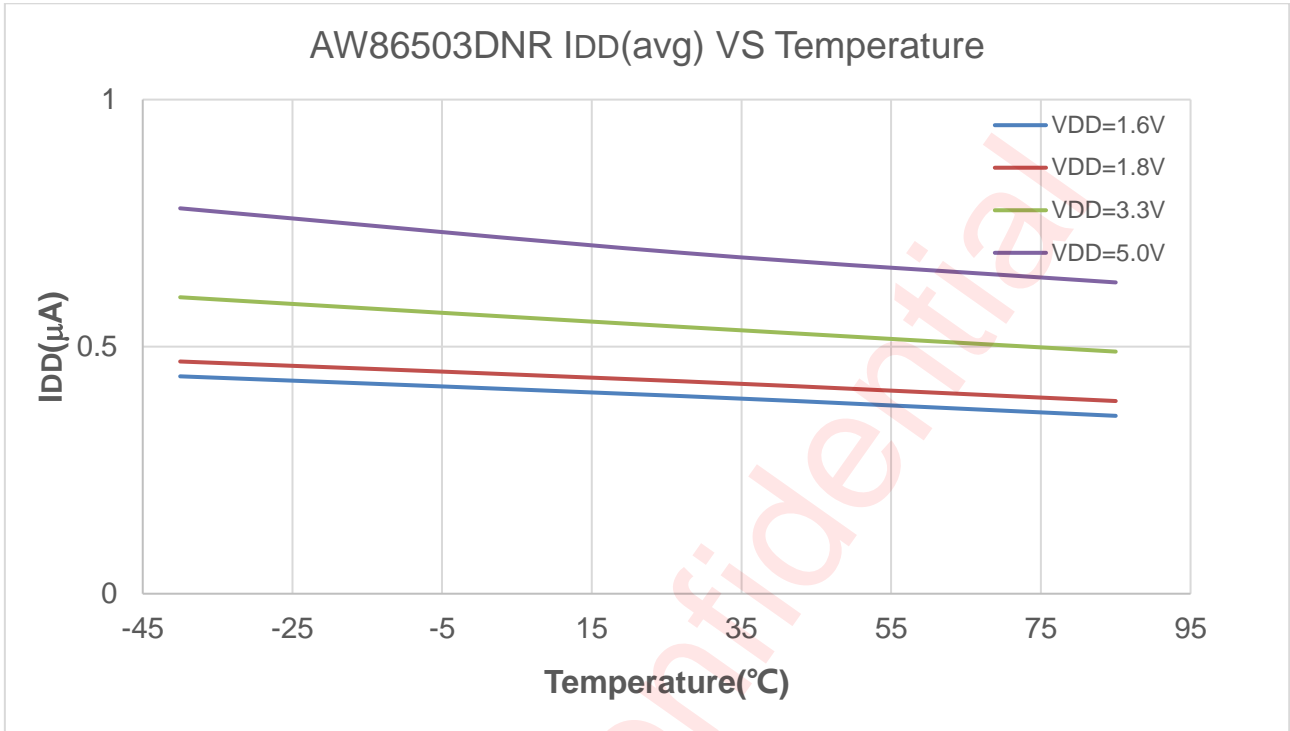

Ambient Temperature Ta[°C] I_{DD} vs. Ta

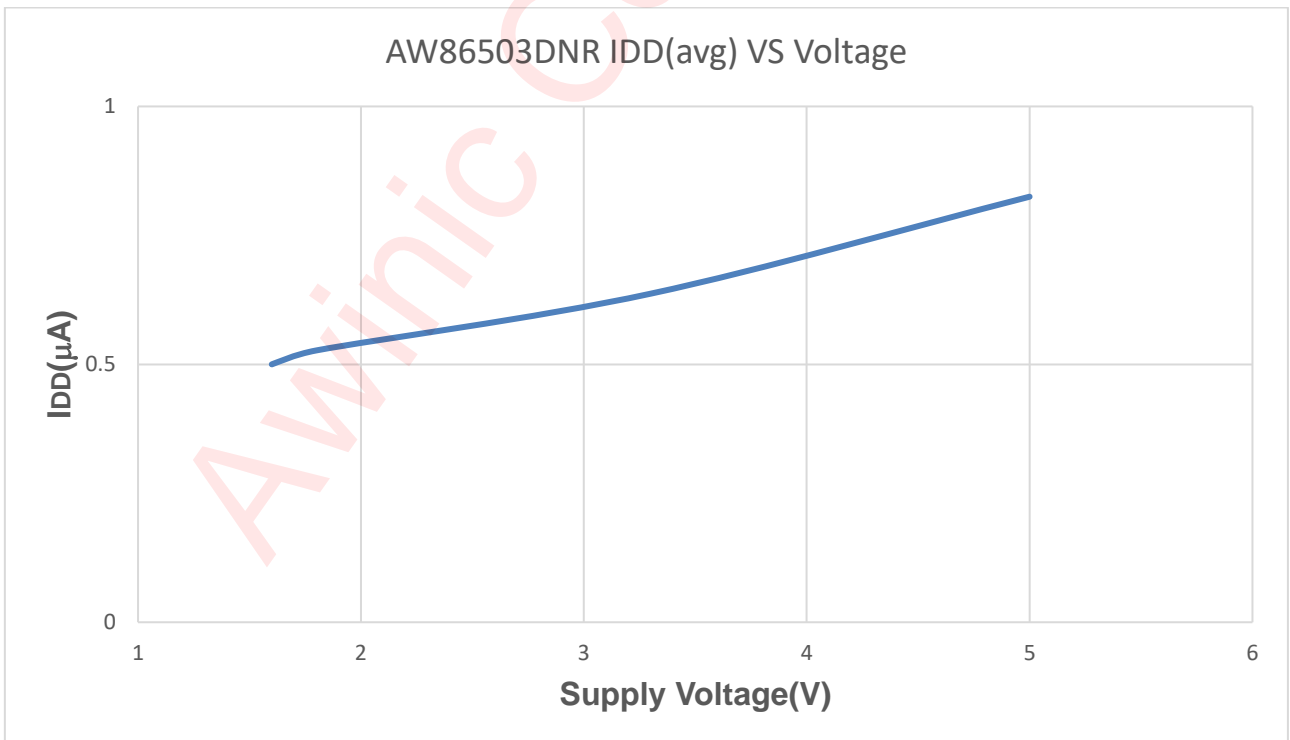

Average Supply Current vs. Supply Voltage(Ta=27°C)

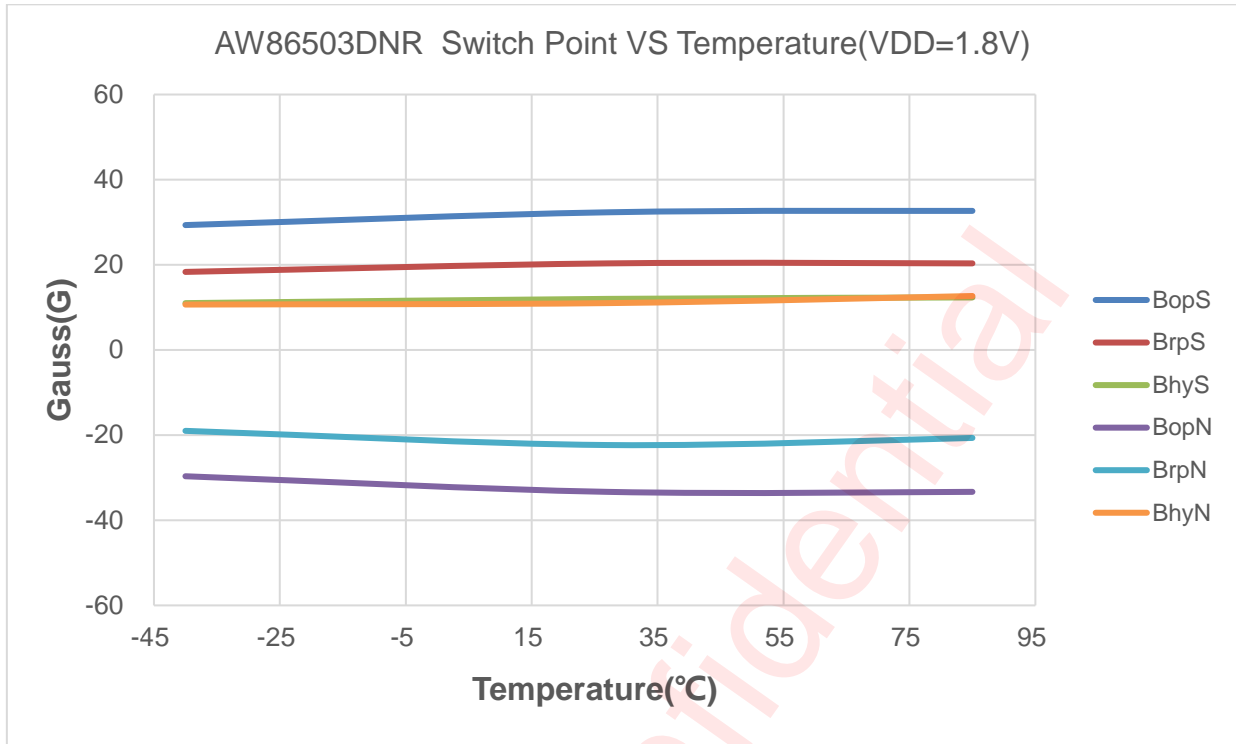

Ambient Temperature Ta[°C]
Bop,Brp vs. Ta(V_{DD}=1.8V)

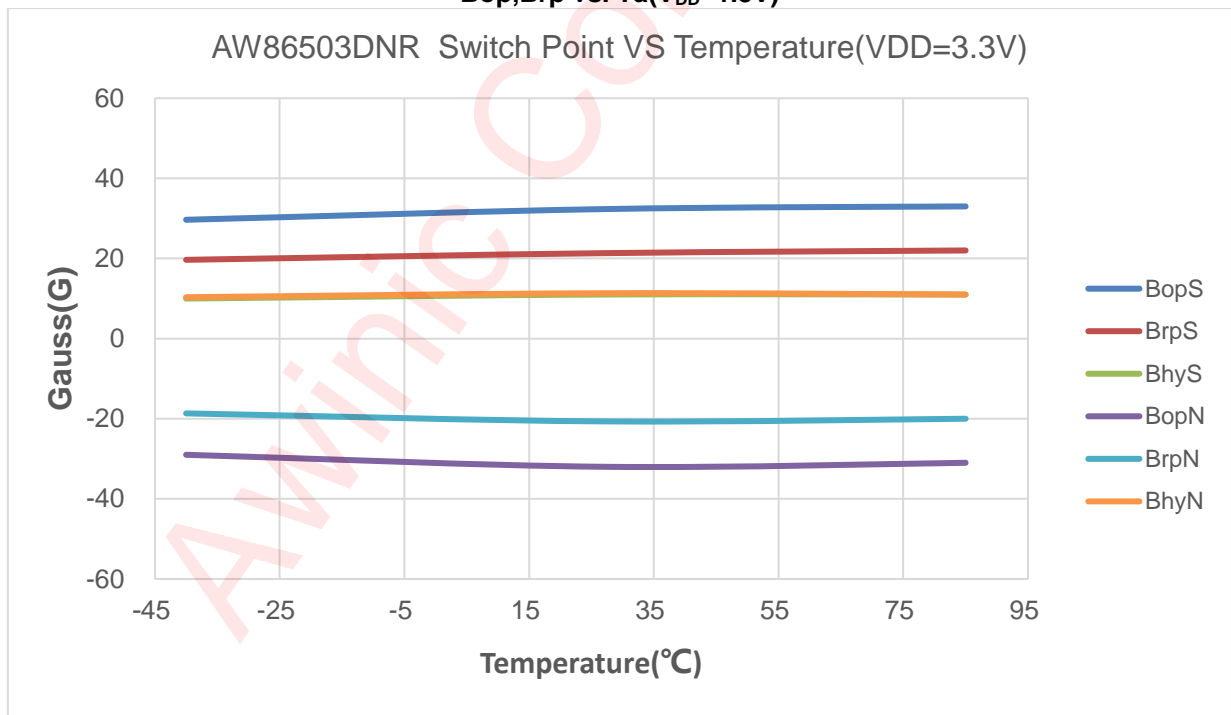

Ambient Temperature Ta[°C]
Bop,Brp vs. Ta(V_{DD}=3.3V)

Figure 5 The Typical Characteristics of AW86503DNR

Application Information

It is recommended to connect an external capacitor of $0.1\mu\text{F}$ to VDD and GND. The noise of the injection device can be reduced.



Figure 6 The Application Circuit of AW86503DNR

Tape And Reel Information

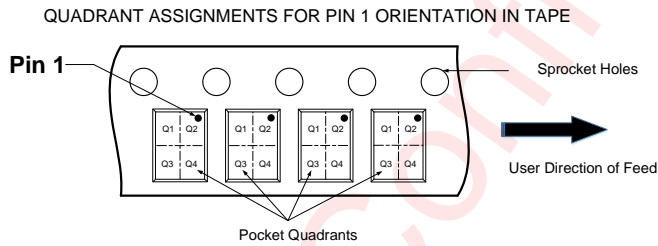
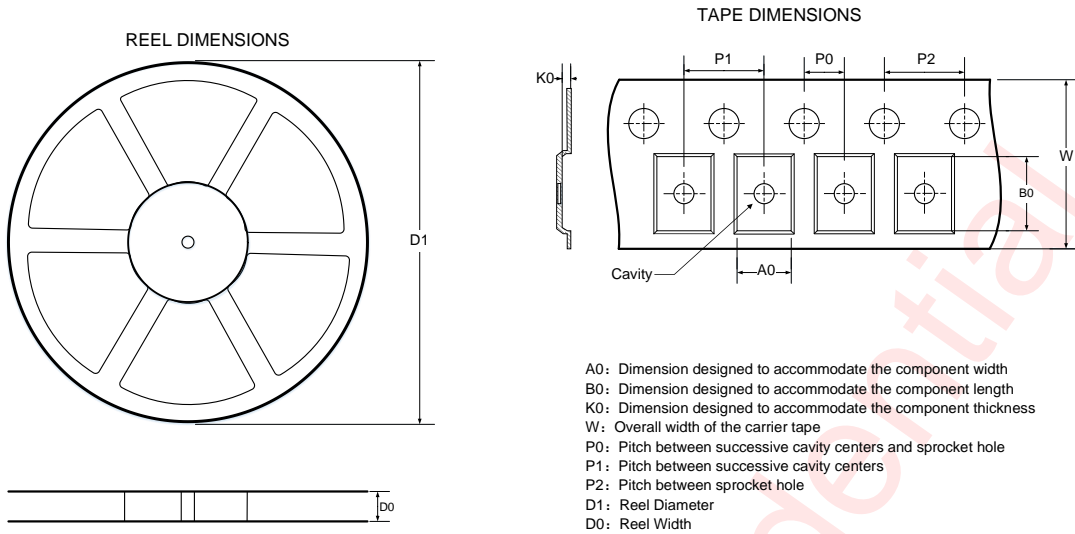

Note: The above picture is for reference only. Please refer to the value in the table below for the actual size

DIMENSIONS AND PIN1 ORIENTATION

D1 (mm)	D0 (mm)	A0 (mm)	B0 (mm)	K0 (mm)	P0 (mm)	P1 (mm)	P2 (mm)	W (mm)	Pin1 Quadrant
178	8.4	1.6	1.3	0.5	2	4	4	8	Q2

All dimensions are nominal

Package Description

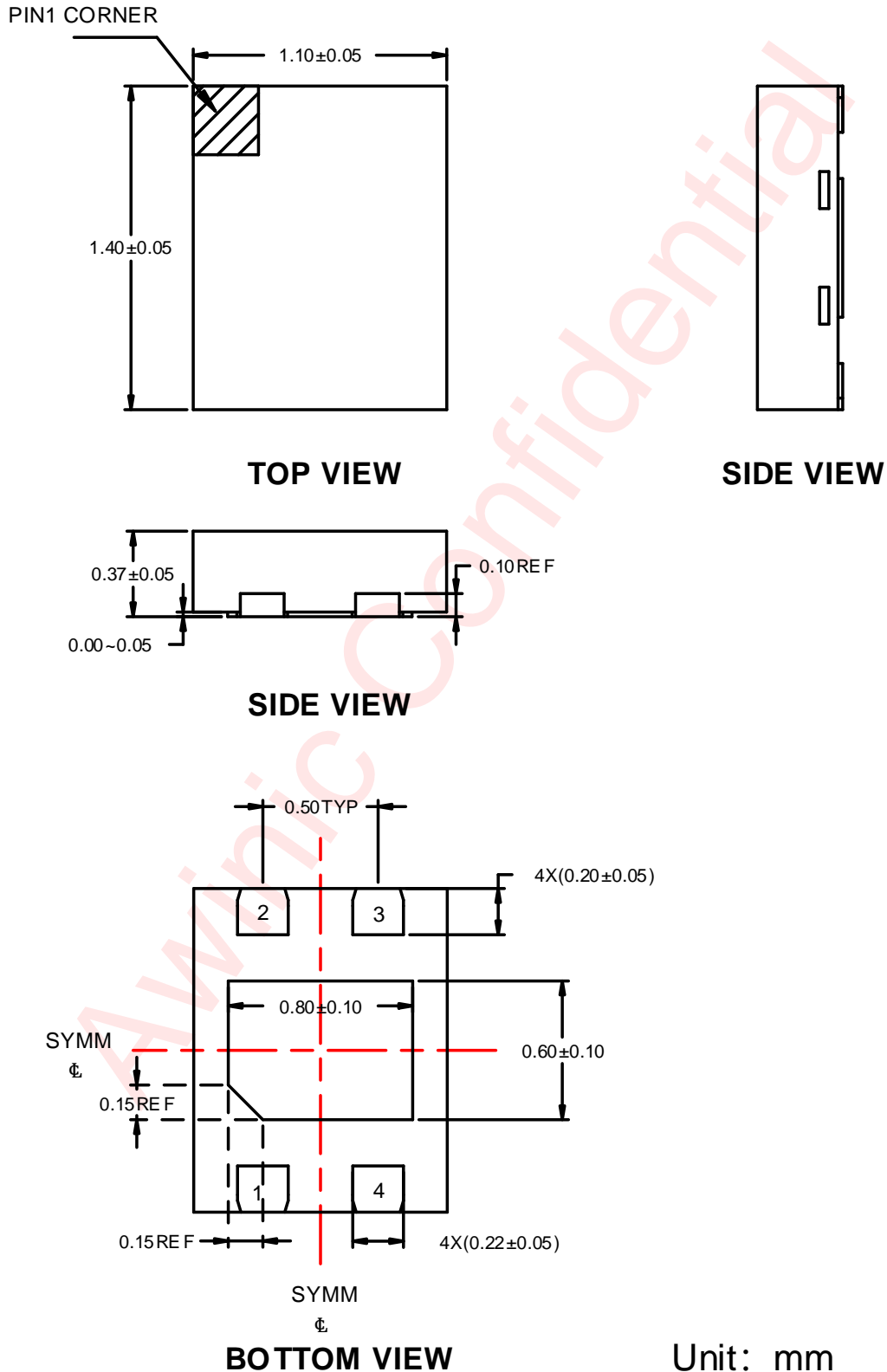

Land Pattern Data

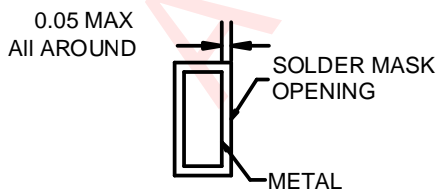
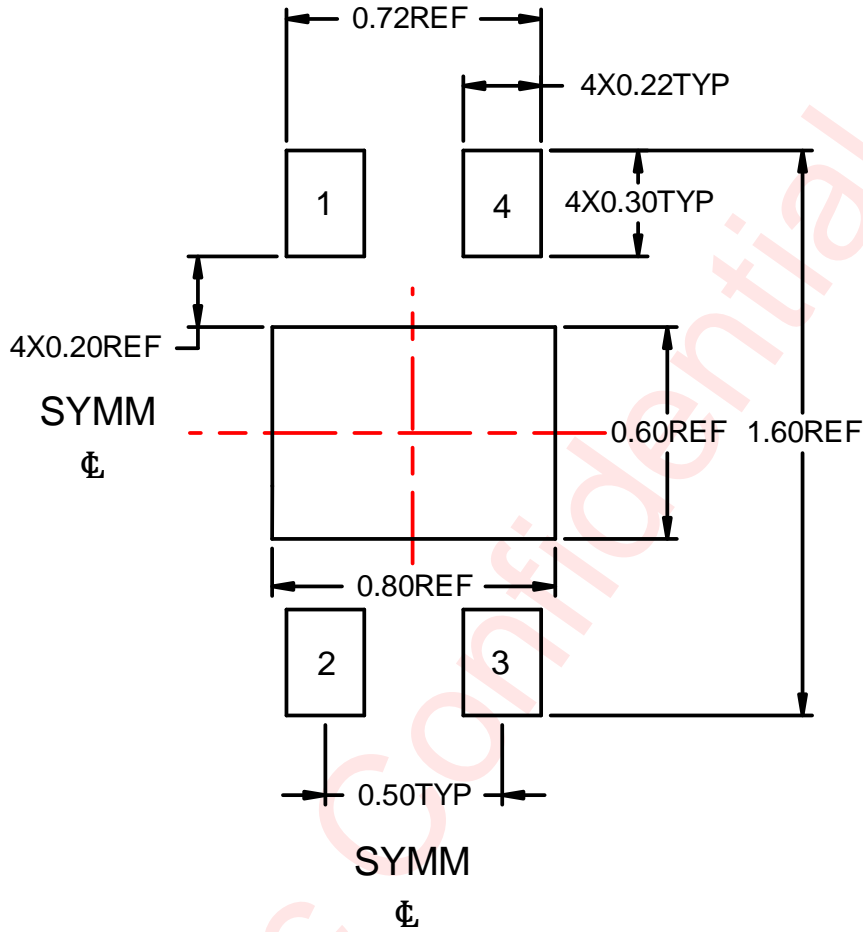

NON SOLDER MASK DEFINED

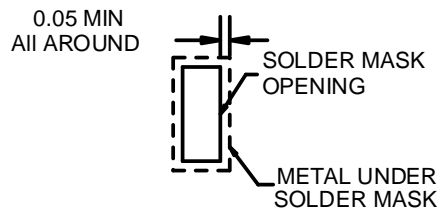

SOLDER MASK DEFINED

Unit: mm

Revision History

Version	Date	Change Record
V1.0	Apr. 2021	Officially initial version.
V1.1	Sep. 2021	Revise current value from 0.55 μ A to 0.7 μ A When $V_{DD}=3.3V$.
V1.2	Mar. 2022	Temperature range of magnetic parameters.
V1.3	Jul. 2022	Chart temperature changed from -20°C to -40°C.
V1.4	May.2024	The maximum Bop value has been changed from $\pm 39Gs$ to $\pm 40Gs$.
V1.5	Mar. 2025	Modify the Functional Block Diagram

Awinic Confidential

Disclaimer

All trademarks are the property of their respective owners. Information in this document is believed to be accurate and reliable. However, Shanghai AWINIC Technology Co., Ltd (AWINIC Technology) does not give any representations or warranties, expressed or implied, as to the accuracy or completeness of such information and shall have no liability for the consequences of use of such information.

AWINIC Technology reserves the right to make changes to information published in this document, including without limitation specifications and product descriptions, at any time and without notice. Customers shall obtain the latest relevant information before placing orders and shall verify that such information is current and complete. This document supersedes and replaces all information supplied prior to the publication hereof.

AWINIC Technology products are not designed, authorized or warranted to be suitable for use in medical, military, aircraft, space or life support equipment, nor in applications where failure or malfunction of an AWINIC Technology product can reasonably be expected to result in personal injury, death or severe property or environmental damage. AWINIC Technology accepts no liability for inclusion and/or use of AWINIC Technology products in such equipment or applications and therefore such inclusion and/or use is at the customer's own risk.

Applications that are described herein for any of these products are for illustrative purposes only. AWINIC Technology makes no representation or warranty that such applications will be suitable for the specified use without further testing or modification.

All products are sold subject to the general terms and conditions of commercial sale supplied at the time of order acknowledgement.

Nothing in this document may be interpreted or construed as an offer to sell products that is open for acceptance or the grant, conveyance or implication of any license under any copyrights, patents or other industrial or intellectual property rights.

Reproduction of AWINIC information in AWINIC data books or data sheets is permissible only if reproduction is without alteration and is accompanied by all associated warranties, conditions, limitations, and notices. AWINIC is not responsible or liable for such altered documentation. Information of third parties may be subject to additional restrictions.

Resale of AWINIC components or services with statements different from or beyond the parameters stated by AWINIC for that component or service voids all express and any implied warranties for the associated AWINIC component or service and is an unfair and deceptive business practice. AWINIC is not responsible or liable for any such statements.