

Main technical indicators(主要技术指标)	
1.Mating (插拔次数)	5000
2.Working Temperature (温度)	-55~+150 °C
3.IP Rating (防护级别)	IP 54
4.Diameter of socket end(插合端直径)	φ0.7
5.Testing Voltage (测试电压)	850V
6.Working Voltage (工作电压)	1200V
7.Rated Current (额定电流)	5A
8.Shell material(壳体材质)	Brass (chromium plating) shell and chuck nut/( nickel plating) pin sleeve and middleware/黄铜（镀铬）外壳和夹头螺母/（镀镍）插销套和中间件
9.Pin Material(插针材料)	Copper alloy gold plating(铜合金镀金)
10.Insulator material(绝缘体材质)	L:PPS P:PEEK

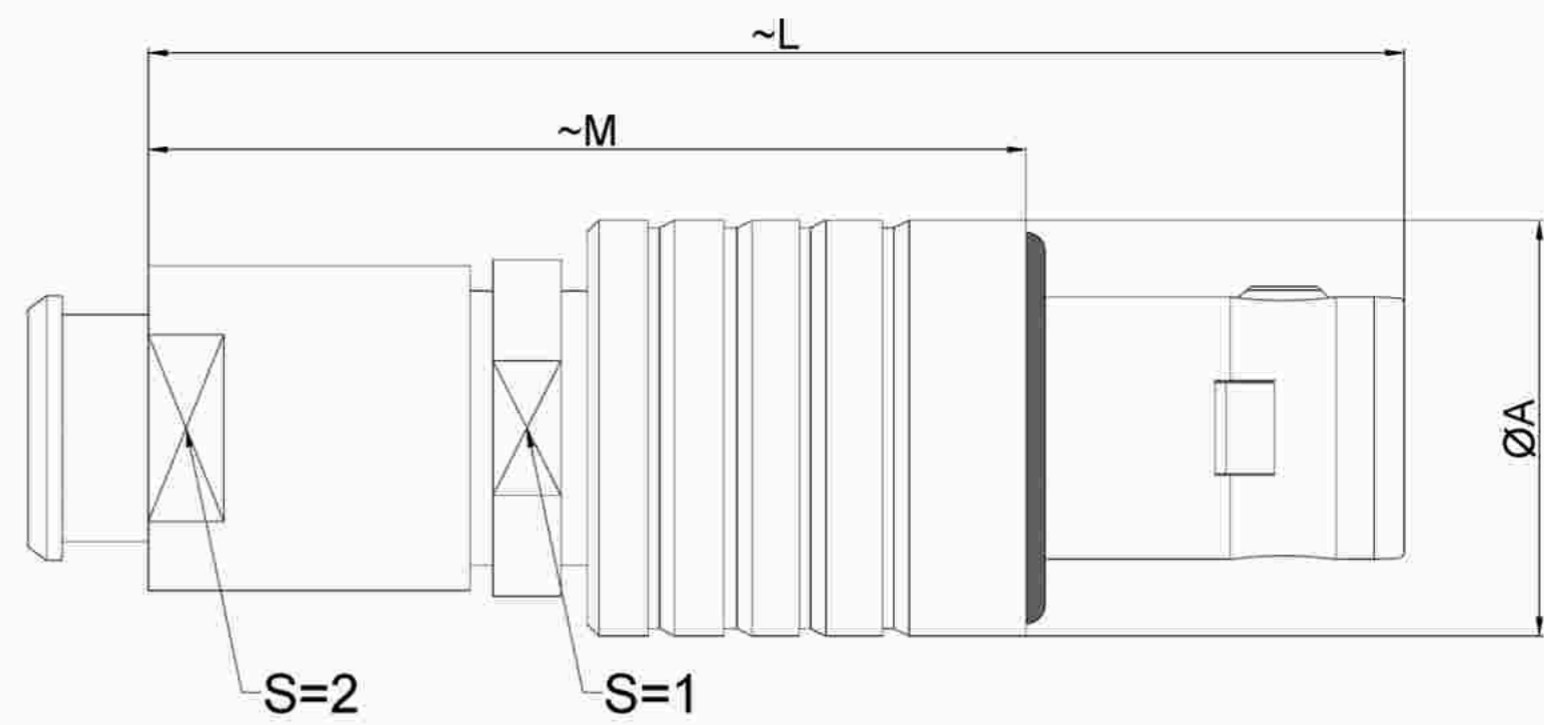

	A	L	M	S1	S2
MM	φ16.5	48	36	13.0	12
in	0.6496	1.8898	1.4173	0.512	0.4725

Sum up(总结)	
Series(系列)	B
Shell style/model (外壳样式/型号)	TEG: Straight plug, cable collet, front seal and nut for fitting a bend relief (IP 54 when mated) 直塞、电缆夹头、前密封件和用于安装弯曲凸起（配对时IP54）
Button (按键)	A button(一个按键)
Termination type (终止类型)	Male solder(公焊锡)
Line diameter awg(线材直径)	30-22AWG
Cable diameterφ (电缆直径)	φ8.3-9.2MM
Matching parts(配件)	ZGG.2B.P19.CXL

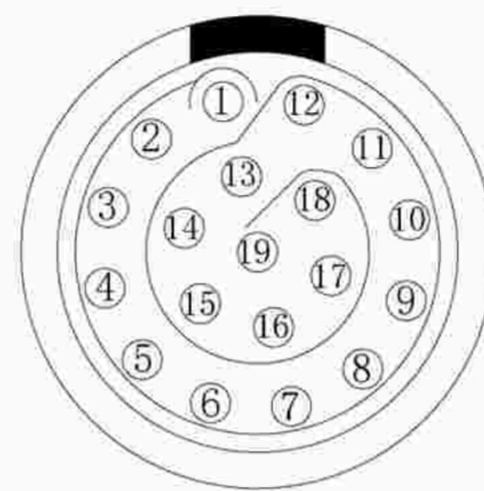

Welded surface  
(焊接面)

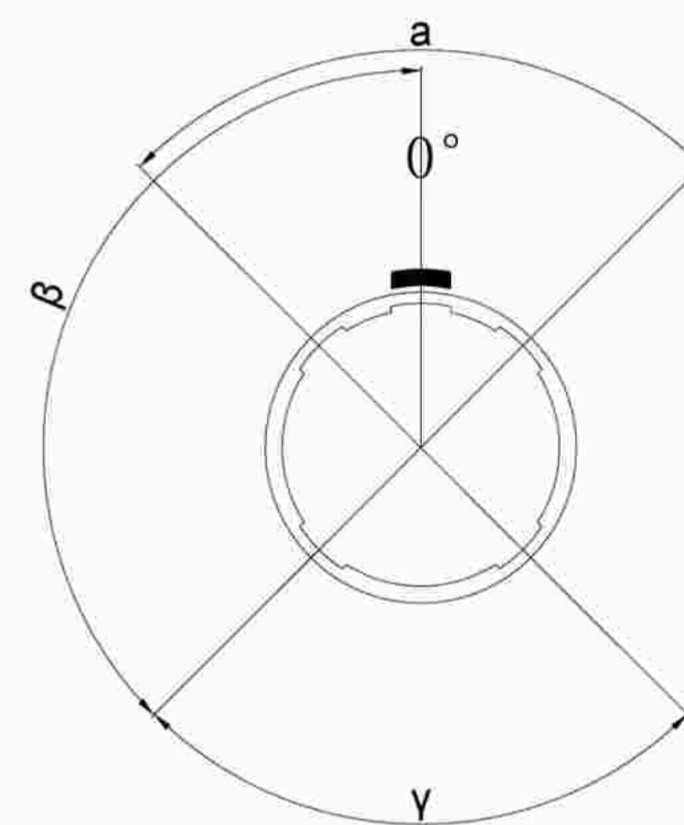

Positive view  
(正视图)

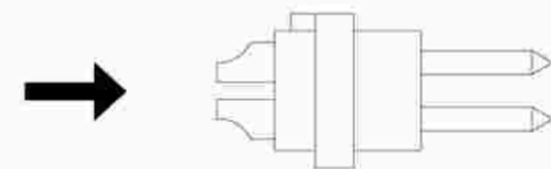

Solder core  
(焊接型公胶芯)

Location pin combination(定位销组合)			
(编号) Number	Number of positioning pins(定 位销数量)	Angle( 角度)	Series(系列)--2B
G	One(1)		(Zero degrees)0°
A	Two(2)	A	Thirty degrees(30°)
B	Two(2)		Forty-five degrees(45°)
C	Two(2)		Sixty degrees(60°)
D	Two(2)	γ	95 degrees (95°)
E	Two(2)	β	120 degrees(120°)
F	Two(2)		145 degrees(145°)
J	Two(2)	A	37.5degrees(37.5°)
K	Two(2)		52.5degrees(52.5°)
L	Two(2)		γ

	A	B	C√	ANGLE	
5-10	±0.02	±0.05	±0.1	0°-30°	±0.1°
50-100	±0.1	±0.15	±0.2	61°-90°	±0.5°
50-100	±0.15	±0.2	±0.25		
100-	±0.15%	±0.20%	±0.25%		

TE G. 2B. P19.C X A D 92 H

- Model(型号)
- Positioning pin(定位销)
- Series(系列)
- Needle core configuration(针芯配置)
- Outer casing(外壳)
- Insulator(绝缘体)
- Needle core(针芯)
- Type of CXamp(线夹类型)
- Cable diameter(电缆直径)
- SH means a sheath type, not a cover type.  
(H表示护套型, 不表示为不带护套型)

DESIGNED(设计)  
广东星坤科技股份有限公司  
CHECKED(校对)

APPROVED(审核)  
日期

REVISIONS

文件工程章

www.helloxkb.com www.helloxkb.cn

DATE(日期)	SCALE(比例)	N/A(不适用)
DATE(日期)	VIEW(视图)	
DATE(日期)	UNIT(单位)	MM
	MATERIAL (材料)	

MODEL TYPE	型号类型: TEG.2B.P19.CXAD92H
PART NO.	2B19-core plug
名称:	2B19芯插头
DWG NO.:	
WEIGHT(重量)	SHEET(表)
	REVISION(修订)
	1/1
	A0