

7	8	9
标记 MARK	ECN编号/变更内容 ECN NO/DEFINITION	修改 REVISE
		日期 DATE
		核准 APPROVE

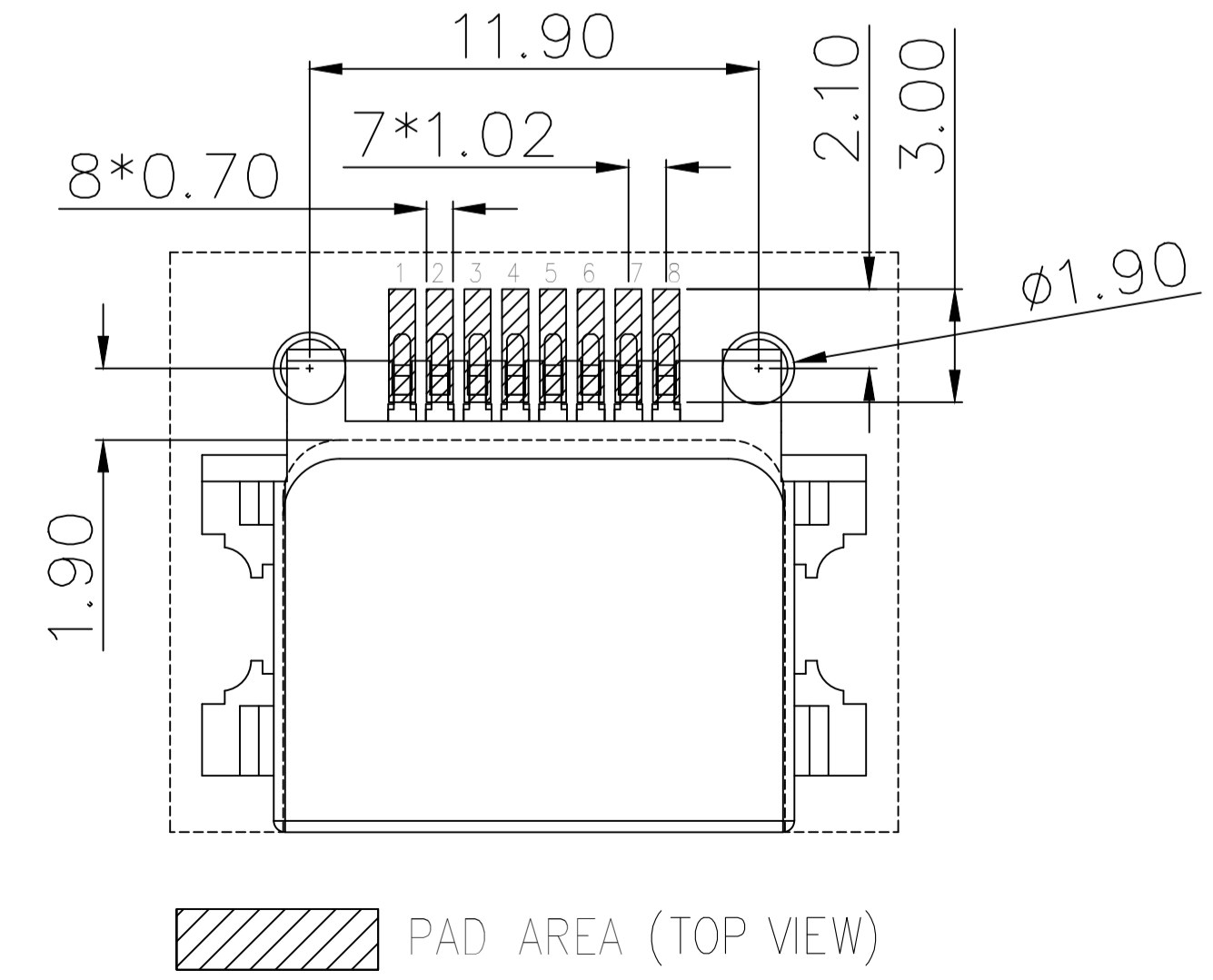
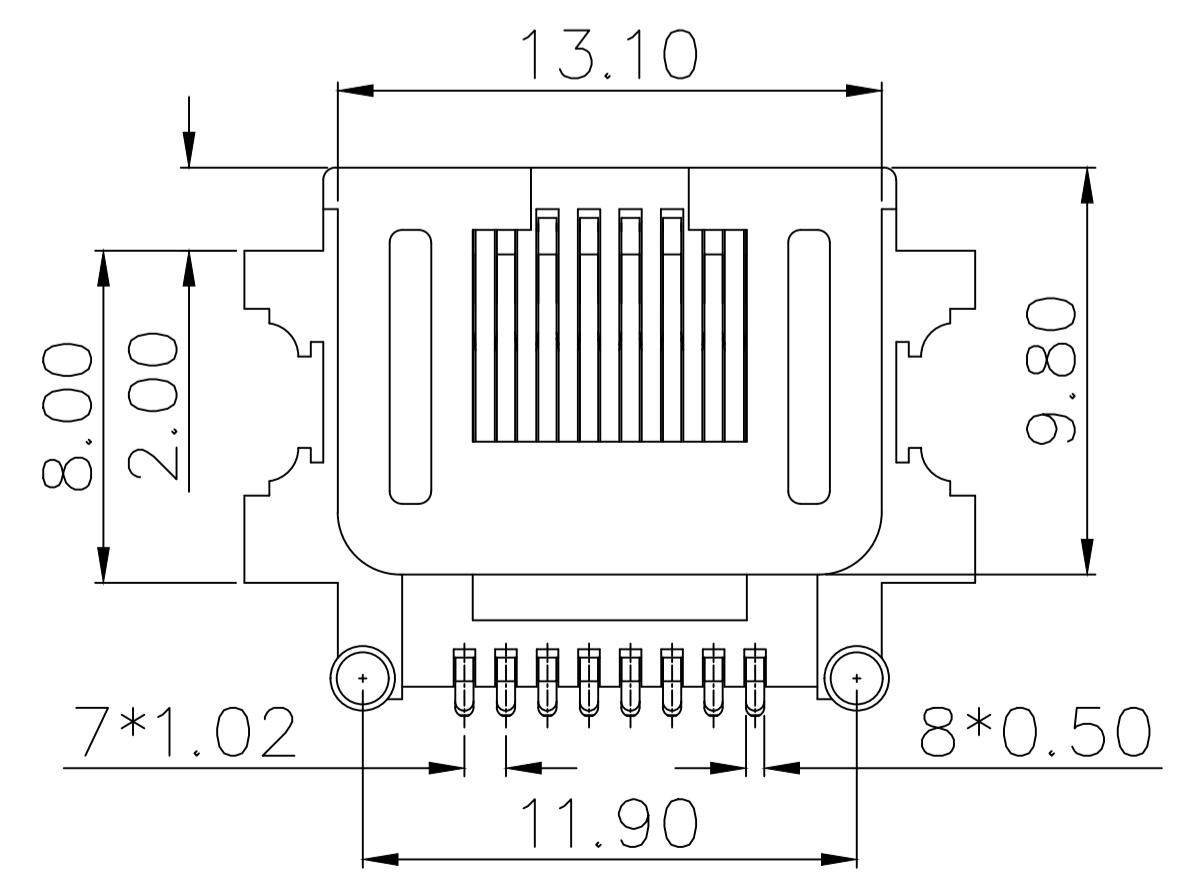
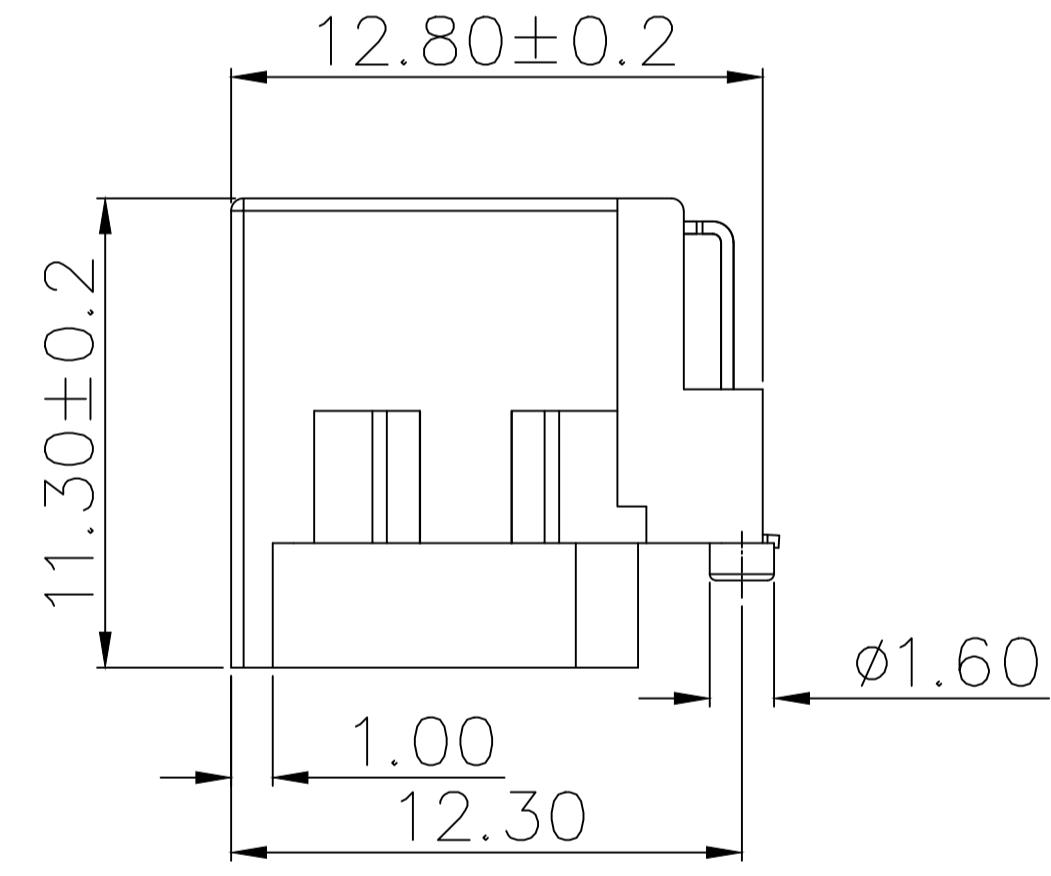
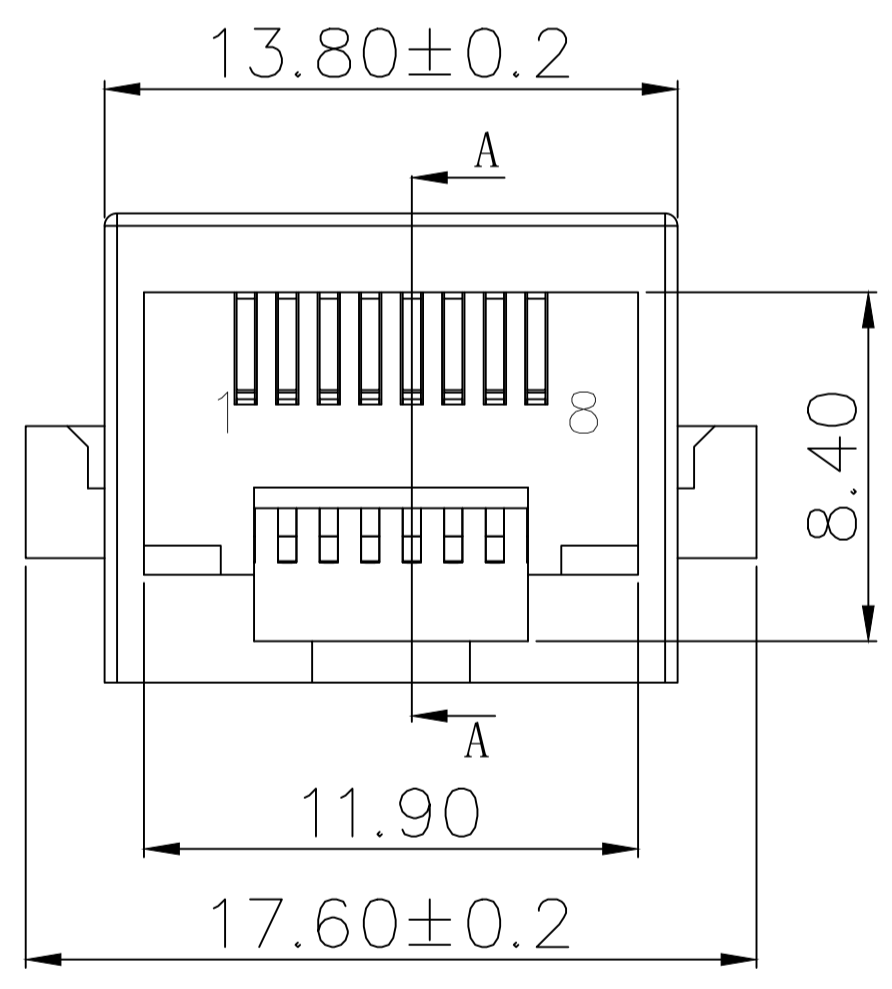
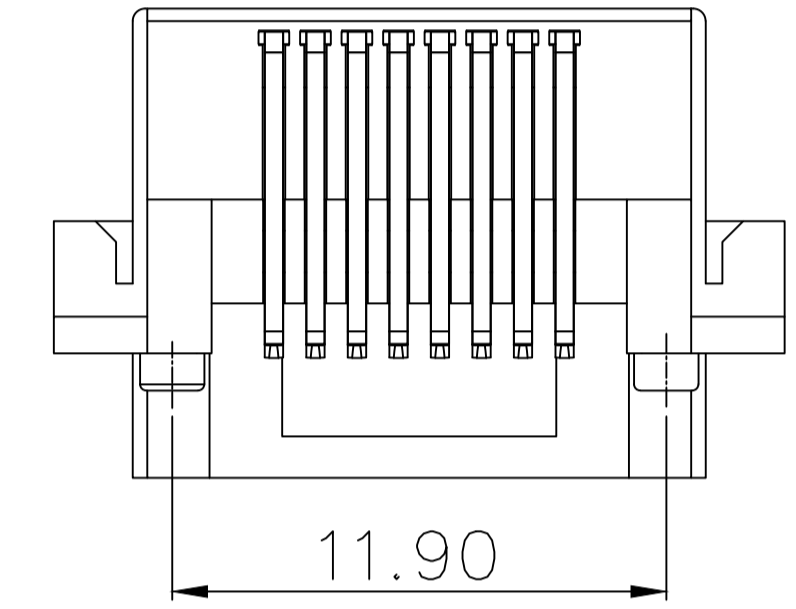
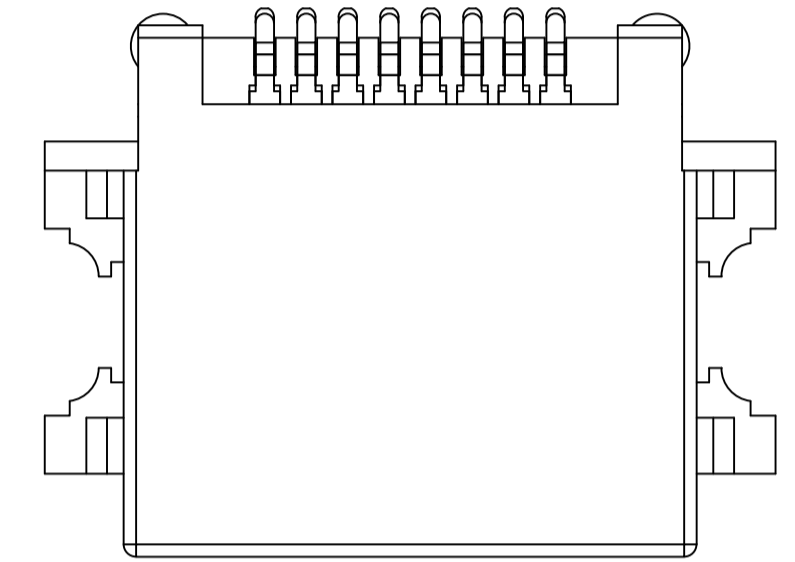
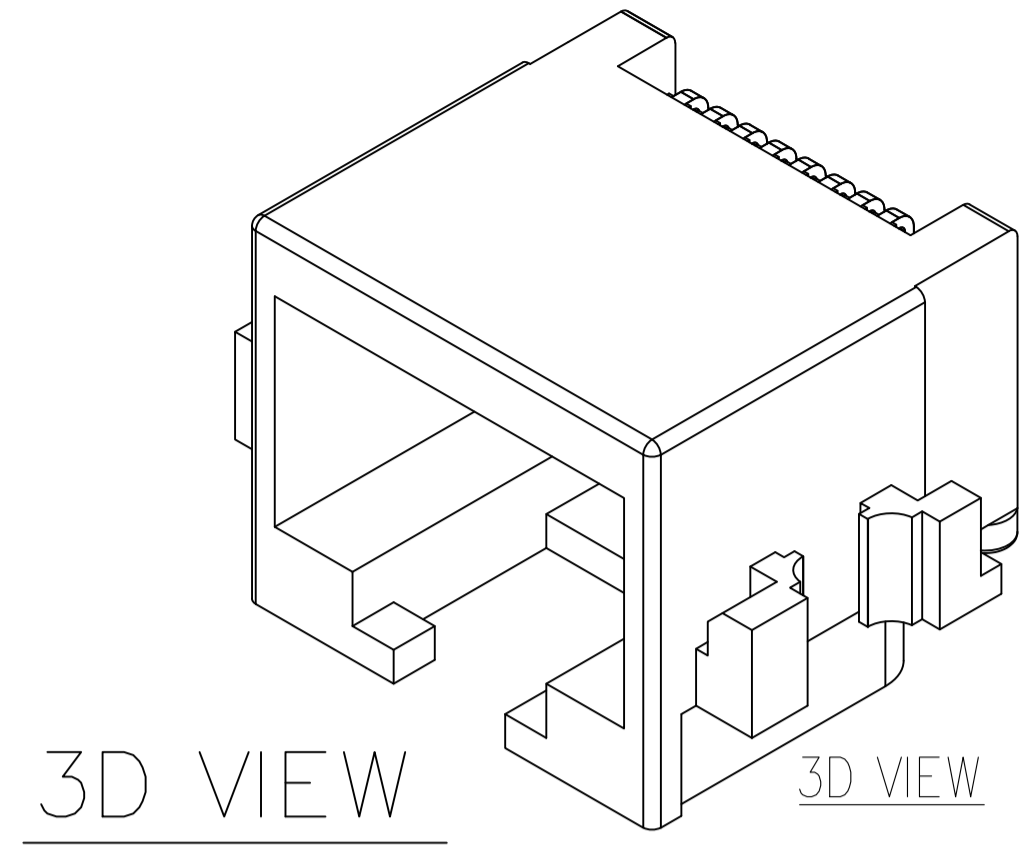
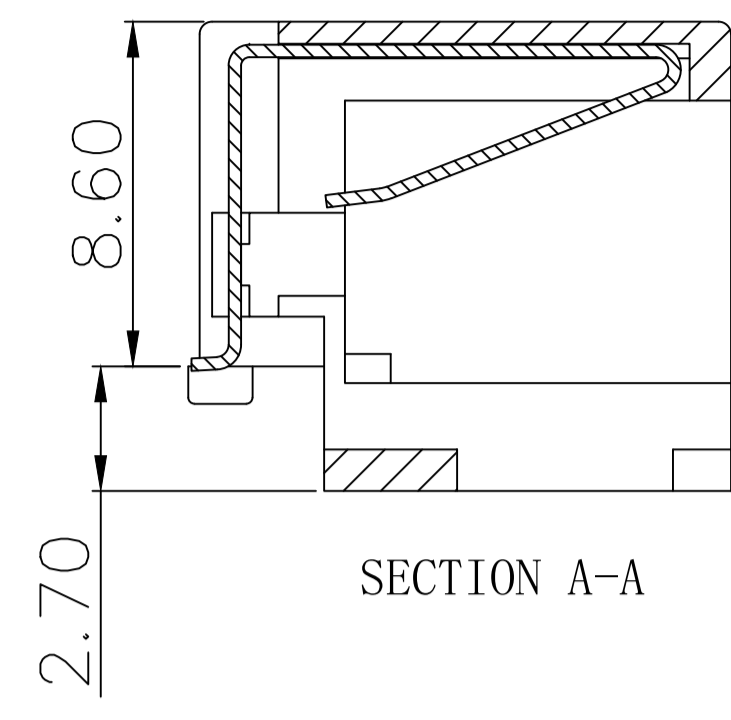

NOTES:

1. MATERIAL:
 - 1.1. HOUSING: LCP ,COLOR IS BLACK;
 - 1.2. CONTACT: PHOSPHOR COPPER (C5191 T=0.30mm);
2. FINISH: GOLD PLATED G/Fu";
4. ELECTRICAL:
 - 4.1. VOLTAGE RATING: 125 VAC RMS;
 - 4.2. CURRENT RATING: 1.5 AMP;
 - 4.3. CONTACT RESISTANCE: 35MILLIOHMS MAX.;
 - 4.4. WITHSTAND VOLTAGE: 500 VAC RMS 50(60)Hz,1MIN.;
 - 4.5. INSULATION RESISTANCE: 500MEGOHMS MIN @500V DC.;
5. MECHANICAL:
 - 5.1. MATING/UNMATING FORCE: 22N MAX.;
 - 5.2. RETENTIION STRENGTH: 50N MIN.;
 - 5.3. OPERATING LIFE: 750 CYCLES MIN.;
6. ENVIRONMENTAL:
 - 6.1. STORAGE TEMPERATURE RANGE: -40°C~+85°C;
 - 6.2. OPERATION TEMPERATURE RANGE: -25°C~+70°C;
- 7.SALT SPRAY TEST: 8H(EXCLUDING RIVETED BENDS)

2	接触	铜	镀金G/F	
1	底座	LCP	黑色	
序号	品名	材质	电镀/颜色	备注



深圳市虹成电子有限公司

品名 TITLE	网口
料号 PART NO	HC-WK88-H865T-QS

UNLESS GENERAL TOLERANCE:	OTHERWISE, TOLERANCE:	比列 SCALE	1:1		
X.xxx ±0.10	X.xx ±0.20	单位 UNIT	MM	制图 DRAW	AhYe
X.x ±0.30		张数 PART NO	1 OF 1	审核 CHECKED	夏操云
ANGULAR:		版本 REV	A	批准 APPROVE	赵亮亮
X.xx° ±1°					
X.x° ±3°					
X.° ±5°					

