

100V N-Channel Power MOSFET

Description

MPT030N10P, the N-channel Enhanced Power MOSFETs, is obtained by advanced double trench technology which reduce the conduction loss, improve switching performance and enhance the avalanche energy. This is suitable device for BMS and high current switching applications.

General Features

- ① $V_{DS}=100V$, $R_{dson}<3m\Omega$ @ $V_{GS}=10V$, $I_D=180A$ (Typ: $2.5m\Omega$)
- ② Fast Switching
- ③ Low On-Resistance
- ④ Low Gate Charge
- ⑤ Low Reverse transfer capacitances
- ⑥ High avalanche ruggedness
- ⑦ RoHS product

Application

- ① BMS
- ② High current switching applications

Package Marking And Ordering Information:

Ordering Codes	Package	Product Code	Packing
MPT030N10-P	TO-220	MPT030N10P	Tube

ABSOLUTE RATINGS at TC=25°C, unless otherwise specified

Symbol	Parameter	Rating	Units
V_{DSS}	Drain-Source Voltage	100	V
I_D	Continuous Drain Current, Silicon Limited	200	A
	Continuous Drain Current, Package Limited	180	A
	Continuous Drain Current @ $T_C=100^\circ C$, Silicon Limited	126.6	A
I_{DM} ^{Note1}	Pulsed Drain Current	720	A
V_{GS}	Gate-Source Voltage	± 20	V
E_{AS} ^{Note2}	Avalanche Energy	784	mJ
P_D	Power Dissipation	250	W
	Derating Factor above 25°C	2	W/°C
T_J, T_{stg}	Operating Junction and Storage Temperature Range	150, -55 to 150	°C
T_L	Maximum Temperature for Soldering	260	°C

Note1: Repetitive Rating: Pulse width limited by maximum junction temperature

Note2: $L=0.5mH$, $I_{as}=35A$, Start $T_J=25^\circ C$

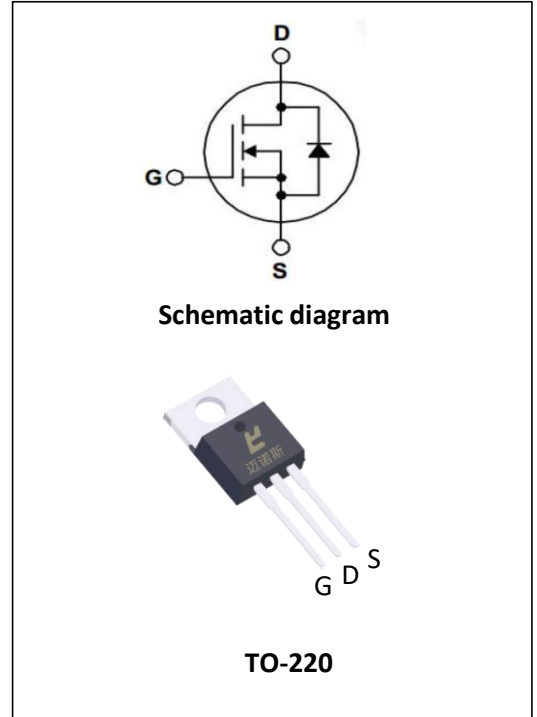

Thermal characteristics

Symbol	Parameter	Max	Units
R _{θJC}	thermal resistance, Junction-Case	0.5	°C/W
R _{θJA}	thermal resistance, Junction-Ambient	62.5	°C/W

Electrical Characteristics at T_c=25°C, unless otherwise specified

OFF Characteristics						
Symbol	Parameter	Test Conditions	Values			Units
			Min	Typ	Max	
V _{DSS}	Drain-Source Breakdown Voltage	V _{GS} =0V, I _D =250μA	100	110	--	V
I _{DSS}	Drain-Source Leakage Current	V _{DS} =100V, V _{GS} =0V	--	--	1	μA
		V _{DS} =80V, V _{GS} =0V @T _c =125°C	--	--	100	μA
I _{GSS(F)}	Gate-Source Forward Leakage	V _{GS} =+20V	--	--	100	nA
I _{GSS(R)}	Gate-Source Reverse Leakage	V _{GS} =-20V	--	--	-100	nA

ON Characteristics						
Symbol	Parameter	Test Conditions	Values			Units
			Min	Typ	Max	
R _{DS(on)}	Drain-Source On-Resistance	V _{GS} =10V, I _D =50A	--	2.5	3	mΩ
V _{GS(th)}	Gate Threshold Voltage	V _{DS} =V _{GS} , I _D =250μA	2.0	3.0	4.0	V
Pulse width tp≤300μs, δ≤2%						

Dynamic Characteristics						
Symbol	Parameter	Test Conditions	Values			Units
			Min	Typ	Max	
C _{iss}	Input Capacitance	V _{DS} =50V, V _{GS} =0V, f=1MHz	--	9200	--	pF
C _{OSS}	Output Capacitance		--	1130	--	
C _{rSS}	Reverse Transfer Capacitance		--	110	--	
Q _g	Total Gate Charge	V _{DD} =50V, I _D =92.5A, V _{GS} =10V	--	131	--	nC
Q _{gs}	Gate-Source charge		--	50	--	
Q _{gd}	Gate-Drain charge		--	24.5	--	

Switching Characteristics

Symbol	Parameter	Test Conditions	Values			Units
			Min	Typ	Max	
$t_{d(on)}$	Turn-On Delay Time	VDD=50V, VGS=10V, RG=1.6Ω, Resistive Load	--	32	--	ns
t_r	Rise Time		--	40	--	
$t_{d(off)}$	Turn-Off Delay Time		--	80	--	
t_f	Fall Time		--	35	--	

Source-Drain Diode Characteristics

Symbol	Parameter	Test Conditions	Values			Units
			Min	Typ	Max	
I_S	Continuous Source Current		--	--	180	A
I_{SM}	Maximum Pulsed Current		--	--	720	A
V_{SD}	Diode Forward Voltage	$V_{GS}=0V, I_S=50A$	--	--	1.2	V
T_{rr}	Reverse Recovery Time	$I_S=92.5A,$ $di/dt=100A/us$	--	80	--	ns
Q_{rr}	Reverse Recovery Charge		--	195	--	uC

Characteristics Curves

Figure 1. Safe Operating Area

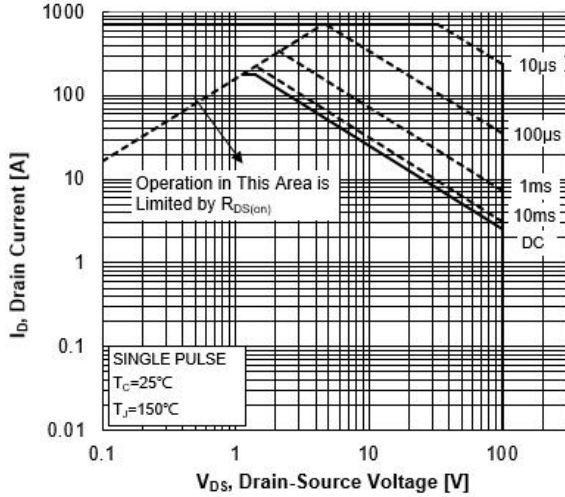

Figure 2. Maximum Power Dissipation vs Case Temperature

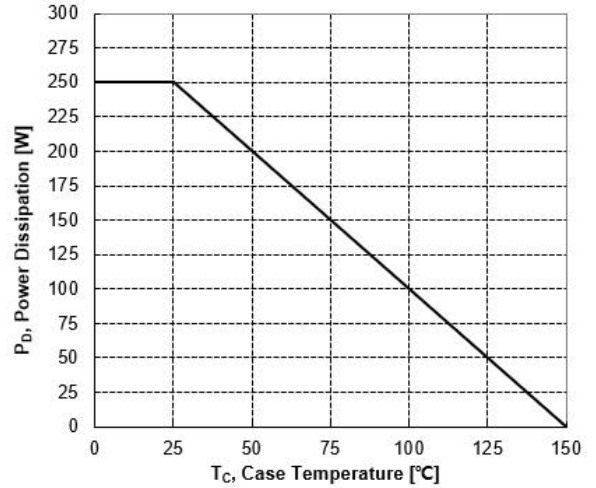

Figure 3. Maximum Continuous Drain Current vs Case Temperature

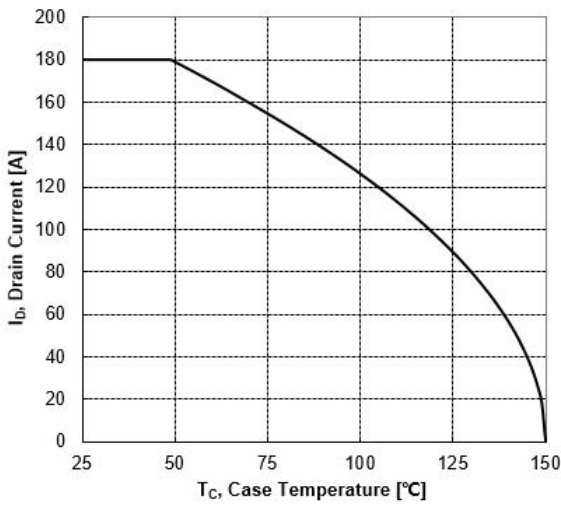

Figure 4. Typical Output Characteristics

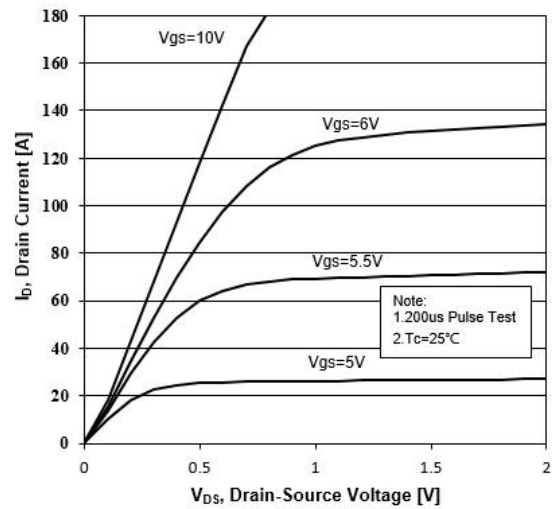

Figure 5. Transient Thermal Impedance

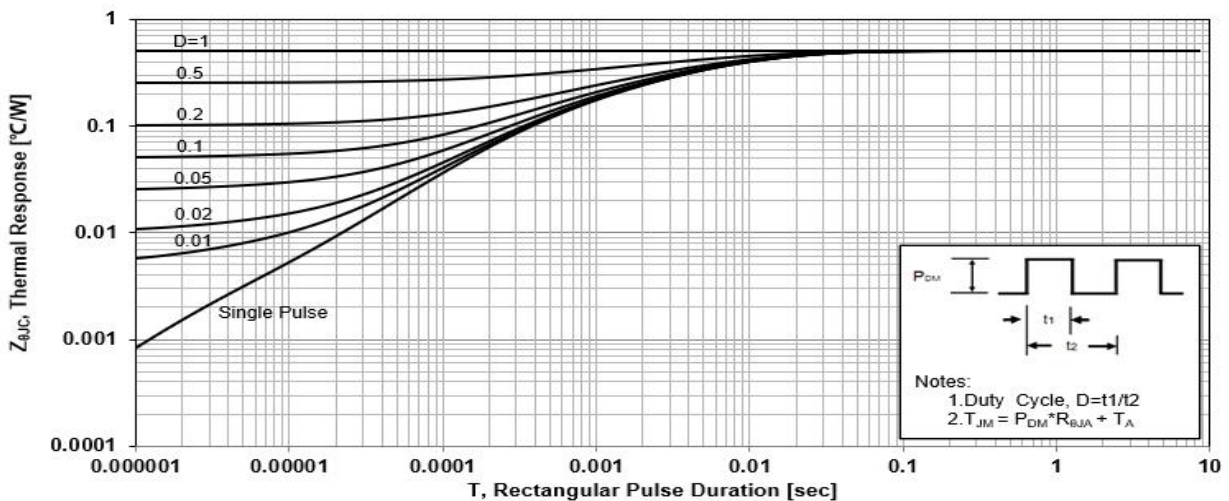

Figure 6. Typical Transfer Characteristics

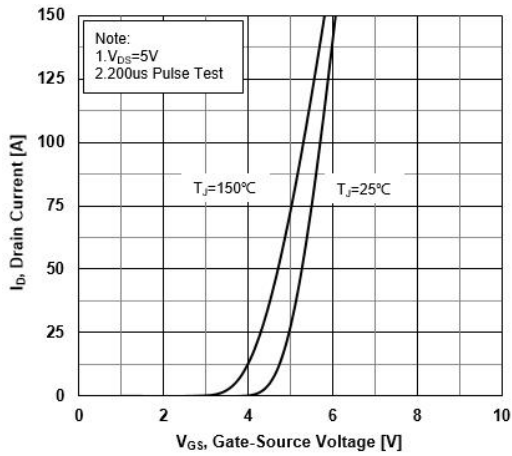

Figure 7. Source-Drain Diode Forward Characteristics

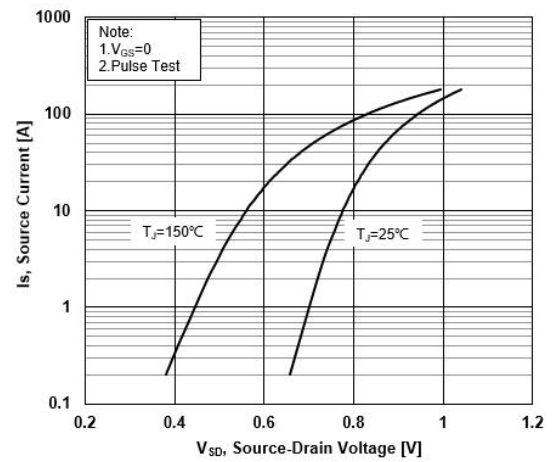

Figure 8. Drain-Source On-Resistance vs Drain Current

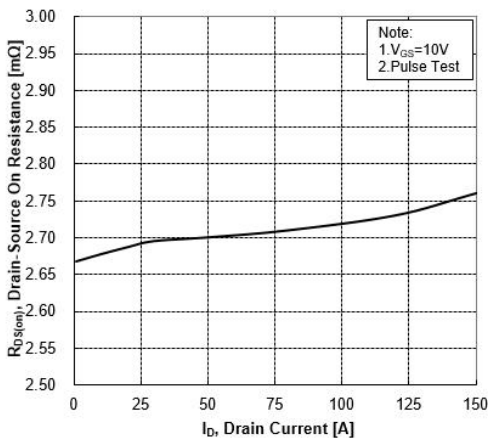

Figure 9. Normalized On-Resistance vs Junction Temperature

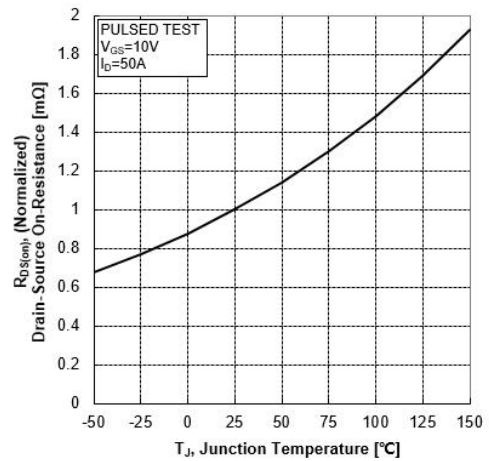

Figure 10. Normalized Threshold Voltage vs Junction Temperature

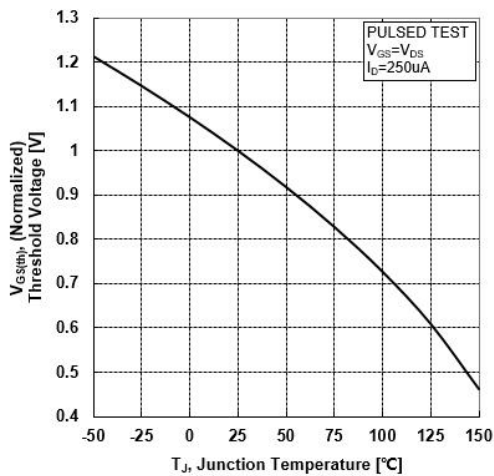

Figure 11. Normalized Breakdown Voltage vs Junction Temperature

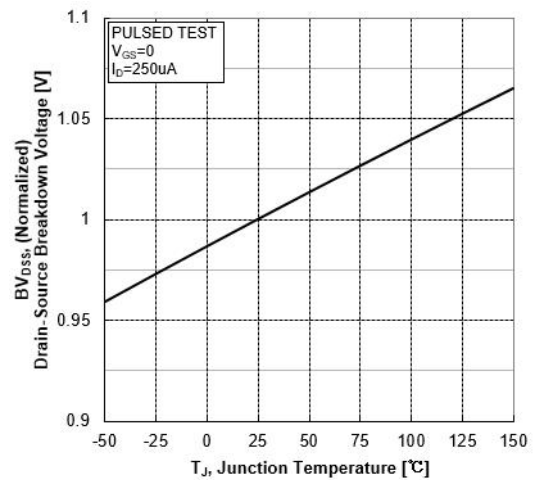

Figure 12. Capacitance Characteristics

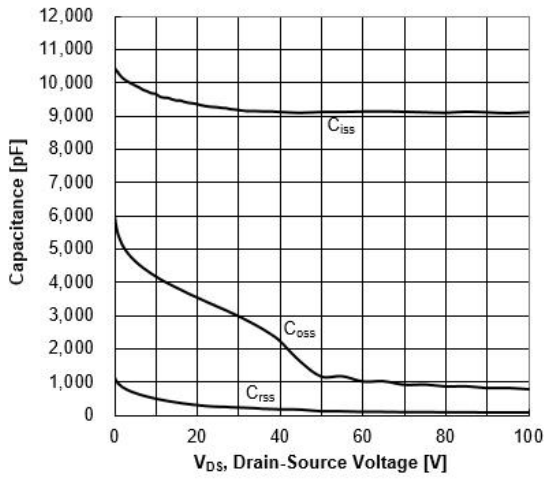
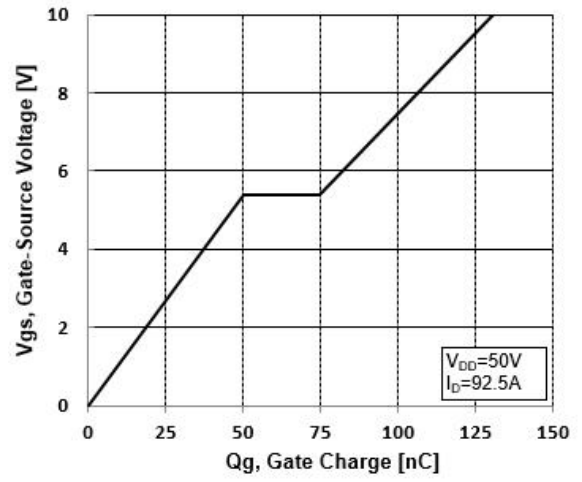

Figure 13. Typical Gate Charge vs Gate-Source Voltage



Test Circuit and Waveform

Figure 14. Resistive Switching Test Circuit

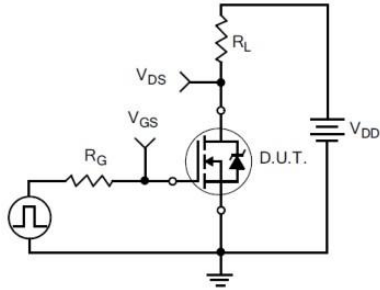

Figure 15. Resistive Switching Waveforms

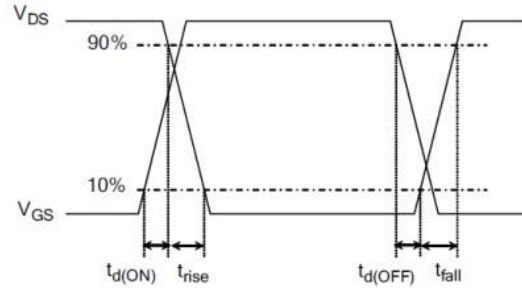

Figure 16. Gate Charge Test Circuit

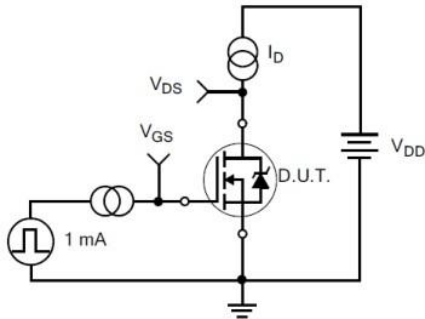

Figure 17. Gate Charge Waveforms

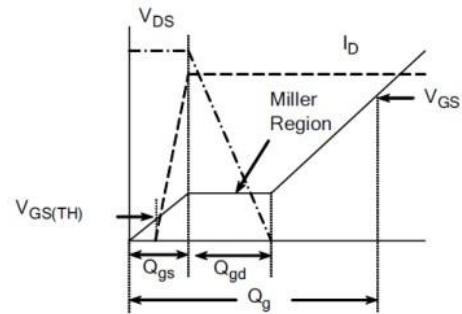

Figure 18. Diode Reverse Recovery Test Circuit

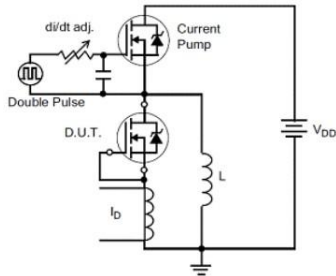

Figure 19. Diode Reverse Recovery Waveform

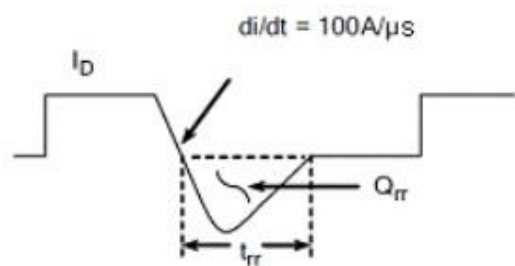

Figure 20. Unclamped Inductive Switching Test Circuit

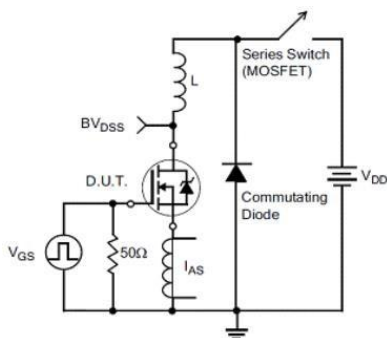
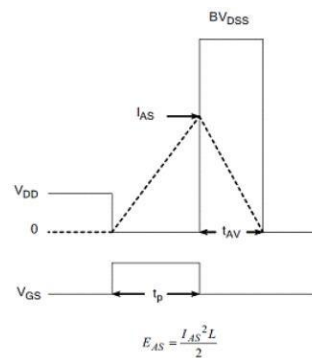
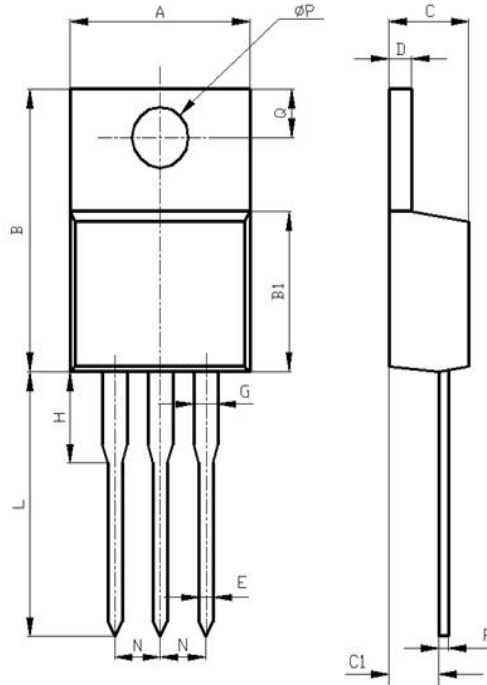

Figure 21. Unclamped Inductive Switching Waveform



Package Description



Items	Values(mm)	
	MIN	MAX
A	9.60	10.6
B	15.0	16.0
B1	8.90	9.50
C	4.30	4.80
C1	2.30	3.10
D	1.20	1.40
E	0.70	0.90
F	0.30	0.60
G	1.17	1.37
H	2.70	3.80
L	12.6	14.8
N	2.34	2.74
Q	2.40	3.00
φ P	3.50	3.90

TO-220 Package

NOTE:

1. Exceeding the maximum ratings of the device in performance may cause damage to the device, even the permanent failure, which may affect the dependability of the machine. Please do not exceed the absolute maximum ratings of the device when circuit designing.
2. When installing the heat sink, please pay attention to the torsional moment and the smoothness of the heat sink.
3. MOSFETs is the device which is sensitive to the static electricity, it is necessary to protect the device from being damaged by the static electricity when using it.
4. Shenzhen Minos reserves the right to make changes in this specification sheet and is subject to change without prior notice.

CONTACT:

深圳市迈诺斯科技有限公司（总部）

地址：深圳市福田区华富街道田面社区深南中路4026号田面城市大厦16D

邮编：518025

电话：0755-83273777