

BMF60N600C1

Super Junction Power MOSFET

600 V, 8 A, 600 mΩ



bestirpower

Description

BMF60N600C1 is power MOSFET using bestirpower's advanced super junction technology that can realize very low on-resistance and gate charge. It will provide much high efficiency by using optimized charge coupling technology. These user friendly devices give an advantage of Low EMI to designers as well as low switching loss.

Features

$V_{DS} @ T_{J,max}$	I_D	$R_{DS(on),max}$	$Q_{g,typ}$
650 V	8 A	600 mΩ	15 nC

- Extremely low losses due to very low FOM $R_{ds(on)} * Q_g$ and E_{oss} .
- Very high commutation ruggedness.

Applications

- PFC.
- SPWM.
- LCD TV.
- Lighting.
- UPS.

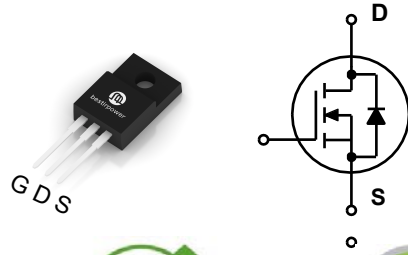

Absolute Maximum Ratings ($T_J = 25^\circ\text{C}$ unless otherwise noted)

Symbol	Parameter	Value	Unit
V_{DSS}	Drain to Source Voltage ¹⁾	600	V
V_{GSS}	Gate to Source Voltage	±30	V
I_D	Drain Current ²⁾	$V_{GS} = 10\text{ V}, (T_C = 25^\circ\text{C})$	8
		$V_{GS} = 10\text{ V}, (T_C = 100^\circ\text{C})$	5
I_{DM}	Drain Current	Pulsed	24
P_D	Power Dissipation		62.5
E_{AS}	Single Pulsed Avalanche Energy ³⁾		81
dv/dt	MOSFET dv/dt ruggedness	50	V/ns
	Diode Recovery dv/dt ruggedness ⁴⁾	15	
T_{STG}	Storage Temperature Range	-55 to 150	°C
T_J	Maximum Operating Junction Temperature	150	°C
T_L	Maximum Lead Temperature for Soldering, 1/8" from Case for 10 Seconds	260	°C

1) Limited by T_J max. Maximum duty cycle $D=0.75$.

2) Pulse width t_p limited by T_J , max.

3) $V_{DD}=50\text{V}$, $R_G=25\Omega$, Starting $T_J=25^\circ\text{C}$.

4) $V_{DClamp}=400\text{V}$; $V_{DS,peak} < V_{(BR)DSS}$; identical low side and high side switch with identical R_G .

Thermal Characteristics

Symbol	Parameter	Value	Unit
$R_{\theta JC}$	Thermal Resistance, Junction to Case, max $T_C = 25^\circ\text{C}$	4.9	°C/W
$R_{\theta JA}$	Thermal Resistance, Junction to Ambient, max $T_C = 25^\circ\text{C}$	49	

Electrical Characteristics ($T_J = 25^\circ\text{C}$ unless otherwise noted)

Symbol	Parameter	Test Conditions	Min	Typ	Max	Unit
--------	-----------	-----------------	-----	-----	-----	------

Off Characteristics

BV_{DSS}	Drain to Source Breakdown Voltage	$V_{GS} = 0\text{ V}, I_D = 250\mu\text{A}$	600	-	-	V
I_{DSS}	Zero Gate Voltage Drain Current	$V_{DS} = 600\text{ V}, V_{GS} = 0\text{ V}, T_J = 25^\circ\text{C}$	-	-	1	μA
		$V_{DS} = 600\text{ V}, V_{GS} = 0\text{ V}, T_J = 150^\circ\text{C}$	-	-	10	μA
I_{GSS}	Gate-Source Leakage Current	$V_{GS} = \pm 20\text{ V}, V_{DS} = 0\text{ V}$	-	-	± 100	nA

On Characteristics

$V_{GS(th)}$	Gate Threshold Voltage	$V_{GS} = V_{DS}, I_D = 250\mu\text{A}$	2	3	4	V
$R_{DS(on)}$	Static Drain to Source On Resistance	$V_{GS} = 10\text{ V}, I_D = 3.5\text{ A}, T_J = 25^\circ\text{C}$	-	500	600	mΩ

Dynamic Characteristics

C_{iss}	Input Capacitance	$V_{GS} = 0\text{V}, V_{DS} = 50\text{V}, f = 1\text{MHz}$	-	370	-	pF
C_{oss}	Output Capacitance		-	23	-	pF
C_{riss}	Reverse Transfer Capacitance		-	1.3	-	pF
$C_{o(er)}$	Energy Related Output Capacitance ¹⁾	$V_{DS} = 0\text{V to } 400\text{V}, V_{GS} = 0\text{V}$	-	16	-	pF
$C_{o(tr)}$	Time Related Output Capacitance ²⁾	$V_{DS} = 0\text{V to } 400\text{V}, V_{GS} = 0\text{V}$	-	87	-	pF
Q_g	Total Gate Charge	$V_{GS} = 0\text{-}10\text{V},$ $V_{DD} = 480\text{V}, I_D = 4\text{A}$	-	15	-	nC
Q_{gs}	Gate to Source Charge		-	2.4	-	nC
Q_{gd}	Gate to Drain "Miller" Charge		-	9	-	nC
$V_{plateau}$	Gate plateau voltage		-	6	-	V
R_G	Gate Resistance	$V_{GS} = 0\text{V}, f = 1\text{MHz}, \text{open drain}$	-	3.6	-	Ω

Switching Characteristics

$t_{d(on)}$	Turn-On Delay Time	$V_{GS} = 10\text{V}, V_{DD} = 400\text{V}, I_D = 4\text{A}$	-	18	-	ns
t_r	Turn-On Rise Time		-	12	-	ns
$t_{d(off)}$	Turn-Off Delay Time		-	50	-	ns
t_f	Turn-Off Fall Time		-	16	-	ns

Reverse Diode Characteristics

I_{SD}	Continuous Diode Forward Current	$T_C = 25^\circ\text{C}$	-	-	8	A
V_{SD}	Diode Forward Voltage	$V_{GS} = 0\text{V}, I_F = 4\text{A}, T_J = 25^\circ\text{C}$	-	0.86	-	V
t_{rr}	Reverse Recovery Time	$V_R = 400\text{V}, I_F = 4\text{A}$ $di_F/dt = 100\text{A}/\mu\text{s}$	-	200	-	ns
Q_{rr}	Reverse Recovery Charge		-	1.25	-	μC
I_{rm}	Reverse Recovery Current		-	14	-	A

1) $C_{o(er)}$ is a fixed capacitance that gives the same stored energy as C_{oss} while V_{DS} is rising from 0 to 400V.

2) $C_{o(tr)}$ is a fixed capacitance that gives the same charging time as C_{oss} while V_{DS} is rising from 0 to 400V.

Typical Performance Characteristics

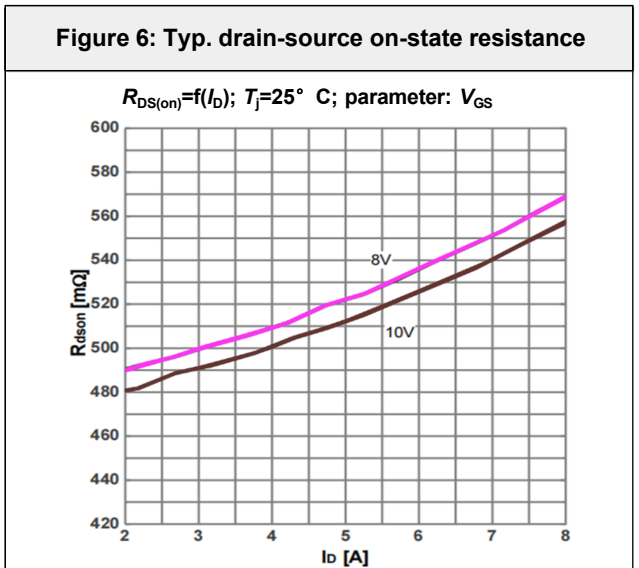
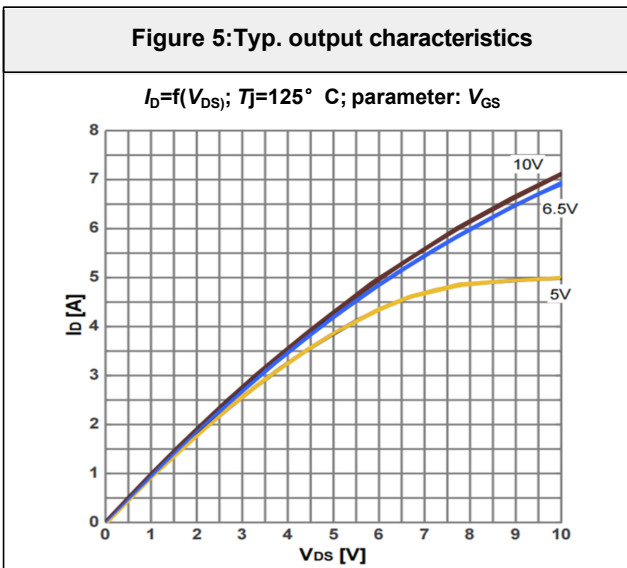
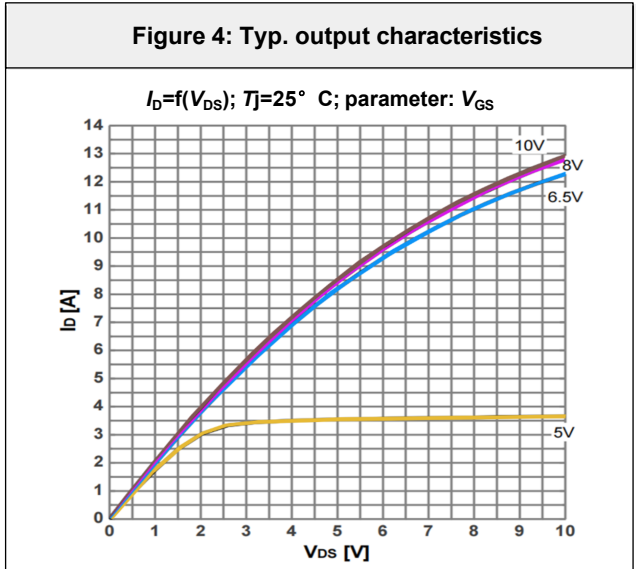
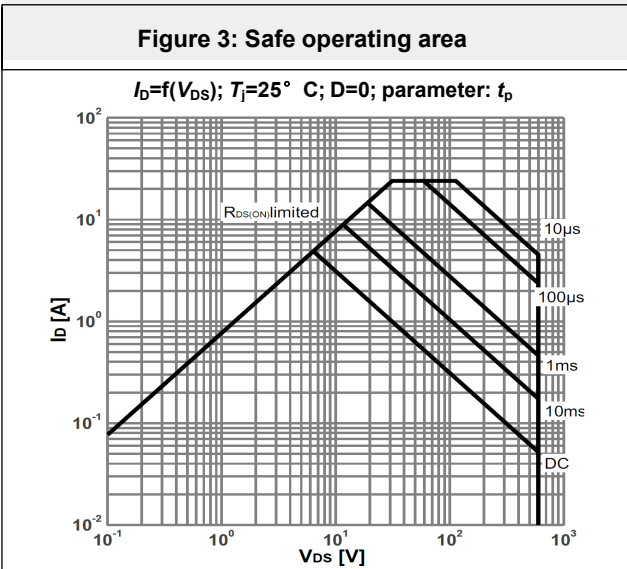
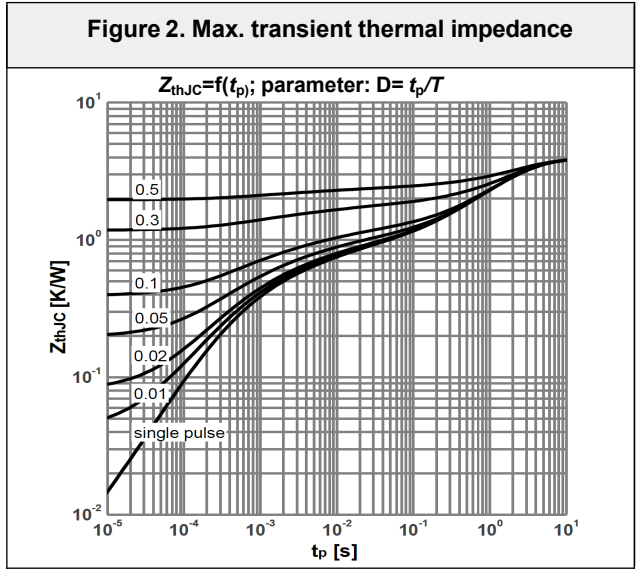
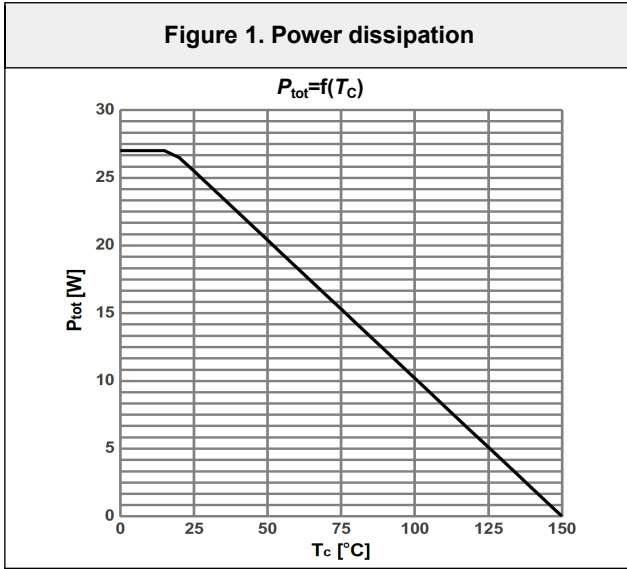

Typical Performance Characteristics

Figure 7: drain-source on-state resistance

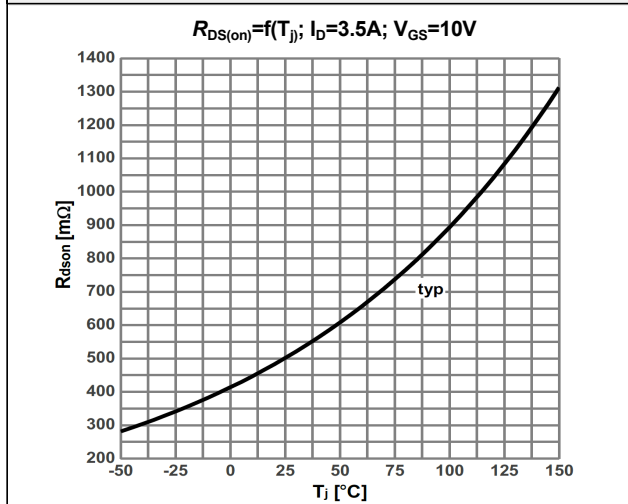

Figure 8: Typ. transfer characteristics

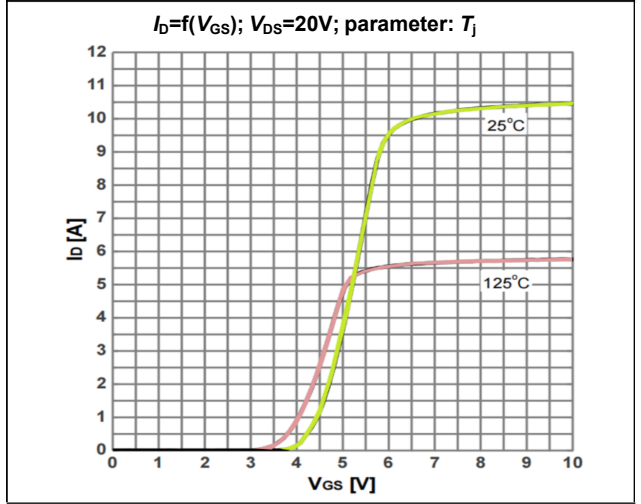

Figure 9:Typ. gate charge

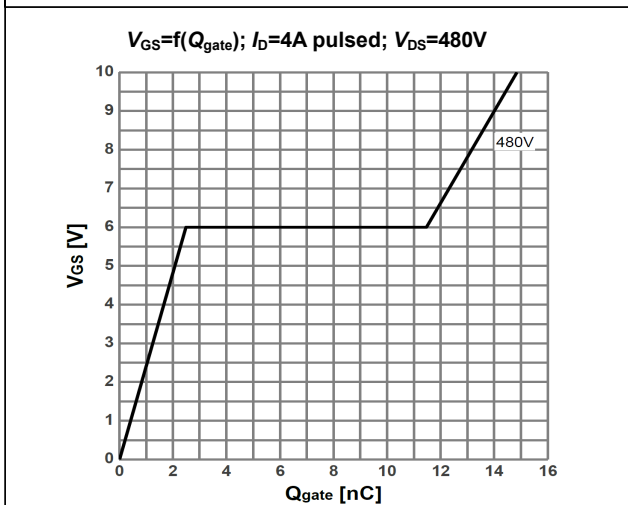

Figure 10:Forward characteristics of reverse diode

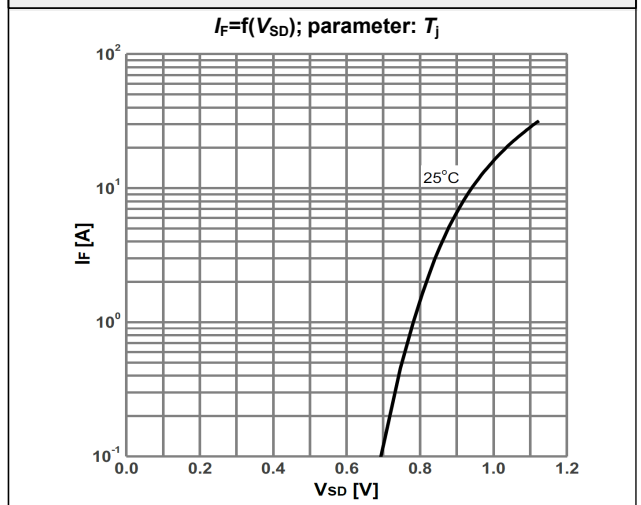

Figure 11:Drain-source breakdown voltage

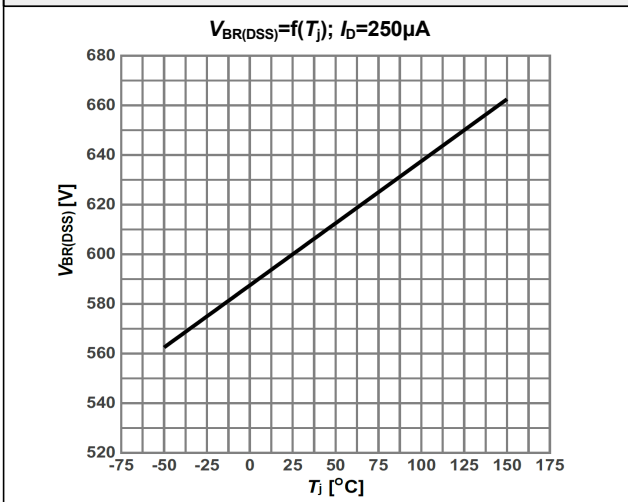
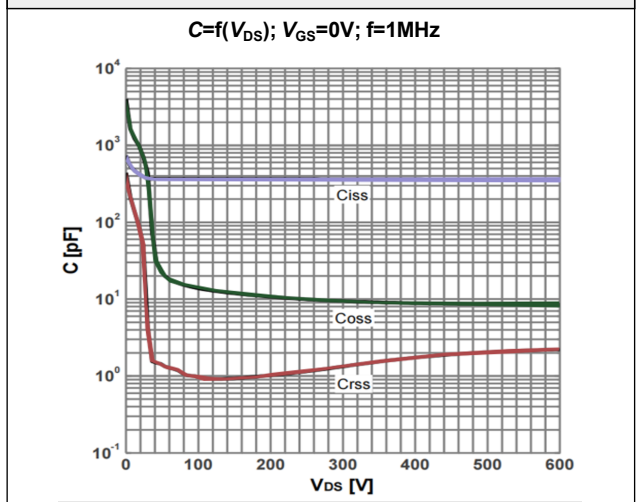
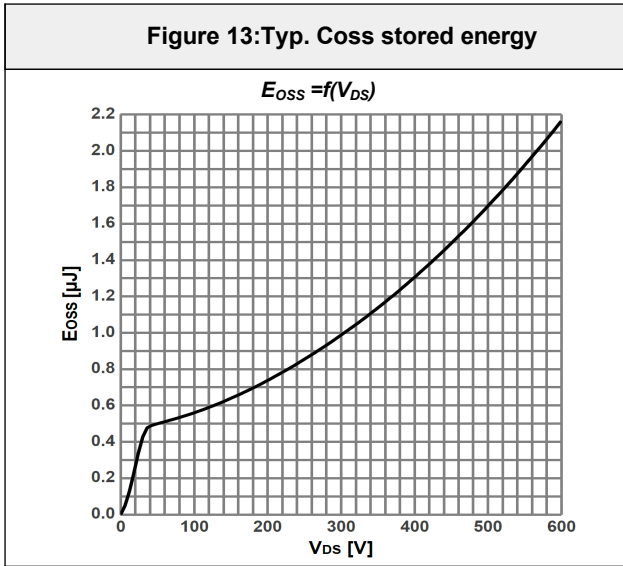

Figure 12:Typ. capacitances



Typical Performance Characteristics

Figure 13:Typ. Coss stored energy



Test Circuits

Figure 14: Diode Characteristics

Test circuit for diode characteristics and Diode recovery waveform

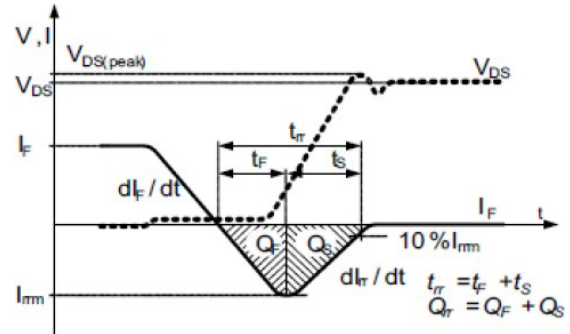
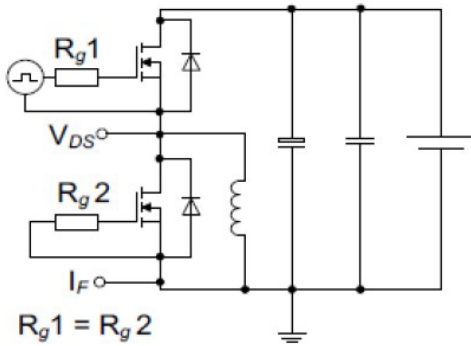

Figure 15: Switching Times

Switching times test circuit for inductive load and Switching times waveform

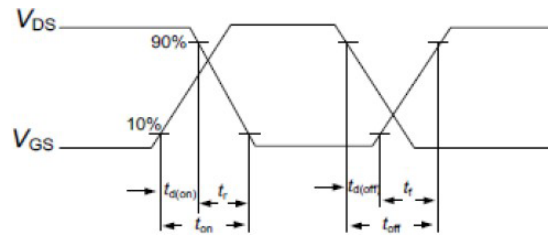
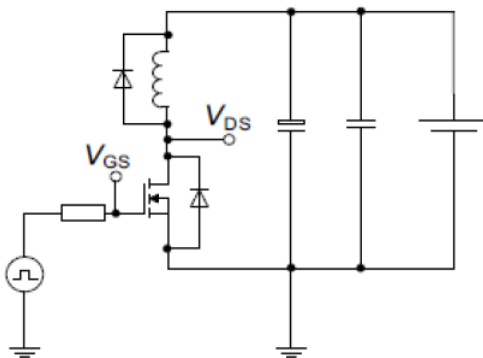
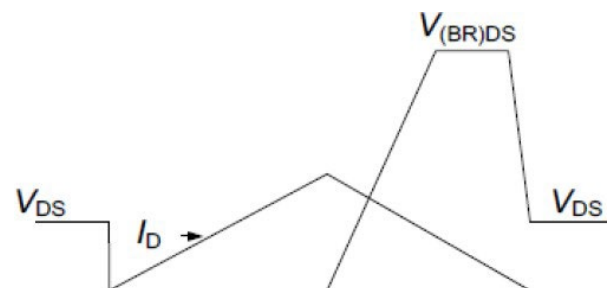
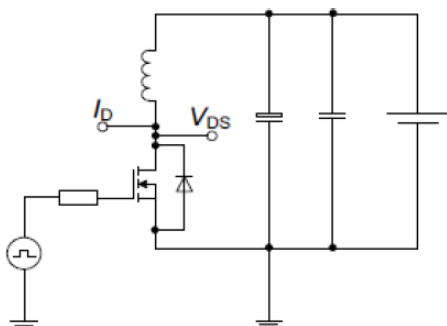

Figure 16: Unclamped Inductive Load

Unclamped inductive load test circuit and Unclamped inductive waveform



Package Outlines

TO-220F

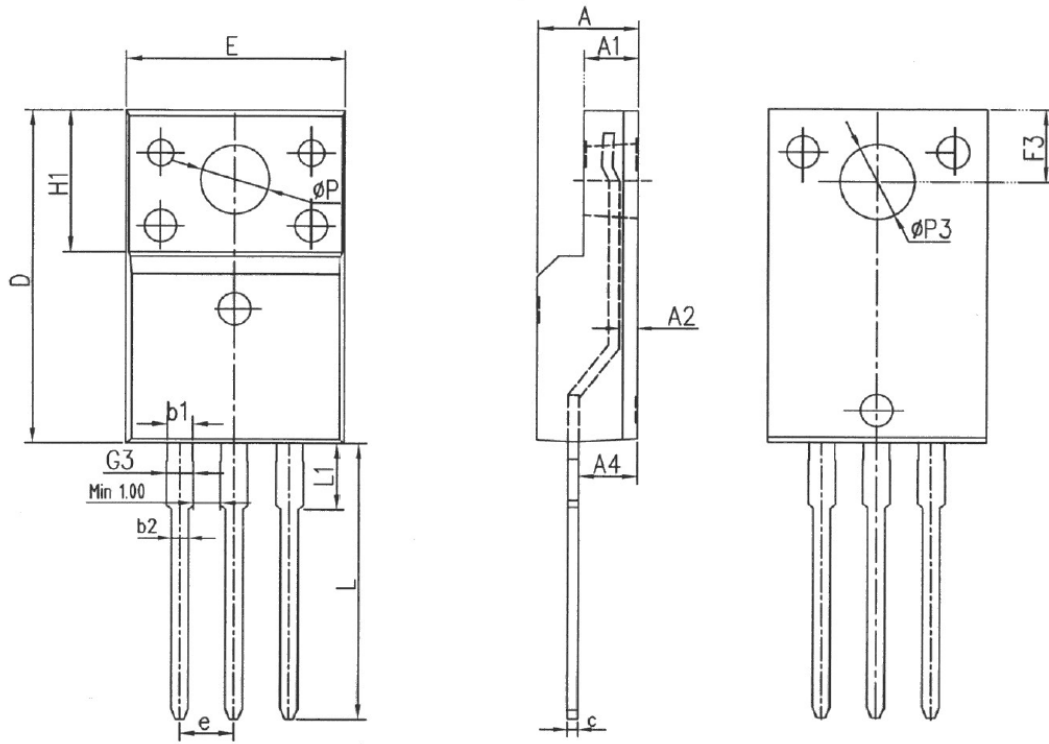

SYMBOL	MM		
	MIN	NOM	MAX
E	10.00	10.20	10.40
A	4.50	4.70	4.90
A1	2.34	2.54	2.74
A2	0.65	0.85	1.30
A4	2.55	2.75	2.95
c	0.40	0.50	0.65
D	15.57	15.87	16.17
H1	6.70REF		
e	2.54BSC		
ΦP	3.183REF		
L	12.68	12.98	13.28
L1	3.25	3.45	3.65
ΦP3	3.45REF		
F3	3.10	3.30	3.50
G3	1.10	1.30	1.50
b1	1.05	1.20	1.35
b2	0.70	0.80	0.92

* Dimensions in millimeters

Package Marking and Ordering Information

Part Number	Top Marking	Package	Packing Method	Quantity
BMF60N600C1	BMF60N600C1	TO220F	Tube	50 units

Disclaimer

Bestirpower reserve the right to make changes, corrections, enhancements, modifications, and improvements to Bestirpower products and/or to this document at any time without notice.

The information given in this document shall in no event be regarded as a guarantee of conditions or characteristics. Bestirpower does not assume any liability for infringement of patents, copyrights, or other intellectual property rights of third parties by or arising from the use of Products or technical information described in this document.

This document is the property of Bestirpower Co., LTD., and not allowed to copy or transformed to other format if not under the authority approval.

© 2024 bestirpower – All rights reserved