

BMT65N100UC1

Super Junction Power MOSFET

650 V, 35 A, 100 mΩ



Description

BMT65N100UC1 is power MOSFET using bestirpower's advanced super junction technology that can realize very low on resistance and gate charge. It will provide much high efficiency by using optimized charge coupling technology. These user friendly devices give an advantage of Low EMI to designers as well as low switching loss.

Applications

- AC/DC power supply.
- PC power.
- Telecom/Sever.
- Solar invertor.

Features

$BV_{DSS} @ T_{J,max}$	I_D	$R_{DS(on),max}$	$Q_{g,typ}$
700 V	35 A	100 mΩ	66 nC

- Ultra-fast body diode.
- Extremely low losses due to very low FOM $R_{dson} * Q_g$ and E_{oss} .
- Very high commutation ruggedness.

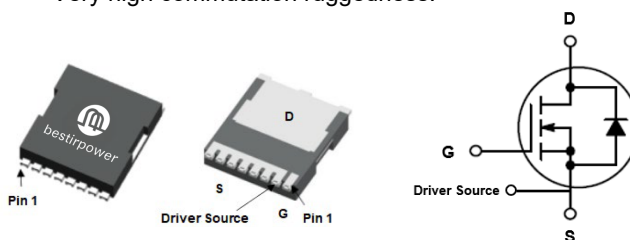

Absolute Maximum Ratings ($T_J = 25^\circ\text{C}$ unless otherwise noted)

Symbol	Parameter	Value max	Unit
V_{DSS}	Drain to Source Voltage(1)	650	V
V_{GSS}	Gate to Source Voltage	± 30	V
I_D	Drain Current(2)	$V_{GS} = 10 \text{ V}, (T_C = 25^\circ\text{C})$	35
		$V_{GS} = 10 \text{ V}, (T_C = 100^\circ\text{C})$	22
I_{DM}	Drain Current	Pulsed	105
E_{AS}	Single Pulsed Avalanche Energy(3)	750	mJ
dv/dt	MOSFET dv/dt ruggedness	50	V/ns
	Peak Diode Recovery dv/dt	50	
P_D	Power Dissipation	($T_C = 25^\circ\text{C}$)	278
T_J, T_{STG}	Operating and Storage Temperature Range	-55 to 150	$^\circ\text{C}$
I_S	Continuous diode forward current	35	A
$I_{S \text{ Pulse}}$	Diode pulse current(2)	105	A

1) Limited by T_J max. Maximum duty cycle $D=0.75$.

2) Pulse width t_p limited by T_J,max .

3) $V_{DD}=50\text{V}$, $R_G=25\Omega$, Starting $T_J=25^\circ\text{C}$.

4) $V_{DClink}=400\text{V}$; $V_{DS,peak} < V(BR)_{DSS}$; identical low side and high side switch with identical R_G .

Thermal Characteristics

Symbol	Parameter	Value	Unit
$R_{\theta C}$	Thermal Resistance, Junction to Case, Max.	0.45	$^\circ\text{C/W}$
$R_{\theta A}$	Thermal Resistance, Junction to Ambient, Max.	62	
T_{sold}	Soldering temperature, wavesoldering only allowed at leads	260	$^\circ\text{C}$

Electrical Characteristics (T_J = 25°C unless otherwise noted)

Symbol	Parameter	Test Conditions	Min	Typ	Max	Unit
Off Characteristics						
BV _{DSS}	Drain to Source Breakdown Voltage	V _{GS} = 0 V, I _D = 1 mA	650	-	-	V
I _{DSS}	Zero Gate Voltage Drain Current	V _{DS} = 650 V, V _{GS} = 0 V	-	-	10	μA
I _{GSS}	Gate-Source Leakage Current	V _{GS} = ± 30V, V _{DS} = 0 V	-	-	±100	nA

On Characteristics

V _{GS(th)}	Gate Threshold Voltage	V _{GS} = V _{DS} , I _D = 250 μA	3.0	4.0	5.0	V
R _{DS(on)}	Static Drain to Source On Resistance	V _{GS} = 10 V, I _D = 18A T _J = 25°C	-	82	100	mΩ

Dynamic Characteristics

C _{iss}	Input Capacitance	V _{GS} = 0V, V _{DS} = 50V, f = 250KHz	-	2990	-	pF
C _{oss}	Output Capacitance		-	141	-	pF
C _{rss}	Reverse transfer capacitance		-	5.8	-	pF
C _{o(tr)}	Time Related Output Capacitance ²⁾	V _{DS} = 0 to 400 V, V _{GS} = 0 V	-	452	-	pF
C _{o(er)}	Energy Related Output Capacitance ¹⁾		-	88	-	pF
Q _{g(tot)}	Total Gate Charge at 10 V	V _{DD} = 400 V, I _D = 18A, V _{GS} = 0 to 10 V	-	66	-	nC
Q _{gs}	Gate to Source Charge		-	20	-	nC
Q _{gd}	Gate to Drain "Miller" Charge		-	25	-	nC
V _{plateau}	Gate plateau voltage		-	6.1	-	V
R _G	Gate Resistance	f = 1 MHz open drain	-	2.7	-	Ω
t _{d(on)}	Turn-On Delay Time	V _{DD} = 400 V, I _D = 18A, V _{GS} = 10 V,	-	21	-	ns
t _r	Turn-On Rise Time		-	19	-	ns
t _{d(off)}	Turn-Off Delay Time		-	76	-	ns
t _f	Turn-Off Fall Time		-	8	-	ns

Source-Drain Diode Characteristics

V _{SD}	Diode Forward Voltage	V _{GS} = 0 V, I _F = 18A T _J = 25°C	-	0.88	-	V
t _{rr}	Reverse Recovery Time	V _R = 400 V, I _F = 18 A, di _F /dt = 100 A/μs	-	140	-	ns
Q _{rr}	Reverse Recovery Charge		-	1.15	-	μC
I _{rm}	Peak reverse recovery current		-	15	-	A

1) C_{o(er)} is a fixed capacitance that gives the same stored energy as C_{oss} while V_{DS} is rising from 0 to 400V.

2) C_{o(tr)} is a fixed capacitance that gives the same charging time as C_{oss} while V_{DS} is rising from 0 to 400V.

Typical Performance Characteristics

Figure 1. Power dissipation

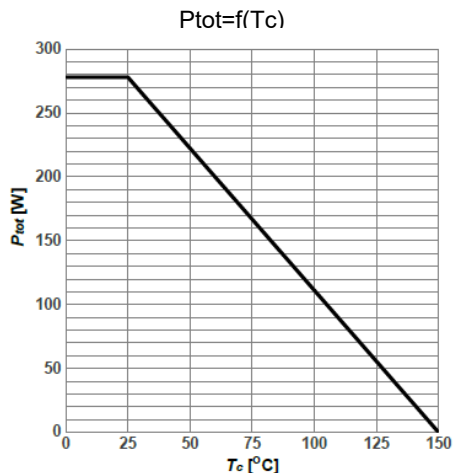

Figure 2: Max. transient thermal impedance

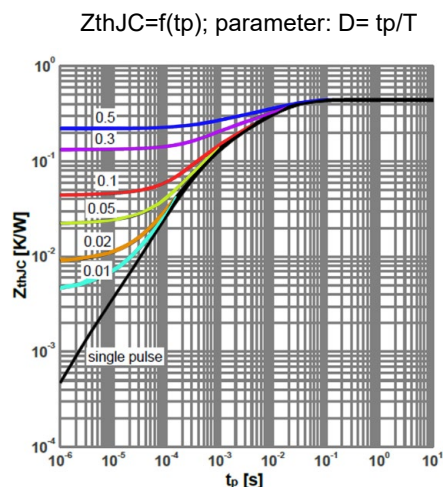

Figure 3: Safe operating area

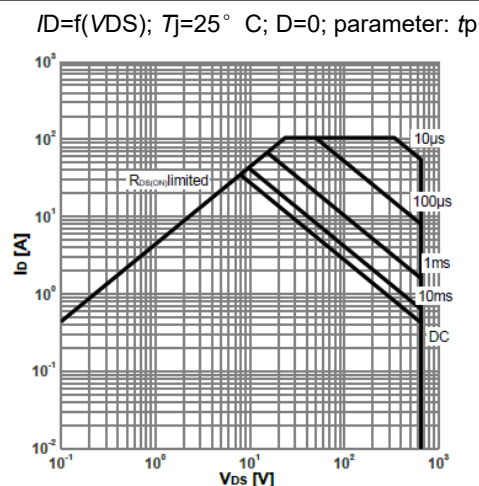

Figure 4: Typ. output characteristics

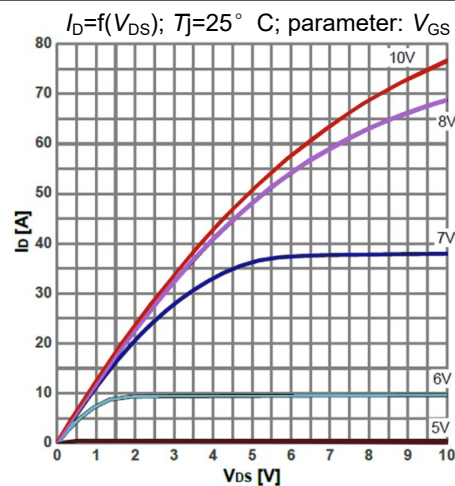

Figure 5: Typ. output characteristics

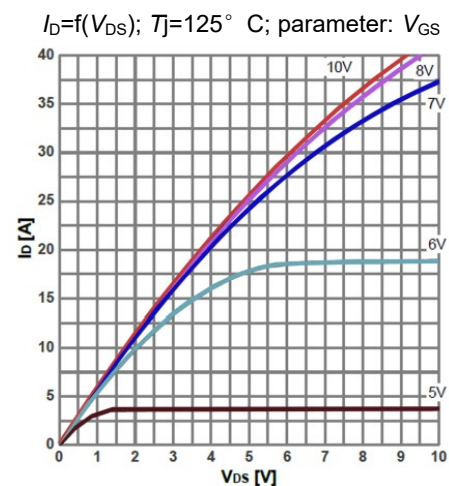
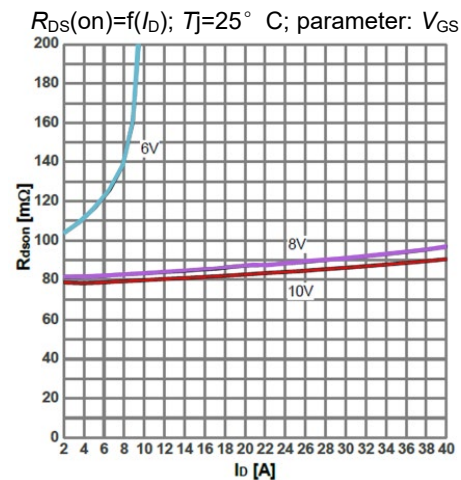

Figure 6: Typ. drain-source on-state resistance



Typical Performance Characteristics

Figure 7: Drain-source on-state resistance

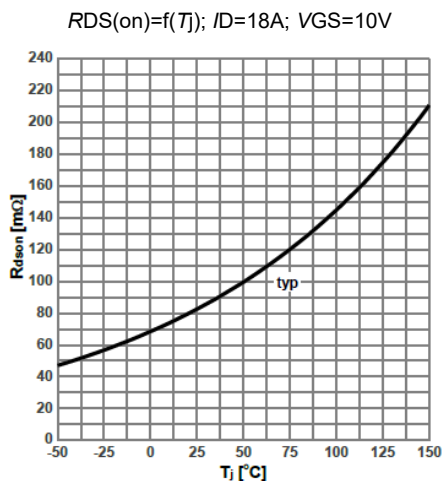

Figure 8: Typ. transfer characteristics

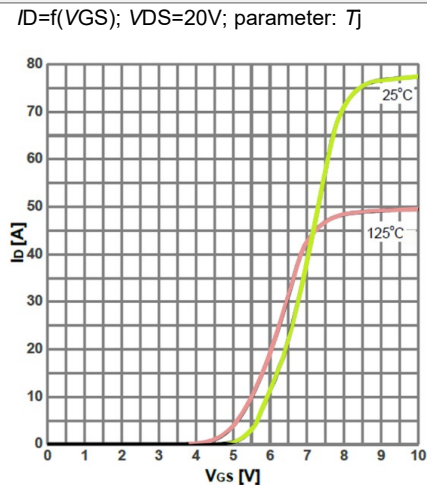

Figure 9: Typ. gate charge

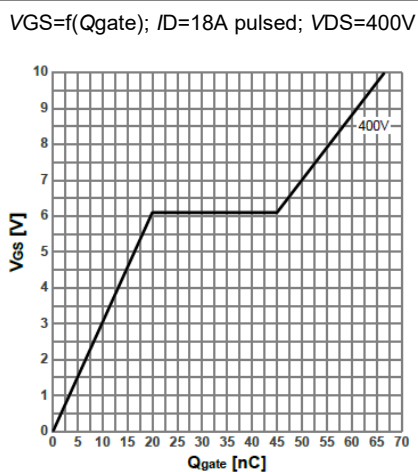

Figure 10: Forward characteristics of reverse diode

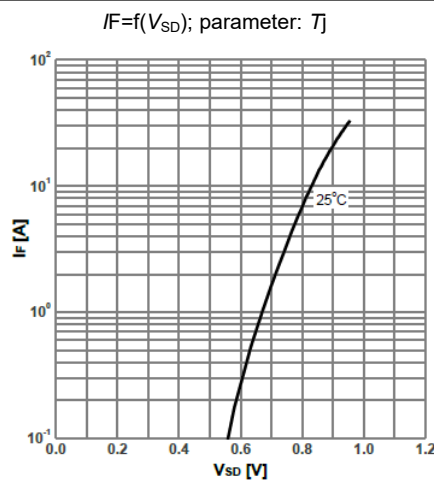

Figure 11: Drain-source breakdown voltage

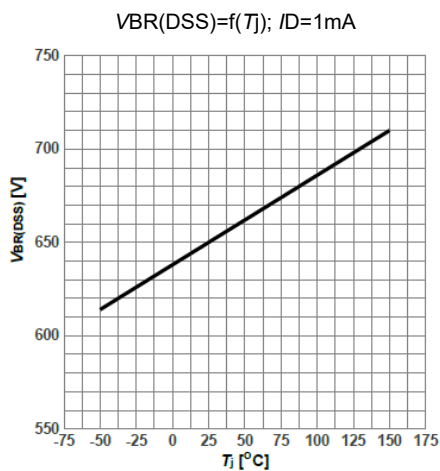
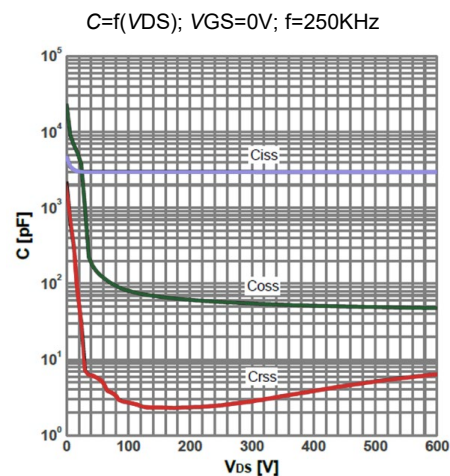

Figure 12: Typ. capacitances



Typical Performance Characteristics

Figure 13: Typ. Coss stored energy

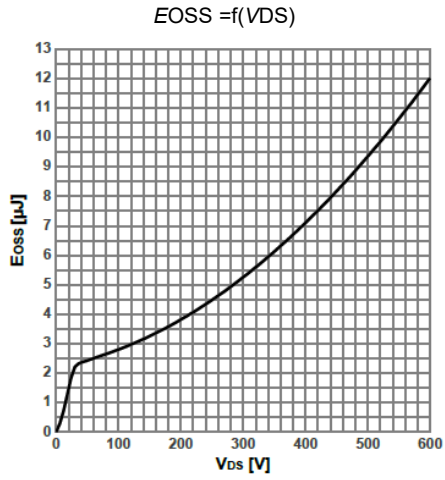
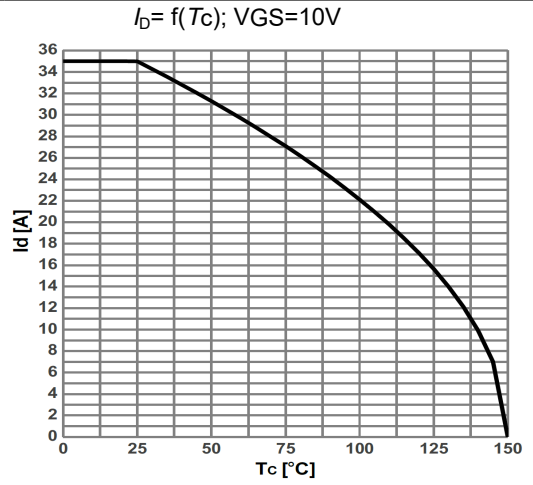

Figure 14: Max. Drain Current



Test Circuits

Figure 15. Diode Characteristics

Test circuit for diode characteristics and Diode recovery waveform

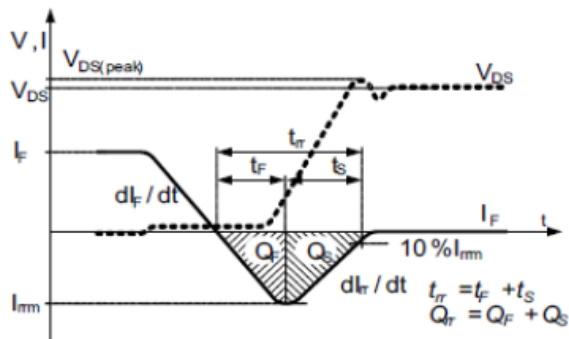
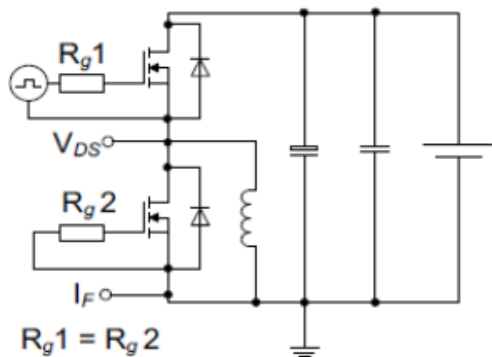

Figure 16. Switching Times

Switching times test circuit for inductive load and Switching times waveform

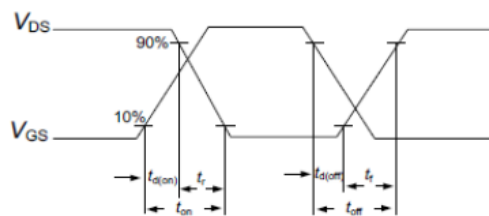
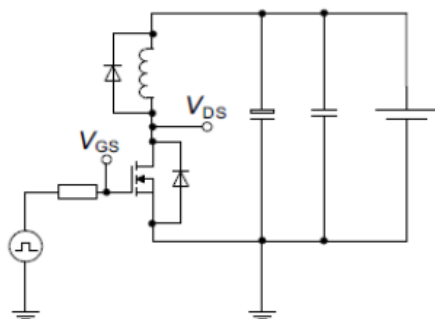
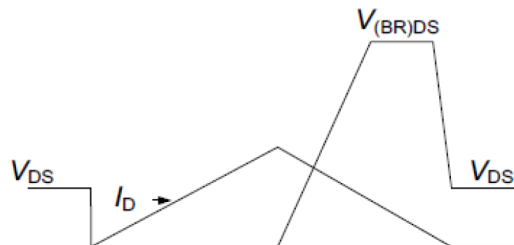
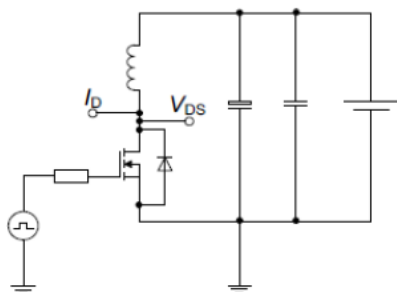

Figure 17 Unclamped Inductive Load

Unclamped inductive load test circuit and Unclamped inductive waveform



Package Outlines

TOLL

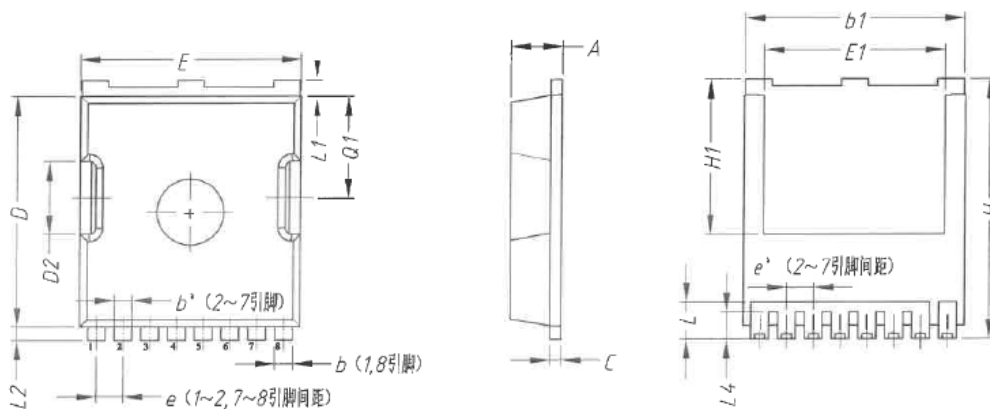

SYMBOL	MM		
	MIN	NOM	MAX
A	2.15	2.30	2.45
b	0.75	0.75	0.85
b'	0.70	0.70	0.80
b1	9.65	9.80	9.95
C	0.45	0.50	0.60
D	10.18	10.38	10.58
D2	3.15	3.30	3.45
E	9.70	9.90	10.10
E1	7.95	8.10	8.25
e	BSC 1.225		
e'	BSC 1.20		
Q1	4.40	4.55	4.70
H	11.48	11.68	11.88
H1	6.80	6.95	7.10
L	1.60	1.80	2.00
L1	0.50	0.70	0.90
L2	0.48	0.60	0.72
L4	1.00	1.15	1.30

* Dimensions in millimeters

BMT65N100UC1

650 V 100 mΩ Power MOSFET



Package Marking and Ordering Information

Part Number	Top Marking	Package	Packing Method	Quantity
BMT65N100UC1	BMT65N100UC1	TOLL	Tape and Reel	1200 Units

Disclaimer

Bestirpower reserve the right to make changes, corrections, enhancements, modifications, and improvements to Bestirpower products and/or to this document at any time without notice.

The information given in this document shall in no event be regarded as a guarantee of conditions or characteristics. Bestirpower does not assume any liability for infringement of patents, copyrights, or other intellectual property rights of third parties by or arising from the use of Products or technical information described in this document.

This document is the property of Bestirpower Co., LTD., and not allowed to copy or transformed to other format if not under the authority approval.

© 2024 bestirpower – All rights Reserved