



General Description

LD1117SxxCTR is a series of low dropout three-terminal regulators with a dropout of 1.3V at 800mA load current. LD1117SxxCTR features a very low standby current 2mA compared to 5mA of competitor.

Other than a fixed version, $V_{out} = 1.2V, 1.8V, 2.5V, 2.85V, 3.3V,$ and $5V$, LD1117SxxCTR has an adjustable version, which can provide an output voltage from 1.25 to 12V with only two external resistors.

LD1117SxxCTR offers thermal shut down function, to assure the stability of chip and power system. And it uses trimming technique to guarantee output voltage accuracy within 2%. Other output voltage accuracy can be customized on demand, such as 1%.

LD1117SxxCTR is available in SOT-223 power package.

Features

- Maximum output current is 0.8A
- Range of operation input voltage: Max 15V
- Line regulation: 0.03%/V (typ.)
- Standby current: 2mA (typ.)
- Load regulation: 0.2%/A (typ.)
- Environment Temperature: $-20^{\circ}C \sim 85^{\circ}C$

Application

- Power Management for Computer Mother Board, Graphic Card
- LCD Monitor and LCD TV
- DVD Decode Board
- ADSL Modem
- Post Regulators For Switching Supplies

Pin Configuration And Descriptions

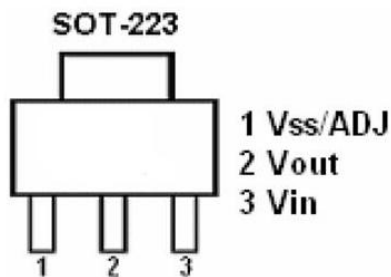

Order Information

Orderable Device	Package	Output Voltage	Packing Option
LD1117SxxCTR	SOT-223	1.2V, 1.8V, 2.5V, 2.85V, 3.3V, 5.0V, adj	2500/Reel

xx: From 12-50, ADJ



Absolute Maximum Ratings

Description	Symbol	Value Range	Unit
MAX Input Voltage	V_{IN}	18	V
Max Operating Junction Temperature	T_j	150	°C
Storage Temperature	T_s	-55~+150	°C
Recommended operating junction temperature	T_j	-20~125	°C

Note: Stresses greater than those listed under “Absolute Maximum Ratings” may cause permanent damage to the device. These are stress ratings only, and functional operation of the device at these or any other conditions beyond those indicated under “Recommended Operating Conditions” is not implied. Exposure to “Absolute Maximum Ratings” for extended periods may affect device reliability.

Heat Dissipation

Description	Symbol	Package	Value Range	Unit
Thermal resistance	J_A	SOT-223	20	°C/W

Block Diagram

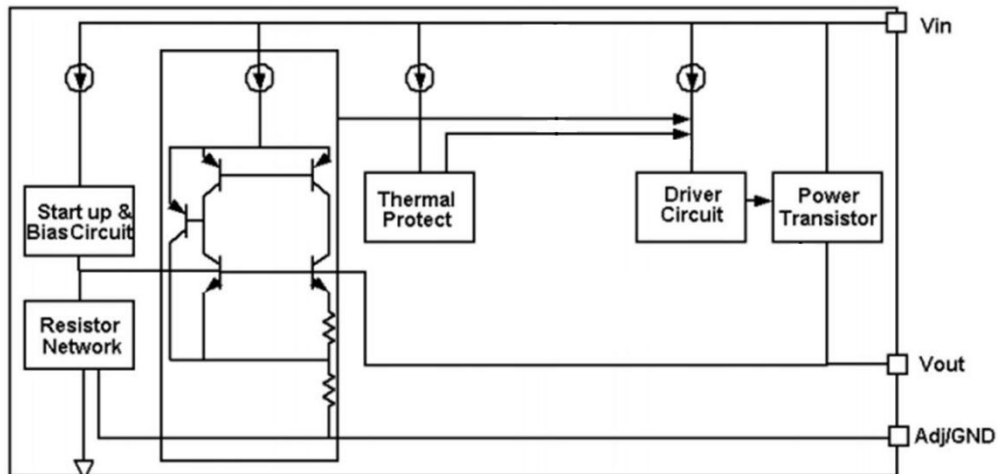



DC Characteristics (unless otherwise noted $T_A = 25^\circ\text{C}$)

Symbol	Parameter	Conditions	Min	Typ	Max	Unit
Vref	Reference voltage	LD1117SADJCTR $10\text{mA} \leq I_{\text{out}} \leq 800\text{mA}$, $V_{\text{in}} = 3.25\text{V}$	1.225	1.25	1.275	V
Vout	Output voltage	LD1117S12CTR $0 \leq I_{\text{out}} \leq 800\text{mA}$, $V_{\text{in}} = 3.2\text{V}$	1.176	1.2	1.224	V
		LD1117S18CTR $0 \leq I_{\text{out}} \leq 800\text{mA}$, $V_{\text{in}} = 3.8\text{V}$	1.764	1.8	1.836	V
		LD1117S25CTR $0 \leq I_{\text{out}} \leq 800\text{mA}$, $V_{\text{in}} = 4.5\text{V}$	2.45	2.5	2.55	V
		LD1117S285CTR $0 \leq I_{\text{out}} \leq 800\text{mA}$, $V_{\text{in}} = 4.85\text{V}$	2.793	2.85	2.907	V
		LD1117S33CTR $0 \leq I_{\text{out}} \leq 800\text{mA}$, $V_{\text{in}} = 5.3\text{V}$	3.234	3.3	3.366	V
		LD1117S50CTR $0 \leq I_{\text{out}} \leq 800\text{mA}$, $V_{\text{in}} = 7.0\text{V}$	4.9	5	5.1	V
ΔV_{out}	Line regulation	LD1117S12CTR $I_{\text{out}} = 10\text{mA}$, $2.7\text{V} \leq V_{\text{in}} \leq 10\text{V}$		0.03	0.2	%/V
		LD1117SADJCTR $I_{\text{out}} = 10\text{mA}$, $2.75\text{V} \leq V_{\text{in}} \leq 12\text{V}$		0.03	0.2	%/V
		LD1117S18CTR $I_{\text{out}} = 10\text{mA}$, $3.3\text{V} \leq V_{\text{in}} \leq 12\text{V}$		0.03	0.2	%/V
		LD1117S25CTR $I_{\text{out}} = 10\text{mA}$, $4.0\text{V} \leq V_{\text{in}} \leq 12\text{V}$		0.03	0.2	%/V
		LD1117S285CTR $I_{\text{out}} = 10\text{mA}$, $4.35\text{V} \leq V_{\text{in}} \leq 12\text{V}$		0.03	0.2	%/V
		LD1117S33CTR $I_{\text{out}} = 10\text{mA}$, $4.8\text{V} \leq V_{\text{in}} \leq 12\text{V}$		0.03	0.2	%/V
		LD1117S50CTR $I_{\text{out}} = 10\text{mA}$, $6.5\text{V} \leq V_{\text{in}} \leq 12\text{V}$		0.03	0.2	%/V
ΔV_{out}	Load regulation	LD1117S12CTR $V_{\text{in}} = 2.7\text{V}$, $10\text{mA} \leq I_{\text{out}} \leq 800\text{mA}$		2	8	mV
		LD1117SADJCTR $V_{\text{in}} = 2.75\text{V}$, $10\text{mA} \leq I_{\text{out}} \leq 800\text{mA}$		2	8	mV
		LD1117S18CTR $V_{\text{in}} = 3.3\text{V}$, $10\text{mA} \leq I_{\text{out}} \leq 800\text{mA}$		3	12	mV
		LD1117S25CTR $V_{\text{in}} = 4.0\text{V}$, $10\text{mA} \leq I_{\text{out}} \leq 800\text{mA}$		4	16	mV
		LD1117S285CTR $V_{\text{in}} = 4.35\text{V}$, $10\text{mA} \leq I_{\text{out}} \leq 800\text{mA}$		5	20	mV
		LD1117S33CTR $V_{\text{in}} = 4.8\text{V}$, $10\text{mA} \leq I_{\text{out}} \leq 800\text{mA}$		6	24	mV
		LD1117S50CTR $V_{\text{in}} = 6.5$, $10\text{mA} \leq I_{\text{out}} \leq 800\text{mA}$		9	36	mV



Vdrop	Dropout voltage	lout =100mA		1.2	1.3	V
		lout=800mA		1.3	1.5	V
Imin	Minimum load current	LD1117SADJCTR		2	10	mA
Iq	Quiescent Current	LD1117S12CTR, Vin=10V		2	5	mA
		LD1117S18CTR, Vin=12V		2	5	mA
		LD1117S25CTR, Vin=12V		2	5	mA
		LD1117S285CTR, Vin=12V		2	5	mA
		LD1117S33CTR, Vin=12V		2	5	mA
		LD1117S50CTR, Vin=12V		2	5	mA
IAdj	Adjust pin current	LD1117SADJCTR Vin=5V, 10mA ≤ Iout ≤ 800mA		55	120	uA
Ichange	Iadj change	LD1117SADJCTR Vin=5V, 10mA ≤ Iout ≤ 800mA		0.2	10	uA
OTP	Thermal Shutdown	Junction Temperature		+200		°C
	Thermal Shutdown Hysteresis	Junction Temperature		+30		°C
ΔV/ΔT	Temperature coefficient			± 100		ppm
θ _{JC}	Thermal resistance	SOT-223		20		°C/W

Note1: All test are conducted under ambient temperature 25°C and within a short period of time 20ms

Note2: Load current smaller than minimum load current of LD1117SADJCTR will lead to unstable or oscillation output.

Application Circuit

Basic Circuits

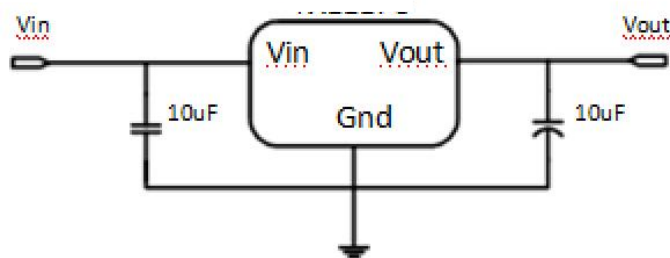

Application circuit of LD1117SxxCTR fixed version



Function Description

LD1117SxxCTR is a series of low dropout voltage, three terminal regulators. Its application circuit is very simple: the fixed version only needs two capacitors and the adjustable version only needs two resistors and two capacitors to work. It is composed of some modules including start-up circuit, bias circuit, bandgap, thermal shutdown, power transistors and its drive circuit and so on.

The thermal shut down modules can assure chip and its application system working safety when the junction temperature is larger than 140°C.

The bandgap module provides stable reference voltage, whose temperature coefficient is compensated by careful design considerations. The temperature coefficient is under 100 ppm/°C. And the accuracy of output voltage is guaranteed by trimming technique.

Typical Application

LD1117SxxCTR has an adjustable version and six fixed versions (1.2V, 1.8V, 2.5V, 2.85V, 3.3V and 5V)

Fixed Output Voltage Version

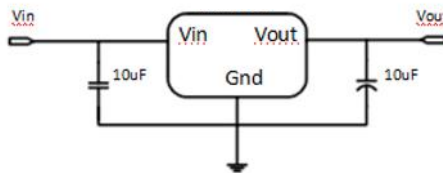

Application circuit of LD1117SxxCTR fixed version

- 1) Recommend using 10uF tan capacitor as bypass capacitor (C1) for all application circuit.
- 2) Recommend using 10uF tan capacitor to assure circuit stability.

Adjustable Output Voltage Version

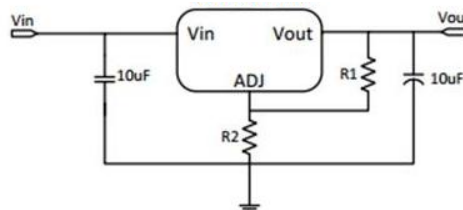

Application Circuit of LD1117SADJCTR

The output voltage of adjustable version follows the equation: $V_{out} = 1.25 \times (1 + R_2/R_1) + I_{Adj} \times R_2$. We can ignore I_{Adj} because I_{Adj} (about 50uA) is much less than the current of R_1 (about 2~10mA).

1) To meet the minimum load current (>10mA) requirement, R_1 is recommended to be 125ohm or lower. As LD1117SADJCTR can keep itself stable at load current about 2mA, R_1 is not allowed to be higher than 625ohm.

2) Using a bypass capacitor (C_{ADJ}) between the ADJ pin and ground can improve ripple rejection. This bypass capacitor prevents ripple from being amplified as the output voltage is increased. The impedance of C_{ADJ} should be less than R_1 to prevent ripple from being amplified. As R_1 is normally in the range of 100Ω~500Ω, the value of C_{ADJ} should satisfy this equation: $1/(2\pi \times f_{ripple} \times C_{ADJ}) < R_1$.



Thermal Considerations

We have to take heat dissipation into great consideration when output current or differential voltage of input and output voltage is large. Because in such cases, the power dissipation consumed by LD1117xxCTR is very large. LD1117SxxCTR series uses SOT-223 package type and its thermal resistance is about 20°C/W. And the copper area of application board can affect the total thermal resistance. If copper area is 5cm*5cm (two sides), the resistance is about 30°C/W. So the total thermal resistance is about 20°C/W+30°C/W. We can decrease total thermal resistance by increasing copper area in application board. When there is no good heat dissipation copper area in PCB, the total thermal resistance will be as high as 120°C/W, then the power dissipation of LD1117SxxCTR could allow on itself is less than 1W. And furthermore, LD1117SxxCTR will work at junction temperature higher than 125°C under such condition and no lifetime is guaranteed.

Typical Characteristics

Line regulation

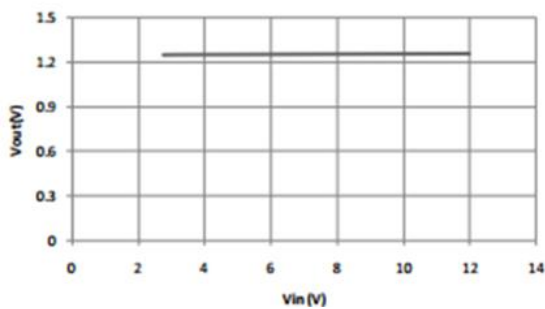

Load regulation

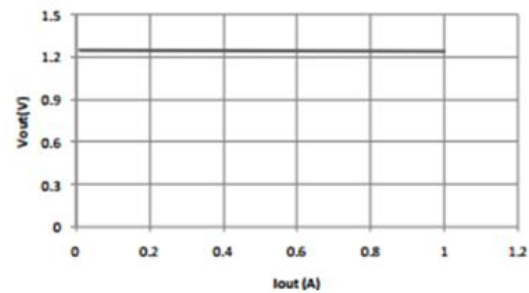

Dropout voltage

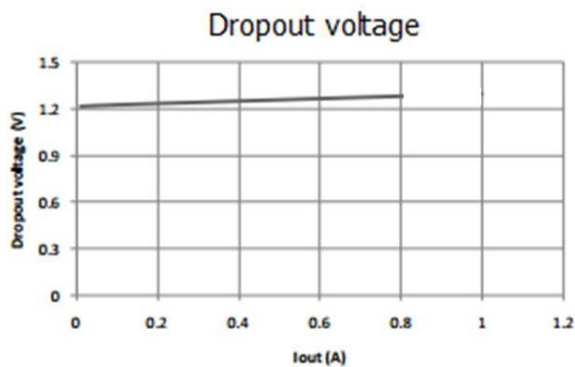

Thermal performance with OTP

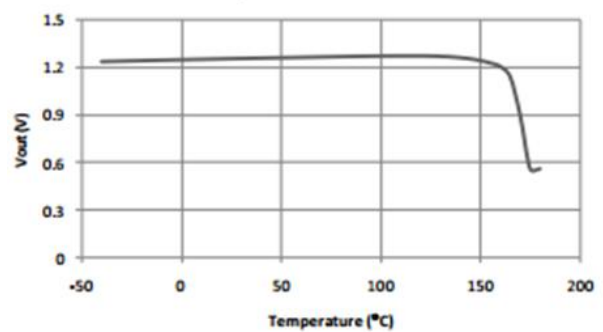



Package Outline Dimensions
SOT-223

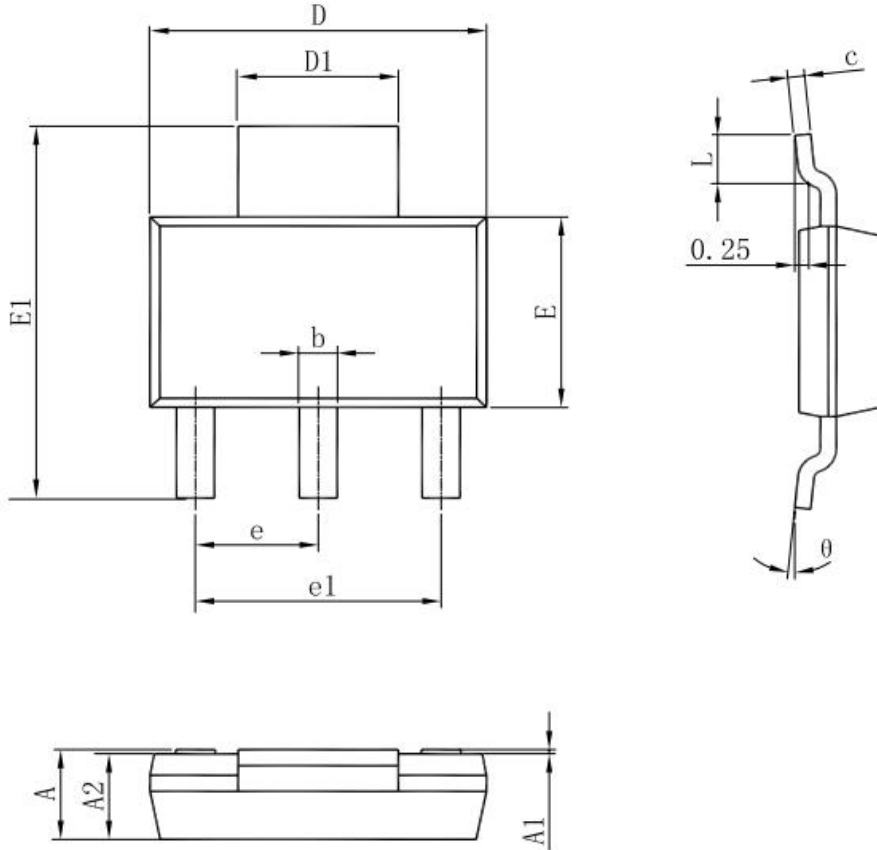

Symbol	Dimensions In Millimeters		Dimensions In Inches	
	Min	Max	Min	Max
A	1.520	1.800	0.060	0.071
A1	0.000	0.100	0.000	0.004
A2	1.500	1.700	0.059	0.067
b	0.660	0.820	0.026	0.032
c	0.250	0.350	0.010	0.014
D	6.200	6.400	0.244	0.252
D1	2.900	3.100	0.114	0.122
E	3.300	3.700	0.130	0.146
E1	6.830	7.070	0.269	0.278
e	2.300(BSC)		0.091(BSC)	
e1	4.500	4.700	0.177	0.185
L	0.900	1.150	0.035	0.045
θ	0°	10°	0°	10°



Attention

- Any and all HUA XUAN YANG ELECTRONICS products described or contained herein do not have specifications that can handle applications that require extremely high levels of reliability, such as life-support systems, aircraft's control systems, or other applications whose failure can be reasonably expected to result in serious physical and/or material damage. Consult with your HUA XUAN YANG ELECTRONICS representative nearest you before using any HUA XUAN YANG ELECTRONICS products described or contained herein in such applications.
- HUA XUAN YANG ELECTRONICS assumes no responsibility for equipment failures that result from using products at values that exceed, even momentarily, rated values (such as maximum ratings, operating condition ranges, or other parameters) listed in products specifications of any and all HUA XUAN YANG ELECTRONICS products described or contained herein.
- Specifications of any and all HUA XUAN YANG ELECTRONICS products described or contained herein stipulate the performance, characteristics, and functions of the described products in the independent state, and are not guarantees of the performance, characteristics, and functions of the described products as mounted in the customer's products or equipment. To verify symptoms and states that cannot be evaluated in an independent device, the customer should always evaluate and test devices mounted in the customer's products or equipment.
- HUA XUAN YANG ELECTRONICS CO.,LTD. strives to supply high-quality high-reliability products. However, any and all semiconductor products fail with some probability. It is possible that these probabilistic failures could give rise to accidents or events that could endanger human lives, that could give rise to smoke or fire, or that could cause damage to other property. When designing equipment, adopt safety measures so that these kinds of accidents or events cannot occur. Such measures include but are not limited to protective circuits and error prevention circuits for safe design, redundant design, and structural design.
- In the event that any or all HUA XUAN YANG ELECTRONICS products(including technical data, services) described or contained herein are controlled under any of applicable local export control laws and regulations, such products must not be exported without obtaining the export license from the authorities concerned in accordance with the above law.
- No part of this publication may be reproduced or transmitted in any form or by any means, electronic or mechanical, including photocopying and recording, or any information storage or retrieval system, or otherwise, without the prior written permission of HUA XUAN YANG ELECTRONICS CO.,LTD.
- Information (including circuit diagrams and circuit parameters) herein is for example only ; it is not guaranteed for volume production. HUA XUAN YANG ELECTRONICS believes information herein is accurate and reliable, but no guarantees are made or implied regarding its use or any infringements of intellectual property rights or other rights of third parties.
- Any and all information described or contained herein are subject to change without notice due to product/technology improvement, etc. When designing equipment, refer to the "Delivery Specification" for the HUA XUAN YANG ELECTRONICS product that you intend to use.