

智能功率模块口光耦
Intelligent Power Module
Optocoupler

AT4506-CuH-D

Product Data Sheet

AOTE DCC
RELEASE

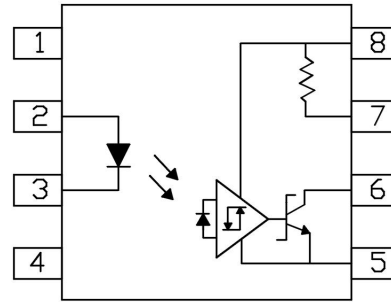
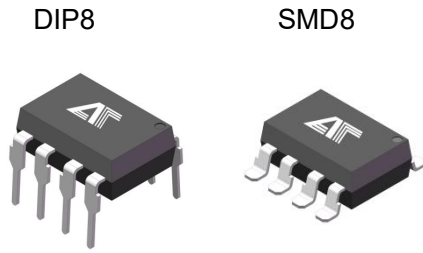

Pin Configuration
 1.NC
 2.Anode
 3.Cathode
 4.NC
 5.GND
 6.O
 7.VL
 8.VCC

◆ 封装逻辑原理图 Encapsulation logic schematic

AT4506 光耦采用高效光电转换技术，结合先进封装工艺，提供输入输出间的可靠隔离，支持DIP8-M、SMD8两种封装形式，适配多样化场景需求。

The AT4506 optocoupler adopts high-efficiency photoelectric conversion technology and advanced packaging processes, providing reliable input-output isolation. It supports Two package types (DIP8-M、SMD8) to meet diverse application requirements.

◆ 产品特征Product features

- 输入-输出隔离电压 $V_{ios}=5000V_{rms}$
Input output isolation voltage: $V_{ios}=5000V_{rms}$
- 15 kV/ μs 最小共模抑制;15kV/ μs minimum Common Mode Rejection
- 4.5V 至 30V 宽工作电压范围; 4.5V ~ 30V Wide operating VCC Range
- 爬电距离>7.0mm ; Creepage distance > 7.0mm;
- 输入-输出绝缘距离 >0.4mm ; Input-Output insulation Thickness > 0.4mm
- 防潮等级 class1; MSL class1
- 产品符合 ROHS、REACH 及 HF 等环保法规要求;
The products comply with ROHS, REACH and HF;

◆ 应用领域 Applications

- 交流/直流无刷电机驱动器 AC/DC brushless motor driver; 高压反馈干扰，确保电机调速精度与可靠性; High voltage feedback interference ensures the accuracy and reliability of motor speed regulation;
- 工业变频与逆变器Industrial frequency conversion and inverter; 缩短开关死区时间，优化IGBT/MOSFET的开关效率; Shorten the dead time of the switch, Optimizing the switching efficiency of IGBT/MOSFET
- 工业逆变器与USP电源Industrial inverters and USP power supplies;通过高共模瞬态抗扰度 (CMR15kV/ μs 抵御电压浪涌Resist voltage surges through high common mode transient immunity (CMR>15kV/ μs)
- 充电桩与车载充电器Charging stations and car chargers; 隔离车辆与充电设备的通信接口，防止地电位差导致信号失真; Communication interface between isolated vehicles and charging equipment, Prevent signal distortion caused by ground potential difference;



◆ 极限参数 Absolute Maximum Ratings (Ta =25°C)

参数 Parameter		符号 Symbol	额定值 Rating	单位 Unit
发射端 Input	平均输入电流 Average Forward Input Current	IF(AVG)	25	mA
	峰值正向输入电流 Peak Forward Input Current (50% duty cycle, ≤ 1 ms pulse width)	IF(PEAK)	1000	mA
	峰值瞬态输入电流 Peak Transient Input Current (≤1 μs pulse width, 300 pps)	IF(TRANS)	50	mA
	反向电压 Reverse Input Voltage	VR	5	V
接收端 output	平均输出电流 Average Output Current	IO(AVG)	15	mA
	电阻器电压 Resistor Voltage	V7	-0.5 ~VCC	V
	电源电压 Supply Voltage	VCC	-0.5 ~ 30	V
	输出电压 Output Voltage	VO	-0.5 ~ 30	V
	输出功率 Output Power Dissipation[3]	PO	100	mW
总功耗 Total Power Dissipation		Pt	145	mW
隔离电压 Isolation voltage		VISO	5000	Vrms
工作温度 Operating Temperature		Topr	-40 ~+100	°C
存储温度 Storage Temperature		Tstg	-55 ~+125	°C

◆ 推荐操作条件 Recommended Operating Conditions

参数 Parameter	符号 Symbol	最小值 Min	最大值 Max.	单位 Unit
电源电压 Supply Voltages	VDD	4.5	30	V
输出电压 Output Voltage	VO	0	30	V
开启电流 Forward Input Current (ON)	IF(ON)	10	20	mA
关断电压 Forward Input Voltage (OFF)	VF(OFF)	-5	0.8	V

◆ 产品特性参数 Product characteristic parameters (Ta = 25°C)

参数 Parameter	符号 Symbol	条件 Condition	最小 Min.	典型 Typ.	最大 Max.	单位 Unit
电流传输比 Current Transfer Ratio	CTR	IF = 10 mA, VO = 0.6 V	44	90	-	%
低电平输出电流 Low Level Output Current	IOL	IF = 10 mA, VO = 0.6 V	4.4	9.0	-	mA
低电平输出电压 Low Level Output Voltage	VOL	IO = 2.4 mA	-	0.17	0.6	V
输入阈值电流 Input Threshold Current	ITH	VO = 0.8 V, IO = 0.75 mA	-	0.96	5	mA
高电平输出电流 High Level Output Current	IOH	VF = 0.8 V	-	3	50	μA
高电平电源电流 High Level Supply Current	ICCH	VF = 0.8 V, VO = Open	-	0.7	1.3	mA
低电平电源电流 Low Level Supply Current	ICCL	IF = 10 mA, VO = Open	-	0.7	1.3	mA
输入正向电压 Input Forward Voltage	VF	IF = 10 mA	-	1.32	1.8	V
正向电压的温度系数 Temperature Coefficient of Forward Voltage	ΔVF/ΔTA	IF = 10 mA	-	-	-1.6	mV/°C
输入反向击穿电压 Input Reverse Breakdown Voltage	BVR	IR = 10 μA	5	-	-	V
输入电容 Input Capacitance	CIN	f = 1 MHz, VF = 0 V	-	60	-	pF
内置上拉电阻 Internal Pull-up Resistor	RL	TA = 25°C	14	20	25	kΩ
内置上拉电阻温度系数 Internal Pull-up Resistor Temperature Coefficient	ΔRL/ΔTA	-	-	0.014	-	kΩ/°C
输入输出电阻 Input-Output Resistance	RI-O	VI-O = 500 Vdc	-	10 ¹²	-	Ω
电容 (输入-输出) Capacitance (Input-Output)	CI-O	f = 1 MHz	-	0.6	-	pF

◆ 开关特性 Switching Specification(Ta =25°C , RL =20KΩ External)

参数 Parameter	符号 Symbol	条件 Condition	最小 Min.	典型 Typ.	最大 Max.	单位 Unit
逻辑低电平传输延迟 Propagation Delay Time to Logic Low at Output	TPHL	IF(on) = 10 mA, VF(off) = 0.8 V, VCC = 15.0 V,	30	250	400	ns
逻辑高电平传输延迟 Propagation Delay Time to High Output Level	TPLH	CL = 100 pF, VTHLH = 2.0 V, VTHHL = 1.5 V	270	400	550	
脉宽失真 Pulse Width Distortion	PWD	CL = 100 pF	-	150	450	
传输延迟差 Propagation Delay Difference Between Any 2 Parts	TPLH-TPHL	-	-150	150	450	
输出高电平共模抑制 Output High Level Common Mode Transient Immunity	CMH	VCM =1000V IF =0mA	15	30	-	kV/μs
输出低电平共模抑制 Output Low Level Common Mode Transient Immunity	CML	VCM =1000V IF =6.0mA	15	30	-	

开关特性 Switching Specification(Ta =25°C, RL =Internal Pull-up)

参数 Parameter	符号 Symbol	条件 Condition	最小 Min.	典型 Typ.	最大 Max.	单位 Unit
逻辑低电平传输延迟 Propagation Delay Time to Logic Low at Output	TPHL	IF(on)=10 mA, VF(off) = 0.8 V, VCC = 15.0 V, CL = 100 pF, VTHLH = 2.0 V, VTHHL = 1.5 V	20	300	400	ns
逻辑高电平传输延迟 Propagation Delay Time to High Output Level	TPLH		220	400	650	
脉宽失真 Pulse Width Distortion	PWD		-	100	500	
传输延迟差 Propagation Delay Difference Between Any 2 Parts	TPLH-TPHL		-150	100	500	
输出高电平共模抑制 Output High Level Common Mode Transient Immunity	CMH	VCM =1000V IF =0mA	-	30	-	kV/μs
输出低电平共模抑制 Output Low Level Common Mode Transient Immunity	CML	VCM =1000V IF =6.0mA	-	30	-	
电源抑制比 Power Supply Rejection	PSR	Square Wave,tRISE, tFALL> 5 ns, no bypass capacitors	-	1.0	-	Vp-p

◆ 电性特性曲线 Electrical characteristic curve (Ta = 25°C)

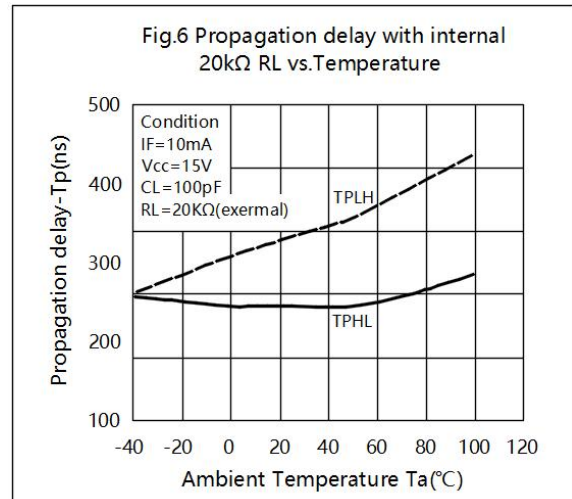
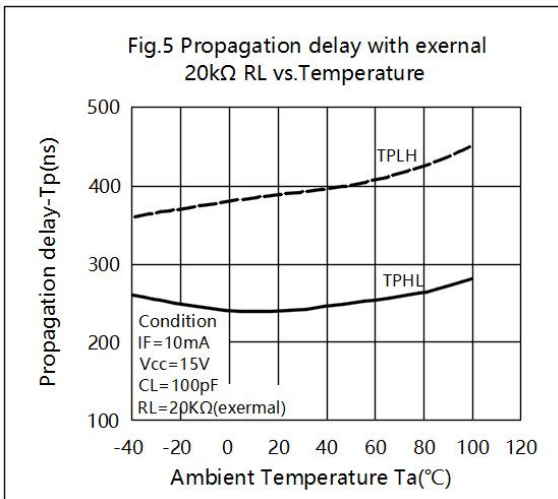
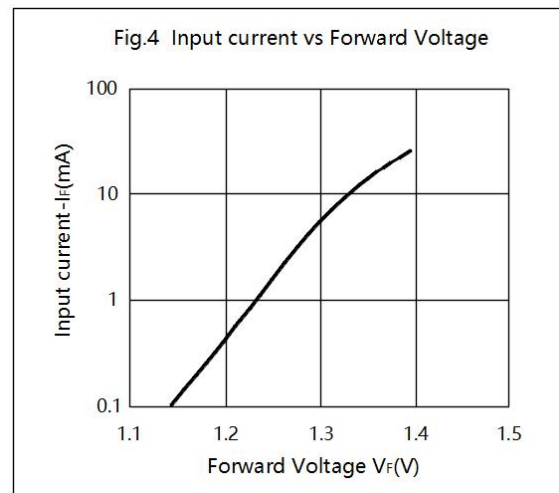
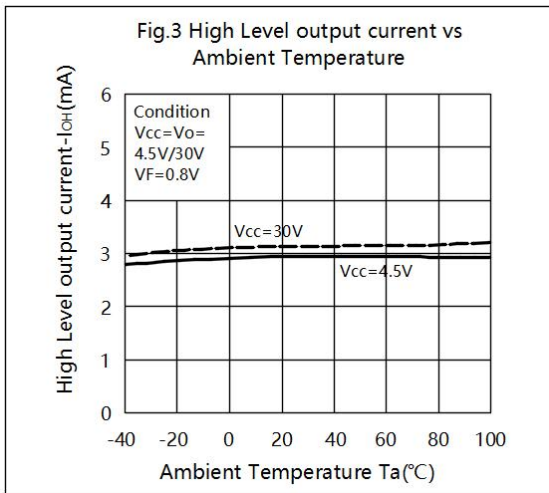
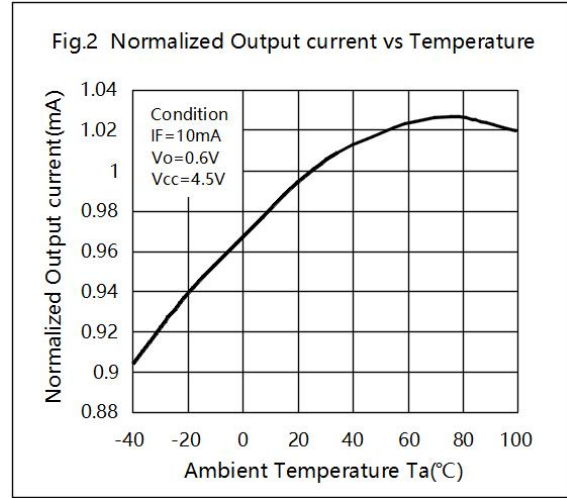
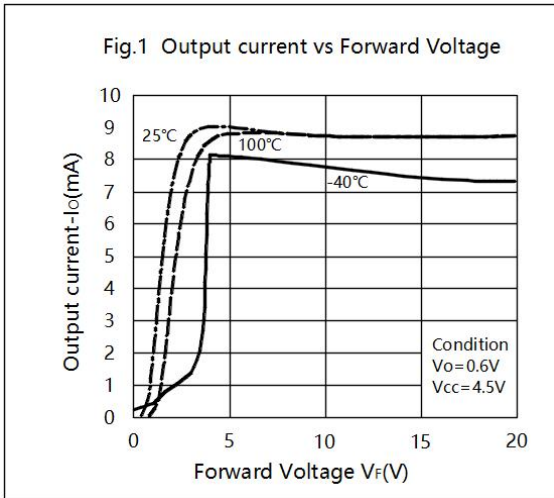

Fig.7 Propagation delay vs. Load resistance

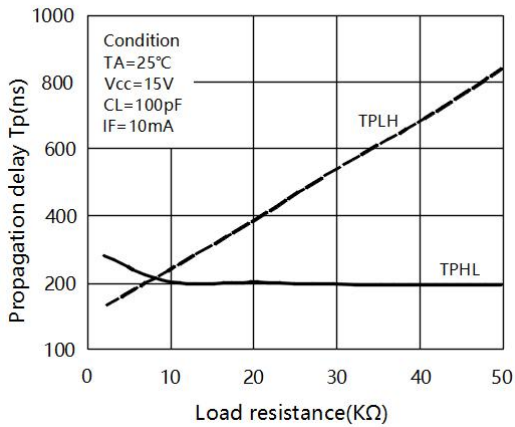

Fig.8 Propagation delay vs. Load capacitance

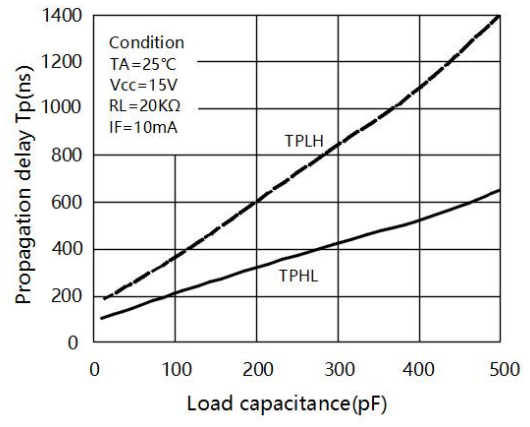

Fig.9 Propagation delay vs. supply voltage

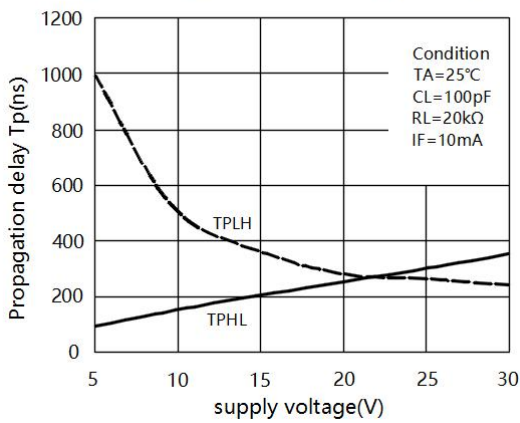
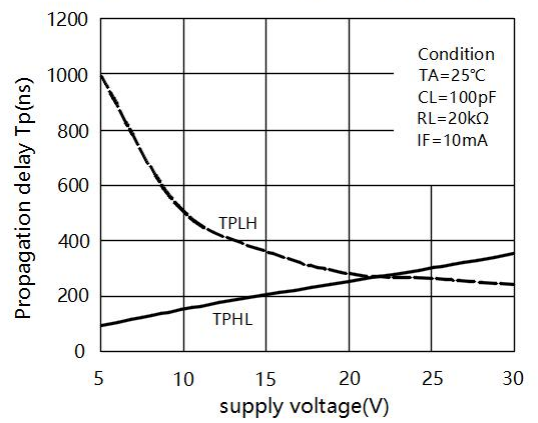
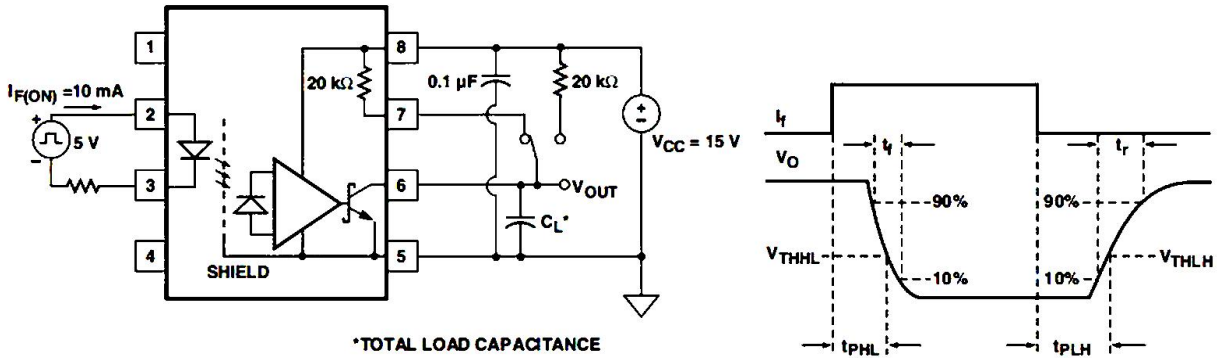

Fig.9 Propagation delay vs. supply voltage



◆ 延迟时间测试电路 Propagation Delay Time Test Circuit



◆ CMR 测试电路 Test Circuit for Common Mode Transient Immunity

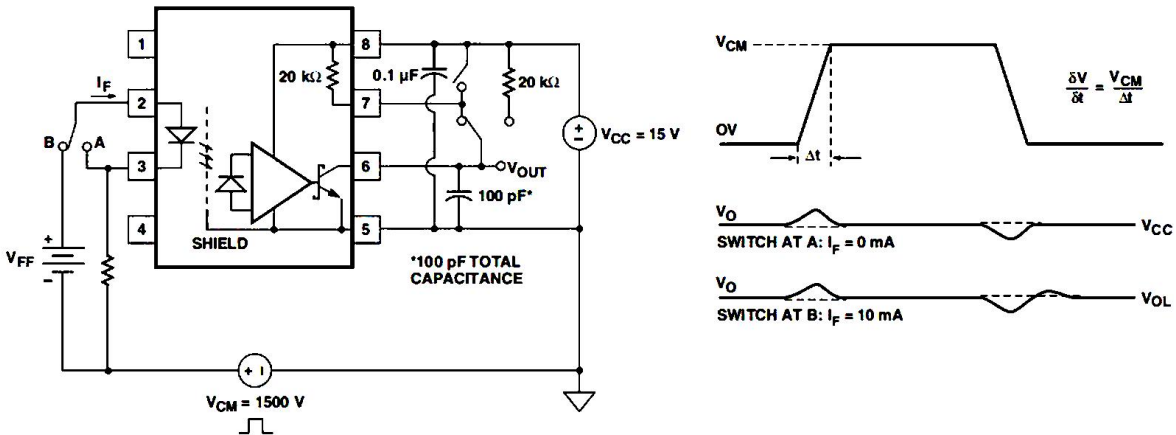

◆ 推荐 LED 驱动电路 Recommended LED Drive circuit

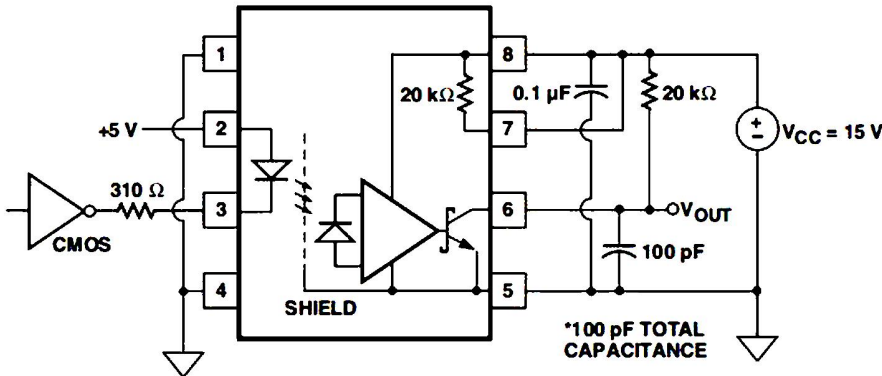

◆ 非屏蔽光耦合器的光耦器输入到输出电容模型

Optocoupler input to output capacitance model for unshielded optocouplers

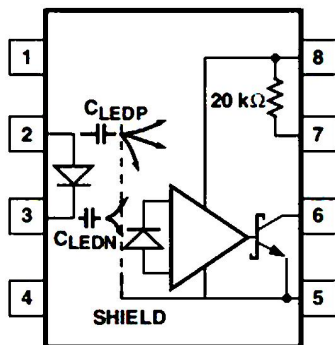

◆ 屏蔽光耦器的光耦输入输出电容模型

Optocoupler input to output capacitance model for shielded optocouplers

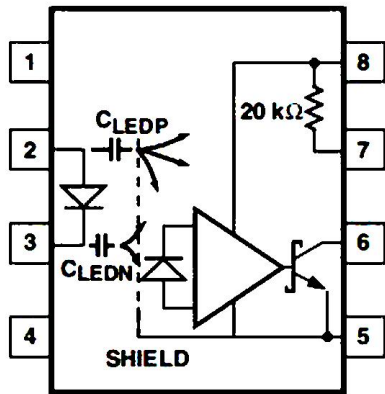

◆ 屏蔽光耦 LED 驱动电路与电阻连接的 LED 阳极 (不推荐)

LED drive circuit with resistor connected to LED anode (not recommended)

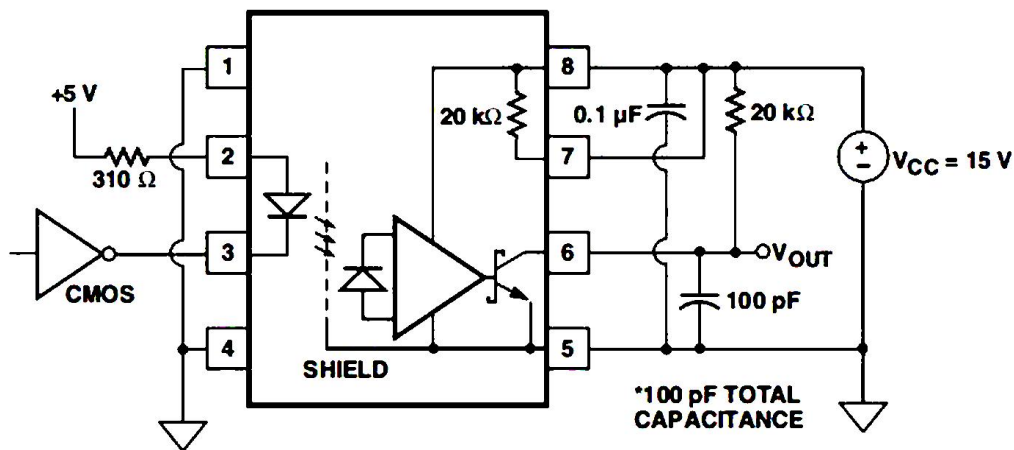

◆ 超高 CMR 推荐 LED 驱动电路

Recommended LED drive circuit for ultra high CMR

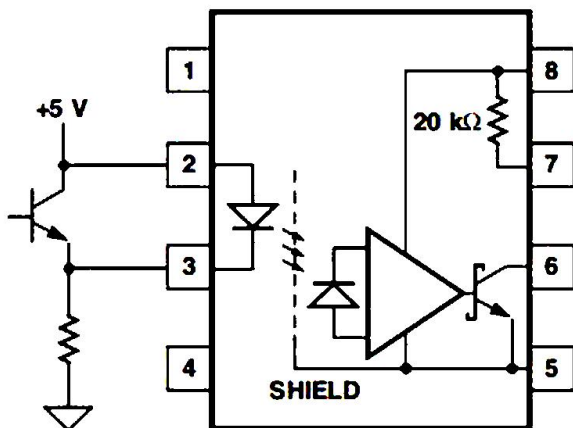

◆ 外形尺寸Overall dimension

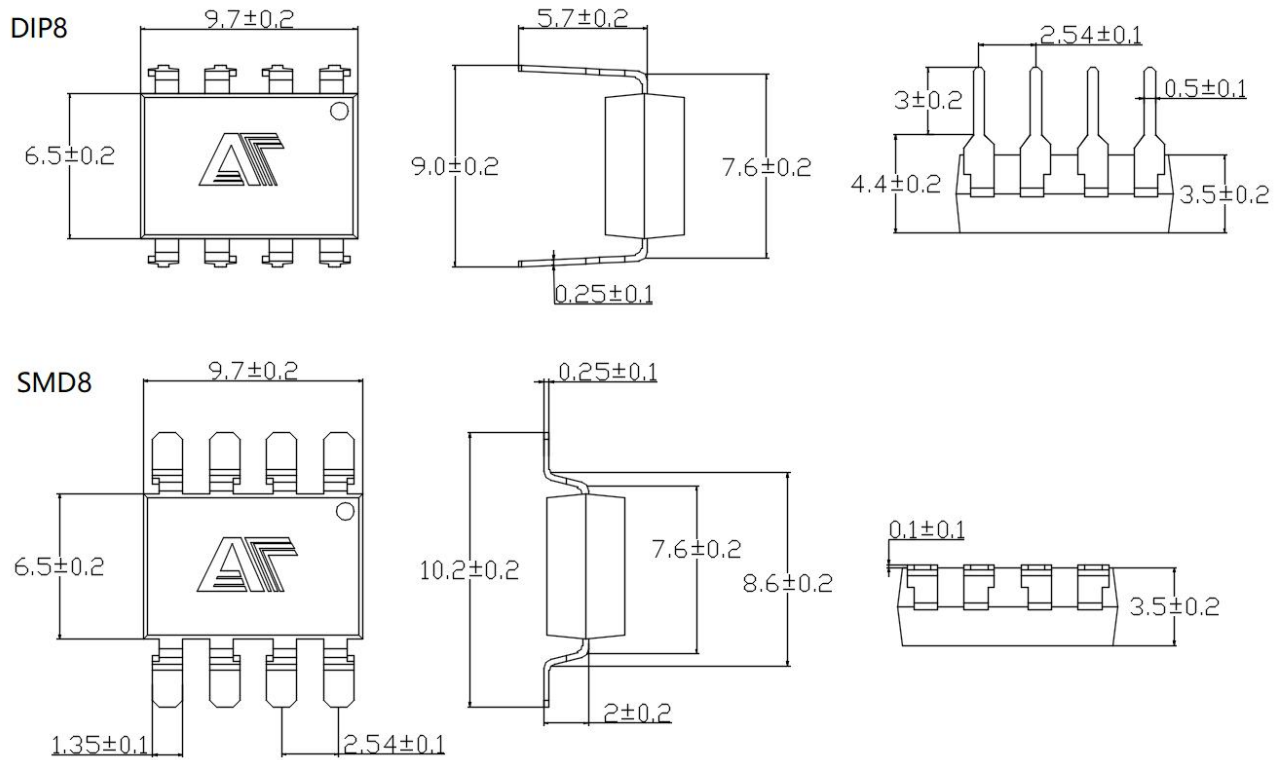

推荐焊盘:

Recommended

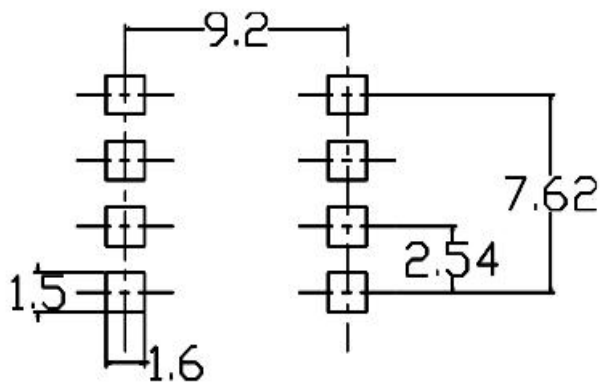



单位: mm

◆ 产品型号命名规则 Order code
AT 4506 - UN Y - W (V) (ZZ)

① ② ③ ④ ⑤ ⑥ ⑦

- ① 公司代码 Company Code (AT: 奥特 Aote)
- ② 产品系列 Product Series (4506)
- ③ 框架类型 Lead Frame (Cu: 铜框架 Copper, Fe: 铁框架 Ferrum)
- ④ 树脂类型 Epoxy Type (H: 无卤 Halogen-free)
- ⑤ 封装形式 Package (D:DIP, S:SMD)
- ⑥ 器件工作温度范围 Device Operating Temperature Range (特殊范围需填或者空白 Special Range need to be filled in or left blank)
- ⑦ 内部补充代码 Internal Supplementary Code (数字或者空白 Number or None)

◆ 印字信息 Marking Information

- 印字中 “” 为奥特品牌LOGO
“” denotes LOGO
- 印字中 “Y” 代表年份; A(2018),B(2019),C(2020)
“Y” denotes YEAR: A(2018), B(2019), C(2020)
- 印字中 “WW” 代表周号
“WW” denotes Week' s number
- 印字中 “E” 代表内部代码
“E” denotes Internal code
- 印字中的 “H” 代表无卤
“H” denotes Halogen-free

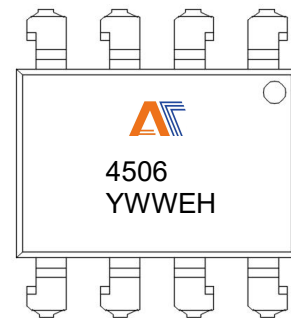

◆ 包装packing

封装形式	包装方式	盘数量	盒数量	箱数量	静电袋规格	盒规格	箱(双瓦楞)规格	备注
SMD8	卷盘 ($\phi 330$ mm蓝盘)	1000 只/盘	2 盘/盒	10 盒/箱	450*390*0.1mm	340*60*340 mm	620*360*365mm	首尾端空至少200mm
DIP8	管装 (500*12*11mm)	45 只/管	50 管/盒	10 盒/箱	不适用	525*128*56 mm	535*275*300mm	每管使用蓝白胶塞, 方向须一致
Package Type	Packing Form	Quantity per Reel	Quantity per Box	Quantity per Carton	Antistatic Bag Specification	Box Specification	Carton Specification	Note
SMD8	Reel ($\phi 330$ mm Blue)	1000 pcs/reel	2 reels/box	10 boxes/ctn	450*390*0.1mm	340*60*340 mm	620*360*365mm	Leave at least 200mm of blank space at both ends
DIP8	Tube (500*12*11mm)	45 pcs/tube	50 tubes/box	10 boxes/ctn	NA	525*128*56 mm	535*275*300mm	Use blue and white rubber plugs for each tube in the same direction

• 编带包装 Tape & Reel

- 1) 每卷数量: 2000 只;
Qty/reel: 2000 pcs;
- 2) 每箱数量: 40000 只;
Qty/ctn: 40000 pcs;
- 3) 内包装: 每盒 2 盘;
Inner packing: 2 reels/box;
- 4) 示意图 Schematic:

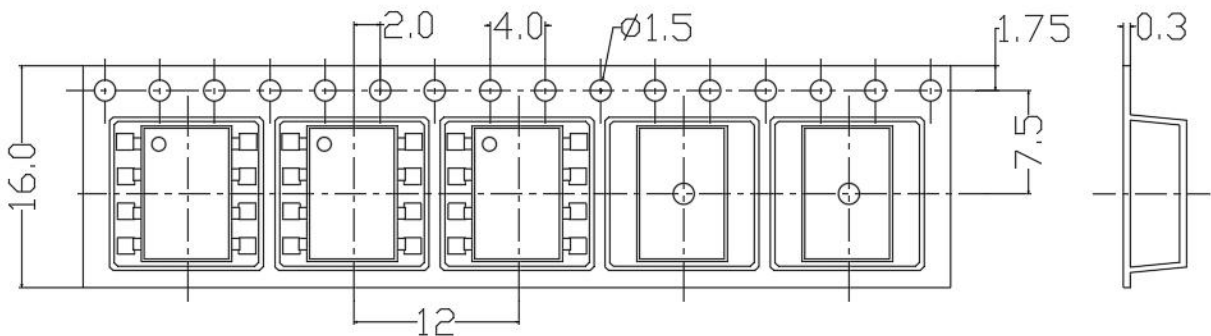
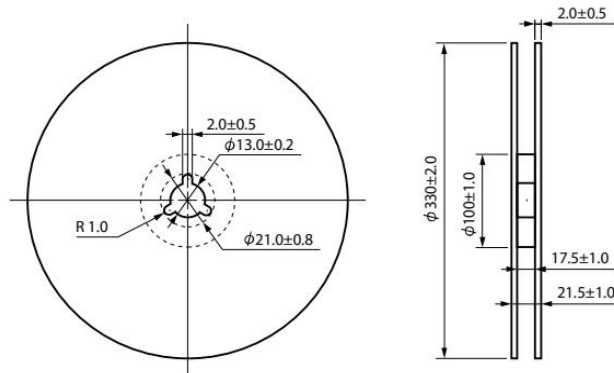

• 管条包装Tape&Tube

- 1) 每管数量: 45 只。
Qty/Tube : 45 pcs.
- 2) 每箱数量: 22500 只。
Qty/ctn: 22500 pcs.
- 3) 内包装: 每盒 50 管。
Inner packing: 50 Tube/box.
- 4) 示意图 Schematic

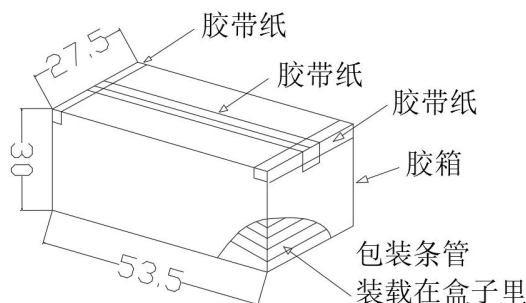

单位: mm

◆ 可靠性测试 Reliability Test Items And Conditions

实验项目 Test Items	参考标准 Reference	实验条件 Test Conditions	时间 Time	样品数 Quantity	判据 Criterion
可焊性 Solderability	JESD22-B102	Tsol= (245±5) °C, t=5s;	1 次1 times	22	0/22
耐焊接热 Resistance to Soldering Heat	JESD22-A106	Tsol= (260±5) °C, t=10s	3 次3 times	22	0/22
静电放电 ESD-HBM	JESD22-A114	Ta=25°C, HBM (2000V)	正反各 3 次 P&N 3 times	10	0/10
高温贮存 High emperature Storage	JESD22-A103	Ta=125°C	1000h	22	0/22
低温贮存 Low Temperature Storage	JESD22-A119	Ta= -55°C	1000h	22	0/22
冷热冲击 Thermal Shock	JESD22-A104	-55°C(15min)←→ 125°C(15min)	循环 300 次 300 cycles	22	0/22
常温寿命试验 Lifespan Test	JESD22-A108	Ta=25°C, IF=50mA , Vcc=5V	1000h	22	0/22
高温寿命试验 DC Operating Life	JESD22-A108	Ta=110°C, IF=20mA , Vcc=5V	1000h	76	0/76
高温高湿偏压 High Temperature High Humidity bias Voltage	JESD22-A101	Ta =85°C , RH=85% IF=0mA , VCE=64V	1000h	22	0/22
高温偏压 High Temperature bias Voltage	JESD22-A108	Ta =110°C , IF=0mA , VCE=80V	1000h	22	0/22
高压蒸汽试验 High pressure steam test	JESD22-A102	P=15PSIG , 121°C, 100%RH	96h	22	0/22

◆ **回流焊温度曲线图 Solder Reflow Profile**

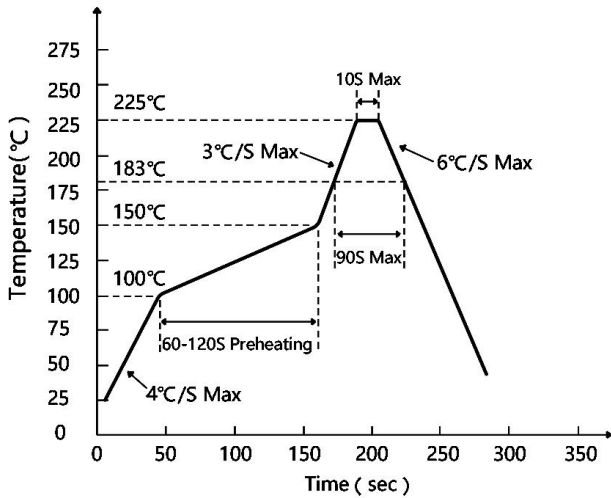

有铅制程 Lead Process

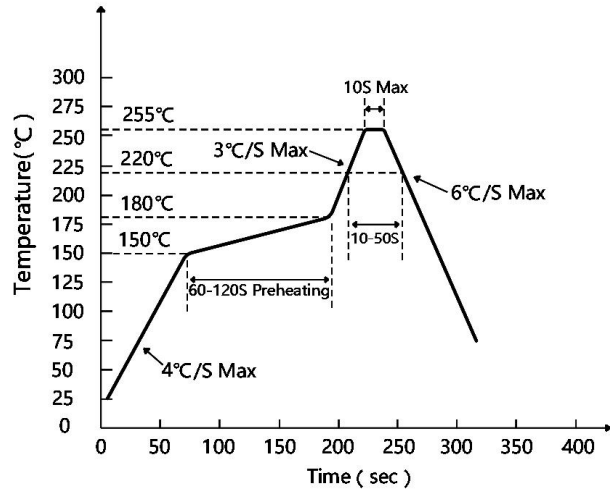

无铅制程 Lead Process

◆ **波峰焊温度曲线图 Wave Soldering Profile**

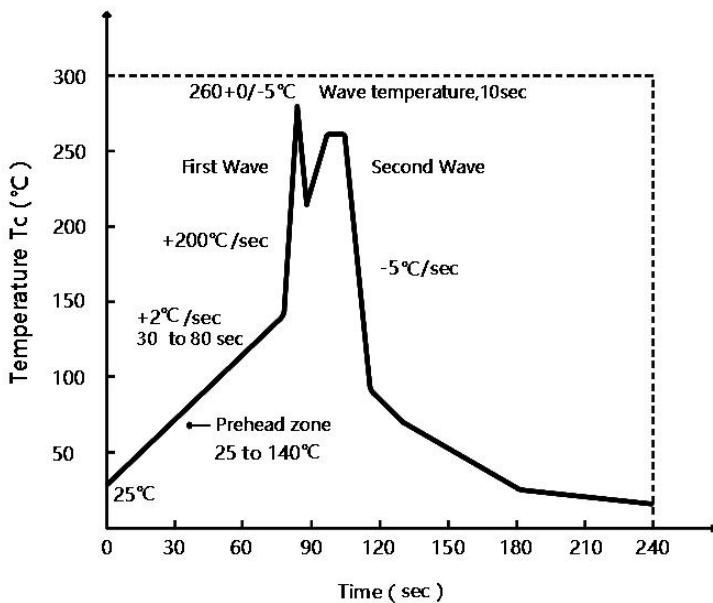

◆ **手工烙铁焊接 Soldering with hand soldering iron**

A. 手工烙铁焊仅用于产品返修或样品测试;

Hand soldering iron is only used for product rework or sample testing;

B. 手工烙铁焊要求: 温度 350°C ± 5°C, 时间 ≤ 3s.

Hand soldering iron requirements: Temperature: 350°C ± 5°C, within 3s.

◆ 注意 Attention

- 奥特半导体实施动态技术迭代机制，产品规格可能随工艺升级调整，最新技术参数以官网发布版本为准。

AOTE implements dynamic technical updates. Specifications are subject to change. Refer to the official website for the latest version.

- 用户需严格遵循本规格书限定的操作条件，因超范围使用（包括但不限于过载、高温、非兼容电路设计）导致的器件失效，不在质量保证范围内。

Users must strictly adhere to specified conditions. Failures caused by misuse (overload, high temperature, incompatible circuits) are excluded from warranty.

- 医疗设备、工业控制等关键场景应用前，需联系技术支持获取定制化验证方案。

Contact technical support for customized validation in critical applications (medical devices, industrial control).

- 本文档有效期至2025年12月31日，后续更新将通过官网公告推送。

This document is valid until Dec 31, 2025. Updates will be notified on the official website.

- 如需对技术参数或应用方案进行进一步确认，欢迎通过以下渠道获取官方支持：

For further clarification on technical specifications or application solutions, please contact us through official channels: