

WIRE, ELECTRICAL, RADIATION CROSSLINKED, MODIFIED FLUOROPOLYMER INSULATED,  
 TIN COATED COPPER, 150°C, 600 VOLT, LIGHTWEIGHT

The complete requirements for procuring the wire described herein shall consist of this document.

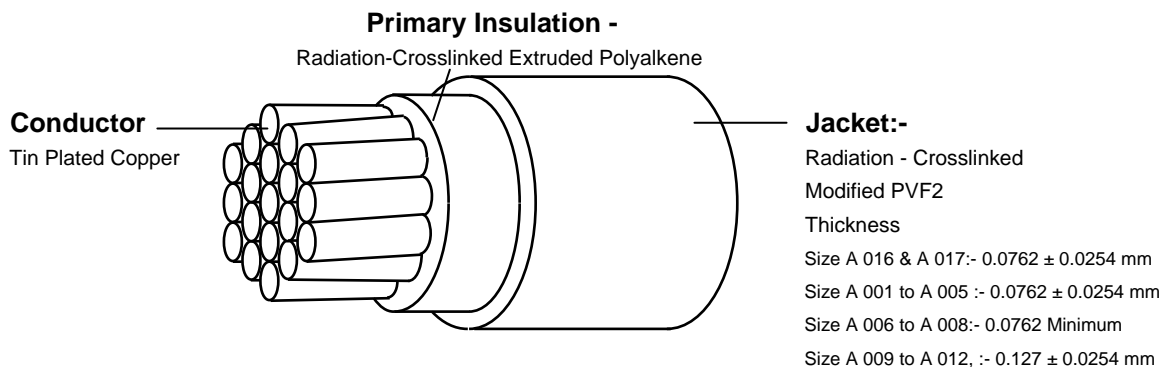

Part Description	Nominal Cross Sectional Area (mm <sup>2</sup> )	Conductor			FINISHED WIRE					Stock Number 6145-12-
		Stranding No./Diam. (mm)	Diameter (mm)		Maximum Resistance @ 20°C (ohms/km)	Diameter (mm)			Maximum Weight (kg/km)	
			Min.	Max.		Lower Spec Limit	Target	Upper Spec Limit		
VG 95218 T020 A 016	0.25	19/.127	0.58	0.61	86.00	1.003	1.016	1.041	2.99	165-2230
VG 95218 T020 A 001	0.40	19/.16	0.74	0.76	53.10	1.168	1.194	1.219	4.40	164-8663
VG 95218 T020 A 002	0.50	37/.127	0.83	0.86	42.30	1.270	1.295	1.320	5.47	306-2456
VG 95218 T020 A 003	0.60	37/.14	0.93	0.96	33.50	1.372	1.397	1.422	6.60	181-1850
VG 95218 T020 A 004	0.75	37/.16	1.03	1.08	26.60	1.499	1.524	1.549	8.25	187-8108
VG 95218 T020 A 005	1.00	37/.18	1.18	1.23	21.00	1.651	1.676	1.702	10.29	187-6676
VG 95218 T020 A 006	1.20	37/.20	1.34	1.37	16.40	1.829	1.854	1.880	12.84	187-6677
VG 95218 T020 A 007	1.50	37/.23	1.49	1.53	13.50	2.032	2.057	2.083	15.85	187-8109
VG 95218 T020 A 008	2.50	37/.287	1.85	1.89	8.20	2.489	2.540	2.591	24.08	187-8110
VG 95218 T020 A 017	3.00	37/.32	2.13	2.16	6.63	2.692	2.743	2.794	30.09	185-3573
VG 95218 T020 A 009	4.00	7X33X.16#	2.65	3.00	5.09	4.520	4.595	4.670	58.00	199-4671
VG 95218 T020 A 010	6.00	7X27X.21#	3.35	3.80	3.39	5.000	5.150	5.500	79.00	307-4348
VG 95218 T020 A 011	10.00	19X17X.21#	4.30	4.80	1.95	6.071	6.147	6.223	124.00	188-2429
VG 95218 T020 A 012	16.00	19X27X.21#	5.20	5.80	1.24	7.010	7.061	7.112	188.00	307-4349

# Indicates conductor stranding diameter shall be Maximum, otherwise shall be nominal

**COLOUR CODE:** All above products shall be White except where coloured components are defined within the issue in effect of VG95218 cable constructions that use Type 20 components. Coloured VG 95218 T020A components are strictly for VG released cable constructions only.

**NOTE:** Nato Stock Numbers (NSN) apply to white wire only.

**PERFORMANCE REQUIREMENTS :** Shall be tested to the issue in effect of WSD 955 and shall meet all the requirements of the issue in effect of VG 95218-20 (Type A).

**APPROVAL:** Electronic approval - no signatures will appear.

Tyco Electronics UK Ltd  
 Faraday Road  
 Dorcan  
 SWINDON  
 SN3 5HH  
 UK

Registration Number:  
 550926 London, England

This drawing and the information set forth hereon are the property of Tyco Electronics UK Ltd, and are to be held in trust and confidence. Publication, duplication, disclosure or use for any purpose not expressly authorised in writing by Tyco Electronics UK Ltd is prohibited.

This specification sheet takes precedence over documents referenced herein. As Tyco Electronics UK Ltd. reserve the right to make changes in construction without notice please contact Tyco Electronics UK Ltd to ensure that this document is the latest issue

Tel: 0800 267666  
 Fax: 01793 572516

Website: [www.tycoelectronics.com](http://www.tycoelectronics.com)  
 Email: [picuk@tycoelectronics.com](mailto:picuk@tycoelectronics.com)