



E-NETTR 10/100/1000Base-T DUAL Port Transformer Module

P/N: H5014L

- * Designed to meet IEEE802.3af requirement
- * Lead-Free & Designed to meet RoHS requirement
- * Designed to meet IR 255°C peak Requirement.
- * Operating temperature range: -40°C to +85°C
- * Storage temperature range:-40°Cto+85°C



Electrical Specifications@25° C

Part Number	Turn Ratio (±3%)	OCL(uH Min) @ 100KHz/0.1V with 8mADC Bias	L.L (uH Max)	C _{w/w} (pF Max)	DCR (Ω Max)	Hi-Pot (Vrms MIN)
H5014L	1CT:1CT	350	0.5	28	1.2	AC 1500/ 1mA

Continue

Part Number	Insertion Loss 0.3~100MHZ (dB Max)	Return Loss (dB Min)				Cross Talk (dB Min)		DCMR (dB Min)		
		0.3-30MH	60MHz	80MHz	100MHz	0.3-60MHz	60-100MHz	0.3-30MHz	60MHz	100MHz
H5014L	-1.1	-18	-14	-12	-10	-42	-35	-40	-35	-30

Mechanical

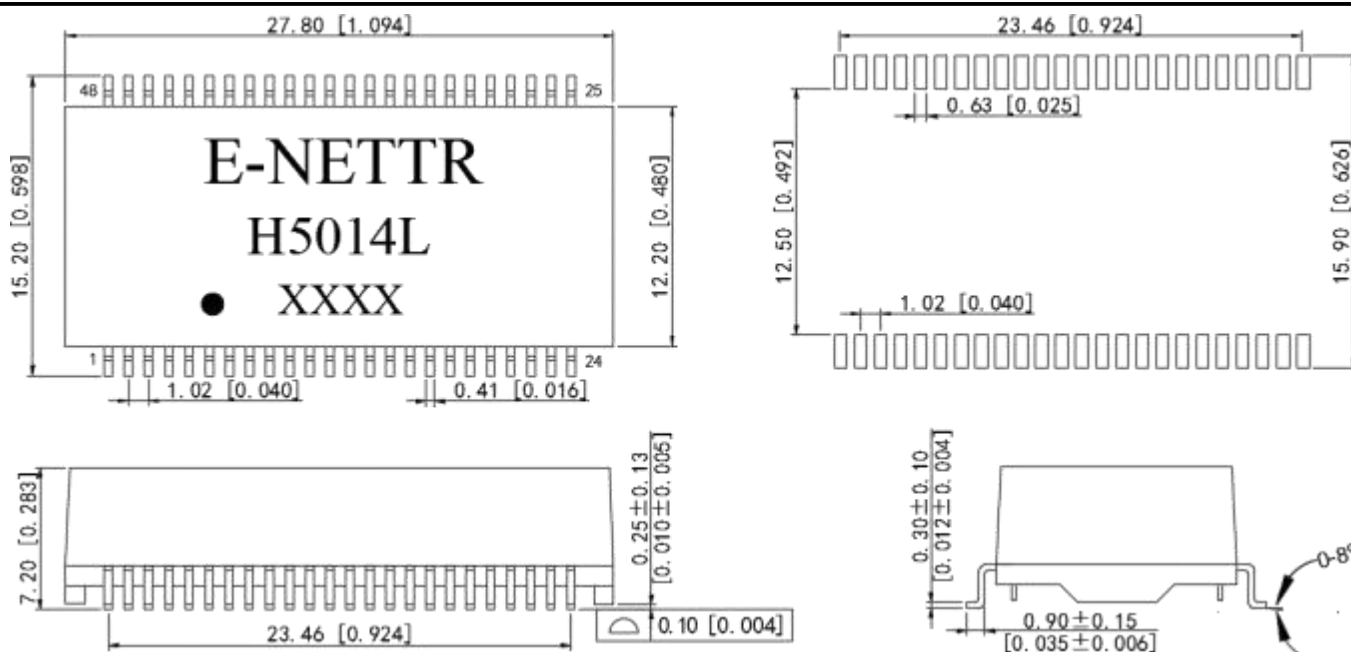

Unless:mm[inch] Tolerances: xx.xo± 0.25[0.010]
o.xx± 0.05[0.002]

Schematics

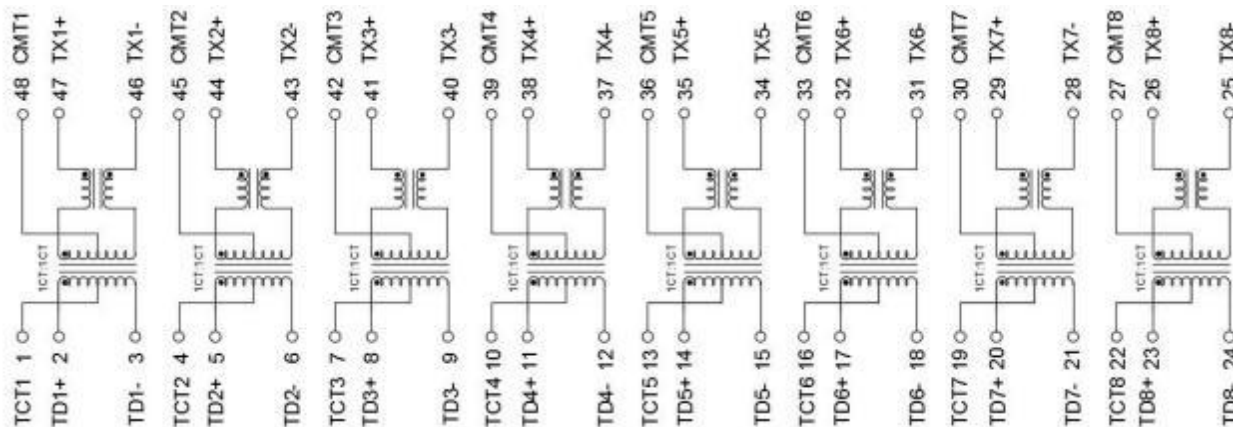

东莞市祥星电子有限公司

地址: 东莞市石碣镇横滘科技中路第三工业区 Miss xie:13549396638

TEL:0769-86384669

FAX:0769-81813600

Http://www.e-nettr.com

xingguang@e-nettr.com