

# AW3606A/AW3606B Synchronous Step-up Converter with Ultra Low Quiescent Current

## Features

- Ultra Low Quiescent Current:
- $I_q$  into VIN Pin: 200nA
- $I_q$  into VOUT Pin: 800nA
- Operating Input Voltage Range: 0.9V~5.2V
- Adjustable Output Voltage from 2.5V~5.5V
- $I_{Load} \geq 0.5A$  at  $V_{OUT}=5V$ ,  $V_{IN} \geq 3V$
- Operation Mode: Boost Mode, Down Mode, Pass-through Mode
- True Cutoff VIN to VOUT path During Shutdown
- Up to 93% Efficiency at 10mA~300mA Current Load
- Up to 80% Efficiency at 100 $\mu$ A Current Load for AW3606B
- Build-in OVP, OTP, UVLO Protection
- DFN 2mm x 2mm x 0.55mm-8L Package

## Applications

Portable Products

Battery Powered Systems

Wearable Applications

Low Power Wireless Applications

Optical Heart Rate Monitor LED Bias

## General Description

The AW3606A/AW3606B is a high efficiency synchronous step-up converter with ultra-low quiescent current down to 1 $\mu$ A, it is optimized for battery-powered applications, such as alkaline battery, coin-cell battery, Li-ion or Li-Polymer battery, that requires long battery life and tiny solution size.

The AW3606A/AW3606B uses a hysteretic current mode control scheme with typical 1.4A peak switch current limit when VOUT voltage exceed 2.5V. It consumes 1 $\mu$ A quiescent current under light load condition and can achieve up to 80% efficiency at 100 $\mu$ A load with AW3606B. It supports up to 500mA output current when input voltage is above 3V, and achieve up to 93% efficiency at 200mA load.

The AW3606A/AW3606B operates in down mode and pass-through mode when input voltage is close to or higher than output voltage. In the down mode, the AW3606A/AW3606B will continue to regulate the output voltage even when the input voltage exceeds the output voltage. When  $V_{IN} > V_{OUT} + 0.37V$ , It enters pass-through mode and the device stops switching. The rectifying PMOS constantly turns on and low-side switch constantly turns off.

The AW3606A/AW3606B build-in true shutdown function when it is disabled, which isolates the load from the input to reduce the current consumption. Also, the AW3606A/AW3606B integrates OVP, OTP, UVLO protections.

The AW3606A has adjustable output voltage. The AW3606B has a 5V fixed output voltage. The AW3606A/AW3606B is available in a tiny DFN 8pin package.

## Typical Application Circuit

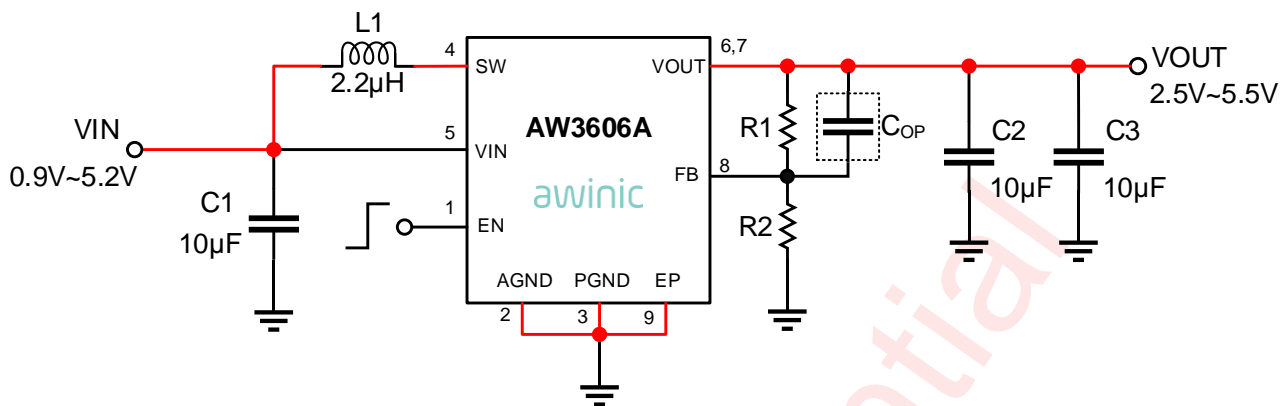

Typical Application Circuit of AW3606A

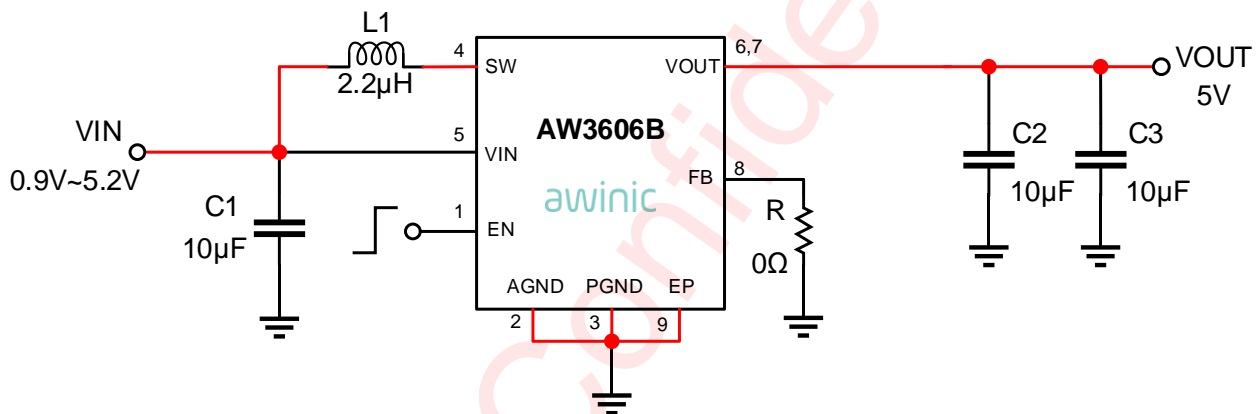

Typical Application Circuit of AW3606B

For best output and input voltage filtering, low ESR X5R or X7R ceramic capacitors are recommended.

For AW3606A, the FB pin should be connected to the resistance divider, and the VOUT can be set to  $V_{FB}(R1 + R2)/R2$ . The FB pin cannot be connected to the GND.

For AW3606A, a  $C_{OP}$  is recommended between FB and OUT pin to optimize the load transient response performance.

For AW3606B, the FB pin should be connected to the GND.

## Device Comparison Table

PART No.	OUTPUT VOLTAGE
AW3606A	Adjustable
AW3606B	5.0 V

## Pin Configuration And Top Mark

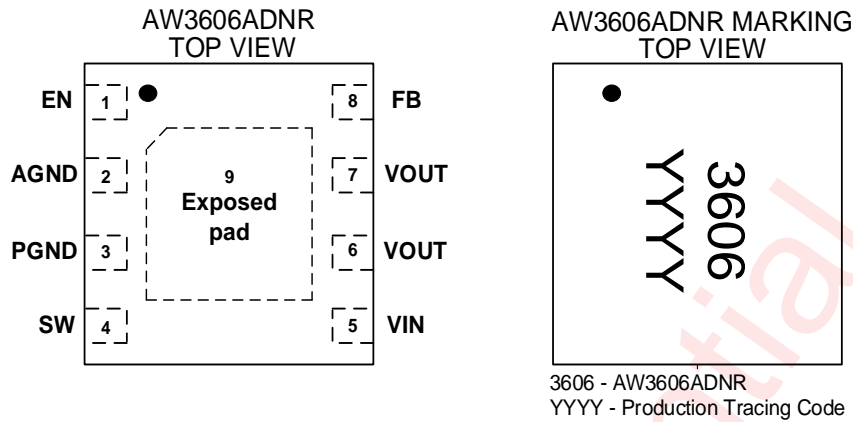

**Pin Configuration and Top Mark of AW3606A**

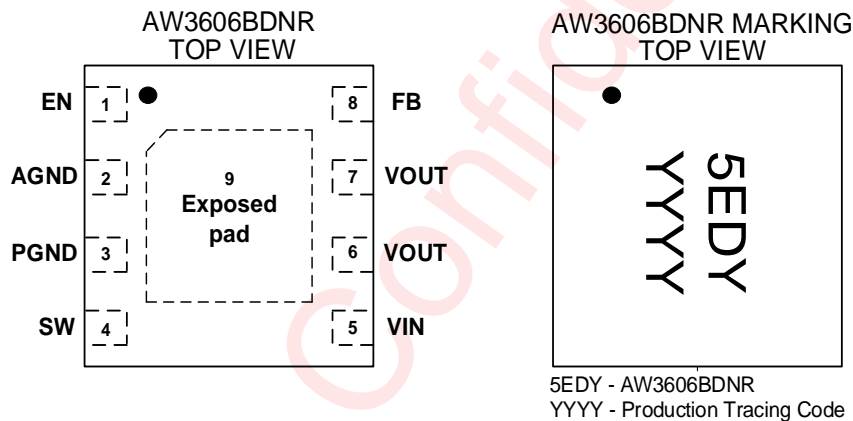

**Pin Configuration and Top Mark of AW3606B**

## Pin Definition

Pin No.	NAME	DESCRIPTION
1	EN	Enable Logic Input. Logic high voltage enables the device; logic low voltage disables the device. Do not leave it floating.
2	AGND	Analog Ground. Should be connected to PGND.
3	PGND	Power Ground. This is the power return terminal for the IC, C <sub>OUT</sub> capacitor should be returned with the shortest path possible to this pin.
4	SW	Switch Pin of the Converter. It is connected to the inductor.
5	VIN	Power Supply Input.
6, 7	VOUT	Boost Converter Output.
8	FB	Voltage Feedback of Adjustable Output Voltage for AW3606A. Connect to the center tap of a resistor divider to program the output voltage. Connect to the GND is forbidden. Connect to the GND pin for AW3606B.
9	Exposed Pad	Should be connected to AGND and PGND.

Functional Block Diagram

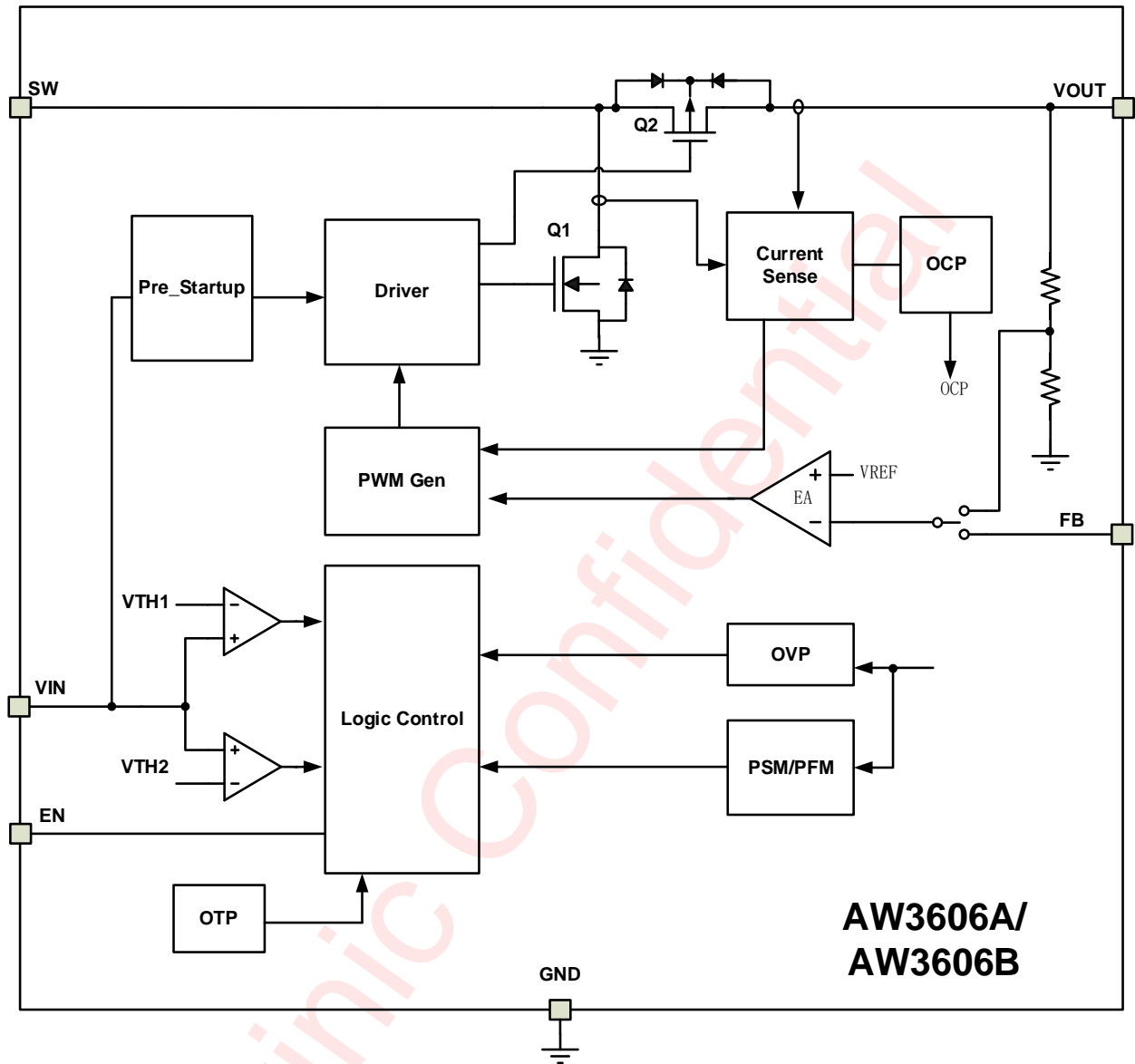

Functional Block Diagram

## Ordering Information

Part Number	Temperature	Package	Marking	Moisture Sensitivity Level	Environmental Information	Delivery Form
AW3606ADNR	-40°C ~ 85°C	DFN 2mm x 2mm x 0.55mm-8L	3606	MSL1	RoHS+HF	3000 units/ Tape and Reel
AW3606BDNR	-40°C ~ 85°C	DFN 2mm x 2mm x 0.55mm-8L	5EDY	MSL1	RoHS+HF	3000 units/ Tape and Reel

awinic Confidential

## Absolute Maximum Ratings<sup>(NOTE1)</sup>

PARAMETERS		RANGE
Input voltage range	V <sub>IN</sub> , FB, EN	-0.3V to 6V
Output voltage range	SW, V <sub>OUT</sub>	-0.3V to 6V
Operating free-air temperature range		-40°C to 85°C
Maximum operating junction temperature T <sub>JMAX</sub>		150°C
Storage temperature T <sub>STG</sub>		-65°C to 150°C
Lead temperature (soldering 10 seconds)		260°C
ESD(Including CDM HBM) <sup>(NOTE 2)</sup>		
HBM		±2kV
CDM		±1.5kV
Latch-Up		
Test condition: JESD78E		+IT: 200mA -IT: -200mA

NOTE1: Conditions out of those ranges listed in "absolute maximum ratings" may cause permanent damages to the device. In spite of the limits above, functional operation conditions of the device should within the ranges listed in "recommended operating conditions". Exposure to absolute-maximum-rated conditions for prolonged periods may affect device reliability.

NOTE2: The human body model is a 100pF capacitor discharged through a 1.5kΩ resistor into each pin. Test method: ESDA/JEDEC JS-001

## Thermal Information

PARAMETERS	DFN	UNIT
Junction-to-ambient thermal resistance R <sub>θJA</sub>	71.36	°C/W
Junction-to-top characterization parameter Ψ <sub>JT</sub>	2.91	°C/W
Junction-to-board characterization parameter Ψ <sub>JB</sub>	31.25	°C/W

## Recommended Operating Conditions

PARAMETERS	MIN	NORM	MAX	UNIT
Input Voltage Range V <sub>IN</sub>	0.9		5.2	V
Output Voltage Range V <sub>OUT</sub>	2.5		5.5	V
Inductor L	0.7	2.2	2.8	μH
Input Capacitor C <sub>IN</sub>	1.0	10		μF
Output Capacitor C <sub>OUT</sub>	10	20	100	μF

## Electrical Characteristics

$T_A = -40^{\circ}\text{C}$  to  $85^{\circ}\text{C}$  and  $V_{IN} = 0.9\text{ V}$  to  $5.2\text{ V}$ . Typical values are at  $V_{IN} = 3.7\text{ V}$ ,  $T_A = 25^{\circ}\text{C}$ , unless otherwise noted.

PARAMETER		TEST CONDITION	MIN	TYP	MAX	UNIT
<b>POWER SUPPLY</b>						
$V_{IN}$	UVLO threshold voltage	$V_{IN}$ rising		0.7		V
	Hysteresis for UVLO			0.2		V
	Input Voltage Range		0.9		5.2	V
$I_Q$	Quiescent Current into $V_{IN}$ pin	EN=High, No load, no switching		0.35	0.6	$\mu\text{A}$
	Quiescent Current into $V_{OUT}$ pin	EN=High, No load, no switching		0.9	3	$\mu\text{A}$
$I_{SD}$	Shutdown Current into $V_{in}$ pin	IC disabled, $V_{IN} = 3.7\text{ V}$ , $V_{OUT} = 0\text{ V}$ , $T_A = -40^{\circ}\text{C}$ to $85^{\circ}\text{C}$		0.2	1.8	$\mu\text{A}$
<b>OUTPUT</b>						
$V_{OUT}$	Output Voltage Range		2.5		5.5	V
Output accuracy		AW3606B, $V_{IN} < V_{OUT}$ , PWM mode, $I_{load}=50\text{mA}$	4.90	5.00	5.10	V
		AW3606B, $V_{IN} < V_{OUT}$ , PFM mode $I_{load}=0$		5.10		
$V_{REF}$	Feedback reference voltage	$V_{IN} < V_{OUT}$ , PWM mode	1.01	1.03	1.05	V
		$V_{IN} < V_{OUT}$ , PFM mode	1.02	1.05	1.08	
$V_{OVP}$	Output overvoltage protection threshold	$V_{OUT}$ rising	5.6	5.8	6.0	V
	OVP hysteresis			100	200	mV
$I_{FB\_LKG}$	Leakage current into FB pin			10	100	nA
<b>POWER SWITCH</b>						
$R_{DS(on)\_LS}$	Low side switch on resistance	$V_{OUT}=5.0\text{V}$		190		m $\Omega$
		$V_{OUT}=3.3\text{V}$		240		
$R_{DS(on)\_HS}$	Rectifier on resistance	$V_{OUT}=5.0\text{V}$		280		m $\Omega$
		$V_{OUT}=3.3\text{V}$		350		
$\Delta I_L$	Inductor current ripple	$V_{OUT}=5\text{V}$ , Guarantee by design		300		mA
$I_{LIM}$	Peak Current limit threshold	$V_{OUT} \geq 2.5\text{ V}$ , boost operation		1.4		A
		$V_{OUT} < 2.5\text{ V}$ , boost operation		0.75		
$I_{SW\_LKG}$	Leakage current into SW pin (from SW pin to GND)	$V_{SW} = 5.0\text{ V}$ , no switch			1	$\mu\text{A}$
<b>CONTROL LOGIC</b>						

PARAMETER		TEST CONDITION	MIN	TYP	MAX	UNIT
V <sub>IL</sub>	EN input low voltage threshold	V <sub>IN</sub> ≤ 1.5 V	0.2×V <sub>IN</sub>			V
V <sub>IH</sub>	EN input high voltage threshold	V <sub>IN</sub> ≤ 1.5 V			0.8×V <sub>IN</sub>	
V <sub>IL</sub>	EN input low voltage threshold	V <sub>IN</sub> > 1.5V	0.3			V
V <sub>IH</sub>	EN input high voltage threshold	V <sub>IN</sub> > 1.5V			0.9	
I <sub>EN_LKG</sub>	Leakage current into EN pin	V <sub>EN</sub> = 5.0 V			300	nA
Overtemperature protection				150		°C
Overtemperature hysteresis				25		

## Typical Characteristics

$T_A=25^{\circ}\text{C}$ ,  $C_{IN} = 10\mu\text{F}$ ,  $C_{OUT} = 20\mu\text{F}$ ,  $V_{IN}=3.7\text{V}$ , unless otherwise noted.

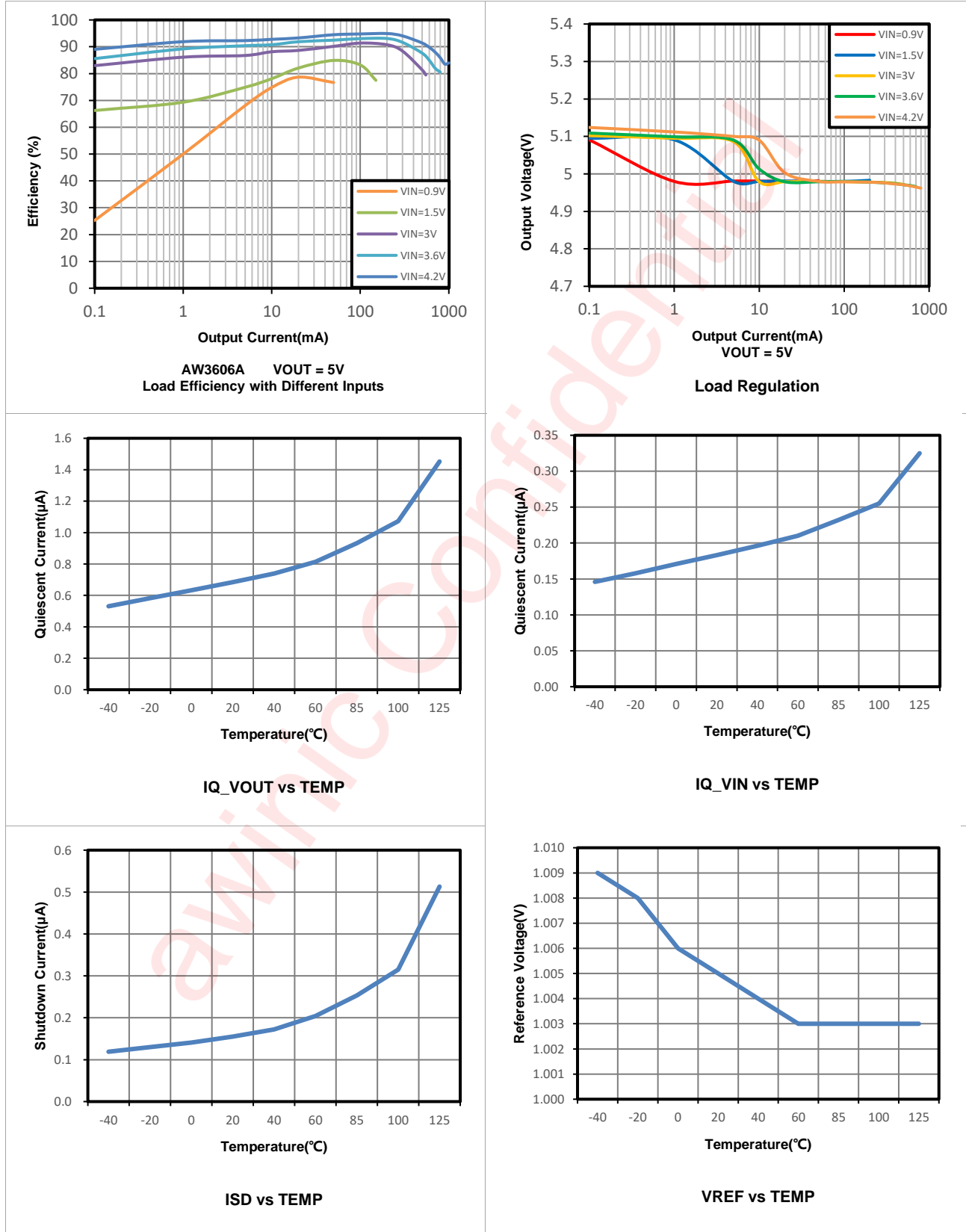

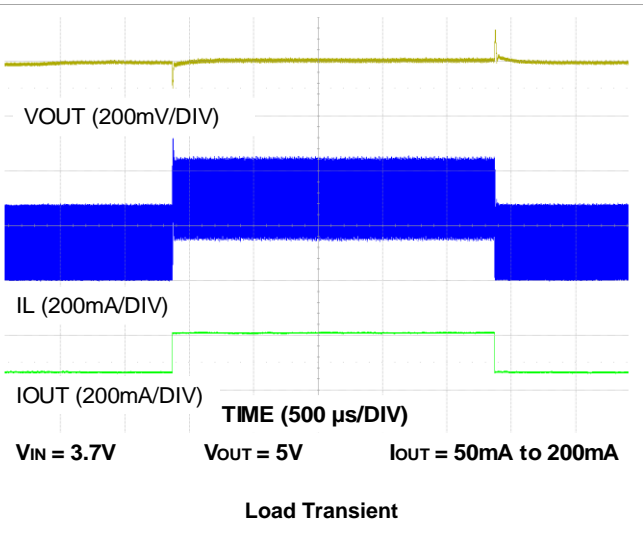
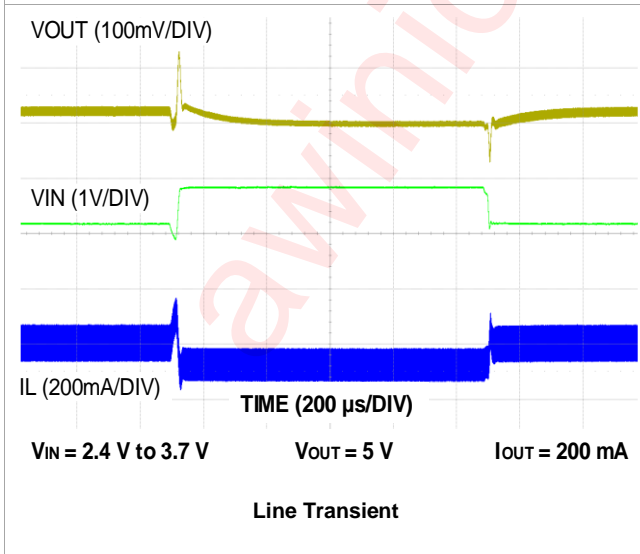
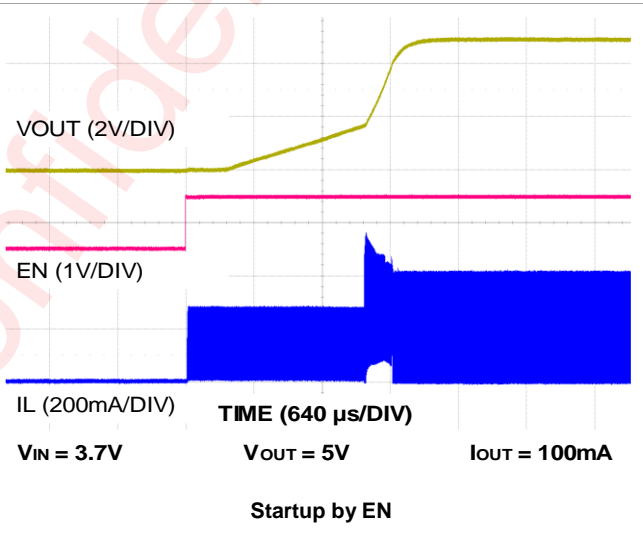
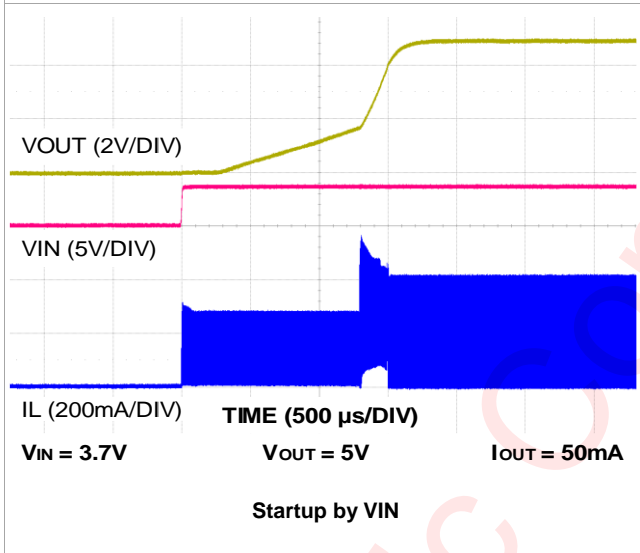
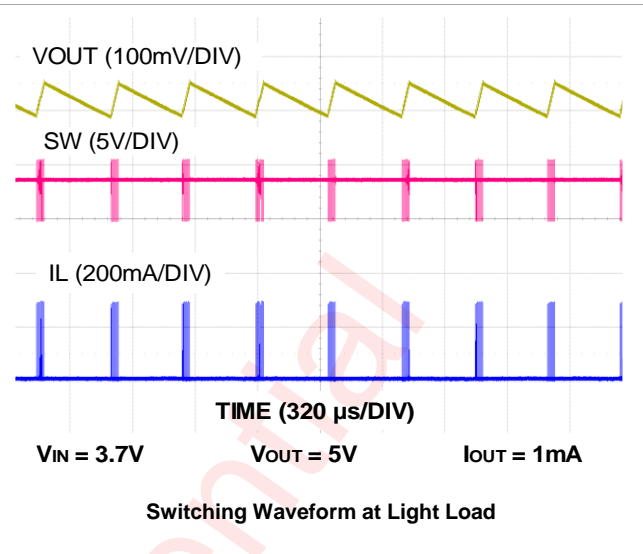
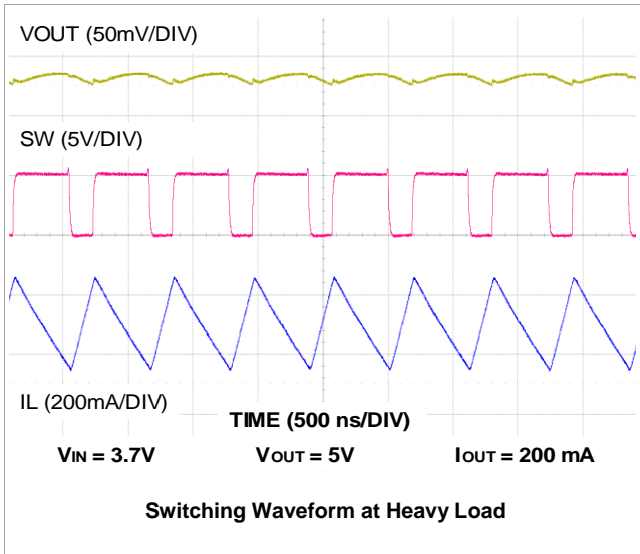

## Detailed Functional Description

The AW3606A/AW3606B is a high efficiency synchronous step-up converter with ultra-low quiescent current down to 1 $\mu$ A, it is optimized for battery-powered applications, such as alkaline battery, coin-cell battery, Li-ion or Li-Polymer battery, that requires long battery life and tiny solution size. The AW3606A can work with an input voltage as low as 0.9V to provide an output voltage from 2.5V to 5.5V.

The AW3606A/AW3606B uses a hysteretic current mode control scheme with typical 1.4A peak switch current limit when the output voltage is above 2.5V. When the AW3606A/AW3606B shuts down, the output is completely isolated from the input voltage, allowing the output to draw less than 0.2 $\mu$ A in shutdown mode. The AW3606A/AW3606B works in Down Mode and Pass-Through operation when input voltage is close to or higher than the output voltage. By adding a resistor divider at FB pin, the device can be set to any voltage level for flexible applications.

### Boost Controller Operation

The AW3606A/AW3606B boost converter is controlled by a hysteretic current mode controller. There are three modes of operation depending on the output load. If the required average input current is lower than the average inductor current defined by this constant ripple, the converter goes into discontinuous current operation. In this operation, it keeps the efficiency high under light load condition. If the load current is reduced further, the boost converter enters into Power save Mode(PSM). In PSM mode, the boost converter ramps up the output voltage with several switching cycles until the output voltage exceeding the setting threshold, the device stops switching and goes into a sleep status. In sleep status, the device consumes less quiescent current. If the load current increases and output voltage is below the setting threshold. It exits the PSM mode and enters into continuous current operation. In this mode, the controller keeps the inductor ripple current at almost 300mA. The input voltage, output voltage and inductor value affect the rising and falling slopes of inductor ripple current.

The output voltage VOUT is detected via an external feedback network which is connected to the voltage error amplifier. The voltage error amplifier compares this feedback voltage to the internal voltage reference and adjusts the output voltage at the target.

### Under-Voltage Lockout

To avoid abnormal state of the device at low input voltage, under voltage lockout is implemented that shuts down the converter when input voltage lower than 0.5V. The device be enabled again until the input voltage goes up to 0.7V. A hysteresis of 200mV is added to shut down the converter when the input voltage is between 0.5V and 0.7V.

### Enable and Disable

The AW3606A/AW3606B operates when the input voltage is above UVLO rising threshold and the EN is high. In shutdown mode with a low EN voltage, the device stops switching and the rectifying PMOS turns off as well. This isolates the load from the input, so that the output voltage can drop below the input voltage during shutdown. In shutdown mode, input current is less than 0.5 $\mu$ A.

### Soft Start

The internal Enable signal is high when the input voltage is above UVLO rising threshold, the device begins to startup. There are three steps for start-up. Firstly, VOUT is below 1.6V, the device operates at the boundary of DCM(Discontinuous Conduction Mode) and CCM(Continuous Conduction Mode), and the inductor current is limited to about 200mA in this mode. When the output voltage rises to about 1.6V, the device switches to close-

loop work mode with hysteretic current mode operation. The second stage, the inductor peak current is gradually increasing to  $0.7 \cdot I_{LIM}$  within  $500\mu s$ . The soft start function reduces the inrush current during startup. Finally, after  $V_{OUT}$  reaches the target value, soft start stage ends and the peak current is determined by the output of an internal error amplifier which compares the feedback of the output voltage and the internal reference voltage.

The AW3606A/AW3606B is able to start up with 0.9V input voltage with larger than  $3k\Omega$  load. If the load is too heavy, the output voltage can't rise to above 1.6V. The AW3606A/AW3606B will stay in pre-soft start procedure until the output voltage is increased or the load current is reduced. The startup time depends on input voltage and load current.

### Current Limit Operation

Current limit operation circuit senses the inductor current cycle-cycle. If the diagnostic circuit detects the inductor peak current exceeding the current limit threshold, the main switch turns off so as to stop further increase of the input current. In this condition the output voltage will decrease until the power balance between input and output is achieved. If the device goes into the down mode, the peak current is still limited by  $I_{LIM}$  cycle-by-cycle. If the output drops below 1.6V, the AW3606A/AW3606B enters into startup process and limits the switch current to about 200mA. If the device goes into the pass-through operation, current limit function is not enabled.

### Output Short-to-Ground Protection

In the event of a short-to-ground, the device first turns off the MOS when the sensed current reaches the current limit, inductor peak current is limited at 200mA. Once the short circuit is released, the AW3606A/AW3606B begins to soft start and regulates the output voltage.

### Over-Voltage Protection

AW3606A/AW3606B features over-voltage protection(OVP) for maximum safety. When the output voltage of the AW3606A/AW3606B exceeds the OVP threshold of 5.8V, the device stops switching. The device will start operating again until the output voltage falling to 5.7V.

### Down Mode and Pass-Through Mode

The AW3606A/AW3606B works in down mode or pass-through mode when  $V_{IN}$  is close to  $V_{OUT}$ . With  $V_{IN}$  raising, the AW3606A/AW3606B automatically switches from boost mode to down mode if  $V_{IN}$  goes above the  $V_{OUT}-50mV$ . It stays in down mode until  $V_{IN} > V_{OUT} + 0.37V$  and then goes automatically into pass-through mode. During the pass-through mode, output voltage follows input voltage. The AW3606A/AW3606B switches from pass-through mode to down mode when  $V_{IN}$  ramps down to 101% of the target output voltage. It exits down mode when  $V_{IN} < V_{OUT} - 100mV$ , returning to boost operation.

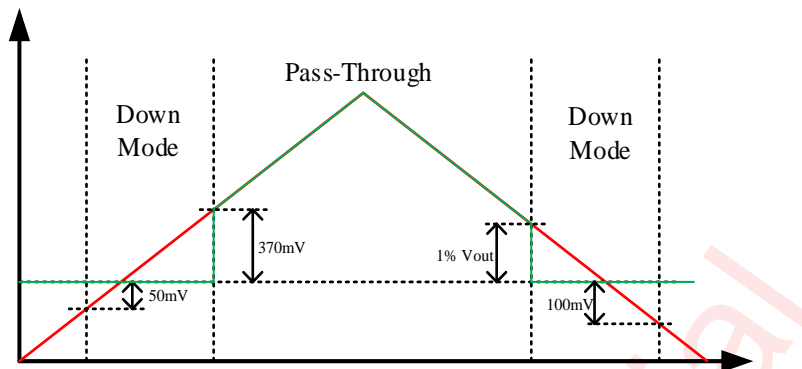

**Down Mode and Pass-Through Mode**

In the down mode, the AW3606A/AW3606B will continue to regulate the output voltage even when the input voltage exceeds the output voltage. This is achieved by terminating the switching at the synchronous PMOS and applying a modulated voltage on its gate. Since the PMOS no longer acts as a low-impedance switch, a dropout voltage across the PMOS is introduced to increase the conduction loss which needs to be taken into account for thermal consideration.

In the pass-through operation, the device stops switching. The rectifying PMOS constantly turns on and low-side switch constantly turns off. The output voltage is the input voltage minus the voltage drop across the DC resistance (DCR) of the inductor and the on-resistance of the rectifying PMOS.

## Thermal Shutdown

The AW3606A/AW3606B has an integrated thermal protection. The protection circuit senses the internal temperature of the chip and stop switching when temperature reaches 150°C. After the temperature returns to a safe value 25°C below the shutdown temperature, the system starts operating again.

## Application Information

### Programming the Output Voltage

There is the way to set the output voltage of the AW3606A.

The output voltage could be adjusted by connecting FB to the tap of an external voltage divider from VOUT to ground, as shown in Equation1, and the typical voltage at the FB pin is VREF of 1.03V.

$$V_{OUT} = V_{REF} \cdot \frac{R_1 + R_2}{R_2}$$

For the best accuracy and low quiescent current, R1 and R2 value usually are large. The current following through R2 should be 100 times larger than FB pin leakage current. Reducing the R2 value can improve the robustness against noise injection. Increasing the R2 value reduces the FB divider current for achieving the highest efficiency at low load current. For example, 1MΩ and 249kΩ resistors with 1% maximum tolerance are selected for R1 and R2.

For AW3606B, the FB pin is suggested to be connected to GND.

### Maximum Output Current

The maximum output current of the AW3606A/AW3606B can be estimated by Equation2. It determined by the input to output ratio and the current limit of the step-up converter.

$$I_{OUT(MAX)} = \frac{V_{IN} \cdot (I_{LIM} - \frac{\Delta I_L}{2}) \cdot \eta}{V_{OUT}}$$

Where  $\eta$  is the conversion efficiency, using 85% for estimation;  $\Delta I_L$  is the current ripple value and  $I_{LIM}$  is the switch current limit.

Typically, the maximum output current of the typical application circuit with 5V adjustable output voltage is as follows in this table.

VIN	2.5V	3.3V	3.7V	4.4V
Maximum output current	0.4A	0.6A	0.7A	0.9A

Voltage across the DCR decreases the effective voltage across the inductor, which will affect the maximum output current. Especially at low input voltage, the voltage across the DCR and the low-side switch become large enough that could not be ignored for the effect on maximum output current.

## Inductor Selection

Inductor is the most important component in power regulator design. In order to ensure proper operation of the steady state, transient behavior, and loop stability, inductor value, saturation current, and dc resistance (DCR) deserve careful consideration.

The device is optimized to with inductor values between 1 $\mu$ H and 2.2 $\mu$ H. For best stability consideration, a 2.2 $\mu$ H inductor is recommended for  $V_{OUT} > 3.0V$  condition while choosing a 1 $\mu$ H inductor for applications under  $V_{OUT} \leq 3.0V$  condition. Inductors recommended for AW3606A/AW3606B device are as follows in this table.

VOUT (V)	Inductance ( $\mu$ H)	Saturation Current (A)	DC Resistance (m $\Omega$ )	Size (LxWxH)	Part number	Manufacturer
>3.0	2.2	2.4	116	2.0x1.6x1.2	DFE201612E-2R2M	muRata
	2.2	2.1	100	2.0x1.6x1.0	WPN201610U2R2MT	Sunlord
	2.2	1.95	80	2.5x2.0x1.2	74404024022	Würth
<3.0	1	2	80	2.0x1.6x0.9	LQM2MPN1R0MGH	muRata
	1	3.5	50	2.0x1.6x1.0	WPN201610U1R0MT	Sunlord
	1	2.6	37	2.5x2.0x1.2	74404024010	Würth

For the selected inductor, the operating frequency of the device in continuous current mode can be estimated by the following equation.

$$f = \frac{V_{IN} \cdot (V_{OUT} - V_{IN} \cdot \eta)}{L \cdot V_{OUT} \cdot \Delta I_L}$$

Where  $\Delta I_L$  is the inductor ripple current,  $\eta$  is the conversion efficiency.

## Capacitor Selection

For best output and input voltage filtering, low ESR X5R or X7R ceramic capacitors are recommended.

Low ESR input capacitors reduce input noise and voltage ripple. An input capacitor value of 10 $\mu$ F is normally recommended to improve transient behavior of the regulator and EMI behavior of the total power supply circuit. The input capacitor should be placed close to the VIN and GND pins of the device.

For the output capacitor of VOUT pin, small ceramic capacitor and a large one are recommended. The small capacitor value of 1 $\mu$ F should be placed as close as possible to the VOUT and GND pins of the device.

It's necessary to consider the ceramic capacitor's derating effect under bias carefully. Capacitors recommended for AW3606A/AW3606B device are as follows in this table.

Part Number	Capacitance (μF)	Rated Voltage (V)	Size Code (inch)	Temperature Characteristics	Manufacturer
GRM155R60J106ME05	10	6.3	0402	X5R	muRata
GRM155R61A106ME11	10	10	0402	X5R	muRata
GRM188R60J106ME47	10	6.3	0603	X5R	muRata
GRM188R61A106MAAL	10	10	0603	X5R	muRata
C1608X5R0J106K080AB	10	6.3	0603	X5R	TDK
C1608X5R1A106K080AC	10	10	0603	X5R	TDK
CC0402MRX5R5BB106	10	6.3	0402	X5R	YAGEO
CC0603KRX5R5BB106	10	6.3	0603	X5R	YAGEO

## PCB Layout Consideration

AW3606A/AW3606B is a boost convert, to obtain the optimal performance, PCB layout should be considered carefully. Here are some guidelines:

1. C1, C2, C3, and L1 should be placed as close to chip as possible;
2. Wide and short traces should be used for main current path and the power ground paths;
3. Considering the problem of high current temperature rise, it is necessary to enlarge the area of copper floor around the chip to dissipate heat;
4. For AW3606A, a  $C_{OP}$  is recommended between FB and OUT pin to optimize the load transient response performance.
5. For AW3606B, the FB pin should be connected to the GND.

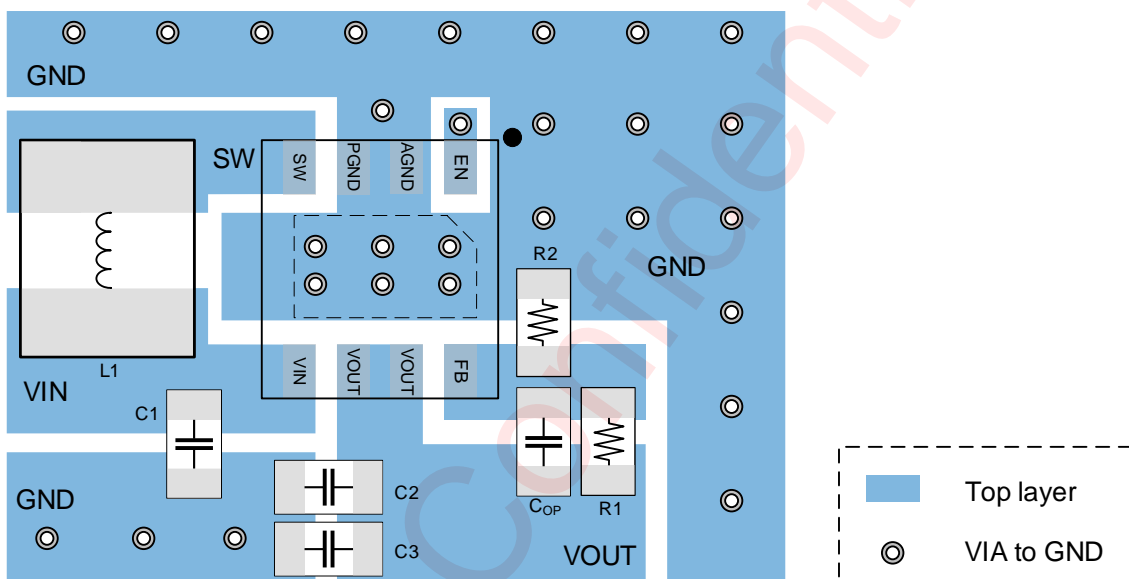

**AW3606A Layout Recommendation**

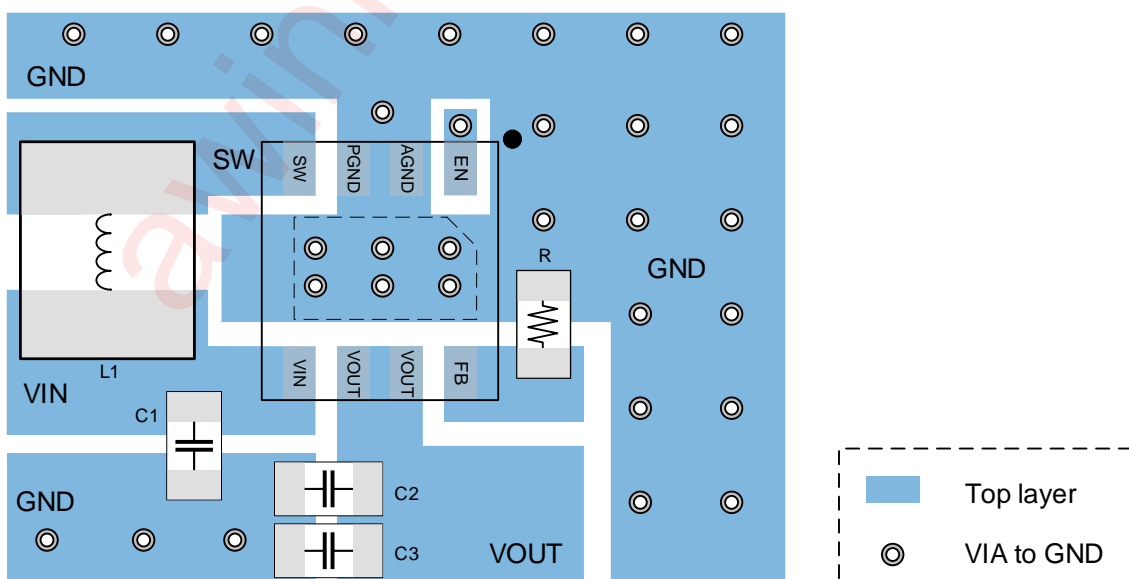

**AW3606B Layout Recommendation**

## Tape And Reel Information

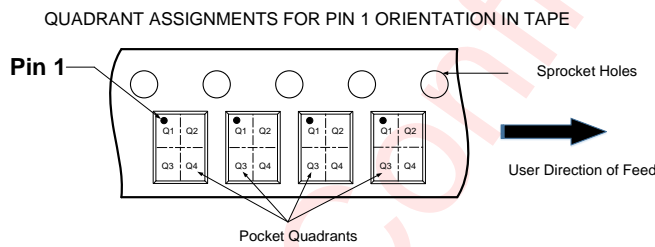
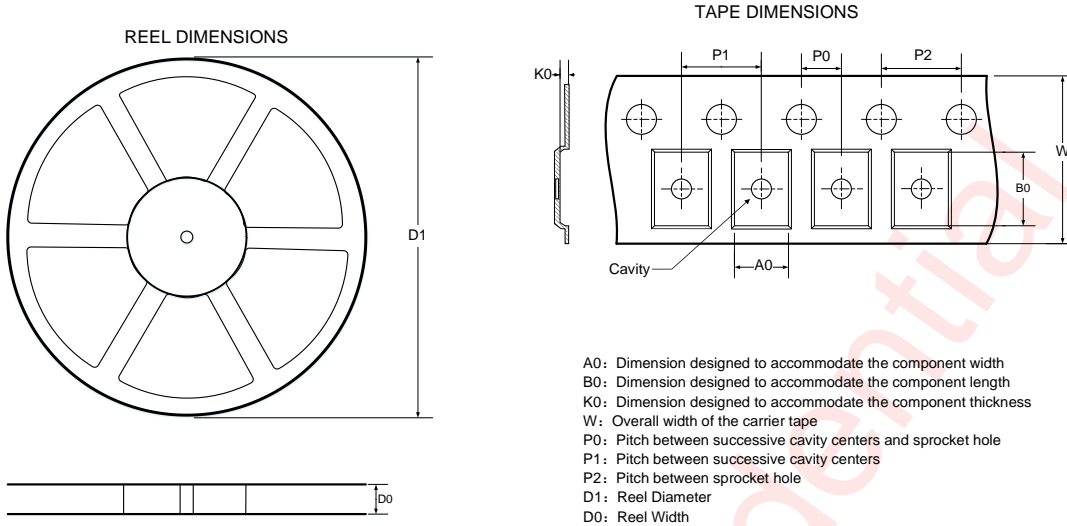

**DIMENSIONS AND PIN1 ORIENTATION**

D1 (mm)	D0 (mm)	A0 (mm)	B0 (mm)	K0 (mm)	P0 (mm)	P1 (mm)	P2 (mm)	W (mm)	Pin1 Quadrant
178	8.4	2.25	2.25	0.75	2	4	4	8	Q1

All dimensions are nominal

Package Description

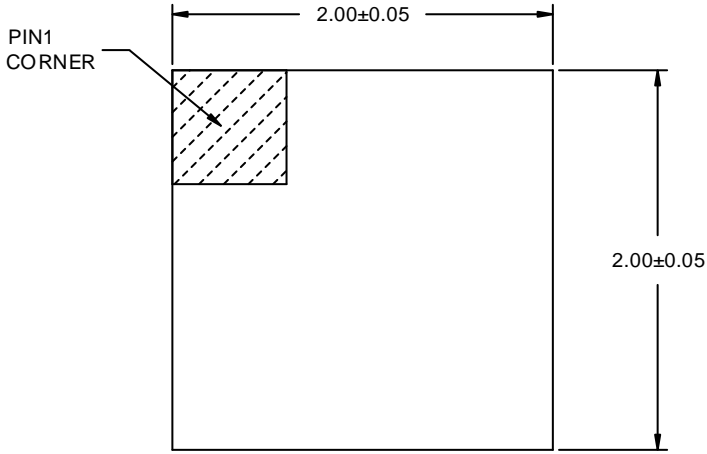

TOP VIEW

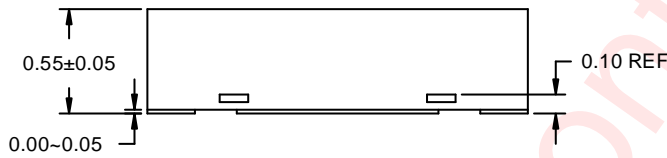

SIDE VIEW

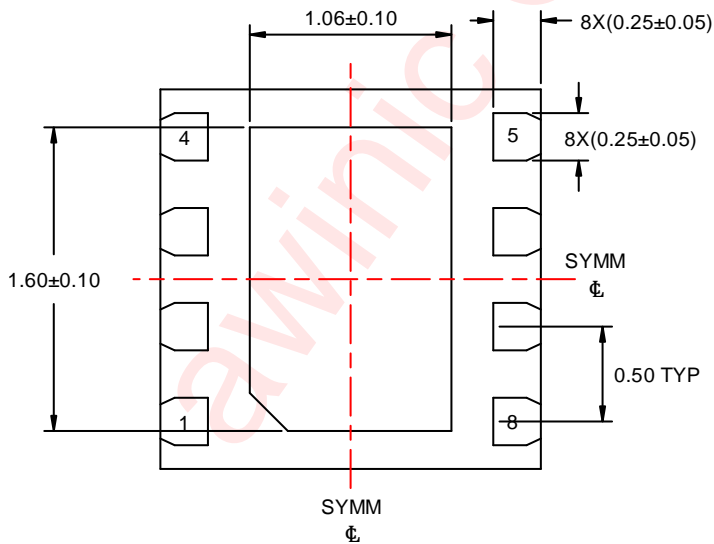

BOTTOM VIEW

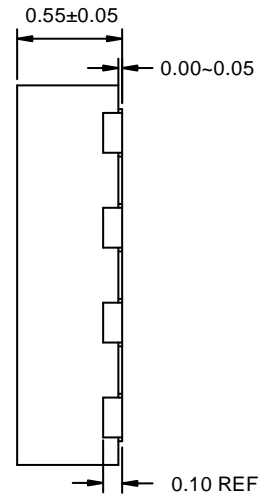

SIDE VIEW

Unit: mm

Land Pattern Data

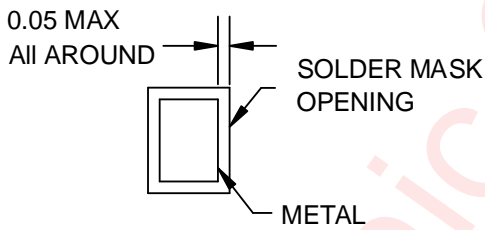
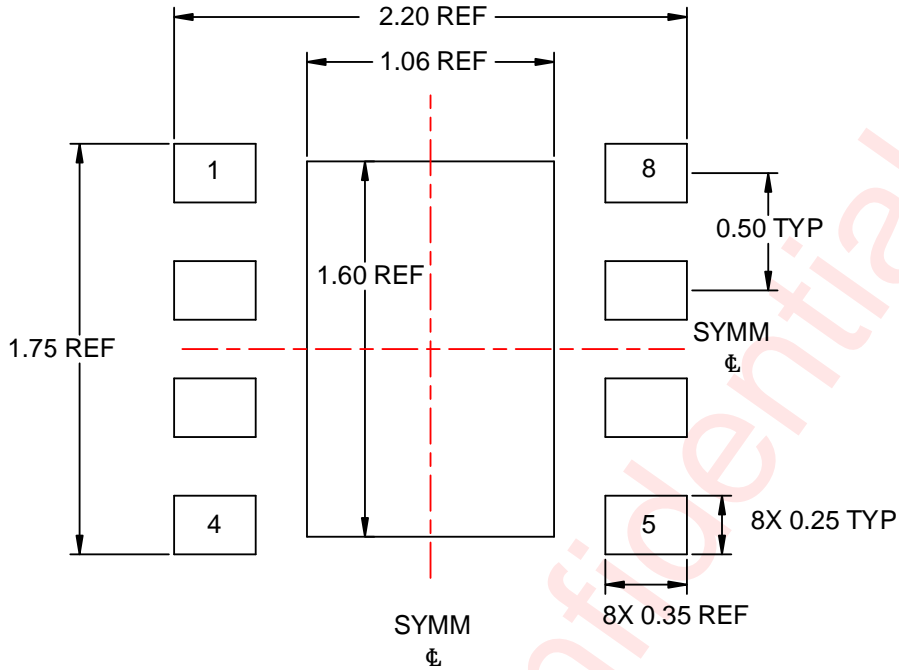

NON-SOLDER MASK DEFINED

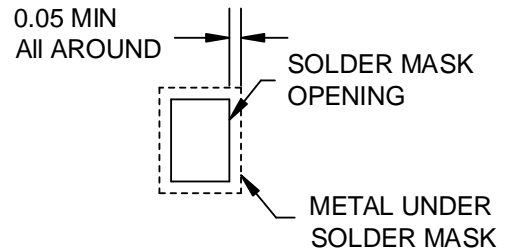

SOLDER MASK DEFINED

Unit: mm

## Revision History

Version	Date	Change Record
V1.0	Nov 2021	Officially released
V1.1	Dec 2021	Update Output Voltage
V1.2	Dec 2021	Add AW3606B

awinic Confidential

## Disclaimer

All trademarks are the property of their respective owners. Information in this document is believed to be accurate and reliable. However, Shanghai AWINIC Technology Co., Ltd (AWINIC Technology) does not give any representations or warranties, expressed or implied, as to the accuracy or completeness of such information and shall have no liability for the consequences of use of such information.

AWINIC Technology reserves the right to make changes to information published in this document, including without limitation specifications and product descriptions, at any time and without notice. Customers shall obtain the latest relevant information before placing orders and shall verify that such information is current and complete. This document supersedes and replaces all information supplied prior to the publication hereof.

AWINIC Technology products are not designed, authorized or warranted to be suitable for use in medical, military, aircraft, space or life support equipment, nor in applications where failure or malfunction of an AWINIC Technology product can reasonably be expected to result in personal injury, death or severe property or environmental damage. AWINIC Technology accepts no liability for inclusion and/or use of AWINIC Technology products in such equipment or applications and therefore such inclusion and/or use is at the customer's own risk.

Applications that are described herein for any of these products are for illustrative purposes only. AWINIC Technology makes no representation or warranty that such applications will be suitable for the specified use without further testing or modification.

All products are sold subject to the general terms and conditions of commercial sale supplied at the time of order acknowledgement.

Nothing in this document may be interpreted or construed as an offer to sell products that is open for acceptance or the grant, conveyance or implication of any license under any copyrights, patents or other industrial or intellectual property rights.

Reproduction of AWINIC information in AWINIC data books or data sheets is permissible only if reproduction is without alteration and is accompanied by all associated warranties, conditions, limitations, and notices. AWINIC is not responsible or liable for such altered documentation. Information of third parties may be subject to additional restrictions.

Resale of AWINIC components or services with statements different from or beyond the parameters stated by AWINIC for that component or service voids all express and any implied warranties for the associated AWINIC component or service and is an unfair and deceptive business practice. AWINIC is not responsible or liable for any such statements.