



180-091 (05) In-Line Receptacle Advanced Fiber Optic Connector MIL-DTL-38999 Series III Type

D38999
Series III

B

MIL-DTL-38999 type advanced fiber optic receptacle connector

How To Order

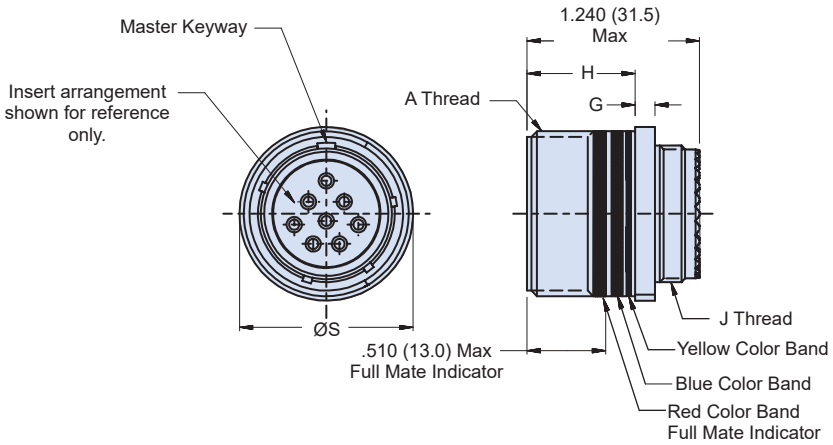
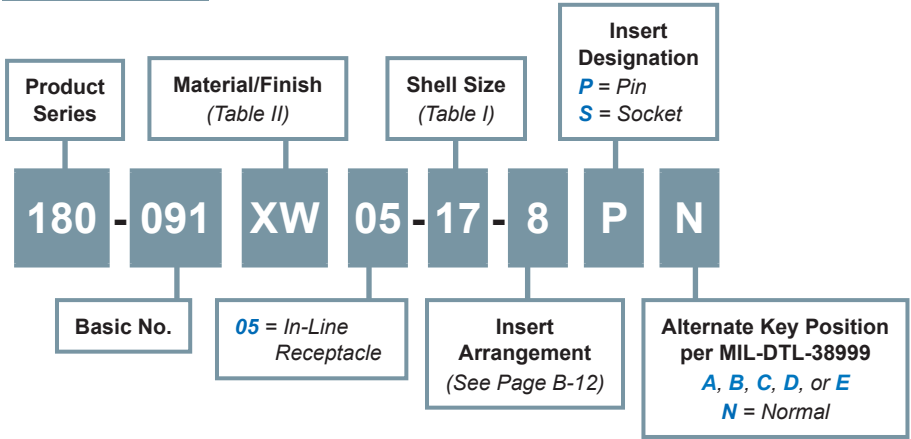

05 - IN-LINE RECEPTACLE

Material and Finish

- Shell: See Table II
- Insulator: High Grade Rigid Dielectric
- Seals: Fluorosilicone
- Retention Clip: Copper Alloy

Notes

Insert arrangement in accordance with MIL-STD-1560, See Page B-12.
 Blue Color Band indicates rear release retention system.
 For appropriate Glenair Terminus part numbers, see Glenair Drawing 181-001 and 181-002.

**180-091 (05) In-Line Receptacle
Advanced Fiber Optic Connector
MIL-DTL-38999 Series III Type**



MIL-DTL-38999
Series III Type

B

Table I						
Shell Size Code	Shell Size	A Thread	G	H	Ø S	J Thread
B	11	.7500-1P-.3L-TS-2A	.144 (3.7) .083 (2.1)	.823 (20.9) .768 (19.5)	.840 (21.3)	M15 x 1.0-6g 0.100R
C	13	.8750-1P-.3L-TS-2A	.144 (3.7) .083 (2.1)	.823 (20.9) .768 (19.5)	.963 (24.5)	M18 x 1.0-6g 0.100R
D	15	1.0000-1P-.3L-TS-2A	.144 (3.7) .083 (2.1)	.823 (20.9) .768 (19.5)	1.090 (27.7)	M22 x 1.0-6g 0.100R
E	17	1.1875-1P-.3L-TS-2A	.144 (3.7) .083 (2.1)	.823 (20.9) .768 (19.5)	1.275 (32.4)	M25 x 1.0-6g 0.100R
F	19	1.2500-1P-.3L-TS-2A	.144 (3.7) .083 (2.1)	.823 (20.9) .768 (19.5)	1.337 (34.0)	M28 x 1.0-6g 0.100R
G	21	1.3750-1P-.3L-TS-2A	.171 (65.2) .083 (39.8)	.791 (20.0) .736 (18.7)	1.463 (37.2)	M31 x 1.0-6g 0.100R
H	23	1.5000-1P-.3L-TS-2A	.171 (65.2) .083 (39.8)	.791 (20.0) .736 (18.7)	1.587 (40.3)	M34 x 1.0-6g 0.100R
J	25	1.6250-1P-.3L-TS-2A	.171 (65.2) .083 (39.8)	.791 (20.0) .736 (18.7)	1.713 (43.5)	M37 x 1.0-6g 0.100R

Material and Finish		
Code	Material	Finish Description
M	Aluminum Alloy	Electroless Nickel
MT		Nickel - PTFE, Grey
NF		Cadmium, Olive Drab
ZN		Zinc-Nickel, Olive Drab
ZNU		Zinc-Nickel, Black
ZR		Zinc-Nickel, Black (RoHS)
XM	Composite	Electroless Nickel
XMT		Nickel - PTFE, Grey
XW		Cadmium, Olive Drab
XZN		Zinc-Nickel, Black
MS	Stainless Steel	Electroless Nickel
ZL		Electro-Deposited Nickel
Z1		Passivate
AB	Marine Bronze	None (Clean Only)

Refer to Appendix for material/finish details

Mouser Electronics

Authorized Distributor

Click to View Pricing, Inventory, Delivery & Lifecycle Information:

[Glenair:](#)

[180-091Z105-13-4PN](#) [180-091NF05-11-2SN](#) [180-091Z105-17-8PN](#) [180-091XM05-13-4PN](#) [180-091XM05-25-37PN](#)