

### features

- Flameproof coating is available (specify "CFP")
- Suitable for automatic machine insertion
- Marking: Beige body color with color-coded bands on CF  
Green body color with color-coded bands on CFP  
Ivory body color with color-coded bands on CFS1/4

### dimensions and construction

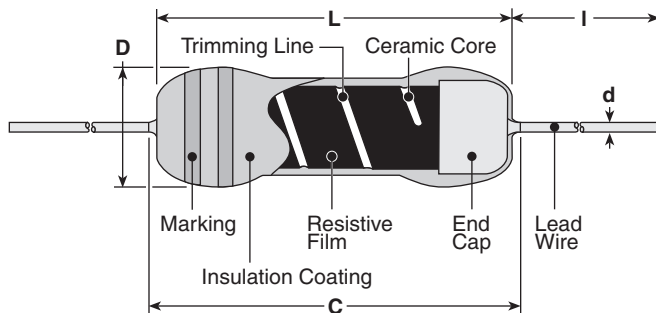

Type	Dimensions inches (mm)				
	L	C (max.)	D	d (nom.)	I
CFS1/4 CFPS1/4	.126±.008 (3.2±0.2)	.165 (4.2)	.067±.02 (1.7±0.2)	.018 (0.45)	1.18±.12 (30.0±3.0)
CF1/4 CFP1/4	.256 (6.5)	.280 (7.1)	.089±.01 (2.25±0.25)	.024 (0.6)	
CF1/2 CFP1/2	.335 (8.5)	.365 (9.27)	.118±.02 (3.0±0.5)	.028 (0.7)	
CFS1/2 CFPS1/2	.248±.02 (6.3±0.5)	.280 (7.1)	.098±.02 (2.5±0.5)	.024 (0.6)	

### ordering information

New Part #	CF	1/4	C	T52	R	103	J
Type	CF CFP	Power Rating S1/4: 0.25W 1/4: 0.25W 1/2: 0.5W S1/2: 0.5W	Termination Material C: SnCu L: SnPb	Taping and Forming Axial: T26, T52 Radial: VT, MT, MHT, VTP, VTE U Forming: U, UCL, US M Forming: M5, M10, M12.5	Packaging A: Ammo R: Reel	Nominal Resistance 2 significant figures + 1 multiplier "R" indicates decimal on value <10Ω	Tolerance G: ±2% J: ±5%

For further information on packaging, please refer to Appendix C.

## applications and ratings

Part Designation	Power Rating @ 70°C	Minimum Dielectric Withstanding Voltage	T.C.R. (ppm/°C)				Resistance Range E-24 (G±2%)	Resistance Range E-24 (J±5%)	Absolute Maximum Working Voltage	Absolute Maximum Overload Voltage
			+350 to -450	0 to -700	0 to -1000	0 to -1300				
CFS1/4	0.25W	300V	2.2Ω - 47kΩ	51kΩ - 100kΩ	110kΩ - 330kΩ	360kΩ - 1MΩ	10Ω - 330kΩ	2.2Ω - 1MΩ	250V	500V
CFPS1/4							10Ω - 100kΩ	1.1Ω - 1MΩ		
CF1/4							10Ω - 1MΩ	1.0Ω - 22MΩ		
CFP1/4	1.0Ω - 22MΩ									
CF1/2	0.50W	700V	2.2Ω - 100kΩ	110kΩ - 1MΩ	1.1MΩ - 2.2MΩ	2.4MΩ - 5.1MΩ	10Ω - 1MΩ	2.2Ω - 5.1MΩ	400V	800V
CFP1/2								2.2Ω - 1MΩ		
CFS1/2								2.2Ω - 5.1MΩ	350V	700V
CFPS1/2										

## environmental applications

### Derating Curve

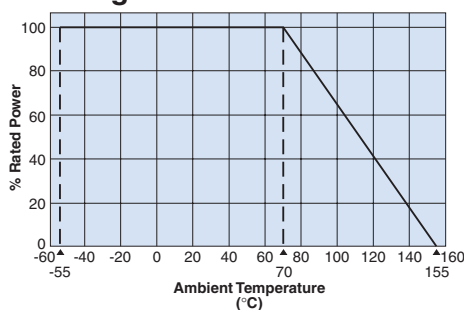

### Surface Temperature Rise

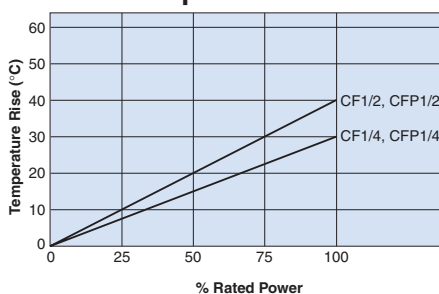

### Load Life @ 70°C, 1000 Hr

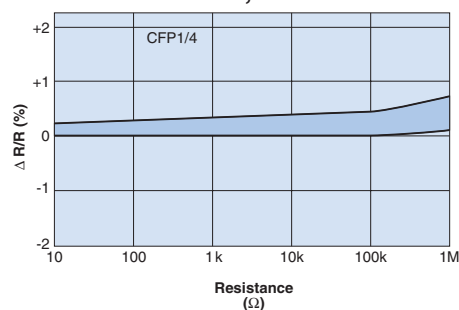

## Performance Characteristics

Parameter	Requirement		Test Method
	CF1/4, CFP1/4	CF1/2, CFP1/2	
Temperature Coefficient (ppm/°C) Maximum			
+350 to -450	≤10K	≤22KΩ	—
-600	11K - 250KΩ	24K - 470KΩ	—
-1000	160K - 2.2MΩ	510K - 2.2MΩ	—
-1500	2.4M - 6.8MΩ	2.4M - 10MΩ	—
-2500	7.5M - 15MΩ	11M - 16MΩ	—
-3200	16M - 22MΩ	16M - 22MΩ	—
Short Time Overload	±1.0%		2.5 x RCWV* for 5 seconds
Resistance to Solder Heat			MIL-STD-202, Method 210
Moisture Resistance	±5.0%		MIL-STD-202, Method 106
Load Life	±3.0%		MIL-STD-202, Method 108, 70°C, 1000 hours
Temperature Cycling	±1.0%		-55°C, 25°C, 125°C, 25°C for 5 cycles
Vibration			MIL-STD-202, Method 214
Terminal Strength	5 # Minimum		MIL-STD-202, Method 211
Current Noise	0.02 - 0.6 μv/v	0.02 - 1.00 μv/v	MIL-STD-202, Method 308
Voltage Coefficient	<5 ppm/v		MIL-STD-202, Method 301

\* RCWV = Rated Continuous Working Voltage