

Siemens  
EcoTech



Circuit breaker size S00 for motor protection, CLASS 10 A-release 0.45...0.63 A N-release 8.2 A screw terminal Standard switching capacity



product brand name	SIRIUS
product designation	Circuit breaker
design of the product	For motor protection
product type designation	3RV2
<b>General technical data</b>	
size of the circuit-breaker	S00
size of contactor can be combined company-specific	S00, S0
product extension auxiliary switch	Yes
power loss [W] for rated value of the current	
• at AC in hot operating state	5.5 W
• at AC in hot operating state per pole	1.8 W
insulation voltage with degree of pollution 3 at AC rated value	690 V
surge voltage resistance rated value	6 kV
shock resistance according to IEC 60068-2-27	25g / 11 ms
mechanical service life (operating cycles)	
• of the main contacts typical	100 000
• of auxiliary contacts typical	100 000
electrical endurance (operating cycles) typical	100 000
reference code according to IEC 81346-2	Q
Substance Prohibitance (Date)	10/01/2009
SVHC substance name	Lead - 7439-92-1
<b>Ambient conditions</b>	
installation altitude at height above sea level maximum	2 000 m
ambient temperature	
• during operation	-20 ... +60 °C
• during storage	-50 ... +80 °C
• during transport	-50 ... +80 °C
relative humidity during operation	10 ... 95 %
<b>Main circuit</b>	
number of poles for main current circuit	3
adjustable current response value current of the current-dependent overload release	0.45 ... 0.63 A
operating voltage	
• rated value	20 ... 690 V
• at AC-3 rated value maximum	690 V
• at AC-3e rated value maximum	690 V
operating frequency rated value	50 ... 60 Hz

<b>operational current rated value</b>	0.63 A
<b>operational current</b>	
• at AC-3 at 400 V rated value	0.63 A
• at AC-3e at 400 V rated value	0.63 A
<b>operating power</b>	
• at AC-3	
— at 230 V rated value	0.1 kW
— at 400 V rated value	0.18 kW
— at 500 V rated value	0.2 kW
— at 690 V rated value	0.3 kW
• at AC-3e	
— at 230 V rated value	0.1 kW
— at 400 V rated value	0.18 kW
— at 500 V rated value	0.2 kW
— at 690 V rated value	0.3 kW
<b>operating frequency</b>	
• at AC-3 maximum	15 1/h
• at AC-3e maximum	15 1/h
<b>Auxiliary circuit</b>	
<b>number of NC contacts for auxiliary contacts</b>	0
<b>number of NO contacts for auxiliary contacts</b>	0
number of CO contacts for auxiliary contacts	0
<b>Protective and monitoring functions</b>	
<b>product function</b>	
• ground fault detection	No
• phase failure detection	Yes
<b>trip class</b>	CLASS 10
<b>design of the overload release</b>	thermal
<b>maximum short-circuit current breaking capacity (I<sub>cu</sub>)</b>	
• at AC at 240 V rated value	100 kA
• at AC at 400 V rated value	100 kA
• at AC at 500 V rated value	100 kA
• at AC at 690 V rated value	100 kA
<b>operating short-circuit current breaking capacity (I<sub>cs</sub>) at AC</b>	
• at 240 V rated value	100 kA
• at 400 V rated value	100 kA
• at 500 V rated value	100 kA
• at 690 V rated value	100 kA
response value current of instantaneous short-circuit trip unit	8.2 A
<b>UL/CSA ratings</b>	
<b>full-load current (FLA) for 3-phase AC motor</b>	
• at 480 V rated value	0.63 A
• at 600 V rated value	0.63 A
<b>Short-circuit protection</b>	
<b>product function short circuit protection</b>	Yes
<b>design of the short-circuit trip</b>	magnetic
<b>design of the fuse link for IT network for short-circuit protection of the main circuit</b>	
• at 690 V	gL/gG 6 A
<b>Installation/ mounting/ dimensions</b>	
<b>mounting position</b>	any
<b>fastening method</b>	screw and snap-on mounting onto 35 mm DIN rail according to DIN EN 60715
<b>height</b>	97 mm
<b>width</b>	45 mm
<b>depth</b>	97 mm
<b>required spacing</b>	
• with side-by-side mounting at the side	0 mm
• for grounded parts at 400 V	
— downwards	30 mm
— upwards	30 mm
— at the side	9 mm

<ul style="list-style-type: none"> <li>• for live parts at 400 V <ul style="list-style-type: none"> <li>— downwards</li> <li>— upwards</li> <li>— at the side</li> </ul> </li> <li>• for grounded parts at 500 V <ul style="list-style-type: none"> <li>— downwards</li> <li>— upwards</li> <li>— at the side</li> </ul> </li> <li>• for live parts at 500 V <ul style="list-style-type: none"> <li>— downwards</li> <li>— upwards</li> <li>— at the side</li> </ul> </li> <li>• for grounded parts at 690 V <ul style="list-style-type: none"> <li>— downwards</li> <li>— upwards</li> <li>— backwards</li> <li>— at the side</li> <li>— forwards</li> </ul> </li> <li>• for live parts at 690 V <ul style="list-style-type: none"> <li>— downwards</li> <li>— upwards</li> <li>— backwards</li> <li>— at the side</li> <li>— forwards</li> </ul> </li> </ul>	30 mm 30 mm 9 mm 30 mm 30 mm 9 mm 30 mm 30 mm 9 mm 50 mm 50 mm 0 mm 30 mm 0 mm 50 mm 50 mm 0 mm 30 mm 0 mm
--	--

#### Connections/ Terminals

<b>type of electrical connection</b>	
<ul style="list-style-type: none"> <li>• for main current circuit</li> </ul>	screw-type terminals
<b>arrangement of electrical connectors for main current circuit</b>	Top and bottom
<b>type of connectable conductor cross-sections</b>	
<ul style="list-style-type: none"> <li>• for main contacts <ul style="list-style-type: none"> <li>— solid or stranded</li> <li>— finely stranded with core end processing</li> </ul> </li> <li>• for AWG cables for main contacts</li> </ul>	2x (0,75 ... 2,5 mm <sup>2</sup> ), 2x 4 mm <sup>2</sup> 2x (0.5 ... 1.5 mm <sup>2</sup> ), 2x (0.75 ... 2.5 mm <sup>2</sup> ) 2x (18 ... 14), 2x 12
<b>tightening torque</b>	
<ul style="list-style-type: none"> <li>• for main contacts with screw-type terminals</li> </ul>	0.8 ... 1.2 N·m
<b>design of screwdriver shaft</b>	Diameter 5 to 6 mm
<b>size of the screwdriver tip</b>	Pozidriv size 2
<b>design of the thread of the connection screw</b>	
<ul style="list-style-type: none"> <li>• for main contacts</li> </ul>	M3

#### Safety related data

product function suitable for safety function	Yes
<b>suitability for use</b>	
<ul style="list-style-type: none"> <li>• safety-related switching on</li> <li>• safety-related switching OFF</li> </ul>	No Yes
<b>service life maximum</b>	10 a
<b>test wear-related service life necessary</b>	Yes
<b>proportion of dangerous failures</b>	
<ul style="list-style-type: none"> <li>• with low demand rate according to SN 31920</li> <li>• with high demand rate according to SN 31920</li> </ul>	40 % 50 %
<b>B10 value with high demand rate according to SN 31920</b>	5 000
<b>failure rate [FIT] with low demand rate according to SN 31920</b>	50 FIT
<b>ISO 13849</b>	
<b>device type according to ISO 13849-1</b>	3
<b>overdimensioning according to ISO 13849-2 necessary</b>	Yes
<b>IEC 61508</b>	
<b>safety device type according to IEC 61508-2</b>	Type A
<b>T1 value</b>	
<ul style="list-style-type: none"> <li>• for proof test interval or service life according to IEC 61508</li> </ul>	10 a

Electrical Safety	
protection class IP on the front according to IEC 60529	IP20
touch protection on the front according to IEC 60529	finger-safe, for vertical contact from the front
Display	
display version for switching status	Handle
Approvals Certificates	
General Product Approval	



[Confirmation](#)



[KC](#)

General Product Approval	For use in hazardous locations	Test Certificates		Marine / Shipping
			<a href="#">Type Test Certificates/Test Report</a>	<a href="#">Special Test Certificate</a>

Marine / Shipping	other			
				<a href="#">Miscellaneous</a>

other	Railway	Environment	
<a href="#">Confirmation</a>		<a href="#">Special Test Certificate</a>	<a href="#">Confirmation</a>

Environment
<a href="#">Environmental Confirmations</a>

**Further information**

- Information on the packaging  
<https://support.industry.siemens.com/cs/ww/en/view/109813875>
- Information- and Downloadcenter (Catalogs, Brochures,...)  
<https://www.siemens.com/ic10>
- Industry Mall (Online ordering system)  
<https://mall.industry.siemens.com/mall/en/en/Catalog/product?mlfb=3RV2011-0GA10>
- Cax online generator  
<http://support.automation.siemens.com/WWW/CAXorder/default.aspx?lang=en&mlfb=3RV2011-0GA10>
- Service&Support (Manuals, Certificates, Characteristics, FAQs,...)  
<https://support.industry.siemens.com/cs/ww/en/ps/3RV2011-0GA10>
- Image database (product images, 2D dimension drawings, 3D models, device circuit diagrams, EPLAN macros, ...)  
[http://www.automation.siemens.com/bilddb/cax\\_de.aspx?mlfb=3RV2011-0GA10&lang=en](http://www.automation.siemens.com/bilddb/cax_de.aspx?mlfb=3RV2011-0GA10&lang=en)
- Characteristic: Tripping characteristics, I<sub>t</sub>, Let-through current  
<https://support.industry.siemens.com/cs/ww/en/ps/3RV2011-0GA10/char>
- Further characteristics (e.g. electrical endurance, switching frequency)  
<http://www.automation.siemens.com/bilddb/index.aspx?view=Search&mlfb=3RV2011-0GA10&objecttype=14&gridview=view1>

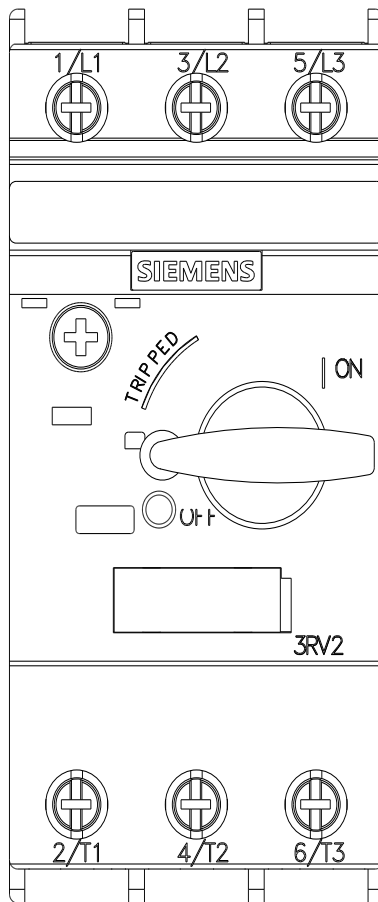



last modified:

4/12/2024 