

## 3-Channel LED Drivers With Auto Charging Indicator

### Features

- 3-channel constant current LED drivers
  - 4-level global maximum current: 5mA, 10mA, 15mA, 30mA
  - 16-level individual current for each LED, 4096 mixed-color available
  - 256-level individual PWM dimming
- Automatic breathing light
  - Three independent pattern controllers
  - Individual and sync control selectable
- Support charging indication under low battery voltage condition
  - Directly start up breathing light on LED1 via pulling pin CHRG up to high
  - AW2016: LED1 breathing with 4.5s period, max output current 6mA
  - AW2016A: LED1 always on, output current 3mA
- LED current accuracy:  $\pm 3\%$
- LED matching accuracy:  $\pm 3\%$
- Low dropout voltage: 50mV
- Shutdown control by pulling down pin SCL
- 400kHz I<sup>2</sup>C interface (address: 0x64), interface voltage 1.8V~3.3V
- Single power supply, 2.5V~5.5V
- QFN 1.2mm×1.2mm×0.37mm-8L package

### Applications

Mobile phones, TWS  
E-sports devices  
Smart home appliance

### Typical Application Circuit

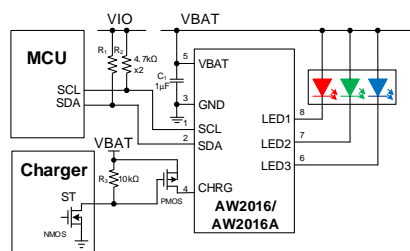

Charging Status Indication Application

### General Description

AW2016/AW2016A is a three channels constant current LED driver with auto charging indication function. The max output current is 4-level selectable (5mA/10mA/15mA/30mA). The driving current of each LED is 16 levels configurable so as to achieve 4096 color mixing. The 256-level exponential PWM creates fine and smooth dimming effect even in low brightness.

AW2016 can provide auto charging indication under the condition of low battery voltage. When the voltage of battery is too low, and the I<sup>2</sup>C interface halts, the internal pattern controller will be activated by pin CHRG being pulled high, and pin LED1 of AW2016 will output breathing lighting with period of 4.5s and max 6mA current. LED1 of AW2016A will be always on with 3mA constant current.

AW2016/AW2016A contain three independent pattern controllers. Three LEDs can be controlled to work synchronously or individually according to different applications.

A 400kHz I<sup>2</sup>C interface is provided with 1.8V~3.3V interface voltage. The QFN 1.2mm×1.2mm×0.37mm-8L package occupies very small PCB area.

## Pin Configuration And Top Mark

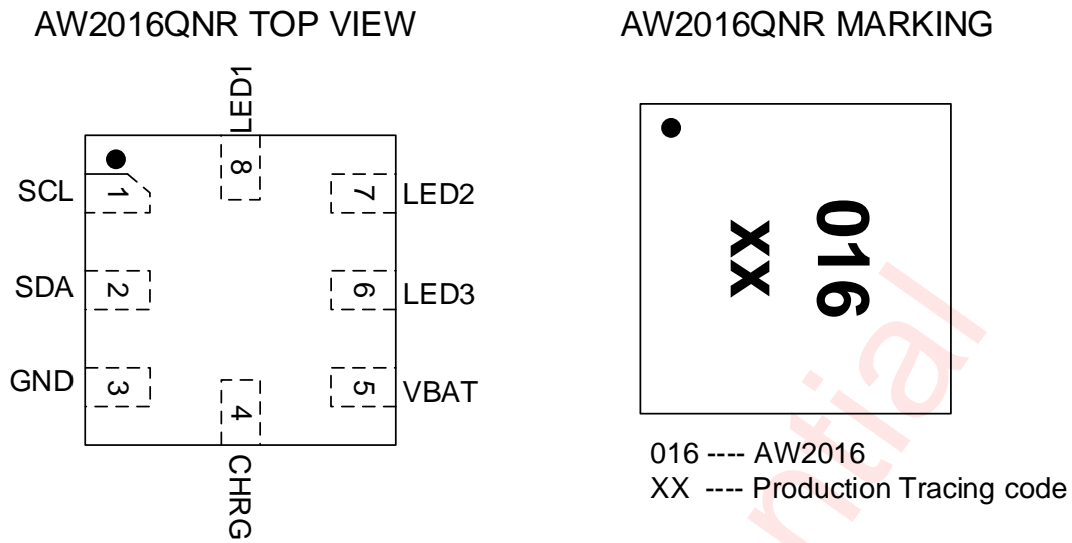

Figure 1 AW2016QNR Pin Configuration and Top Marking

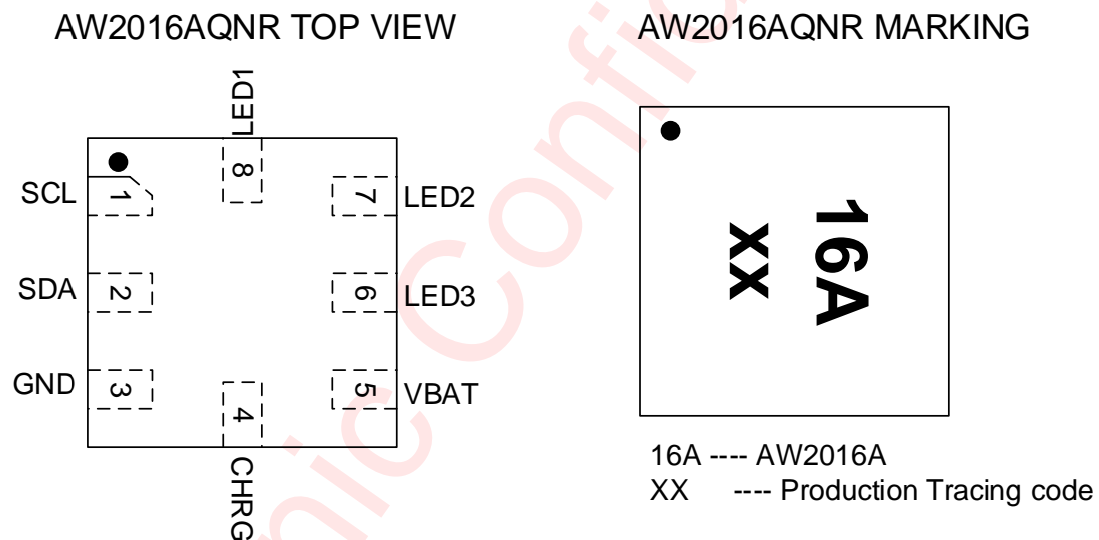

Figure 2 AW2016AQNR Pin Configuration and Top Marking

## Pin Definition

No.	Name	Description
1	SCL	Serial clock input for I <sup>2</sup> C interface
2	SDA	Serial data I/O for I <sup>2</sup> C interface
3	GND	Ground
4	CHRG	Charge indicator input, active high
5	VBAT	Power supply (2.5V~5.5V)
6	LED3	LED3 cathode driver, anode connected to VBAT
7	LED2	LED2 cathode driver, anode connected to VBAT
8	LED1	LED1 cathode driver, anode connected to VBAT

### Functional Block Diagram

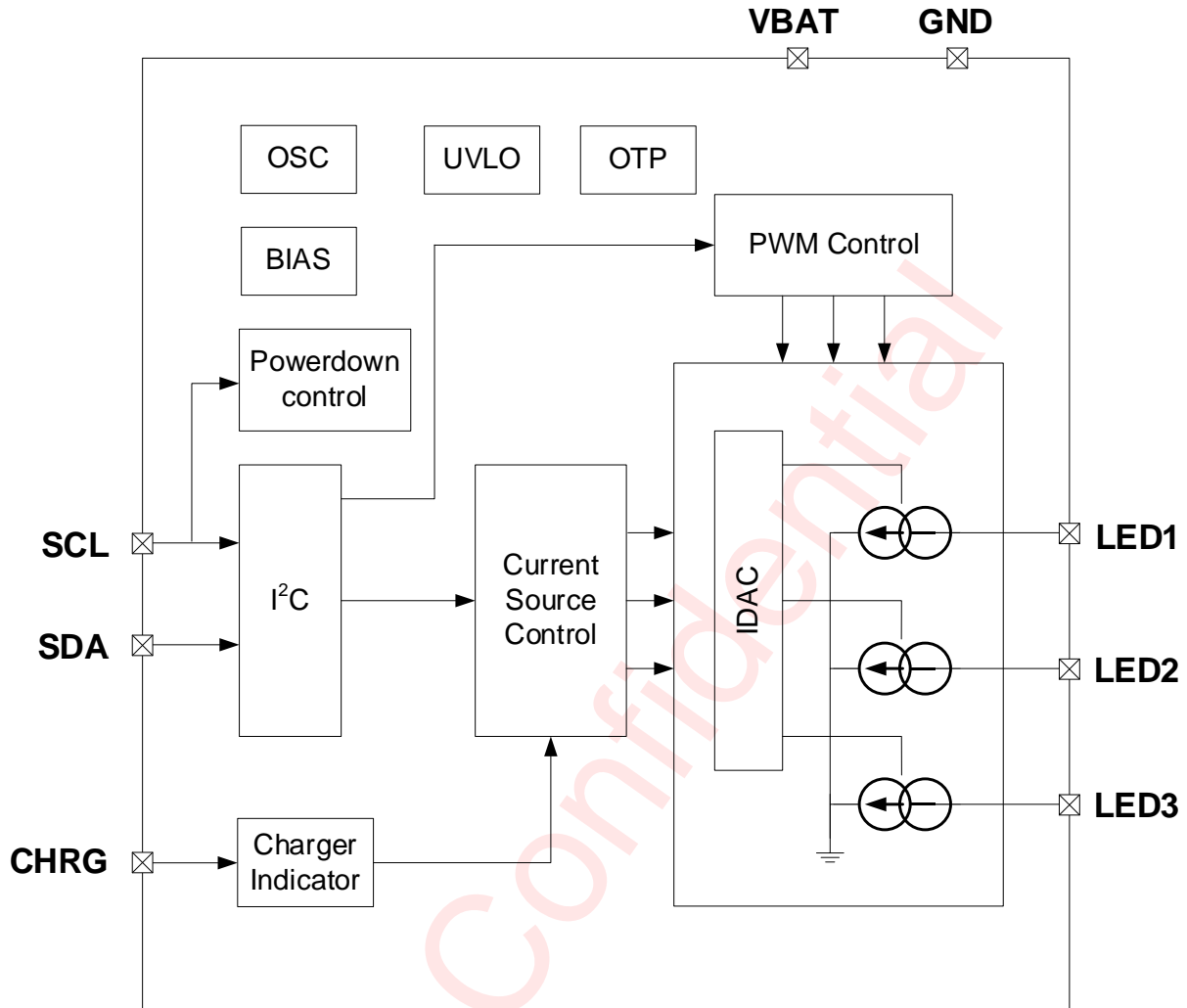
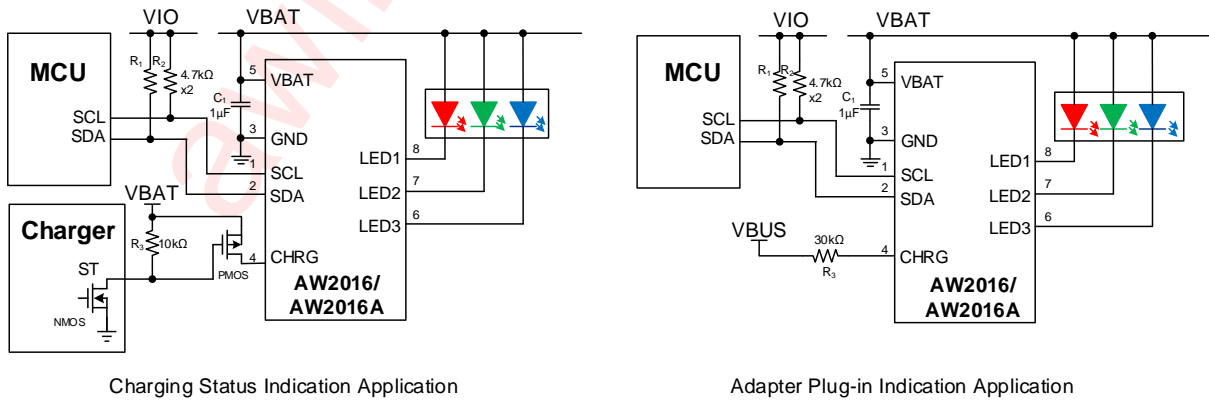

Figure 3 Functional Block Diagram

### Typical Application Circuits



Charging Status Indication Application

Adapter Plug-in Indication Application

Figure 4 Typical Application Circuits

## Ordering Information

Part Number	Temperature	Package	Marking	Moisture Sensitivity Level	Environmental Information	Delivery Form
AW2016QNR	-40°C~85°C	QFN 1.2mm×1.2mm-8L	016	MSL1	ROHS+HF	3000 units/ Tape and Reel
AW2016AQNR	-40°C~85°C	QFN 1.2mm×1.2mm-8L	16A	MSL1	ROHS+HF	3000 units/ Tape and Reel

## Absolute Maximum Ratings (NOTE 1)

PARAMETERS		RANGE
Supply voltage range VBAT		-0.3V to 6.0V
Input voltage range	SCL, SDA	-0.3V to 6.0V
	CHRG	-0.3V to 6.0V
	LED1~LED3	-0.3V to 6.0V
Output voltage range	SDA	-0.3V to 6.0V
Junction-to-ambient thermal resistance $\theta_{JA}$		122°C/W
Operating free-air temperature range		-40°C to 85°C
Maximum junction temperature $T_{JMAX}$		150°C
Storage temperature $T_{STG}$		-65°C to 150°C
Lead temperature (Soldering 10 seconds)		260°C
ESD(NOTE 2)		
HBM		±2kV
CDM		±2kV
Latch-up		
Test Condition: JEDEC EIA/JESD78E		+IT: 350mA -IT: -350mA

NOTE1: Conditions out of those ranges listed in “absolute maximum ratings” may cause permanent damages to the device. Exposure to absolute-maximum-rated conditions for prolonged periods may affect device reliability.

NOTE2: The human body model is a 100pF capacitor discharged through a 1.5kΩ resistor into each pin. Test method: MIL-STD-883J Method 3015.9(HBM) JEDEC EIA/JESD22-C101F (CDM).

## Electrical Characteristics

V<sub>BAT</sub>=3.8V, T<sub>A</sub>=25°C for typical values (unless otherwise noted)

Symbol	Description	Test Conditions	Min	Typ.	Max	Unit
<b>Power Supply</b>						
V <sub>BAT</sub>	Input operation voltage		2.5		5.5	V
I <sub>SHUTDOWN</sub>	Current in shutdown mode	SCL/SDA =0V CHRG=0V (over 130ms)			2	μA
I <sub>STANDBY</sub>	Current in standby mode	SCL/SDA=1.8V CHRG=0V		2	10	μA
I <sub>ACTIVE</sub>	Quiescent current in active mode	Register CHIPEN=1 all LEDs off		100	150	μA
V <sub>POR</sub>	Power on reset voltage		0.95	1.25	1.55	V
V <sub>UVLO</sub>	UVLO voltage	GCR2.UVTH[1:0]=00	1.75	2	2.25	V
T <sub>OTP</sub>	Over temperature threshold			140		°C
T <sub>HYS</sub>	Over temperature hysteresis			20		°C
F <sub>OSC</sub>	Oscillator frequency		-5%	1.024	+5%	MHz
<b>LED Driver</b>						
I <sub>ACC</sub>	Current accuracy	I <sub>LED</sub> =15mA	-3%		+3%	%
I <sub>MATCH</sub>	Matching accuracy	I <sub>LED</sub> =15mA	-3%		+3%	%
V <sub>DROP</sub>	Dropout voltage	I <sub>LED</sub> =15mA		50	100	mV
F <sub>PWM</sub>	PWM frequency	LCTR.FREQ=0	-5%	250	+5%	Hz
<b>Digital Logical Interface</b>						
V <sub>IL</sub>	Logic input low level	SDA, SCL			0.4	V
		CHRG			0.4	
V <sub>IH</sub>	Logic input high level	SDA, SCL	1.3			V
		CHRG	V <sub>BAT</sub> -0.2			
I <sub>IL</sub>	Low level input current	SDA, SCL		5		nA
I <sub>IH</sub>	High level input current	SDA, SCL		5		nA
V <sub>OL</sub>	Logic output low level	SDA, I <sub>OUT</sub> =3mA			0.4	V

Symbol	Description	Test Conditions	Min	Typ.	Max	Unit
$I_L$	Output leakage current	SDA open drain			1	nA

## I<sup>2</sup>C Interface Timing

Parameter Name		Min	Typ.	Max	Unit
$F_{SCL}$	Interface clock frequency			400	kHz
$T_{DEGLITCH}$	Deglitch time	SCL	200		ns
		SDA	250		ns
$T_{HD:STA}$	(Repeat-start) Start condition hold time	0.6			$\mu$ s
$T_{LOW}$	Low level width of SCL	1.3			$\mu$ s
$T_{HIGH}$	High level width of SCL	0.6			$\mu$ s
$T_{SU:STA}$	(Repeat-start) Start condition setup time	0.6			$\mu$ s
$T_{HD:DAT}$	Data hold time	0			$\mu$ s
$T_{SU:DAT}$	Data setup time	0.1			$\mu$ s
$T_R$	Rising time of SDA and SCL			0.3	$\mu$ s
$T_F$	Falling time of SDA and SCL			0.3	$\mu$ s
$T_{SU:STO}$	Stop condition setup time	0.6			$\mu$ s
$T_{BUF}$	Time between start and stop condition	1.3			$\mu$ s

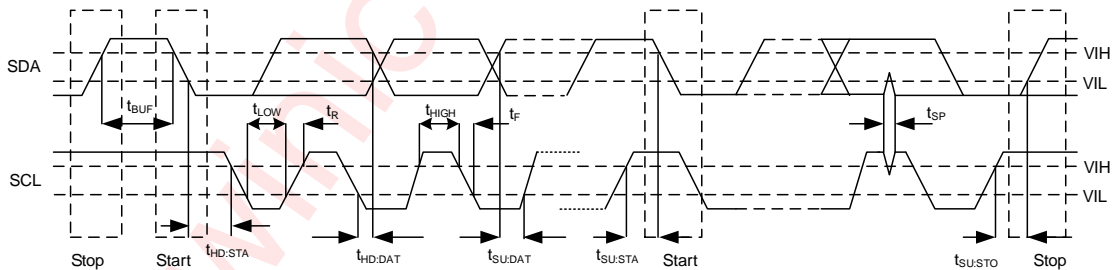

Figure 5 Timing of I<sup>2</sup>C Interface Signals

## Functional Description

### Power On Reset

When the supply voltage VBAT of AW2016/AW2016A drops below a predefined voltage  $V_{POR}$  (1.25V), the device enters shutdown mode, and generate a reset signal to perform a power-on reset operation, which will reset all control circuits and configuration registers.

The status bit ISR.PUIS (register: 0x02 bit4) will be set to 1 when power-on reset operation occurs, which will be cleared by a read operation of ISR register. Usually the ISR.PUIS bit can be used to check whether an unexpected power-on event has taken place.

### Power On Timing

To ensure that the internal configuration parameters are correctly loaded during each power-on process of AW2016/AW2016A, the power design of AW2016/AW2016A needs to follow the following power-on timing limit:

The supply voltage from 0V to VBAT requires less than 1ms in rise process, and steps are not allowed to appear during the voltage rise process.

As the following timing figure:

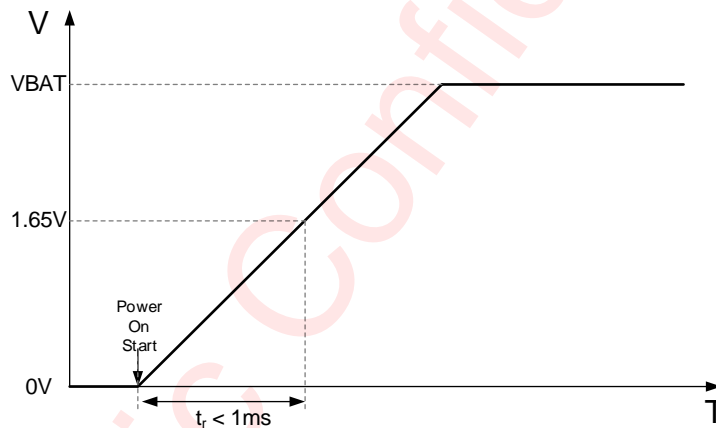

Figure 6 AW2016/AW2016A Power on Timing

### Operating Mode

In AW2016/AW2016A, pin SCL provides power down control. There are three work modes available: Shutdown, Standby and Active mode.

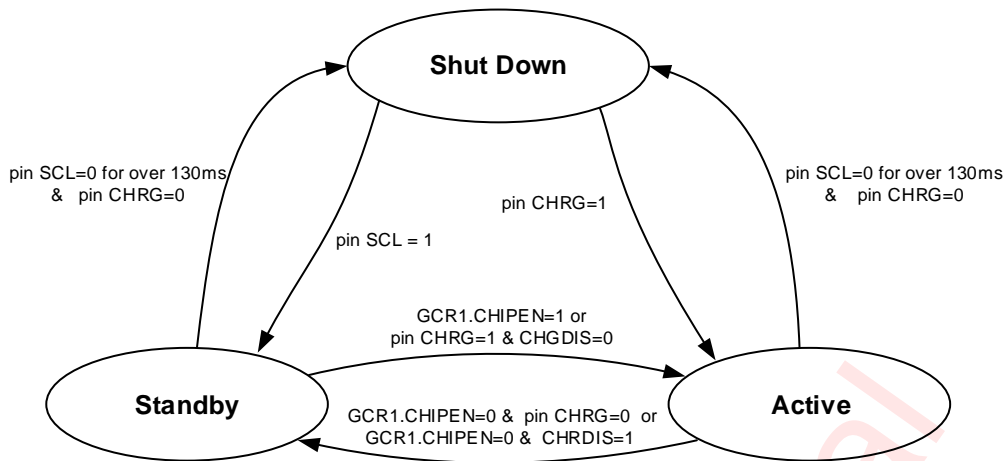

Figure 7 AW2016/AW2016A Operating Modes Transition

### Shutdown Mode

The AW2016/AW2016A enters into the shutdown mode when CHRГ is low and SCL level is pulled down to low for over 130ms.

In shutdown mode, the device reset all internal circuits and configuration registers, all internal blocks are switched off except the power-on-reset circuit and the SCL level detect circuit, and the current consumption is very low (< 2 $\mu$ A).

### Standby Mode

The device enters into standby mode when SCL level is pulled high from shutdown mode or when pin CHRГ is low and GCR1.CHIPEN become 0 in active mode.

In standby mode, only part of internal circuit work. The I<sup>2</sup>C interface is accessible, but only registers RSTR and GCR1 can be written, the internal OSC keep closed and there is not internal clock. The current consumption is less than 10 $\mu$ A.

### Active Mode

When bit CHIPEN of GCR1 register is set to 1 in standby mode or CHRГ is pulled high in shutdown mode, the device enters into active mode.

In active mode, the internal OSC works to provide clock signal. User can configure the device to produce the specified breath lighting effects in pattern mode or turn any LED on or off directly.

### Software Reset

Writing 0x55 to register RSTR (register: 0x00) via I<sup>2</sup>C interface will reset the device, including all functional circuits and configuration registers.

### Under Voltage Lock Out (UVLO)

The voltage on pin VBAT is monitored internally by the device. When voltage of VBAT drops below predefined threshold by bit GCR2.UVTH (2.0V typically), the UVLOIS flag bit in ISR register is set to "1". After a read, the flag register can be cleared.

When UVLO condition is met, the bit CHIPEN in register GCR1 will be cleared, and the device return to standby state. If VBAT rises above the threshold and GCR1.CHIPEN bit is set to "1", the device will enter into

active mode again.

If the UVDIS bit in register GCR2 is set to “1”, the internal UVLO monitor is disabled. The default value of the UVDIS bit is “0”.

If the DUVP bit in register GCR2 is set to “1”, the UVLO protection function is closed, the device keeps working even though UVLO state is detected. The default value of the DUVP bit is “0”.

### Over Temperature Protection

When the device reaches 140°C, the over-temperature protection be activated, and the OTPIS flag bit in register ISR is set to “1”, and after a read, the flag register can be cleared.

When OTP condition is met, the bit CHIPEN in register GCR1 will be cleared, and the device will be forced to standby state. Once the temperature of the device drops below 120°C, and GCR1.CHIPEN bit is set to “1”, the device will enter into active mode again.

If the OTDIS bit in register GCR2 is set to “1”, the OTP function is disabled. The default value of the OTDIS bit is “0”.

If the DOTP bit in register GCR2 is set to “1”, the OTP protection function is closed, the device keeps working even though over-temperature condition is detected. The default value of the DOTP bit is “0”.

### I<sup>2</sup>C Interface

The AW2016/AW2016A supports the I<sup>2</sup>C serial bus and data transmission protocol in fast mode at 400 kHz, and operates as a slave on the I<sup>2</sup>C bus. Connections to the bus are made via the open-drain I/O pins SCL and SDA. The pull-up resistor can be selected in the range of 1k~10kΩ and the typical value is 4.7kΩ, and interface voltage of 1.8V~3.3V are all supported.

#### Device Address

The I<sup>2</sup>C device address (7-bit) of AW2016 is 0x64, followed by the R/W bit (Read=1/Write=0).

#### Data Validation

When SCL is high level, SDA level must be constant. SDA can be changed only when SCL is low level.

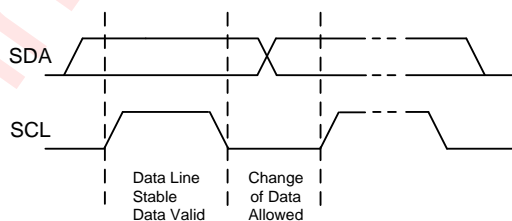

Figure 8 Data Validation Diagram

#### I<sup>2</sup>C Start/Stop

I<sup>2</sup>C start: SDA changes from high level to low level when SCL is high level.

I<sup>2</sup>C stop: SDA changes from low level to high level when SCL is high level.

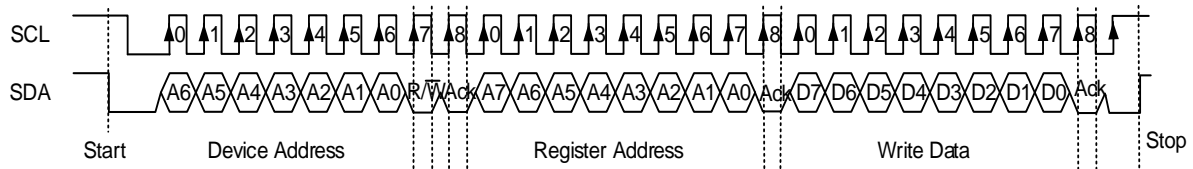
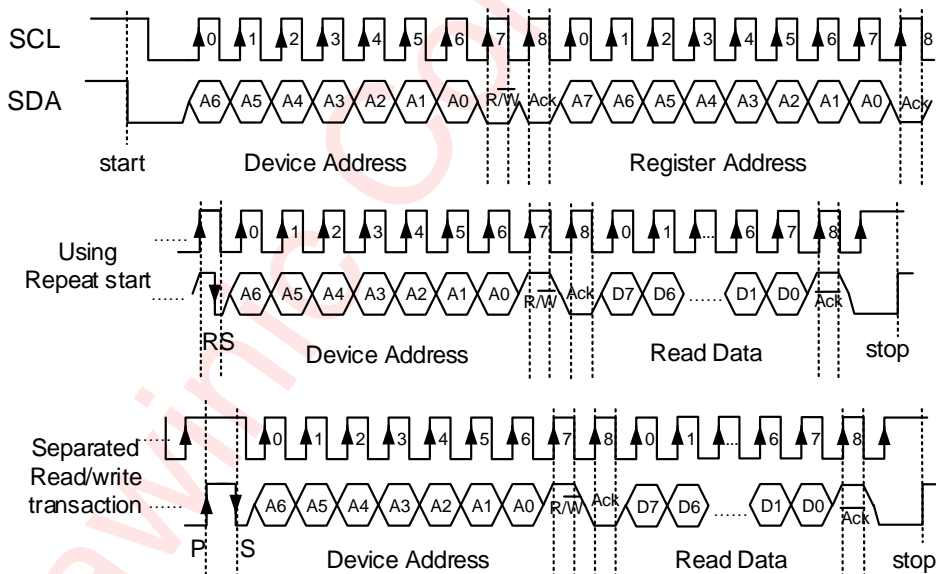

Figure 11 I<sup>2</sup>C Write Byte Cycle

### Read Cycle

In a read cycle, the following steps should be followed:

- Master device generates START condition.
- Master device sends slave address (7-bit) and the data direction bit ( $R/W = 0$ ).
- Slave device sends acknowledge signal if the slave address is correct.
- Master sends control register address (8-bit).
- Slave sends acknowledge signal.
- Master generates STOP condition followed with START condition or REPEAT START condition.
- Master device sends slave address (7-bit) and the data direction bit ( $R/W = 1$ ).
- Slave device sends acknowledge signal if the slave address is correct.
- Slave sends data byte from addressed register.
- If the master device sends acknowledge signal, the slave device will increase the control register address by one, then send the next data from the new addressed register.
- If the master device generates STOP condition, the read cycle is ended.

Figure 12 I<sup>2</sup>C Read Byte Cycle

### LED Driver

The AW2016/AW2016A has 3 LEDs drivers to drive one RGB LED or three single-color LEDs. Each LED is driven by common-anode mode constant current source with duty cycle controlled by PWM. Both current and PWM level can be configured via I<sup>2</sup>C interface.

### LED Current

Globally, the maximum output current for three LEDs is 4-level selectable among 5mA, 10mA, 15mA and

30mA via register GCR2.IMAX (register: 0x04). In general, GCR2.IMAX is used to set the max brightness of LED output.

For each LED, there is 16 current levels configurable via 4-bit register groups LCFGx.CUR (x=1~3). So in RGB application it is possible to combine into 16x16x16 color-mixing schemes totally.

### PWM Dimming Control

The LED output current source is gated by exponent 256-level PWM signal to create better dimming effect. The registers PWMx (address 0x34, 0x35, 0x36) define 8-bit PWM level for each LED.

When register PWMx being modified or working in PATTERN mode, the smooth transition effect is available by continuously adjusting PWM duty. The slope of ramp up/down, are separately set via configuring the bit4~bit7 in pattern registers LEDxT0/1 (x=1~3).

The ramping curve can be configured to be linear and exponential by setting bit3 (EXP) in register LCTR (address 0x30).

### LED Control

All LEDs in the device can be independently turned on or off via setting bit LEx (x=1~3) of register LCTR.

- LCTR.LEx=0, LEDx is switched off.
- LCTR.LEx=1, LEDx is switched on.

### Pattern Mode

When register bit LCFGx.MD (address 0x31, 0x32, 0x33, x=1~3 ) is set to "1", the corresponding LEDx operates in pattern mode.

In this mode, the LEDx is controlled by internal pattern controller to produce breathing lighting effect with user-defined timing parameter. In AW2016/AW2016A, each LED has an independent pattern controller with respective pattern parameter configuration register, and work independently.

The waveform of a breathing pattern is shown in the diagram below. The parameter T0~T4 define 4 key primary time in a complete breathing period. T0 is the delay time before pattern starting, T1~T4 composite a breathing cycle, which denote the rise-time, on-time, fall-time and off- time respectively.

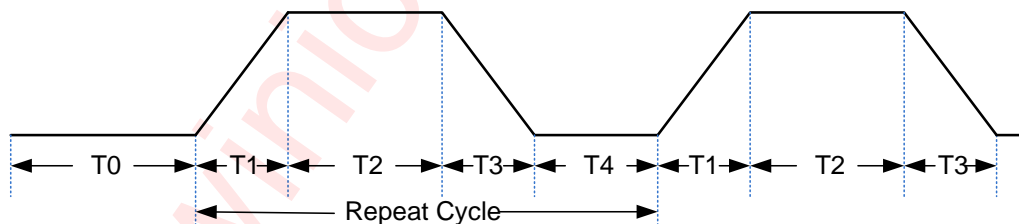

Figure 13 LED Breath Timing in Pattern Mode

The repeat times of pattern is configured by bit0~3 (REPEAT) in register LEDxT2. A pattern can repeat for pre-defined times (if LEDxT2.REPEAT is not "0000", from 1 to 15) or loop continuously (if LEDxT2.REPEAT is set to "0000").

After defined times of pattern repeat is finished, the status bit ISR.LISx (x=1~3, address 0x02) will be set to "1" automatically, which only can be cleared after reading register ISR via I<sup>2</sup>C.

In pattern mode, each channel can be configured independently. The breath effect will start once LEDxT2 is written. If user wants to sync the three channel start at the same time, please follow the following steps:

- a) Set LCTR to 00h.
- b) Set LCFGx.MD to "0".
- c) Configure LEDxT0, LEDxT1, LEDxT2 for parameters T0~T4, repeat time.

- d) Set LCFGx.MD to "1".
- e) Set LCTR to 07h.

## Manual Control Mode

When control bit LCFGx.MD (register: 0x31, 0x32, 0x33 bit4) is set to 0, the corresponding LEDx is work in manual control mode.

In manual control mode, the pattern controller is disable and the LED is directly controlled by setting current/PWM level register via I<sup>2</sup>C interface.

In manual control mode, smooth dimming is supported. If LCFGx.FO (address 0x31, 0x32 0x33, bit6) is set to 1, automatic fade-out is enabled. If LCFGx.FI (register: 0x31, 0x32, 0x33 bit5) is set to 1, automatic fade-in is enabled. If a new value is set on register PWMx when LCFGx.FI and/or LCFGx.FO is set, the brightness of LED output ramp up/down smoothly, with its transition time defined by parameter T1,T3sourced from corresponding pattern configuration (LEDxT0 and LEDxT1).

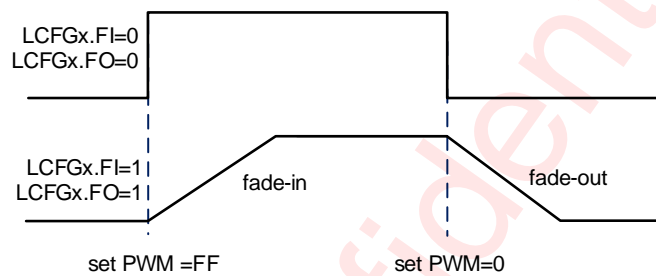

Figure 14 Manual Control Mode

## Sync Control Mode

In order to simplify configuration and control in the case of all LEDs synchronously dimming, especially in application of RGB LED, the AW2016/AW2016A can be configured to work on sync control mode.

When LCFG1.SYNC is set to 1, the device works in sync control mode. In this mode, user can control all LEDs to turn on, turn off, or output breathing lighting synchronously by controlling LED1 only.

In sync control mode, the output currents of all LEDs are still defined via register LCFGx.CUR individually, but their PWM levels of LED2, LED3 are both sourced from LED1, the setting of register PWM2, PWM3 are ignored. The control bit LCFG1.MD defines operating mode globally for all LEDs. If LCFG1.MD is 0, manual mode is selected for all LEDs, user can set all LEDs on or off by simply setting register PWM1, and fade-in or fade-out effect are selected by bit LCFG1.FI and LCFG1.FO. If register LCFG1.MD is set 1, all LEDs work in pattern mode, user only need to configured and control the pattern of LED1.

## Auto Charging Indication

In application of mobile phone, when battery voltage is too low and the PMU cannot work, the LED driver cannot be controlled by application processor via I<sup>2</sup>C interface. In this case, extra LED control circuit is necessary to be built in for charging status indication.

Both AW2016 and/AW2016A provide the auto charging indication function for low battery voltage application. When the external USB power is inserts to phone, the pin CHRG is pulled high, the AW2016/AW2016A will enter active state automatically. The predefined pattern output only on pin LED1, the LED2 and LED3 keep off status.

## AW2016:

The pattern parameter of AW2016 is showed in figure below. The maximum current is 6mA, breathing period is about 4.5s.

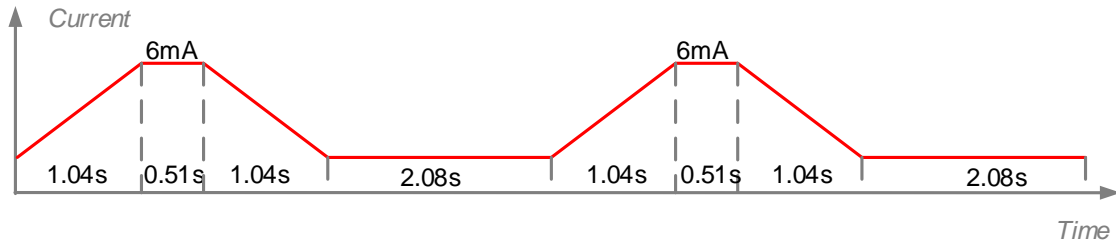

Figure 15 AW2016 Auto Charging Indication Pattern Parameter

#### AW2016A:

The pattern parameter of AW2016A is showed in figure below. The led current is 3mA.



Figure 16 AW2016A Auto Charging Indication Pattern Parameter

Once the CHRГ pin goes low, the device comes back to shutdown state again and stops LED1 output.

The auto charging indication function should be closed by configured register GCR1.CHGDIS (register: 0x01 bit1) to 1 when the processor is able to configure AW2016 via I<sup>2</sup>C interface, then the lighting effects will have no relation with the CHRГ status.

When special charger IC is used and pin CHRГ is recommend to be connected to status pin of charger IC, the pin LED1 can indicate the real battery charging status.

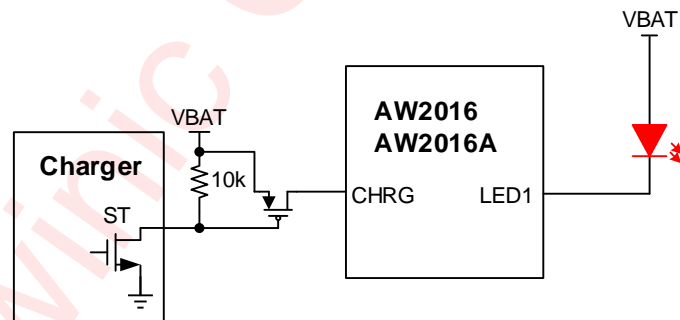

Figure 17 Real Charging Status Indication in Special Charger IC Application

When no charger IC is applied, and battery charging is managed by PMU, no real charging status signal can be adapted, so the LED1 status can only indicate whether the USB power is plugged in or not.

When the external resistance between VBUS and pin CHRГ is 30kΩ, the voltage range of VBUS can be 5V ~15V.

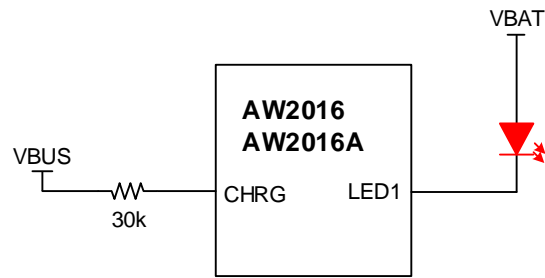

Figure 18 USB Power Insertion Status Indication in PMU-Controlled Charging Application

awinic Confidential

**Register Description****Register List**

Addr	Name	W/R	Bit7	Bit 6	Bit 5	Bit 4	Bit 3	Bit 2	Bit 1	Bit 0
00h	RSTR	WR	0	0	0	0	1	0	0	1
01h	GCR1	WR	LIE3	LIE2	LIE1		UVLOIE	OTPIE	CHGDIS	CHIPEN
02h	ISR	R	LIS3	LIS2	LIS1	PUIS	UVLOIS	OTPIIS	-	-
03h	PATST	R	0	0	0	0	0	ST3	ST2	ST1
04h	GCR2	WR	DUVP	DOTP	UVDIS	OTDIS	UVTH		IMAX	
30h	LCTR	WR	-	-	FREQ	-	EXP	LE3	LE2	LE1
31h	LCFG1	WR	SYNC	FO	FI	MD	CUR			
32h	LCFG2	WR	-	FO	FI	MD	CUR			
33h	LCFG3	WR	-	FO	FI	MD	CUR			
34h	PWM1	WR	PWM							
35h	PWM2	WR	PWM							
36h	PWM3	WR	PWM							
37h	LED1T0	WR	T1				T2			
38h	LED1T1	WR	T3				T4			
39h	LED1T2	WR	T0				REPEAT			
3Ah	LED2T0	WR	T1				T2			
3Bh	LED2T1	WR	T3				T4			
3Ch	LED2T2	WR	T0				REPEAT			
3Dh	LED3T0	WR	T1				T2			
3Eh	LED3T1	WR	T3				T4			
3Fh	LED3T2	WR	T0				REPEAT			

**Detailed Register Description****RSTR, Chip ID and Software Reset Register**

Address: 0x00, R/W, default: 0x09

7	6	5	4	3	2	1	0
D7	D6	D5	D4	D3	D2	D1	D0

Bit	Symbol	Description
7:0	RSTR	Read: Chip ID, 0x09 Write: Write 0x55 to RSTR, reset internal logic and register

**GCR1, Global Control Register**

Address: 0x01, R/W, default: 0x00

7	6	5	4	3	2	1	0
LIE3	LIE2	LIE1	-	UVLOIE	OTPIE	CHGDIS	CHIPEN

Bit	Symbol	Description
7:5	LIEx	LEDx interrupt enable 0: Disable LEDx interrupt (default) 1: Enable LEDx interrupt
4	-	Reserved
3	UVLOIE	UVLO interrupt enable 0: Disable UVLO interrupt (default) 1: Enable UVLO interrupt
2	OTPIE	Over temperature interrupt enable

		0: Disable OT interrupt (default) 1: Enable OT interrupt
1	CHGDIS	Disable auto charge indication function 0: Enable auto charge indication function (default) 1: Disable auto charge indication function
0	CHIPEN	Device operating enable 0: Disable, the device is in standby state (default) 1: Enable, the device enters active state

**ISR, Chip Status Register**

Address: 0x02, Read only, Cleared after Read, default: 0x10

7	6	5	4	3	2	1	0
LIS3	LIS2	LIS1	PUIS	UVLOIS	OTPIS	-	-

Bit	Symbol	Description
7:5	LISx	LEDx interrupt status
4	PUIS	Power up interrupt status 0: No power-up reset has taken place 1: Power-up reset has taken place
3	UVLOIS	UVLO detection status 0: No UVLO detected 1: UVLO detected
2	OTIS	Over-temperature detection status 0: No over-temperature detected 1: Over-temperature detected
1-0	-	Reserved

**PATST, Pattern Status Register**

Address: 0x03, Read only, default: 0x00

7	6	5	4	3	2	1	0
-	-	-	-	-	ST3	ST2	ST1

Bit	Symbol	Description
7:3	-	Reserved
2	ST3	LED3 pattern status 0: Pattern is not running 1: Pattern is running
1	ST2	LED2 pattern status 0: Pattern is not running 1: Pattern is running
0	ST1	LED1 pattern status 0: Pattern is not running 1: Pattern is running

**GCR2, LED Maximum Current Register**

Address: 0x04, R/W, default: 0x00

7	6	5	4	3	2	1	0
DUVP	DOTP	UVDIS	OTDIS	UVTH		IMAX	

Bit	Symbol	Description
7	DUVP	Disable UVLO protection 0: Enable UVLO protection, reset CHIPEN when UVLOIS=1 (default) 1: Disable UVLO protection
6	DOTP	Disable over temperature protection 0: Enable OTP protection, reset CHIPEN when OTPIS=1 (default) 1: Disable OTP protection
5	UVDIS	Disable UVLO detection function 0: Enable UVLO detection (default) 1: Disable UVLO detection
4	OTDIS	Disable over temperature detection function 0: Enable over-temperature detection (default) 1: Disable over-temperature detection
3:2	UVTH	UVLO threshold selection 00: 2.0V (default) 01: 2.1V 10: 2.2V 11: 2.2V
1:0	IMAX	Global max output current selection 00: I <sub>max</sub> =15mA (default) 01: I <sub>max</sub> =30mA 10: I <sub>max</sub> =5mA 11: I <sub>max</sub> =10mA

**LCTR, LED Control Register**

Address: 0x30, R/W, default: 0x00

7	6	5	4	3	2	1	0
-	-	FREQ	-	EXP	LE3	LE2	LE1

Bit	Symbol	Description
5	FREQ	PWM carrier frequency selection 0: 250Hz (default) 1: 125Hz
4	-	Reserved
3	EXP	PWM transition mode Selection 0: Exponential transition (default) 1: Linear transition
2	LE3	LED3 enable 0: LED3 module stop work and LED3 out disable (default) 1: LED3 output is enabled
1	LE2	LED2 enable 0: LED2 module stop work and LED2 out disable (default) 1: LED2 output is enabled
0	LE1	LED1 enable 0: LED1 module stop work and LED1 out disable (default) 1: LED1 output is enabled

**LCFG1, LED1 Mode Configuration Register**

LCFG1: Address: 0x31, R/W, default: 0x00

7	6	5	4	3	2	1	0
SYNC	FO	FI	MD	CUR			

Bit	Symbol	Description
7	SYNC	Sync mode enable 0: Independently control mode (default) 1: Sync control mode
6	FO	Fade-out enable control, only active in manual mode 0: Disable PWM fade-out (default) 1: Enable PWM fade-out, the dimming time defined by T3
5	FI	Fade-in enable control, only active in manual mode 0: Disable PWM fade-in (default) 1: Enable PWM fade-in, the dimming time defined by T1
4	MD	LED1 operating mode select. 0: Manual mode (default) 1: Pattern mode
3:0	CUR	LED1 output current setting. LED1 output current $I_o = I_{max} * CUR / 15$ (mA) when PWM1 is 255.

**LCFG2, LED2 Mode Configuration Register**

LCFG1: Address: 0x32, R/W, default: 0x00

7	6	5	4	3	2	1	0
-	FO	FI	MD	CUR			

Bit	Symbol	Description
6	FO	Fade-out enable control, only active in manual mode 0: Disable PWM fade-out (default) 1: Enable PWM fade-out, the dimming time defined by T3
5	FI	Fade-in enable control, only active in manual mode 0: Disable PWM fade-in (default) 1: Enable PWM fade-in, the dimming time defined by T1
4	MD	LED2 operating mode select. 0: Manual mode (default) 1: Pattern mode
3:0	CUR	LED2 output current setting. LED2 output current $I_o = I_{max} * CUR / 15$ (mA) when PWM2 is 255.

**LCFG3, LED3 Mode Configuration Register**

LCFG2: Address: 0x33, R/W, default: 0x00

7	6	5	4	3	2	1	0
-	FO	FI	MD	CUR			

Bit	Symbol	Description
6	FO	Fade-out enable control, only active in manual mode 0: Disable PWM fade-out (default)

		1: Enable PWM fade-out, the dimming time defined by T3
5	FI	Fade-in enable control, only active in manual mode 0: Disable PWM fade-in (default) 1: Enable PWM fade-in, the dimming time defined by T1
4	MD	LED3 operating mode select. 0: Manual mode (default) 1: Pattern mode
3:0	CUR	LED3 output current setting. LED3 output current $I_o = I_{max} * CUR / 15$ (mA) when PWM3 is 255.

**PWM1/PWM2/PWM3 , PWM Dimming Level Register**

PWM1: Address: 0x34, R/W, default:0x00

PWM2: Address: 0x35, R/W, default:0x00

PWM3: Address: 0x36, R/W, default:0x00

7	6	5	4	3	2	1	0
PWM							

Bit	Symbol	Description
7:0	PWM	PWM level for LEDx (x=1~3)

**LEDxT0, T1 & T2 Configuration Register**

LED1T0: Address: 0x37, R/W, default: 0x00

LED2T0: Address: 0x3A, R/W, default: 0x00

LED3T0: Address: 0x3D, R/W, default: 0x00

7	6	5	4	3	2	1	0
T1				T2			

Bit	Symbol	Description																																
7:4	T1	T1 (Rise- time) selection <table> <tr><td>0000:</td><td>0.00s (default)</td><td>1000:</td><td>2.1s</td></tr> <tr><td>0001:</td><td>0.13s</td><td>1001:</td><td>2.6s</td></tr> <tr><td>0010:</td><td>0.26s</td><td>1010:</td><td>3.1s</td></tr> <tr><td>0011:</td><td>0.38s</td><td>1011:</td><td>4.2s</td></tr> <tr><td>0100:</td><td>0.51s</td><td>1100:</td><td>5.2s</td></tr> <tr><td>0101:</td><td>0.77s</td><td>1101:</td><td>6.2s</td></tr> <tr><td>0110:</td><td>1.04s</td><td>1110:</td><td>7.3s</td></tr> <tr><td>0111:</td><td>1.6s</td><td>1111:</td><td>8.3s</td></tr> </table>	0000:	0.00s (default)	1000:	2.1s	0001:	0.13s	1001:	2.6s	0010:	0.26s	1010:	3.1s	0011:	0.38s	1011:	4.2s	0100:	0.51s	1100:	5.2s	0101:	0.77s	1101:	6.2s	0110:	1.04s	1110:	7.3s	0111:	1.6s	1111:	8.3s
0000:	0.00s (default)	1000:	2.1s																															
0001:	0.13s	1001:	2.6s																															
0010:	0.26s	1010:	3.1s																															
0011:	0.38s	1011:	4.2s																															
0100:	0.51s	1100:	5.2s																															
0101:	0.77s	1101:	6.2s																															
0110:	1.04s	1110:	7.3s																															
0111:	1.6s	1111:	8.3s																															
3:0	T2	T2 (On-time) selection <table> <tr><td>0000:</td><td>0.04s (default)</td><td>1000:</td><td>2.1s</td></tr> <tr><td>0001:</td><td>0.13s</td><td>1001:</td><td>2.6s</td></tr> <tr><td>0010:</td><td>0.26s</td><td>1010:</td><td>3.1s</td></tr> <tr><td>0011:</td><td>0.38s</td><td>1011:</td><td>4.2s</td></tr> <tr><td>0100:</td><td>0.51s</td><td>1100:</td><td>5.2s</td></tr> <tr><td>0101:</td><td>0.77s</td><td>1101:</td><td>6.2s</td></tr> </table>	0000:	0.04s (default)	1000:	2.1s	0001:	0.13s	1001:	2.6s	0010:	0.26s	1010:	3.1s	0011:	0.38s	1011:	4.2s	0100:	0.51s	1100:	5.2s	0101:	0.77s	1101:	6.2s								
0000:	0.04s (default)	1000:	2.1s																															
0001:	0.13s	1001:	2.6s																															
0010:	0.26s	1010:	3.1s																															
0011:	0.38s	1011:	4.2s																															
0100:	0.51s	1100:	5.2s																															
0101:	0.77s	1101:	6.2s																															

0110:	1.04s	1110:	7.3s
0111:	1.6s	1111:	8.3s

**LEDxT1, T3 & T4 Configuration Register**

LED1T1: Address: 0x38, R/W, default: 0x00

LED2T1: Address: 0x3B, R/W, default: 0x00

LED3T1: Address: 0x3E, R/W, default: 0x00

7	6	5	4	3	2	1	0
T3				T4			

Bit	Symbol	Description
7:4	T3	T3 (Fall-time) selection
		0000: 0.00s (default)    1000: 2.1s
		0001: 0.13s            1001: 2.6s
		0010: 0.26s            1010: 3.1s
		0011: 0.38s            1011: 4.2s
		0100: 0.51s            1100: 5.2s
		0101: 0.77s            1101: 6.2s
		0110: 1.04s            1110: 7.3s
		0111: 1.6s             1111: 8.3s
3:0	T4	T4 (Off-time) selection
		0000: 0.04s (default)    1000: 2.1s
		0001: 0.13s            1001: 2.6s
		0010: 0.26s            1010: 3.1s
		0011: 0.38s            1011: 4.2s
		0100: 0.51s            1100: 5.2s
		0101: 0.77s            1101: 6.2s
		0110: 1.04s            1110: 7.3s
		0111: 1.6s             1111: 8.3s

**LEDxT2, T0 & Repeat Times Configuration Register**

LED1T2: Address: 0x39, R/W, default: 0x00

LED2T2: Address: 0x3C, R/W, default: 0x00

LED3T2: Address: 0x3F, R/W, default: 0x00

7	6	5	4	3	2	1	0
T0				REPEAT			

Bit	Symbol	Description
7:4	T0	T0 (Delay time of pattern startup) selection
		0000: 0.04s (default)    1000: 2.1s
		0001: 0.13s            1001: 2.6s
		0010: 0.26s            1010: 3.1s

0011:	0.38s	1011:	4.2s
0100:	0.51s	1100:	5.2s
0101:	0.77s	1101:	6.2s
0110:	1.04s	1110:	7.3s
0111:	1.6s	1111:	8.3s

3:0 REPEAT Pattern repeat time

0000: Don't stop  
0001: Pattern run 1 time  
0010: Pattern run 2 times  
.....  
1111: Pattern run 15 times

awinic Confidential

## Tape And Reel Information

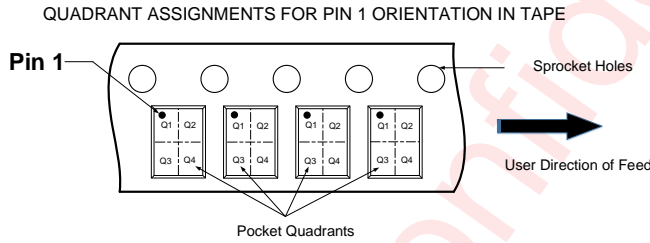
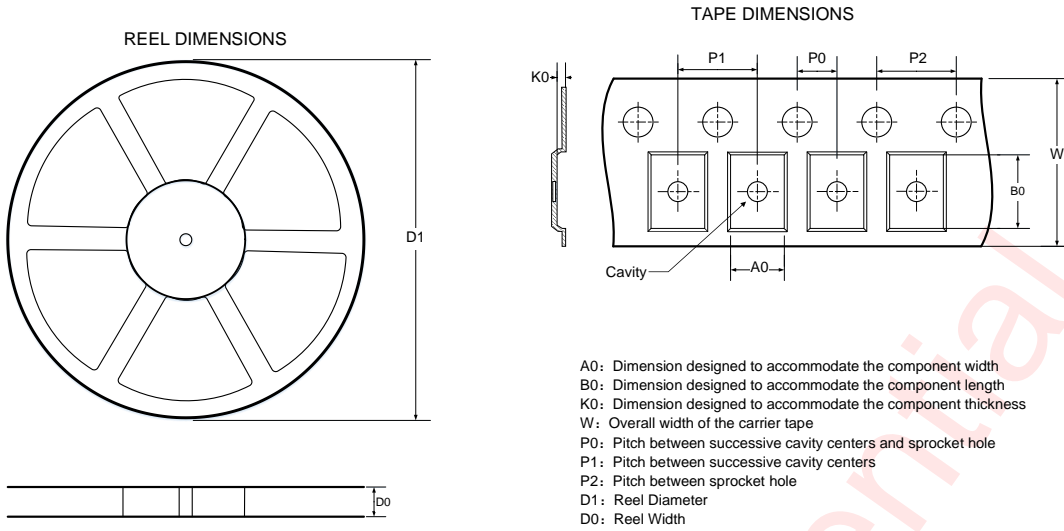

DIMENSIONS AND PIN1 ORIENTATION

D1 (mm)	D0 (mm)	A0 (mm)	B0 (mm)	K0 (mm)	P0 (mm)	P1 (mm)	P2 (mm)	W (mm)	Pin1 Quadrant
178	8.4	1.37	1.37	0.55	2	4	4	8	Q1

All dimensions are nominal

## Package Description

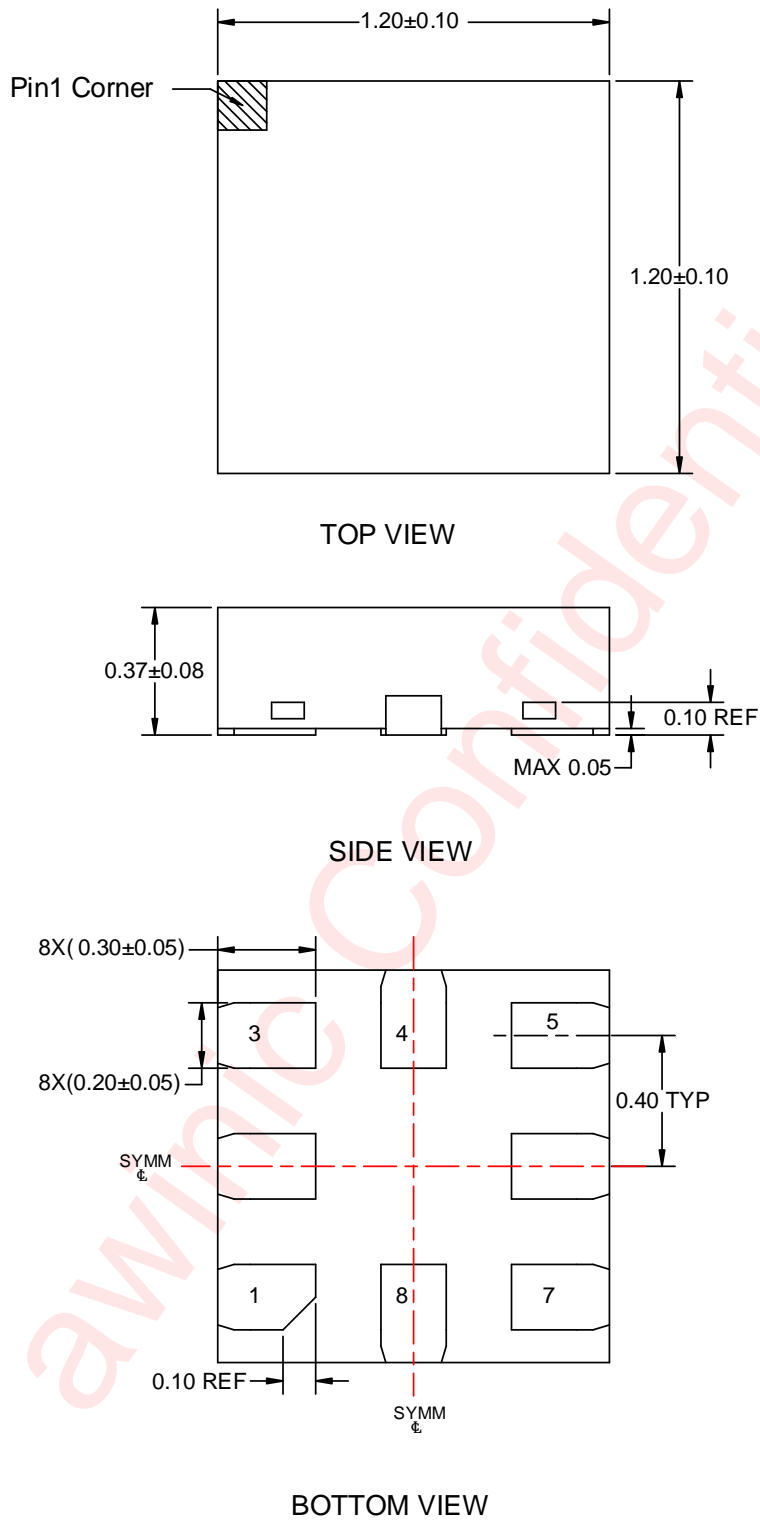

Unit: mm

### Land Pattern Data

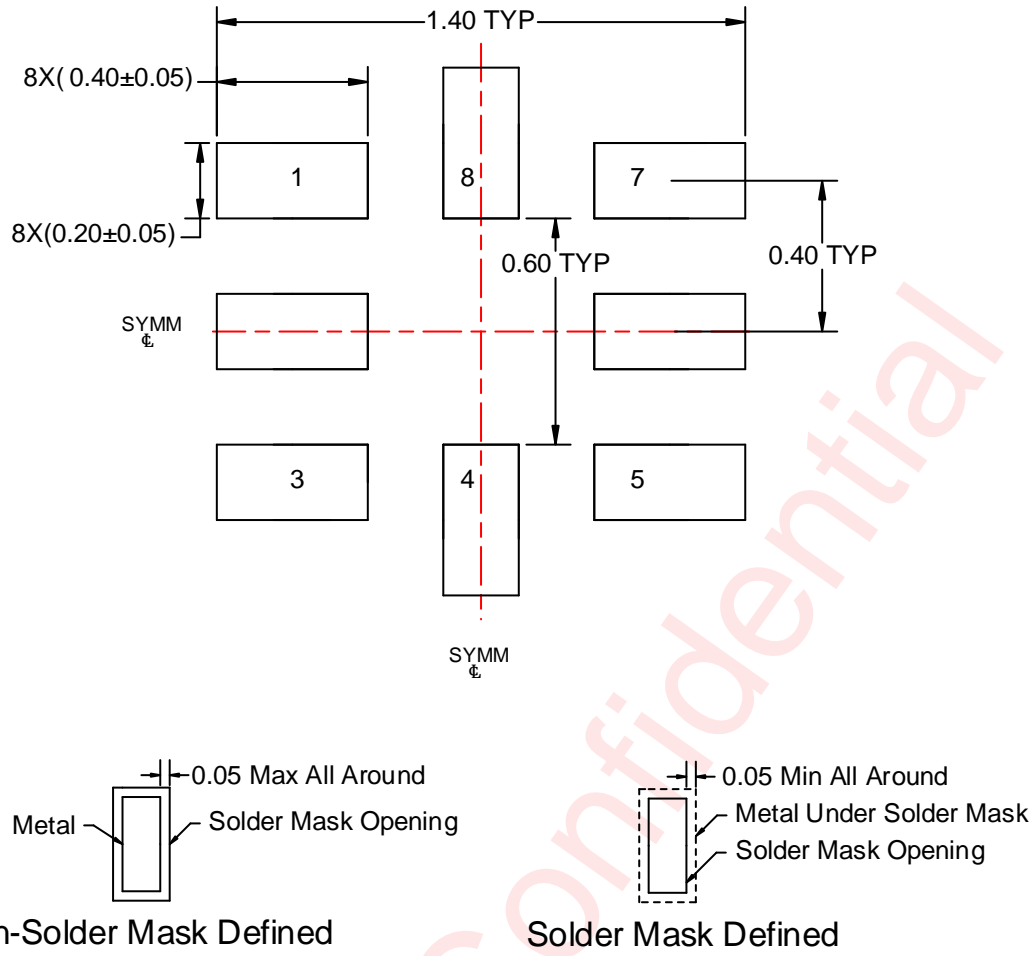

Unit: mm

## Reflow

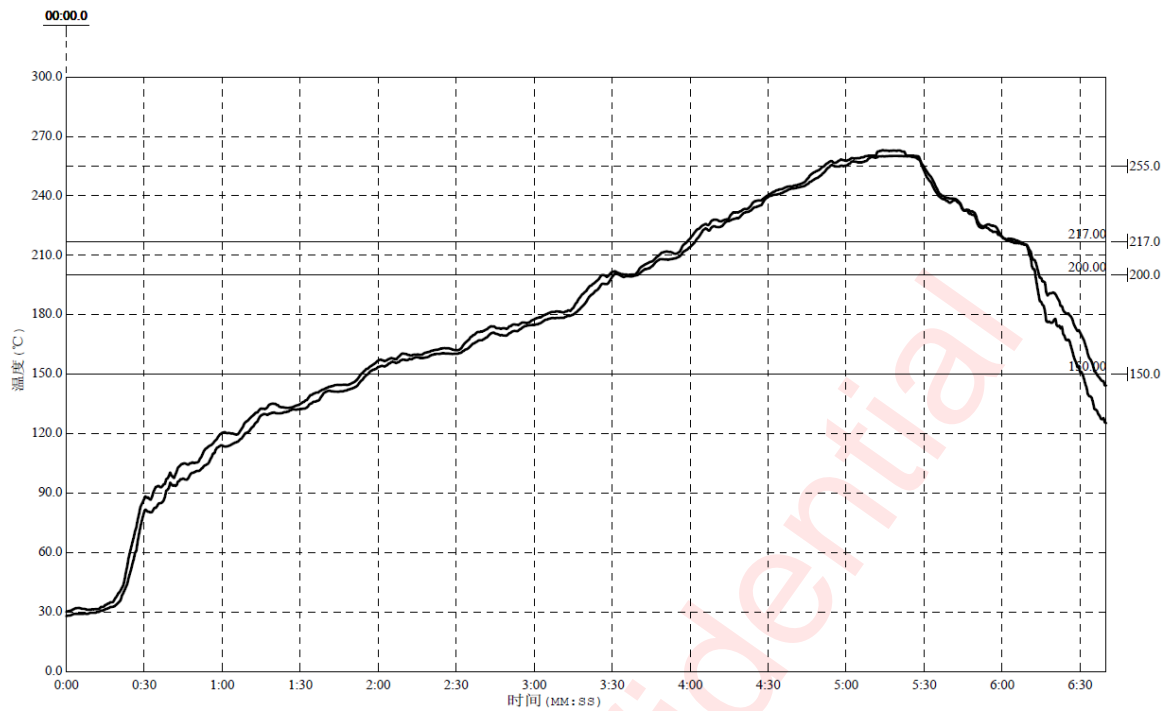

Figure 17 Package Reflow Oven Thermal Profile

Reflow Note	Spec
Average ramp-up rate (217°C to Peak)	Max. 3°C/sec
Time of preheat temp. (from 150°C to 200°C)	60-120sec
Time to be maintained above 217°C	60-150sec
Peak Temperature	>260°C
Time within 5°C of actual peak temp	20-40sec.
Ramp-down rate	Max. 6°C/sec
Time from 25°C to peak temp	Max. 8min.

## Revision History

Version	Date	Revision Record
V1.0	May 2017	Datasheet V1.0 Released
V1.1	Nov. 2017	Modify the typical application circuit --page 1,3 Modify $F_{PWM}=250\text{Hz}$ --page 6
V1.2	June 2019	Update the electrical characteristics
V1.3	Oct 2023	Add the part of Applications (P1). Delete the MM parameter (P5). Add power on timing limit description and parameters (P7). Modify the format.

## Disclaimer

Information in this document is believed to be accurate and reliable. However, Shanghai AWINIC Technology Co., Ltd (AWINIC Technology) does not give any representations or warranties, expressed or implied, as to the accuracy or completeness of such information and shall have no liability for the consequences of use of such information.

AWINIC Technology reserves the right to make changes to information published in this document, including without limitation specifications and product descriptions, at any time and without notice. Customers shall obtain the latest relevant information before placing orders and shall verify that such information is current and complete. This document supersedes and replaces all information supplied prior to the publication hereof.

AWINIC Technology products are not designed, authorized or warranted to be suitable for use in medical, military, aircraft, space or life support equipment, nor in applications where failure or malfunction of an AWINIC Technology product can reasonably be expected to result in personal injury, death or severe property or environmental damage. AWINIC Technology accepts no liability for inclusion and/or use of AWINIC Technology products in such equipment or applications and therefore such inclusion and/or use is at the customer's own risk.

Applications that are described herein for any of these products are for illustrative purposes only. AWINIC Technology makes no representation or warranty that such applications will be suitable for the specified use without further testing or modification.

All products are sold subject to the general terms and conditions of commercial sale supplied at the time of order acknowledgement.

Nothing in this document may be interpreted or construed as an offer to sell products that is open for acceptance or the grant, conveyance or implication of any license under any copyrights, patents or other industrial or intellectual property rights.

Reproduction of AWINIC information in AWINIC data books or data sheets is permissible only if reproduction is without alteration and is accompanied by all associated warranties, conditions, limitations, and notices. AWINIC is not responsible or liable for such altered documentation. Information of third parties may be subject to additional restrictions.

Resale of AWINIC components or services with statements different from or beyond the parameters stated by AWINIC for that component or service voids all express and any implied warranties for the associated AWINIC component or service and is an unfair and deceptive business practice. AWINIC is not responsible or liable for any such statements.