



## Xtrinsic MMA16xxKW DSI Inertial Sensor

The MMA16xxKW family, a SafeAssure solution, includes the DSI2.5 compatible overdamped Z-axis satellite accelerometers.

### Features

- $\pm 50g$  to  $\pm 312.5g$  Nominal Full-Scale Range
- Selectable 180 Hz, 2-pole, 400 Hz, 4-pole, or 800 Hz, 4-pole LPF
- DSI2.5 Compatible with full support of Mandatory Commands
- Internal High Side Bus Switch for DSI2.5 Daisy Chain Applications
- 16  $\mu s$  internal sample rate, with interpolation to 1 ms
- $-40^{\circ}C$  to  $125^{\circ}C$  Operating Temperature Range
- Pb-Free 16-Pin QFN, 6 by 6 Package
- Qualified AECQ100, Revision G, Grade 1 ( $-40^{\circ}C$  to  $+125^{\circ}C$ )  
(<http://www.aecouncil.com/>)

### Typical Applications

- Airbag Front and Side Crash Detection

## MMA16xxKW

### Bottom View

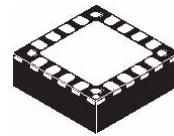

16-PIN QFN  
CASE 2086-01

### Top View

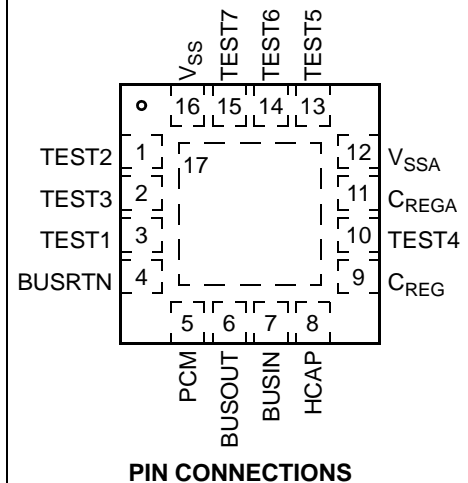

### ORDERING INFORMATION

Device	Axis	Range	Package	Shipping
MMA1605KW	Z	50g	2086-01	Tubes
MMA1606KW	Z	62.5g	2086-01	Tubes
MMA1612KW	Z	125g	2086-01	Tubes
MMA1618KW	Z	187g	2086-01	Tubes
MMA1631KW	Z	312g	2086-01	Tubes
MMA1605KWR2	Z	50g	2086-01	Tape & Reel
MMA1606KWR2	Z	62.5g	2086-01	Tape & Reel
MMA1612KWR2	Z	125g	2086-01	Tape & Reel
MMA1618KWR2	Z	187g	2086-01	Tape & Reel
MMA1631KWR2	Z	312g	2086-01	Tape & Reel

For user register array programming, please consult your Freescale representative.

## Application Diagram

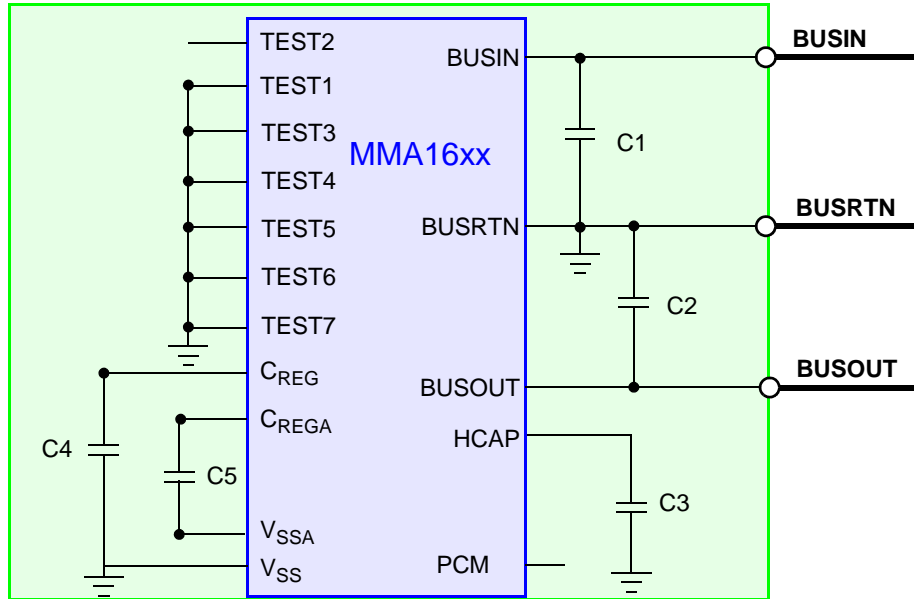

Figure 1. Application Diagram

Table 1. External Component Recommendations

Ref Des	Type	Description	Purpose
C1	Ceramic	$100 \text{ pF} \leq C1 \leq 1500 \text{ pF}$ 10%, 50V, X7R	BUSIN Power Supply Decoupling, ESD
C2	Ceramic	$100 \text{ pF} \leq C2 \leq 1500 \text{ pF}$ 10%, 50V, X7R	BUSOUT Power Supply Decoupling, ESD
C3	Ceramic, Tantalum	$1 \text{ }\mu\text{F} \leq C3 \leq 100 \text{ }\mu\text{F}$ 10%, 50V, X7R	Reservoir Capacitor for Keep Alive during Signaling
C4	Ceramic	$1 \text{ }\mu\text{F}$ 10%, 10V, X7R	Voltage Regulator Output Capacitor ( $C_{REG}$ )
C5	Ceramic	$1 \text{ }\mu\text{F}$ 10%, 10V, X7R	Voltage Regulator Output Capacitor ( $C_{REGA}$ )

## Device Orientation

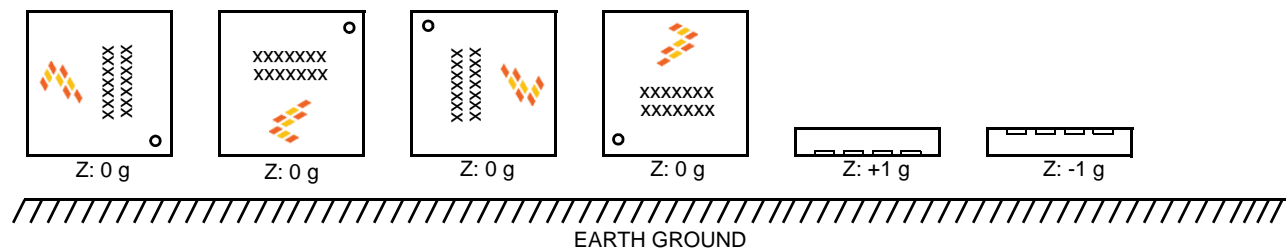

Figure 2. Device Orientation Diagram

# Internal Block Diagram

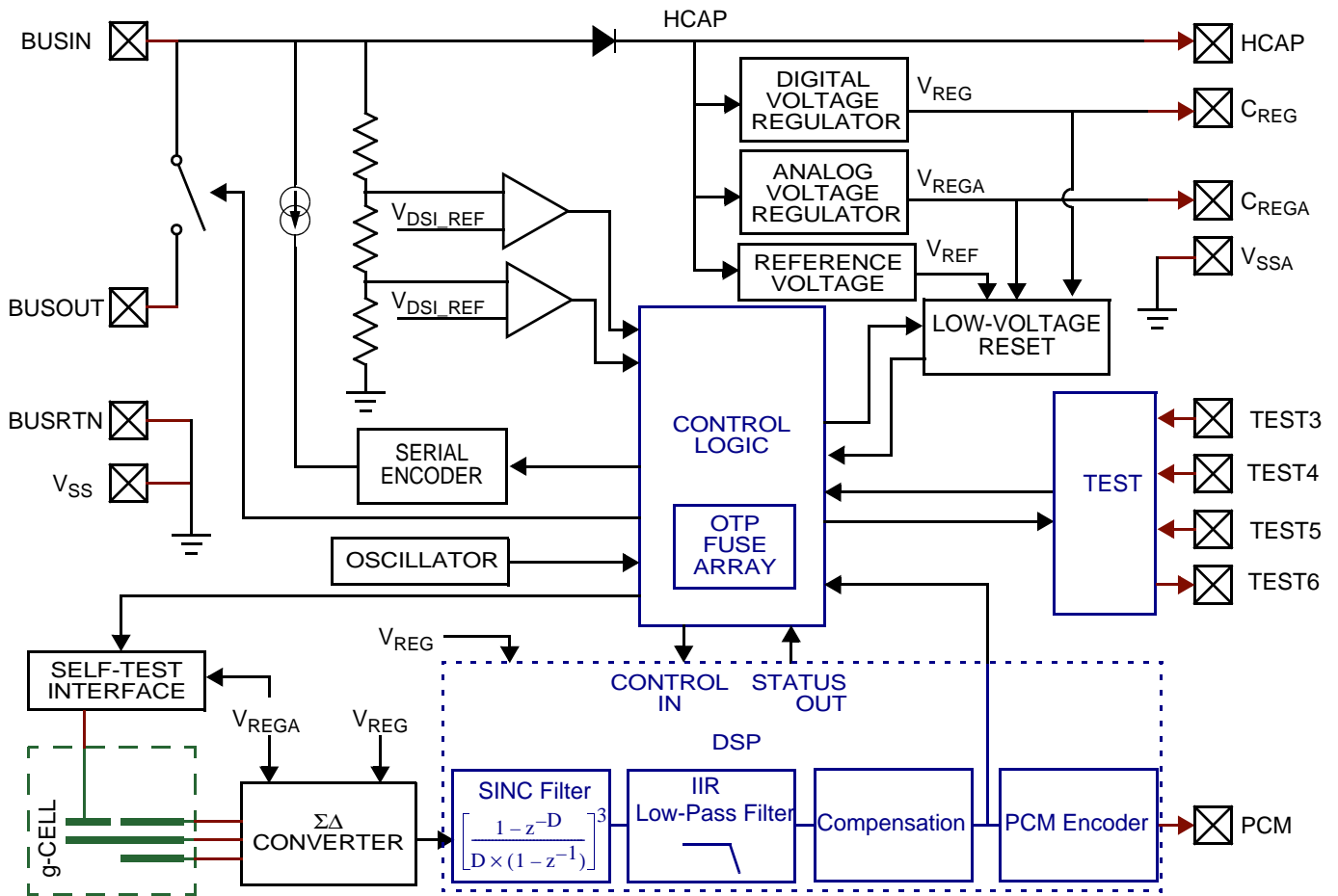

Figure 3. Block Diagram9

# 1 Pin Connections

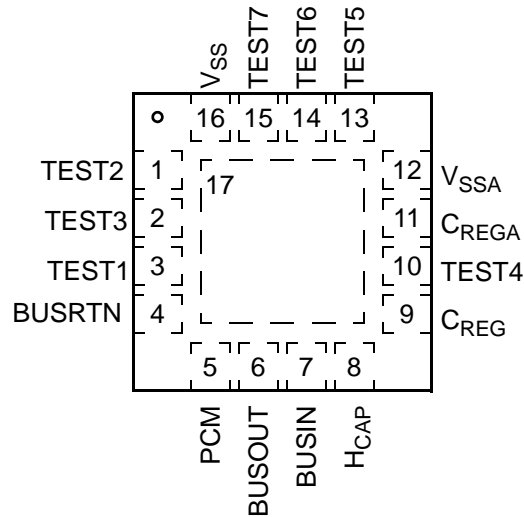

Figure 4. Pinout

Table 2. Pin Description

Pin	Pin Name	Formal Name	Definition
1	TEST2	Test Pin	This pin must be left unconnected in the application.
2	TEST3	Test Pin	This pin must be grounded in the application.
3	TEST1	Test Pin	This pin must be grounded in the application.
4	BUSRTN	Ground	This pin is the common return for power and signalling.
5	PCM	PCM Output	This pin provides a 4 MHz PCM signal proportional to the acceleration data for test purposes. The output can be enabled or disabled via OTP. If unused, this pin must be left unconnected in the application. Reference <a href="#">Section 3.5.3.6</a> .
6	BUSOUT	BUS output	This pin is internally connected to BUSIN through a switch. For daisy chain configurations, this pin is connected to the BUSIN pin of the next slave on the DSI bus. The internal bus switch is open following reset, and is closed when an Initialization command is received.
7	BUSIN	Supply / Comm	This pin is connected to the DSI positive bus node and provides the power supply and communication to the system master. An external capacitor must be connected to between this pin and the BUSRTN pin. Reference <a href="#">Figure 1</a> .
8	HCAP	Hold Capacitor	This pin rectifies the supply voltage on the BUSIN pin to create the supply voltage for the device. An external capacitor must be connected between this pin and the BUSRTN pin to store energy for operation during master communication signalling. Reference <a href="#">Figure 1</a> .
9	C <sub>REG</sub>	Digital Supply	This pin is connected to the power supply for the internal digital circuitry. An external capacitor must be connected between this pin and V <sub>SS</sub> . Reference <a href="#">Figure 1</a> .
10	TEST4	Test Pin	This pin must be grounded in the application.
11	C <sub>REGA</sub>	Analog Supply	This pin is connected to the power supply for the internal analog circuitry. An external capacitor must be connected between this pin and V <sub>SSA</sub> . Reference <a href="#">Figure 1</a> .
12	VSSA	Analog GND	This pin is the power supply return node for analog circuitry.
13	TEST5	Test Pin	This pin enables test mode, and provides the SPI programming voltage in test mode. This pin is must be grounded in the application.
14	TEST6	Test Pin	This pin must be grounded in the application.
15	TEST7	Test Pin	This pin must be grounded in the application.
16	V <sub>SS</sub>	Digital GND	This pin is the power supply return node for the digital circuitry.
17	PAD	Die Attach Pad	This pin is the die attach flag, and should be connected to V <sub>SS</sub> in the application. Reference <a href="#">Section 5</a> .
	Corner Pads	Corner Pads	The corner pads are internally connected to V <sub>SS</sub> .

## 2 Electrical Characteristics

### 2.1 Maximum Ratings

Maximum ratings are the extreme limits to which the device can be exposed without permanently damaging it. Do not apply voltages higher than those shown in the table below.

#	Rating	Symbol	Value	Unit	
1	Supply Voltage (continuous) (BUSIN,BUSOUT, HCAP)	$V_{CC}$	-0.3 to +30.0	V	(3)
2	Supply Voltage (pulsed < 400 ms, repetition rate 60s) (BUSIN,BUSOUT, HCAP)	$V_{CC}$	-0.3 to +34.0	V	(3)
3	$C_{REG}$ , $C_{REGA}$ , PCM, TEST1, TEST2, TEST3, TEST4, TEST5, TEST6, TEST7		-0.3 to +3.0	V	(3)
4	BUSIN,BUSOUT, BUSRTN and $H_{CAP}$ Current				
5	Maximum duration 1s	$I_{IN}$	400	mA	(3)
5	Continuous	$I_{IN}$	75	mA	(3)
6	Powered Shock (six sides, 0.5 ms duration)	$g_{pms}$	±2000	g	(5)
7	Unpowered Shock (six sides, 0.5 ms duration)	$g_{shock}$	±2000	g	(5)
8	Drop Shock (to concrete, tile or steel surface, 10 drops, any orientation)	$h_{DROP}$	1.2	m	(5)
9	Electrostatic Discharge (per AEC100)				
9	HBM (100 pF, 1.5 kΩ)	$V_{ESD}$	±2000	V	(5)
10	CDM (R = 0Ω)	$V_{ESD}$	±500	V	(5)
11	MM (200 pF, 0Ω)	$V_{ESD}$	±200	V	(5)
12	Temperature Range				
12	Storage	$T_{stg}$	-40 to +125	°C	(3)
13	Junction	$T_J$	-40 to +150	°C	(3)
14	Thermal Resistance	$\theta_{JC}$	2.5	°C/W	(11)

### 2.2 Operating Range

The operating ratings are the limits normally expected in the application.

$V_L \leq (V_{CC} - V_{SS}) \leq V_H$ ,  $T_L \leq T_A \leq T_H$ ,  $\Delta T \leq 25$  K/min, unless otherwise specified.

#	Characteristic	Symbol	Min	Typ	Max	Units	
15	Supply Voltage		$V_L$	—	$V_H$	V	(1,12)
16	$V_{HCAP}$	$V_{HCAP}$	6.3	—	30	V	(1,12)
16	BUSIN	$V_{BUS}$	-0.3	—	30	V	(1,12)
17	Programming Voltage Applied to BUSIN (DSI)	$V_{PP}$	14.0	—	30.0	V	(3)
18	Programming Current BUSIN	$I_{PP}$	85	—	—	mA	(3)
19	Operating Temperature Range		$T_L$	—	$T_H$	°C	(1)
20		$T_A$	-40	—	+105	°C	(3)
20		$T_A$	-40	—	+125	°C	(3)

## 2.3 Electrical Characteristics - Supply and I/O

$V_L \leq (V_{CC} - V_{SS}) \leq V_H$ ,  $T_L \leq T_A \leq T_H$ ,  $\Delta T \leq 25$  K/min, unless otherwise specified.

#	Characteristic	Symbol	Min	Typ	Max	Units	
21	Quiescent Supply Current *	$I_{DD}$	—	—	8.0	mA	(1)
22	Inrush Current (excluding HCAP Capacitor charge current) Power On until $V_{REG}$ Stable	$I_{INRUSH}$	—	—	20	mA	(3)
23	Internally Regulated Voltages	$V_{REG}$	2.425	2.50	2.575	V	(1)
24		$V_{REGA}$	2.425	2.50	2.575	V	(1)
25	$V_{HCAP}$ Under-Voltage Detection (See Figure 5) Under-Voltage Detection Threshold	$V_{PORHCAP\_f}$	5.8	6.0	6.2	V	(3,6)
26	$V_{HCAP}$ Recovery Threshold	$V_{PORHCAP\_r}$	—	—	6.3	V	(3,6)
27	Hysteresis ( $V_{PORHCAP\_r} - V_{PORHCAP\_f}$ )	$V_{HYST\_HCAP}$	70	100	140	mV	(3)
28	Internal Regulator Low Voltage Detection Threshold $V_{REG}$ Falling $V_{REGA}$ Falling Hysteresis	$V_{PORVREG\_f}$	2.15	2.25	2.40	V	(3,6)
29		$V_{PORVREGA\_f}$	2.15	2.25	2.40	V	(3,6)
30		$V_{HYST\_VREG}$	0.05	0.10	0.15	V	(3)
31		$V_{HYST\_VREGA}$	0.05	0.10	0.15	V	(3)
32	External Capacitor ( $C_{REG}$ , $C_{REGA}$ ) Capacitance	$C_{REG}$ , $C_{REGA}$	500	1000	1500	nF	(9)
33		ESR (including interconnect resistance)	$R_{CREGESR}$ , $R_{CREGAESR}$	—	—	200	m $\Omega$
34	Output High Voltage (PCM) $I_{Load} = 100 \mu A$	$V_{OH}$	$V_{REG} - 0.1$	—	—	V	(9)
35	Output Low Voltage (PCM) $I_{Load} = 100 \mu A$	$V_{OL}$	—	—	0.1	V	(9)

## 2.4 Electrical Characteristics - DSI

$V_L \leq (V_{CC} - V_{SS}) \leq V_H$ ,  $T_L \leq T_A \leq T_H$ ,  $\Delta T \leq 25$  K/min, unless otherwise specified.

#	Characteristic	Symbol	Min	Typ	Max	Units	
36	BUSOUT Bus Switch Resistance $0V \leq V_{BUSIN} \leq 30V$ , $I_{SW} = 160$ mA *	$R_{SW}$	—	4.0	8.0	$\Omega$	(1)
37	HCAP Rectifier Leakage Current $V_{BUSIN} = 0V$ , $V_{HCAP} = 9.0V$ *	$I_{RLKG}$	—	—	100	$\mu A$	(1)
38	BUSIN to HCAP Rectifier Voltage Drop ( $V_{BUSIN} = 7V$ ) $I_{HCAP} = -15$ mA *	$V_{RECT}$	—	0.75	1.0	V	(1)
39		$I_{HCAP} = -100$ mA *	$V_{RECT}$	—	0.9	1.2	V
40	BUSIN Bias Current $V_{BUSIN} = 8.0V$ , $V_{HCAP} = 9.0V$ *	$I_{BUSIN\_BIAS}$	0	—	100	$\mu A$	(1)
41		$V_{BUSIN} = 4.5V$ , $V_{HCAP} = 24V$ , No Response Current	$I_{BUSIN\_BIAS}$	0	—	100	$\mu A$
42	BUSOUT Bias Current $V_{BUSOUT} = 8.0V$ , $V_{HCAP} = 9.0V$ *	$I_{BUSOUT\_BIAS}$	0	—	100	$\mu A$	(1)
43		$V_{BUSOUT} = 4.5V$ , $V_{HCAP} = 24V$ , No Response Current	$I_{BUSOUT\_BIAS}$	0	—	100	$\mu A$
44	BUSOUT Discharge Resistance	$R_{BUSOUT\_Discharge}$	3500	—	8000	$\Omega$	(3)
45	BUSIN Response Current $V_{BUSIN} = 4.0V$ *	$I_{RESP}$	9.9	11	12.1	mA	(1)
46	BUSIN to BUSOUT Leakage Current (BUS SWITCH open) $V_{BUSIN} = 24.0V$ , $V_{BUSOUT} = 0V$ *	$I_{SW\_Leak}$	-20	—	20	$\mu A$	(1)
47		$V_{BUSIN} = 0V$ , $V_{BUSOUT} = 16V$	$I_{RSW\_Leak}$	-20	—	20	$\mu A$
48	BUSIN Logic Thresholds Signal Threshold *	$V_{THS}$	2.8	3.0	3.2	V	(1)
49		Frame Threshold *	$V_{THF}$	5.5	6.0	6.5	V
50	BUSIN Logic Hysteresis Signal *	$V_{HYSS}$	30	—	90	mV	(3)
51		Frame *	$V_{HYSF}$	100	—	300	mV

## 2.5 Electrical Characteristics - Signal Chain

$V_L \leq (V_{CC} - V_{SS}) \leq V_H$ ,  $T_L \leq T_A \leq T_H$ ,  $\Delta T \leq 25$  K/min, unless otherwise specified.

#	Characteristic	Symbol	Min	Typ	Max	Units	
52	Sensitivity (10-bit @ 100Hz referenced to 0 Hz) 50g Range	* SENS	—	10.24	—	LSB/g	(1,14)
53	62.5g Range	* SENS	—	8.192	—	LSB/g	(1,14)
54	125g Range	* SENS	—	4.096	—	LSB/g	(1,14)
55	187g Range	* SENS	—	2.731	—	LSB/g	(1,14)
56	312g Range	* SENS	—	1.638	—	LSB/g	(1,14)
	Total Sensitivity Error (including non-linearity)						
57	$T_A = 25^\circ\text{C}$	* $\Delta\text{SENS}_{25}$	-5	—	+5	%	(1)
58	$T_L \leq T_A \leq T_H$	* $\Delta\text{SENS}$	-7	—	+7	%	(1)
59	Digital Offset 10-bit output	* $\text{OFF}_{10\text{Bit}}$	460	512	564	LSB	(1)
60	Range of Output (10-Bit Mode) Acceleration	$\text{RANGE}_{\text{ACC}}$	1	—	1023	LSB	(3)
61	Internal Error	$\text{RANGE}_{\text{ERR}}$	—	0	—	LSB	(3)
62	Cross-Axis Sensitivity X-axis to Z-axis	$V_{XZ}$	-5	—	+5	%	(3)
63	Y-axis to Z-axis	$V_{YZ}$	-5	—	+5	%	(3)
64	ADC Output Noise Peak (1 Hz - 1 kHz, 10-Bit)	$\eta_{\text{SD}}$	-4	—	+4	LSB	(3)
65	System Output Noise (10-Bit, RMS, All Ranges)	$\eta_{\text{RMS}}$	—	—	+1.2	LSB	(3)
66	Non-linearity (all ranges)	$\text{NL}_{\text{OUT}}$	-2	—	+2	%	(3)

## 2.6 Electrical Characteristics - Self-Test and Overload

$V_L \leq (V_{CC} - V_{SS}) \leq V_H$ ,  $T_L \leq T_A \leq T_H$ ,  $\Delta T \leq 25$  K/min, unless otherwise specified.

#	Characteristic	Symbol	Min	Typ	Max	Units		
67	Acceleration (without hitting internal g-cell stops) ±50g, ±62.5g, ±125g Positive	$g_{g-cell\_Clip60ZP}$	425	642	980	g	(9)	
68		$g_{g-cell\_Clip60ZN}$	-1205	-720	-512	g	(9)	
69	Acceleration (without hitting internal g-cell stops) ±187g, ±312g Positive	$g_{g-cell\_Clip240ZP}$	1450	2180	2800	g	(9)	
70		$g_{g-cell\_Clip240ZN}$	-3100	-2210	-1800	g	(9)	
71	$\Sigma\Delta$ and Sinc Filter Clipping Limit ±50g Range Positive	$g_{ADC\_Clip60ZP}$	160	238	335	g	(9)	
72		$g_{ADC\_Clip60ZN}$	-333	-274	-216	g	(9)	
73	$\Sigma\Delta$ and Sinc Filter Clipping Limit ±62.5g Range Positive	$g_{ADC\_Clip60ZP}$	160	238	335	g	(9)	
74		$g_{ADC\_Clip60ZN}$	-333	-274	-216	g	(9)	
75	$\Sigma\Delta$ and Sinc Filter Clipping Limit ±125g Range Positive	$g_{ADC\_Clip120ZP}$	306	433	577	g	(9)	
76		$g_{ADC\_Clip120ZN}$	-693	-544	-415	g	(9)	
77	$\Sigma\Delta$ and Sinc Filter Clipping Limit ±187g Range Positive	$g_{ADC\_Clip240ZP}$	836	1178	1599	g	(9)	
78		$g_{ADC\_Clip240ZN}$	-1909	-1566	-1245	g	(9)	
79	$\Sigma\Delta$ and Sinc Filter Clipping Limit ±312g Range Positive	$g_{ADC\_Clip480ZP}$	836	1178	1599	g	(9)	
80		$g_{ADC\_Clip480ZN}$	-1909	-1566	-1245	g	(9)	
81	Deflection, 10-Bit, Self-Test - Offset, 30 sample ave, $T_A = 25^\circ\text{C}$ ) ±50g Range *	$\Delta\text{DFLCT\_Z50}$	—	307	—	LSB	(1)	
82		±62.5g Range *	$\Delta\text{DFLCT\_Z62}$	—	245	—	LSB	(1)
83		±125g Range *	$\Delta\text{DFLCT\_Z125}$	—	299	—	LSB	(1)
84		±187g Range *	$\Delta\text{DFLCT\_Z187}$	—	205	—	LSB	(1)
85		±312g Range *	$\Delta\text{DFLCT\_Z312}$	—	123	—	LSB	(1)
86	Self-Test deflection range, $T_A = 25^\circ\text{C}$	$\Delta\text{DFLCT}$	-10	—	+10	%	(1)	
87	Self-Test deflection range, $T_L \leq T_A \leq T_H$	$\Delta\text{DFLCT}$	-20	—	+20	%	(1)	

## 2.7 Dynamic Electrical Characteristics - DSI

$V_L \leq (V_{CC} - V_{SS}) \leq V_H$ ,  $T_L \leq T_A \leq T_H$ ,  $\Delta T \leq 25$  K/min, unless otherwise specified

#	Characteristic	Symbol	Min	Typ	Max	Units	
88	Reset Recovery (See Figure 20) POR negated to 1st DSI Command (Initialization Command)	$t_{DSI\_INIT}$	—	$400 / f_{OSC}$	—	s	(7)
89	POR negated to Acceleration Data Valid (Including LPF Init)	$t_{DSP\_INIT}$	—	—	$10000 / f_{OSC}$	s	(7)
90	DSI Clear Command to 1st DSI Command (Initialization Command)	$t_{DSI\_INIT}$	—	$400 / f_{OSC}$	—	s	(7)
91	DSI Clear Command to Acceleration Data Valid (Including LPF Init)	$t_{DSP\_INIT}$	—	—	$10000 / f_{OSC}$	s	(7)
92	HCAP Under-Voltage Reset Delay (See Figure 5) $V_{HCAP} < V_{PORHCAP\_f}$ to POR assertion	$t_{HCAP\_POR}$	—	$880 / f_{OSC}$	—	s	(7)
93	$V_{REG}$ Under-Voltage Reset Delay (See Figure 6) $V_{REG} < V_{PORVREG\_f}$ to POR assertion	$t_{VREG\_POR}$	—	—	5	$\mu$ s	(3)
94	$V_{REGA}$ Under-Voltage Reset Delay (See Figure 7) $V_{REGA} < V_{PORVREGA\_f}$ to POR assertion	$t_{VREGA\_POR}$	—	—	5	$\mu$ s	(3)
95	$V_{REG}$ , $V_{REGA}$ Capacitor Monitor POR to first Capacitor Test Disconnect	$t_{POR\_CAPTEST}$	—	$12000 / f_{OSC}$	—	s	(7)
96	Disconnect Time ( )	$t_{CAPTEST\_TIME}$	—	6 / $f_{OSC}$	—	s	(7)
97	Disconnect Rate ( )	$t_{CAPTEST\_RATE}$	—	$256 / f_{OSC}$	—	s	(7)
98	Initialization to Bus Switch Closing	$t_{BS}$	89	—	138	$\mu$ s	(7)
99	BUSOUT Discharge Resistance Activation Time	$t_{BUSOUT\_Discharge}$	9.5	10	10.5	$\mu$ s	(3)
100	Communication Data Rate	$D_{RATE}$	100	—	200	kbps	(7)
101	Loss of Signal Reset Time Maximum time below frame threshold	$t_{TO}$	2.00	—	4.00	ms	(7)
102	BUSIN Response Current Slew Rate 1.0 mA to 9.0 mA, 9.0 to 1.0 mA	$t_{ITR}$	0.33	—	10.0	$\text{mA}/\mu\text{s}$	(3)
103	BUSIN Timing to Response Current BUSIN Negative Voltage Transition = 3.0V to $I_{RSP} = 7.0$ mA rise	$t_{RSP\_R}$	—	—	2.50	$\mu$ s	(7)
104	BUSIN Negative Voltage Transition = 3.0V to $I_{RSP} = 5.0$ mA fall	$t_{RSP\_F}$	—	—	2.50	$\mu$ s	(7)
105	DSI BUSIN Signal Duty Cycle Logic '0'	$D_{CL}$	10	33	40	%	(7)
106	Logic '1'	$D_{CH}$	60	67	90	%	(7)
107	Inter-frame Separation Time (See Figure 8) Following Read Write NVM Command	$t_{IFS}$	12	—	—	ms	(7)
108	Following Initialization, BS = 1	$t_{IFS}$	200	—	—	$\mu$ s	(7)
109	Following Initialization, BS = 0	$t_{IFS}$	20	—	—	$\mu$ s	(7)
110	Following other DSI bus commands	$t_{IFS}$	20	—	—	$\mu$ s	(7)
111	DSI Data Latency	$t_{LAT\_DSI}$	$4 / f_{OSC}$	—	$5 / f_{OSC}$	s	(7)
112	Bus Switch Open Time Reset Asserted to $I_{SW\_LEAK} \leq 20 \mu\text{A}$	$t_{BSOPEN}$	—	—	500	$\mu$ s	(3)
113	Self-Test Response Time Self-Test Activation time (EOF <sub>Slave</sub> to 90% $\Delta$ DFLCT_xxx, 180 Hz LPF)	$t_{ST\_ACT\_180}$	2.00	—	5.00	ms	(7)
114	Self-Test Deactivation time (EOF <sub>Slave</sub> to 10% $\Delta$ DFLCT_xxx, 180 Hz LPF)	$t_{ST\_DEACT\_180}$	2.00	—	5.00	ms	(7)
115	Self-Test Activation time (EOF <sub>Slave</sub> to 90% $\Delta$ DFLCT_xxx, 400 Hz LPF)	$t_{ST\_ACT\_400}$	1.00	—	2.50	ms	(7)
116	Self-Test Deactivation time (EOF <sub>Slave</sub> to 10% $\Delta$ DFLCT_xxx, 400 Hz LPF)	$t_{ST\_DEACT\_400}$	1.00	—	2.50	ms	(7)
117	Self-Test Activation time (EOF <sub>Slave</sub> to 90% $\Delta$ DFLCT_xxx, 800 Hz LPF)	$t_{ST\_ACT\_800}$	0.50	—	1.75	ms	(7)
118	Self-Test Deactivation time (EOF <sub>Slave</sub> to 10% $\Delta$ DFLCT_xxx, 800 Hz LPF)	$t_{ST\_DEACT\_800}$	0.50	—	1.75	ms	(7)
119	Error Detection Response Time Mirror Register CRC Error to Status Flag (S) set (Factory or User Array)	$t_{CRC\_Err}$	—	$75 / f_{OSC}$	—	s	(7)

## 2.8 Dynamic Electrical Characteristics - Signal Chain

$V_L \leq (V_{CC} - V_{SS}) \leq V_H$ ,  $T_L \leq T_A \leq T_H$ ,  $\Delta T \leq 25$  K/min, unless otherwise specified

#	Characteristic	Symbol	Min	Typ	Max	Units	
120	Internal Oscillator Frequency *	$f_{OSC}$	3.80	4	4.20	MHz	(1)
121	Data Interpolation Latency	$t_{LAT\_INTERP}$	$64 / f_{OSC}$	—	$65 / f_{OSC}$	s	(7)
122	DSP Low-Pass Filter						
	Cutoff frequency LPF0 (referenced to 0 Hz)	$f_{C\_LPF0}$	171	180	189	Hz	(7)
123	Filter Order LPF0	$O_{LPF0}$	—	2	—	1	(7)
124	Cutoff frequency LPF1 (referenced to 0 Hz)	$f_{C\_LPF1}$	380	400	420	Hz	(7)
125	Filter Order LPF1	$O_{LPF1}$	—	4	—	1	(7)
126	Cutoff frequency LPF2 (referenced to 0 Hz)	$f_{C\_LPF2}$	760	800	840	Hz	(7)
127	Filter Order LPF2	$O_{LPF2}$	—	4	—	1	(7)
128	Sensing Element Rolloff Frequency (-3 db)	$f_{gcell\_3dB\_zlo}$	798	—	2211	Hz	(9)
129	$\pm 50g, \pm 62.5g, \pm 125g$ $\pm 187g, \pm 312g$	$f_{gcell\_3dB\_zhi}$	1437	—	2425	Hz	(9)
130	Sensing Element Natural Frequency						
	$\pm 50g, \pm 62.5g, \pm 125g$	$f_{gcell\_zlo}$	7000	—	8000	Hz	(9)
131	$\pm 187g, \pm 312g$	$f_{gcell\_zhi}$	13600	—	15100	Hz	(9)
132	Sensing Element Damping Ratio						
	$\pm 50g, \pm 62.5g, \pm 125g$	$\zeta_{gcell\_zlo}$	1.870	—	4.610	—	(9)
133	$\pm 187g, \pm 312g$	$\zeta_{gcell\_zhi}$	2.040	—	7.580	—	(9)
134	Sensing Element Delay (@100 Hz)						
	$\pm 50g, \pm 62.5g, \pm 125g$	$f_{gcell\_delay100\_zlo}$	77	—	200	$\mu s$	(9)
135	$\pm 187g, \pm 312g$	$f_{gcell\_delay100\_zhi}$	47	—	160	$\mu s$	(9)
136	Package Resonance Frequency	$f_{Package}$	100	—	—	kHz	(9)

### Notes:

- Parameters tested 100% at final test at -40°C, 25°C, and 105°C.
- Parameters tested 100% at probe.
- Verified by characterization.
- \* Indicates critical characteristic.
- Verified by qualification testing, not tested in production.
- Parameters verified by pass/fail testing in production.
- Functionality guaranteed by modeling, simulation and/or design verification. Circuit integrity assured through IDDQ and scan testing. Timing is determined by internal system clock frequency.
- Verified by user system level characterization, not tested in production, or at component level.
- Verified by Simulation.
- Measured at final test. Self-Test activation occurs under control of the test program.
- Thermal resistance between the die junction and the exposed pad; cold plate is attached to the exposed pad.
- Maximum voltage characterized. Minimum voltage tested 100% at final test. Maximum voltage tested 100% to 24V at final test.
- N/A.
- Sensitivity, and overload capability specifications will be reduced when 800 Hz filter is selected.
- Filter cutoff frequencies are directly dependent upon the internal oscillator frequency.
- Target values. Actual values to be determined during device characterization.

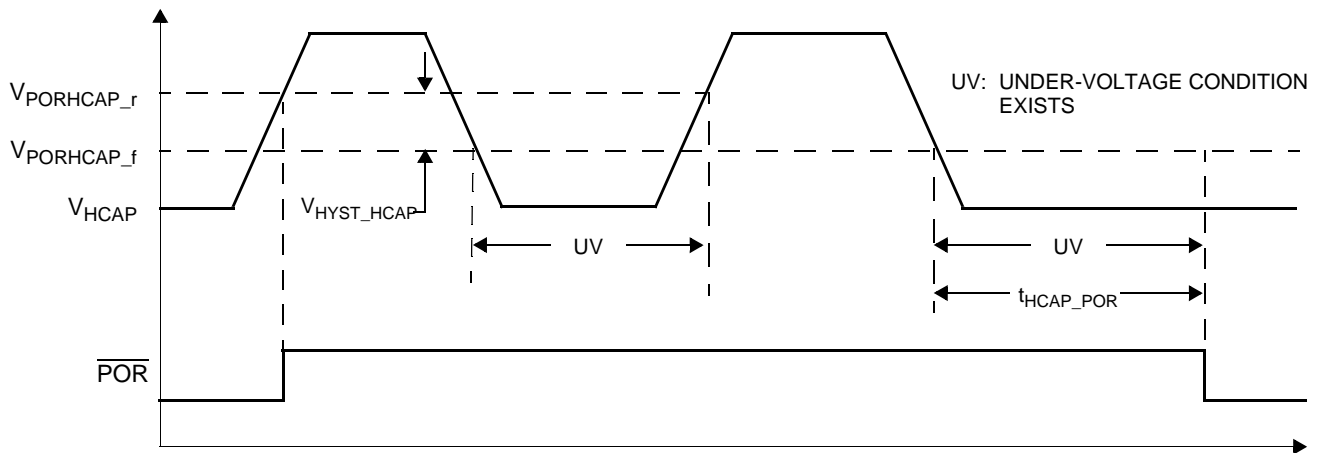

Figure 5.  $V_{HCAP}$  Under-Voltage Detection

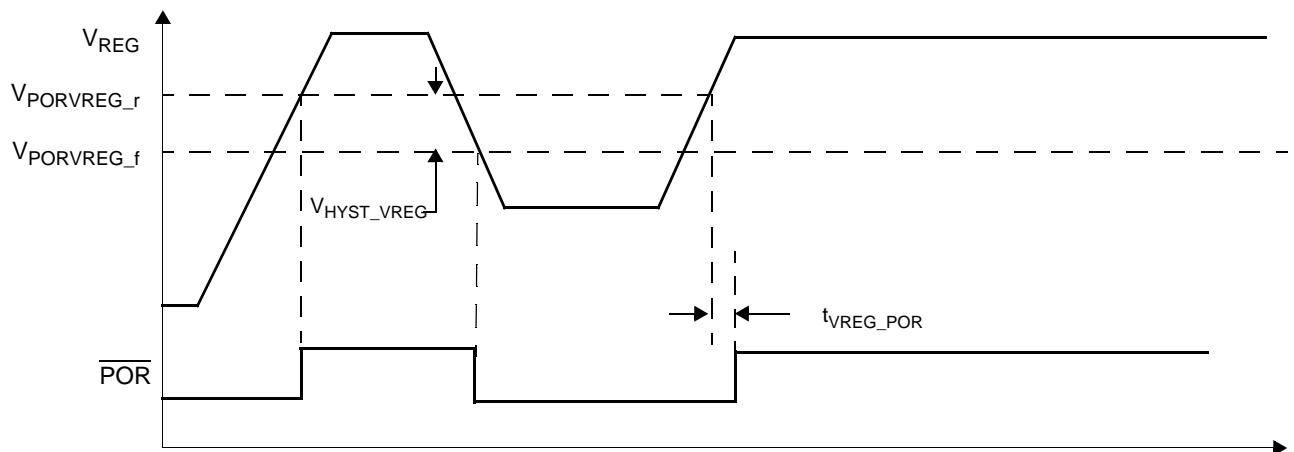

Figure 6.  $V_{REG}$  Under-Voltage Detection

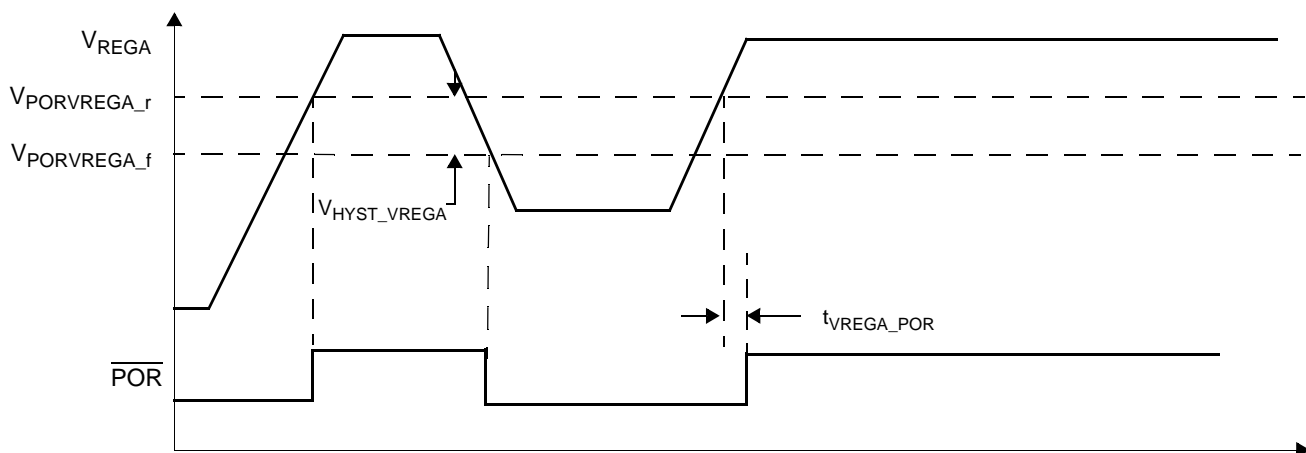

Figure 7.  $V_{REGA}$  Under-Voltage Detection

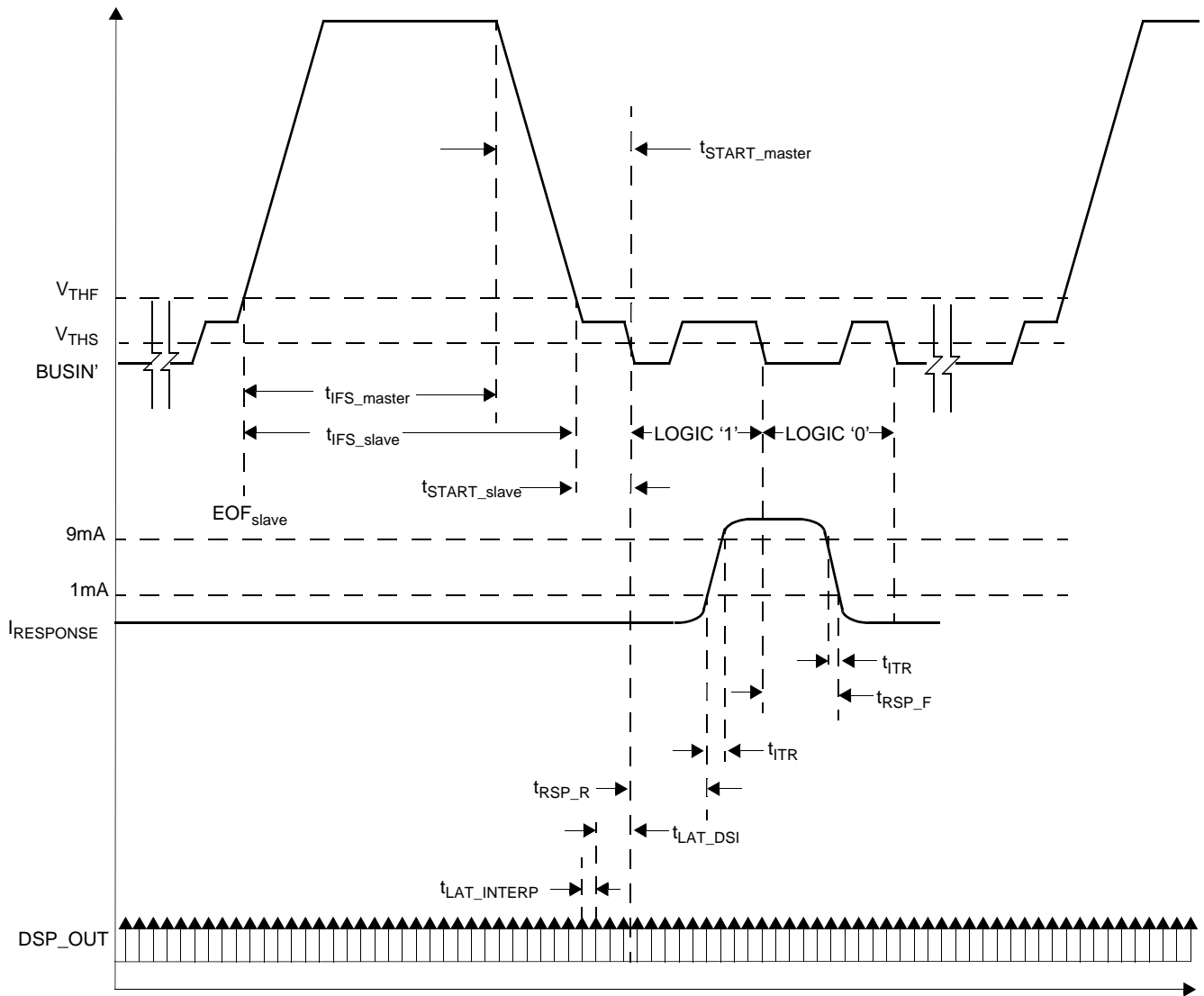

Figure 8. DSI Bus Inter-frame Timing

## 3 Functional Description

### 3.1 User Accessible Data Array

A user accessible data array allows for each device to be customized. The array consists of an OTP factory programmable array, an OTP user programmable array, and read-only registers for device status. The OTP arrays incorporate independent error detection for fault detection (reference [Section 3.2](#)). Portions of the factory programmable array are reserved for factory-programmed trim values. The user accessible data is shown in the table below.

**Table 3. User Accessible Data**

Byte Addr RA[3:0]	Register	Nibble Addr WA[3:0]	Bit Function				Nibble Addr (WA[3:0])	Bit Function				Type	
			7	6	5	4		3	2	1	0		
\$00	SN0		SN[7]	SN[6]	SN[5]	SN[4]		SN[3]	SN[2]	SN[1]	SN[0]	F	
\$01	SN1		SN[15]	SN[14]	SN[13]	SN[12]		SN[11]	SN[10]	SN[9]	SN[8]		
\$02	SN2		SN[23]	SN[22]	SN[21]	SN[20]		SN[19]	SN[18]	SN[17]	SN[16]		
\$03	SN3		SN[31]	SN[30]	SN[29]	SN[28]		SN[27]	SN[26]	SN[25]	SN[24]		
\$04	TYPE	Reference Table 40	LPF[1]	LPF[0]	0	0	Reference Table 40	RNG[3]	RNG[2]	RNG[1]	RNG[0]	U/F	
\$05	DEVCFG		DEVID	0	0	0		0	0	0	0		0
\$06	DEVCFG1		0	0	0	0		0	0	0	AT_OTP[1]		AT_OTP[0]
\$07	DEVCFG2		LOCK_U	0	PCM	0		ADDR[3]	ADDR[2]	ADDR[1]	ADDR[0]		
\$08	UD01		UD01[7]	UD01[6]	UD01[5]	UD01[4]		UD01[3]	UD01[2]	UD01[1]	UD01[0]		
\$09	UD02		UD02[7]	UD02[6]	UD02[5]	UD02[4]		UD02[3]	UD02[2]	UD02[1]	UD02[0]		
\$0A	UD03		UD03[7]	UD03[6]	UD03[5]	UD03[4]		UD03[3]	UD03[2]	UD03[1]	UD03[0]		
\$0B	UD04		UD04[7]	UD04[6]	UD04[5]	UD04[4]		UD04[3]	UD04[2]	UD04[1]	UD04[0]		
\$0C	UD05		UD05[7]	UD05[6]	UD05[5]	UD05[4]		UD05[3]	UD05[2]	UD05[1]	UD05[0]		
\$0D	UD06		UD06[7]	UD06[6]	UD06[5]	UD06[4]		UD06[3]	UD06[2]	UD06[1]	UD06[0]		
\$0E	UD07		UD07[7]	UD07[6]	UD07[5]	UD07[4]		UD07[3]	UD07[2]	UD07[1]	UD07[0]		
\$0F	UD08		UD08[7]	UD08[6]	UD08[5]	UD08[4]		0	0	0	0		

Type codes

F: Freescale programmed OTP location

U/F: User and/or Freescale programmed OTP location.

Note: Unused and Unprogrammed Spare bits always read '0'.

#### 3.1.1 Device Serial Number Registers

A unique serial number is programmed into the serial number registers of each device during manufacturing. The serial number is composed of the following information:

Bit Range	Content
SN[12:0]	Serial Number
SN[31:13]	Lot Number

Serial numbers begin at 1 for all produced devices in each lot, and are sequentially assigned. Lot numbers begin at 1 and are sequentially assigned. No lot will contain more devices than can be uniquely identified by the 13-bit serial number. Depending on lot size and quantities, all possible lot numbers and serial numbers may not be assigned.

The serial number registers are included in the factory programmed OTP CRC verification. Reference [Section 3.2.1](#) for details regarding the CRC verification. Beyond this, the contents of the serial number registers have no impact on device operation or performance, and are only used for traceability purposes.

### 3.1.2 Device Type Register (TYPE)

The Device Type Register is an OTP configuration register which contains device configuration information. Bit 5 - Bit 0 are factory programmed and are included in the factory programmed OTP CRC verification. These bits are read only to the user. Bit 7 - Bit 6 are user programmable OTP bits and are included in the user programmable OTP error detection.

**Table 4. Factory Configuration Register**

Location		Bit									
RA[3:0]	Register	WA[3:0]	7	6	5	4	WA[3:0]	3	2	1	0
\$04	TYPE	Bank0 \$08	LPF[1]	LPF[0]	0	0		RNG[3]	RNG[2]	RNG[1]	RNG[0]
Factory Default			0	0	0	0		0	0	0	0

#### 3.1.2.1 Low-Pass Filter Selection Bits (LPF[1:0]) (TYPE[7:6])

The Low-Pass Filter selection bit selects between one of three low-pass filter options. These bits can be factory or user programmed.

LPF[1]	LPF[0]	Low-Pass Filter Selected
0	0	400 Hz, 4-Pole
0	1	Not Enabled <sup>1</sup>
1	0	180 Hz, 2-Pole
1	1	800 Hz, 4-Pole

<sup>1</sup>This filter option is not implemented. LPF[1:0] must not be set to this value to guarantee proper operation and performance.

#### 3.1.2.2 Range Selection Bits (RNG[3:0]) (TYPE[3:0])

The Range Selection Bits indicate the full-scale range of the device, as shown below. These bits are factory programmed.

RNG[3]	RNG[2]	RNG[1]	RNG[0]	Full-Scale Range	g-Cell Design
0	0	0	0	N/A	N/A
0	0	0	1	N/A	N/A
0	0	1	0	50g	Medium-g
0	0	1	1	62g	Medium-g
0	1	0	0	125g	Medium-g
0	1	0	1	187g	High-g
0	1	1	0	312g	High-g
0	1	1	1	N/A	N/A
1	0	0	0	Reserved	N/A
1	0	0	1		
1	0	1	0		
1	0	1	1		
1	1	0	0		
1	1	0	1		
1	1	1	0		
1	1	1	1		

### 3.1.3 Device Configuration Register (DEVCFG)

The Device configuration register is a user programmable OTP register which contains device configuration information. This register is included in the user register error detection. Refer to [Section 3.2.2](#) for details regarding user programmable OTP array error detection.

**Table 5. Device Configuration Register**

Location		Bit									
RA[3:0]	Register	WA[3:0]	7	6	5	4	WA[3:0]	3	2	1	0
\$05	DEVCFG	Bank0 \$0A	DEVID	0	0	0	Bank0 \$09	0	0	0	0
Factory Default			1	0	0	0		0	0	0	0

#### 3.1.3.1 Device ID Bit (DEVCFG[7])

The Device ID Bit is a user programmable bit which allows the user to select between 2 device IDs. The Device ID is transmitted in response to the Request ID DSI command. Reference [Section 4.2.1.5](#) for more information regarding the Request ID DSI command. This bit can be factory or user programmed.

DEVID	Device ID
0	'00110'
1	'00100'

### 3.1.4 Device Configuration Register 1 (DEVCFG1)

The Device configuration register is a user programmable OTP register which contains device configuration information. This register is included in the user register error detection. Refer to [Section 3.2.2](#) for details regarding the user programmable OTP array error detection.

**Table 6. Device Configuration Register 1**

Location		Bit									
RA[3:0]	Register	WA[3:0]	7	6	5	4	WA[3:0]	3	2	1	0
\$06	DEVCFG1	Bank2 \$06	0	0	0	0	Bank1 \$06	0	0	AT_OTP[1]	AT_OTP[0]
Factory Default			0	0	0	0		0	0	0	0

#### 3.1.4.1 Attribute Bits (AT\_OTP[1:0], DEVCFG1[1:0])

The Attribute Bits are user defined bits which are transmitted in response to the Request Status, Disable Self-Test Stimulus or Enable Self-Test Stimulus DSI commands. The transmitted values are qualified by the LOCK\_U bit as shown in the table below. These bits can be factory or user programmed.

LOCK_U	DEVCFG1 Values		DSI Transmitted Values	
	AT_OTP[1]	AT_OTP[0]	AT[1]	AT[0]
0	X	X	1	0
1	0	0	0	0
	0	1	0	1
	1	0	1	0
	1	1	1	1

### 3.1.5 Device Configuration Register 2 (DEVCFG2)

Device configuration register 2 is a user programmable OTP register which contains device configuration information. This register is included in the user register error detection. Refer to [Section 3.2.2](#) for details regarding the user programmable OTP array error detection.

**Table 7. Device Configuration Register 2**

Location		Bit									
RA[3:0]	Register	WA[3:0]	7	6	5	4	WA[3:0]	3	2	1	0
\$07	DEVCFG2	Bnk0 \$07 Bnk2 \$07 Bnk3 \$07 Bnk3 \$0F	LOCK_U	0	PCM	0	Bnk1 \$07	ADDR[3]	ADDR[2]	ADDR[1]	ADDR[0]
Factory Default			0	0	0	0		0	0	0	0

#### 3.1.5.1 User Configuration Lock Bit (LOCK\_U, DEVCFG2[7])

The LOCK\_U bit is a factory or user programmed OTP bit which inhibits writes to the user configuration array when active. Reference [Section 3.2.2](#) for details regarding the LOCK\_U bit and error detection.

#### 3.1.5.2 PCM Bit (DEVCFG2[5])

The PCM Bit enables the PCM output pin. When the PCM bit is set, the PCM output pin is active and outputs a Pulse Code Modulated signal proportional to the acceleration response. Reference [Section 3.5.3.6](#) for more information regarding the PCM output. When the PCM output is cleared, the PCM output pin is actively pulled low. This bit can be factory or user programmed.

#### 3.1.5.3 Device Address (ADDR[3:0], DEVCFG2[3:0])

The Device Address bits define the preprogrammed DSI Bus device address. If the Device Address bits are programmed to '0000', there is not preprogrammed address, and the address must be assigned via the Initialization DSI command. Reference [Section 4.2.1.1](#) for more details regarding the Initialization DSI command. These bits can be factory or user programmed.

### 3.1.6 User Data Registers (UDx)

The User Data Registers are user programmable OTP register which can be programmed with user or assembly specific information. These registers have no impact on the device performance, but are included in the user register error detection. Refer to [Section 3.2.2](#) for details regarding the user register error detection.

Location		Bit									
RA[3:0]	Register	WA[3:0]	7	6	5	4	WA[3:0]	3	2	1	0
\$08	UD01	Bnk2 \$08	UD01[7]	UD01[6]	UD01[5]	UD01[4]	Bnk1 \$08	UD01[3]	UD01[2]	UD01[1]	UD01[0]
\$09	UD02	Bnk2 \$09	UD02[7]	UD02[6]	UD02[5]	UD02[4]	Bnk1 \$09	UD02[3]	UD02[2]	UD02[1]	UD02[0]
\$0A	UD03	Bnk2 \$0A	UD03[7]	UD03[6]	UD03[5]	UD03[4]	Bnk1 \$0A	UD03[3]	UD03[2]	UD03[1]	UD03[0]
\$0B	UD04	Bnk2 \$0B	UD04[7]	UD04[6]	UD04[5]	UD04[4]	Bnk1 \$0B	UD04[3]	UD04[2]	UD04[1]	UD04[0]
\$0C	UD05	Bnk2 \$0C	UD05[7]	UD05[6]	UD05[5]	UD05[4]	Bnk1 \$0C	UD05[3]	UD05[2]	UD05[1]	UD05[0]
\$0D	UD06	Bnk2 \$0D	UD06[7]	UD06[6]	UD06[5]	UD06[4]	Bnk1 \$0D	UD06[3]	UD06[2]	UD06[1]	UD06[0]
\$0E	UD07	Bnk2 \$0E	UD07[7]	UD07[6]	UD07[5]	UD07[4]	Bnk1 \$0E	UD07[3]	UD07[2]	UD07[1]	UD07[0]
\$0F	UD08	Bnk2 \$0F	UD08[7]	UD08[6]	UD08[5]	UD08[4]		0	0	0	0
Factory Default			0	0	0	0		0	0	0	0

## 3.2 OTP Array Lock and Error Detection

### 3.2.1 Factory Programmed OTP Array Lock and Error Detection

The Factory programmed OTP array is verified for errors with a 3-bit CRC. The CRC verification is enabled only when the Factory programmed OTP array is locked and the lock is active. The lock is active only after an automatic OTP readout in which the internal lock bit is read as '1'. Automatic OTP readouts occur only after POR or a DSI Clear Command is received.

Factory Lock Bit Value in Fuse Array	Lock Bit Value in Mirror Register After Automatic Readout	Lock Bit Active?	CRC Verification Enabled?
0	N/A	NO	NO
1	0	NO	NO
1	1	YES	YES

The Factory programmed OTP array is locked by Freescale and will always be active after POR. The CRC is continuously calculated on the factory programmed OTP array, which includes the registers listed below:

Register Name	Register Addresses	Included in Factory CRC?
Serial Number Registers	SN0, SN1, SN2, SN3	Yes
Type Register	TYPE[5:0]	Yes
Factory Programmable Device Configuration Bits	Internal Register Map	Yes
Factory OTP Array CRC	CRC_F[2:0]	No
Factory OTP Array Lock Bit	LOCK_F	No

Bits are fed in from right to left (LSB first), and top to bottom (lower addresses first) in the register map. The CRC verification uses a generator polynomial of  $g(x) = X^3 + X + 1$ , with a seed value = '111'. The calculated CRC is compared against the CRC\_F[2:0] bits. If a CRC mismatch is detected, an internal data error is set and the device responds to DSI messages as specified in Section 4.3. The CRC verification is completed on the memory registers which hold a copy of the fuse array values, not the fuse array values.

### 3.2.2 User Programmable OTP Array Lock and Error Detection

The user programmable OTP array is independently verified for errors. The error detection is enabled only when the user programmable OTP array is locked as shown below.

Factory Lock Bit Value in Fuse Array	Lock Bit Value in Mirror Register After Automatic Readout	Lock Bit Active?	CRC Verification Enabled?
0	N/A	NO	NO
1	0	NO	NO
1	1	YES	YES

When the LOCK\_U bit is set, the error detection code is calculated on the user programmable OTP Array registers listed below and stored to NVM.

Register Name	Register Addresses
Type Register	TYPE[7:6]
Device ID Bit	DEVCFG[7]: DEVID
Attribute Bits	DEVCFG1[1:0]: AT_OTP[1:0]
PCM Bit	DEVCFG2[5]: PCM
Device Address	DEVCFG2[3:0]: ADDR[3:0]
User Data Registers 1 - 8	UD01 - UD08

During normal operation, the error detection code is continuously compared against the stored error detection code. If a mismatch is detected, an internal data error is set, and the device responds to DSI messages as specified in Section 4.3. The error detection code is calculated on the memory registers which hold a copy of the fuse array values, not the fuse array values.

Writes to the User Programmable OTP array using the Write NVM Command will update the mirror registers and result in a change to the error detection code regardless of the state of the LOCK\_U bit. An error detection mismatch will only be detected if the LOCK\_U bit is active.

### 3.3 Voltage Regulators

The device derives its internal supply voltage from the HCAP supply voltage. The device includes separate internal voltage regulators for the analog ( $V_{REGA}$ ) and digital circuitry ( $V_{REG}$ ). External filter capacitors are required, as shown in Figure 1.

The voltage regulator module includes voltage monitoring circuitry which holds the device in reset following power-on until the HCAP and internal voltages have stabilized sufficiently for proper operation. The voltage monitor asserts internal reset when the HCAP supply or internally regulated voltages fall below predetermined levels. A reference generator provides a stable voltage which is used by the  $\Sigma\Delta$  converter.

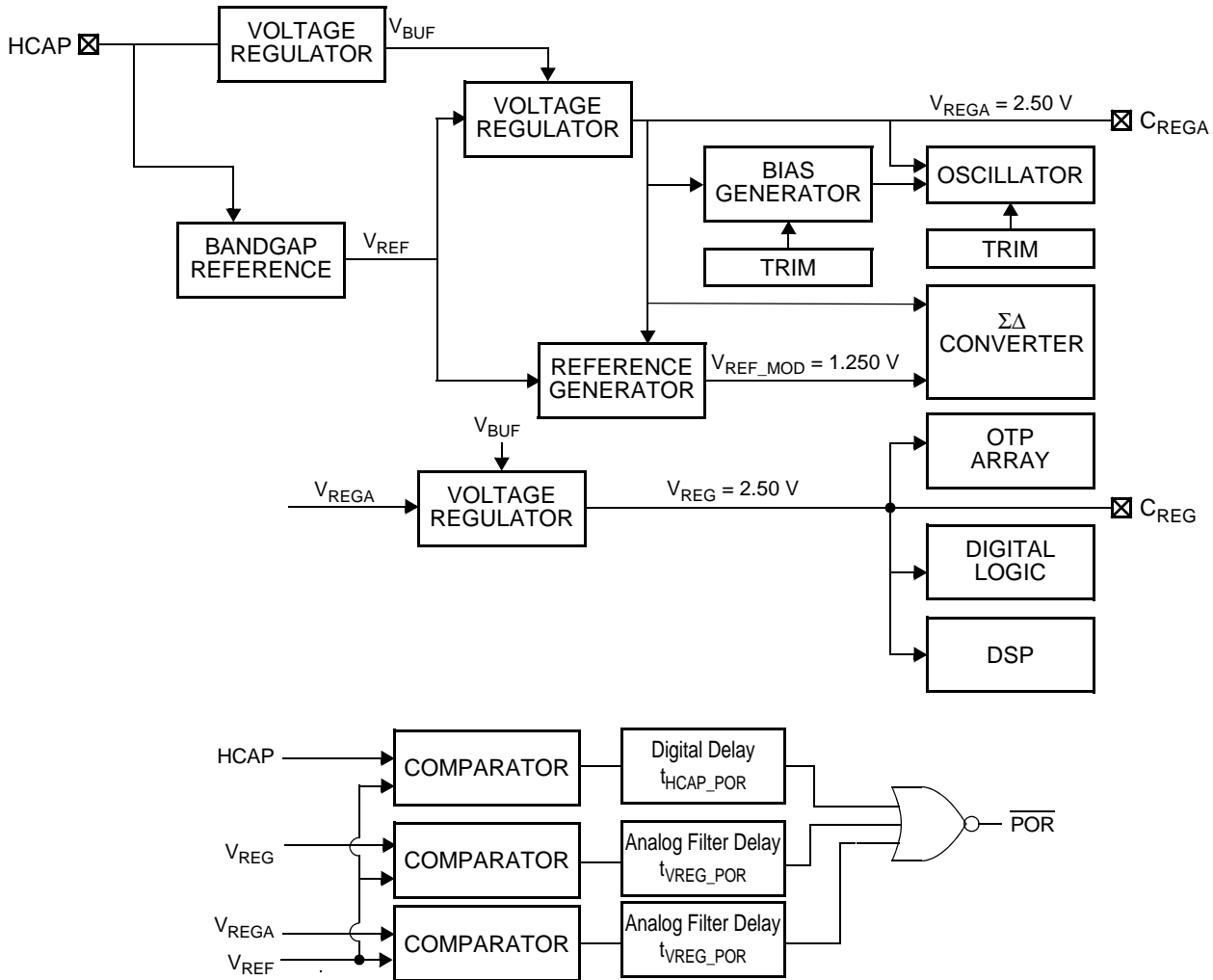

Figure 9. Voltage Regulation and Monitoring

#### 3.3.1 $C_{REG}$ and $C_{REGA}$ Regulator Capacitor

The internal regulator requires an external capacitor between the  $C_{REG}$  pin and  $V_{SS}$  pin, and the  $C_{REGA}$  pin and  $V_{SSA}$  pin for stability. Figure 1 shows the recommended types and values for each of these capacitors.

#### 3.3.2 $V_{HCAP}$ Voltage Monitor

The device includes a circuit to monitor the voltage on the HCAP pin. If the voltage falls below the specified threshold in Section 2, the device will be reset within the reset delay time ( $t_{HCAP\_POR}$ ) specified in Section 2.7.

### 3.3.3 $V_{REG}$ and $V_{REGA}$ Under-Voltage Monitor

The device includes a circuit to monitor the internally regulated voltages ( $V_{REG}$  and  $V_{REGA}$ ). If either of the internal regulator voltages fall below the specified thresholds in Section 2, the device will be reset within the reset delay time ( $t_{VREG\_POR}$ ,  $t_{VREGA\_POR}$ ) specified in Section 2.7.

### 3.3.4 $V_{REG}$ and $V_{REGA}$ Capacitance Monitor

A monitor circuit is incorporated to ensure predictable operation if the connection to the external  $C_{REG}$  or  $C_{REGA}$  capacitor becomes open. At a continuous rate specified in Section 2.7 ( $t_{CAPTEST\_RATE}$ ), both regulators are simultaneously disabled for a short duration ( $t_{CAPTEST\_TIME}$ ). If either of the external capacitors are not present, the associated regulator voltage will fall below the internal reset threshold, forcing a device reset.

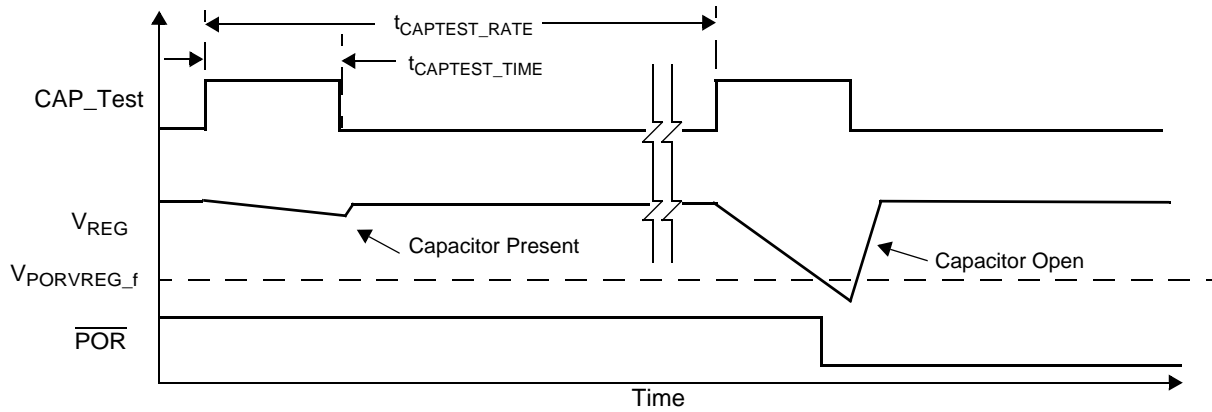

Figure 10.  $V_{REG}$  Capacitor Monitor

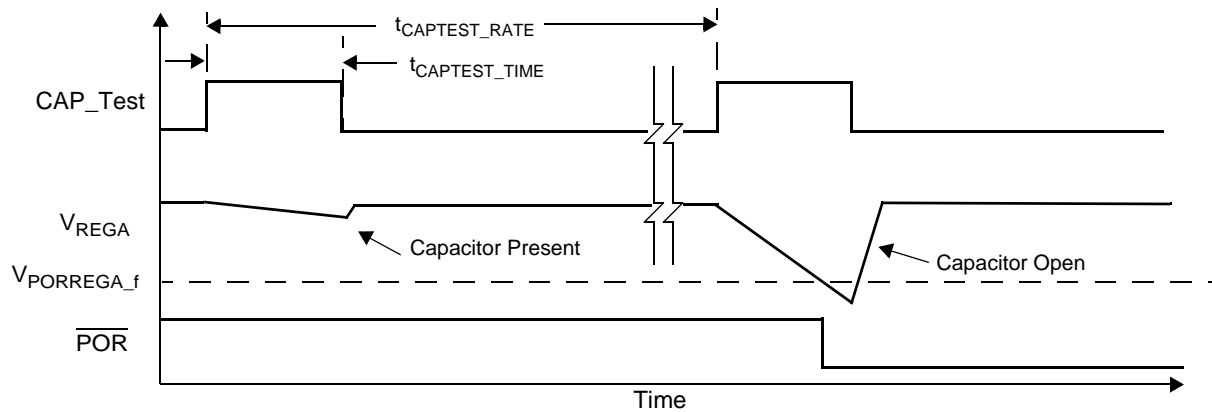

Figure 11.  $V_{REGA}$  Capacitor Monitor

## 3.4 Internal Oscillator

The device includes a factory trimmed oscillator as specified in Section 2.8.

### 3.5 Acceleration Signal Path

#### 3.5.1 Transducer

The device transducer is an overdamped mass-spring-damper system described by the following transfer function:

$$H(s) = \frac{\omega_n^2}{s^2 + 2 \cdot \xi \cdot \omega_n \cdot s + \omega_n^2}$$

where:

$\zeta$  = Damping Ratio

$\omega_n$  = Natural Frequency =  $2 \cdot \pi \cdot f_n$

Reference [Section 2.8](#) for transducer parameters.

#### 3.5.2 $\Sigma\Delta$ Converter

The sigma delta converter provides the interface between the g-cell and the DSP block. The output of the  $\Sigma\Delta$  converter is a data stream at a nominal frequency of 1 MHz.

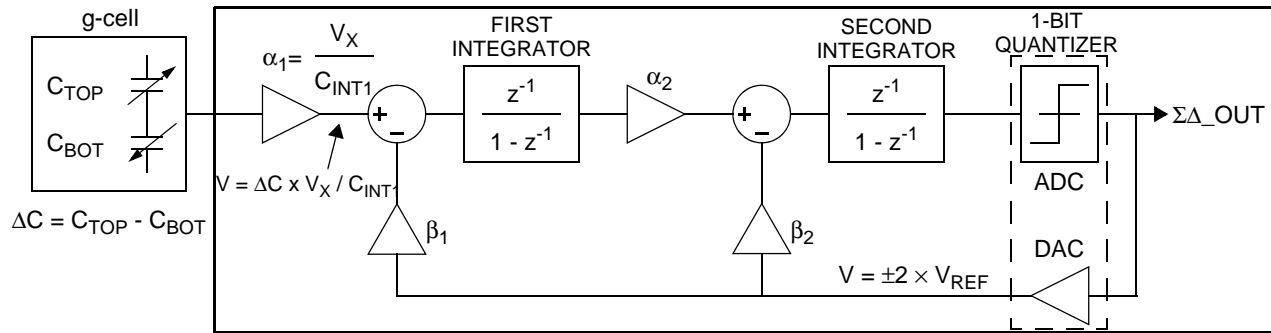

Figure 12.  $\Sigma\Delta$  Converter Block Diagram

#### 3.5.3 Digital Signal Processing Block

A digital signal processing (DSP) block is used to perform signal filtering and compensation operations. A diagram illustrating the signal processing flow within the DSP block is shown in [Figure 13](#).

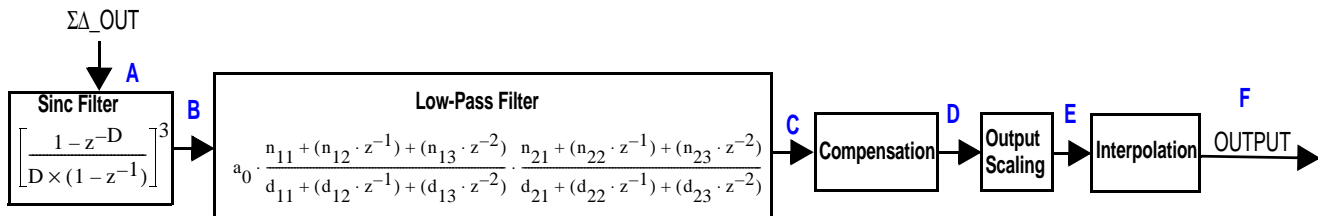

Figure 13. Signal Chain Diagram

**Table 8. Signal Chain Characteristics**

	Description	Sample Time (μs)	Data Width (Bits)	Over Range (Bits)	Signal Width (Bits)	Signal Noise (Bits)	Signal Margin (Bits)	Typical Block Latency	Reference
A	ΣΔ	1	1		1			112/f <sub>osc</sub>	Section 3.5.2
B	SINC Filter	16	20		12	4			Section 3.5.3.1
C	Low-Pass Filter	16	26	1	12	4	9	Reference Section 3.5.3.2	Section 3.5.3.2
D	Compensation	16	26	4	10	3	9	24/f <sub>osc</sub>	Section 3.5.3.3
E	DSP Sampling	16			10			4/f <sub>osc</sub>	Section 3.5.3.5
	10-Bit Output Scaling								
F	Interpolation	1			10			64/f <sub>osc</sub>	Section 3.5.3.5

**3.5.3.1 Decimation Sinc Filter**

The serial data stream produced by the ΣΔ converters is decimated and converted to parallel values by a 3rd order 16:1 sinc filter with a decimation factor of 16.

$$H(z) = \left[ \frac{1 - z^{-16}}{16 \times (1 - z^{-1})} \right]^3$$

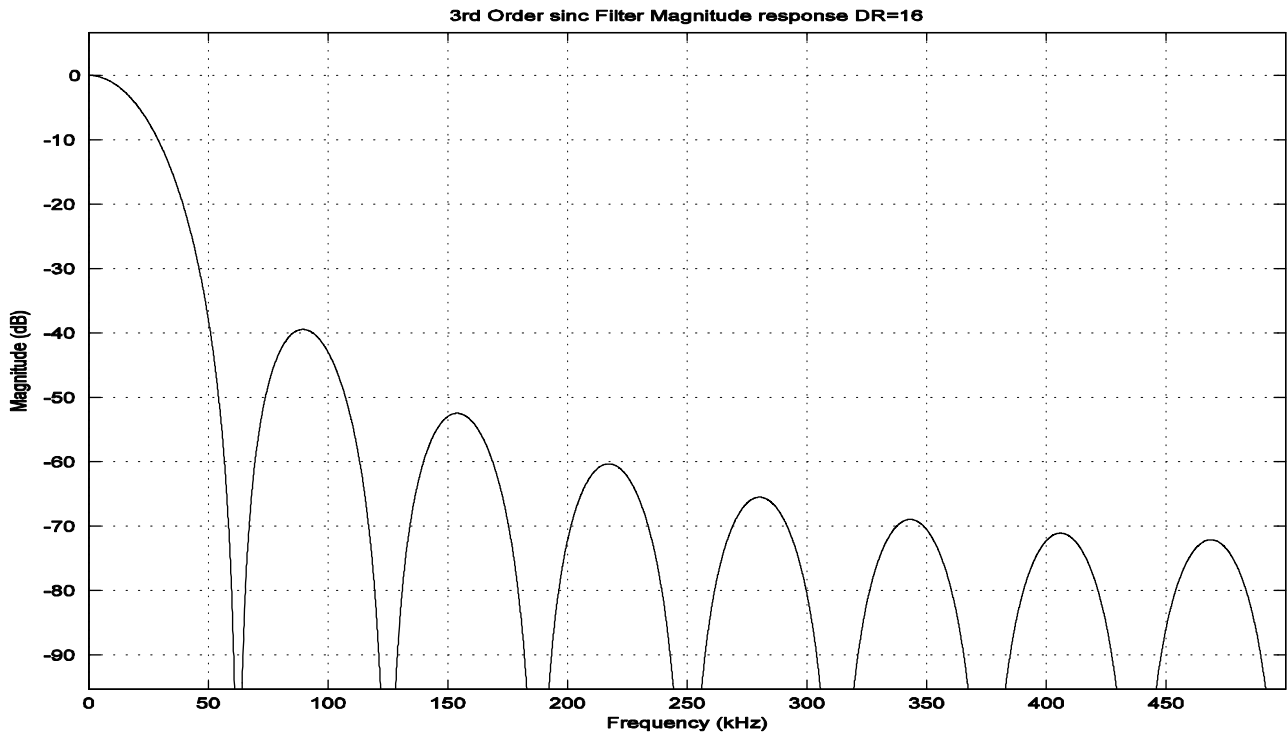

**Figure 14. Sinc Filter Response, t<sub>S</sub> = 16 μs**

### 3.5.3.2 Low-Pass Filter

Data from the Sinc filter is processed by an infinite impulse response (IIR) low-pass filter.

$$H(z) = a_0 \cdot \frac{(n_{11} \cdot z^0) + (n_{12} \cdot z^{-1}) + (n_{13} \cdot z^{-2})}{(d_{11} \cdot z^0) + (d_{12} \cdot z^{-1}) + (d_{13} \cdot z^{-2})} \cdot \frac{(n_{21} \cdot z^0) + (n_{22} \cdot z^{-1}) + (n_{23} \cdot z^{-2})}{(d_{11} \cdot z^0) + (d_{22} \cdot z^{-1}) + (d_{23} \cdot z^{-2})}$$

The device provides the option for one of three low-pass filters. The filter is selected with the LPF[1:0] bits in the TYPE register. The filter selection options are listed in [Section 3.1.2.1, Table 9](#). Response parameters for the low-pass filter are specified in [Section 2.8](#). Filter characteristics are illustrated in the figures below.

**Table 9. Low-Pass Filter Coefficients**

Description	Filter Coefficients				Group Delay
180 Hz LPF	a <sub>0</sub>	0.000534069200512			4608/f <sub>osc</sub>
	n <sub>11</sub>	0.25	d <sub>11</sub>	1	
	n <sub>12</sub>	0.499999985098839	d <sub>12</sub>	-1.959839582443237	
	n <sub>13</sub>	0.25	d <sub>13</sub>	0.960373640060425	
	n <sub>21</sub>	1	d <sub>21</sub>	1	
	n <sub>22</sub>	0	d <sub>22</sub>	0	
	n <sub>23</sub>	0	d <sub>23</sub>	0	
400 Hz LPF	a <sub>0</sub>	0.003135988372378			3392/f <sub>osc</sub>
	n <sub>11</sub>	0.000999420881271	d <sub>11</sub>	1.0	
	n <sub>12</sub>	0.001998946070671	d <sub>12</sub>	-1.892452478408814	
	n <sub>13</sub>	0.000999405980110	d <sub>13</sub>	0.89558845758438	
	n <sub>21</sub>	0.250004753470421	d <sub>21</sub>	1.0	
	n <sub>22</sub>	0.499986037611961	d <sub>22</sub>	-1.919075012207031	
	n <sub>23</sub>	0.250009194016457	d <sub>23</sub>	0.923072755336761	
800 Hz LPF	a <sub>0</sub>	0.011904109735042			1728/f <sub>osc</sub>
	n <sub>11</sub>	0.003841564059258	d <sub>11</sub>	1.0	
	n <sub>12</sub>	0.007683292031288	d <sub>12</sub>	-1.790004611015320	
	n <sub>13</sub>	0.003841534256935	d <sub>13</sub>	0.801908731460571	
	n <sub>21</sub>	0.250001862645149	d <sub>21</sub>	1.0	
	n <sub>22</sub>	0.499994158744812	d <sub>22</sub>	-1.836849451065064	
	n <sub>23</sub>	0.250003993511200	d <sub>23</sub>	0.852215826511383	

Note: Low-Pass Filter Figures do not include g-cell frequency response.

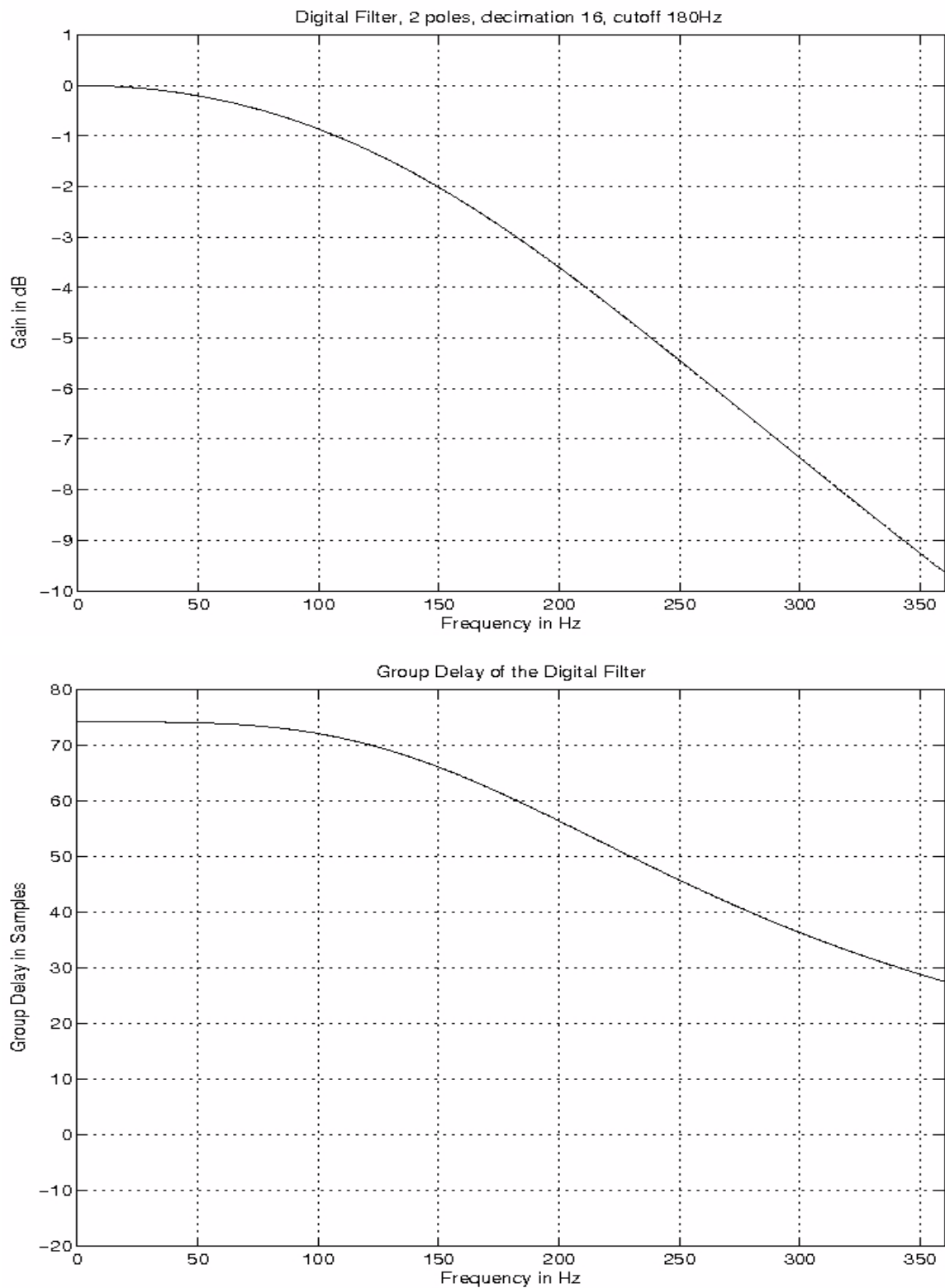

Figure 15. Low-Pass Filter Characteristics:  $f_C = 180$  Hz, 2-Pole,  $t_S = 16 \mu s$

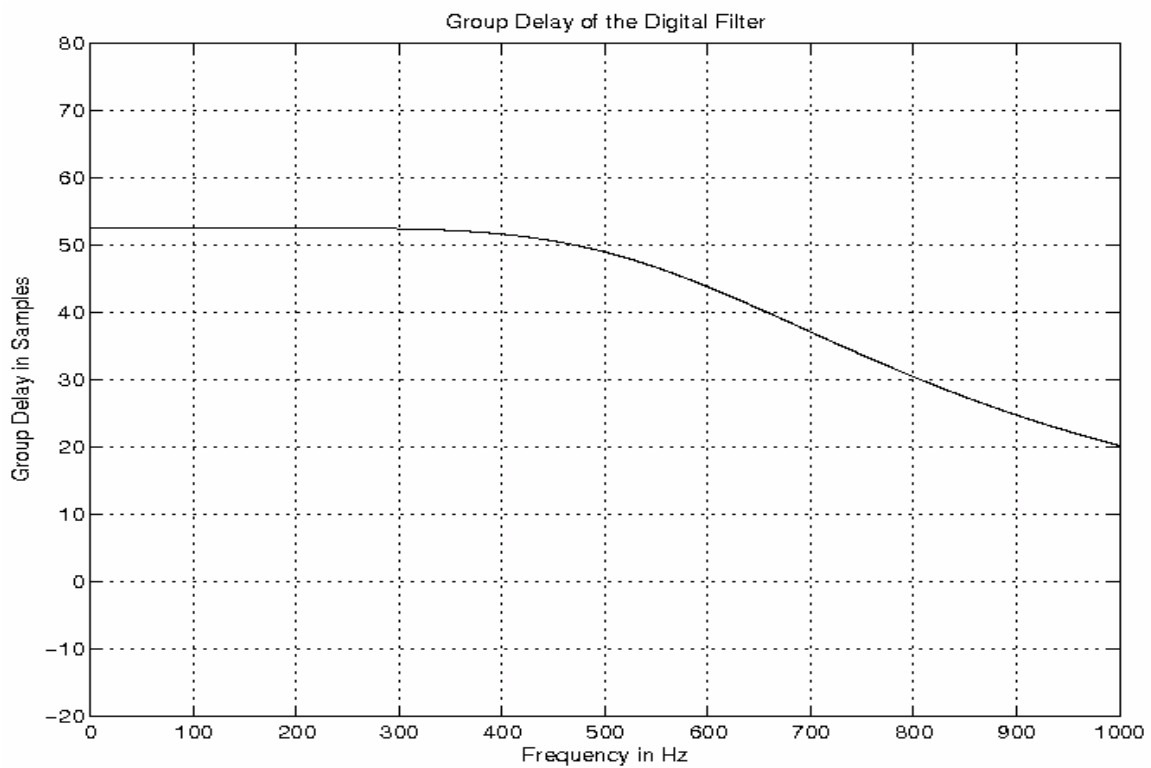
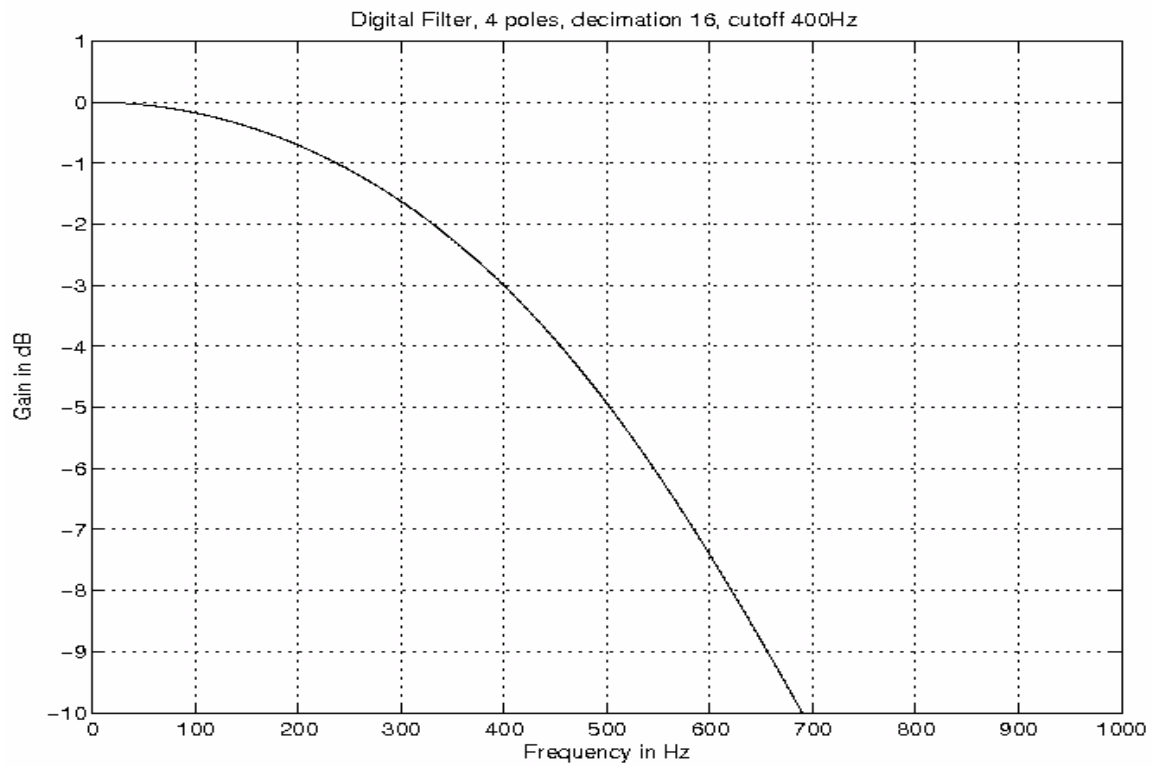

Figure 16. Low-Pass Filter Characteristics:  $f_C = 400$  Hz, 4-Pole,  $t_S = 16 \mu s$

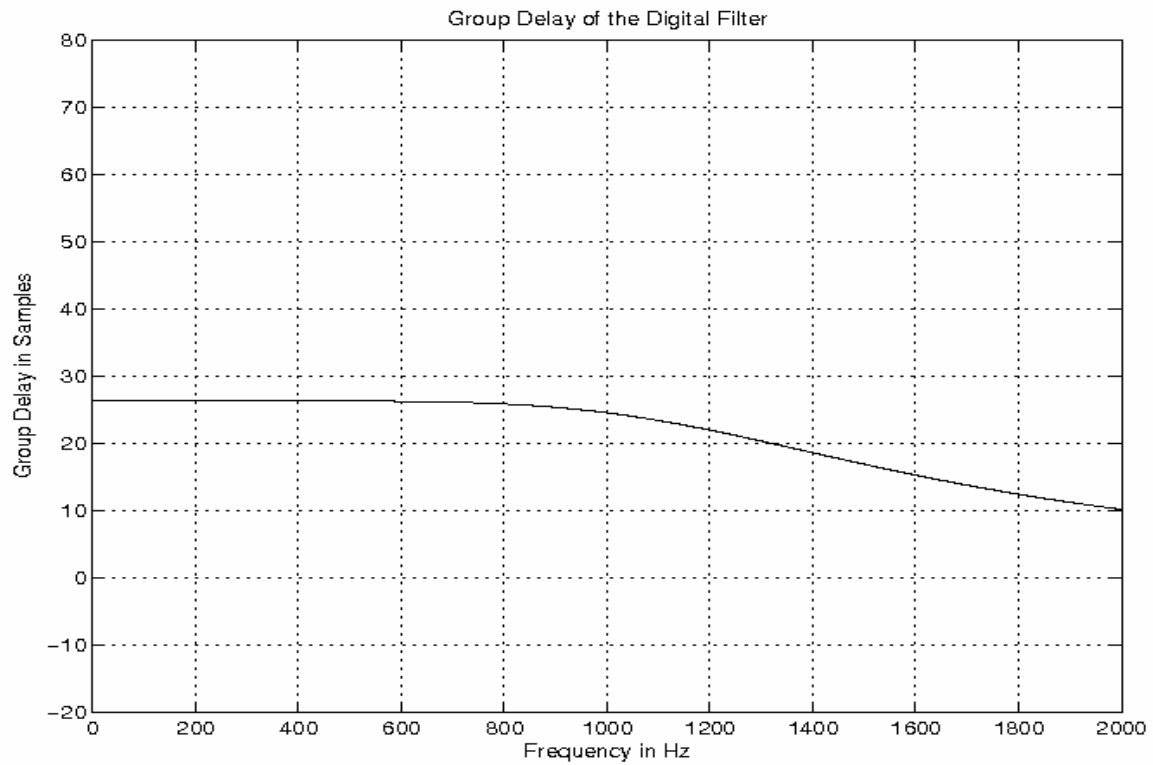
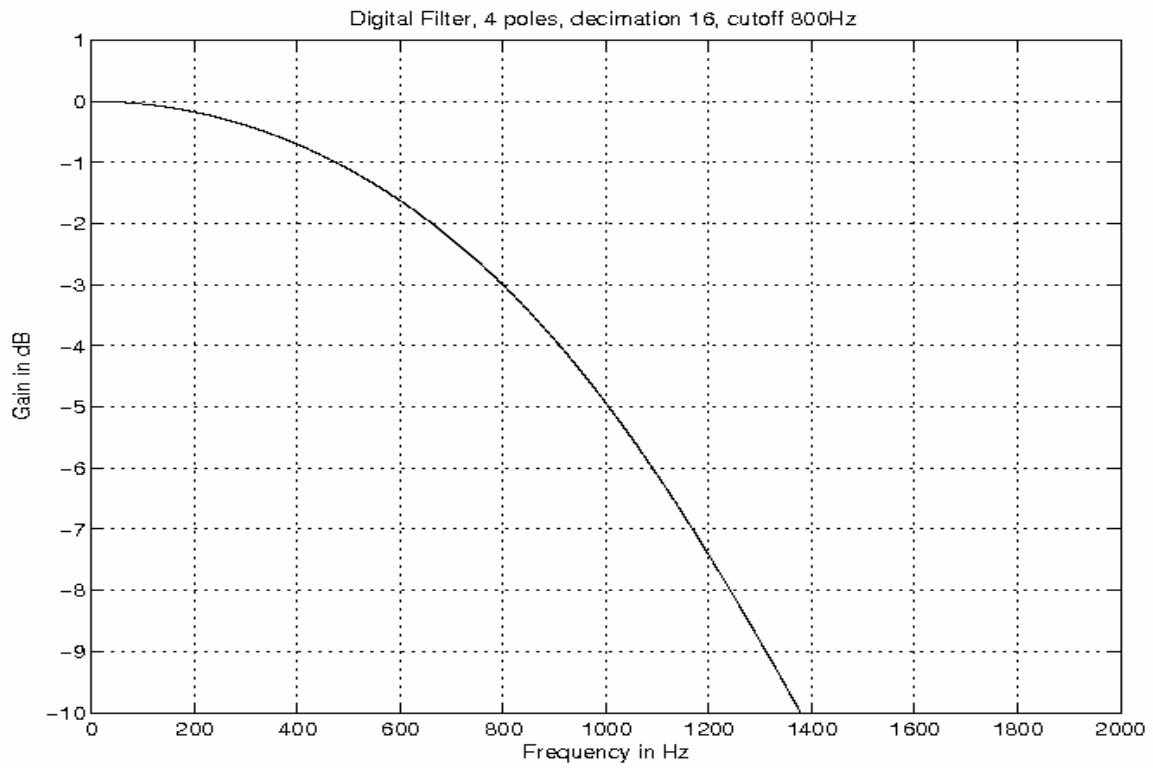

Figure 17. Low-Pass Filter Characteristics:  $f_c = 800$  Hz, 4-Pole,  $t_s = 16 \mu s$

### 3.5.3.3 Compensation

The device includes internal compensation circuitry to compensate for sensor offset, sensitivity and non-linearity.

### 3.5.3.4 Data Interpolation

The device includes 16 to 1 linear data interpolation to minimize the system sample jitter. Each result produced by the digital signal processing chain is delayed one sample time. On reception of an acceleration data request, the transmitted data is interpolated from the two previous samples, resulting in a latency of one sample time, and a maximum signal jitter of  $\pm 1/16$  of a sample time. Reference [Figure 8](#) for more information regarding interpolation and data latency.

### 3.5.3.5 Output Scaling

The 26 bit digital output from the DSP is clipped and scaled to a 10-bit or 8-bit word which covers the acceleration range of the device. [Figure 18](#) shows the method used to establish the acceleration data word from the 26-bit DSP output.

Over Range				Signal										Noise			Margin				
D25	D24	D23	D22	D21	D20	D19	D18	D17	D16	D15	D14	D13	D12	D11	D10	D9	D8	...	D2	D1	D0
10-Bit Data Word				D21	D20	D19	D18	D17	D16	D15	D14	D13	D12	Using Truncation							
9-Bit Data Word				D21	D20	D19	D18	D17	D16	D15	D14	D13	Using Truncation								
8-Bit Data Word				D21	D20	D19	D18	D17	D16	D15	D14	Using Truncation									

Figure 18. Output Scaling Diagram

### 3.5.3.6 PCM Output Function

The device provides the option for a PCM output function. The PCM output is activated if the PCM bit is set in the DEVCFG2 register. When the PCM function is enabled, a 4 MHz Pulse Code Modulated signal proportional to the upper 9 bits of the acceleration response is output onto the PCM pin. The PCM output is intended for test use only. A block diagram of the PCM output is shown in [Figure 19](#).

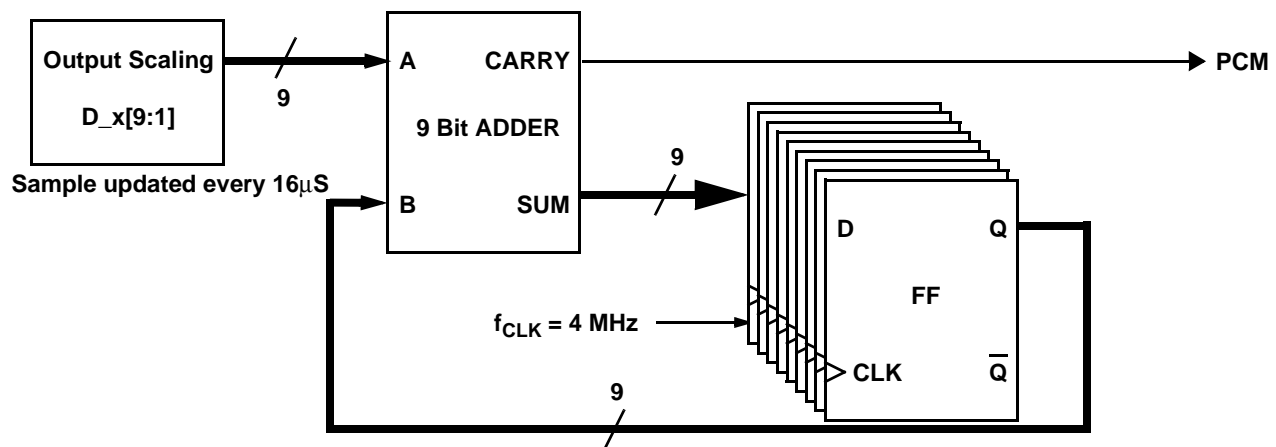

Figure 19. PCM Output Function Block Diagram

### 3.6 Device Initialization

Following powerup, under-voltage reset or reception of a DSI Clear Command, the device proceeds through an initialization process as described in the following tables:

**Table 10. Power-up or Under-Voltage Reset Initialization Process**

#	Description	Time	S Flag	ST Flag	DSI Response
1	Power up to a Known State	0	N/A	N/A	No Response
3	Read Fuse Array and Copy to Memory Array (Mirror Registers)		1	0	No Response
4	Initialize DSI State Machine (the device is ready for DSI Messages)	$t_{DSI\_INIT}$	1	0	DSI Read Acceleration Data Short response = zero. DSI Read Acceleration Data Long response = invalid data.
5	Initialize the DSP (Acceleration Data is Valid)	$t_{DSP\_INIT}$	0	0	Normal

**Table 11. DSI Clear Command Initialization Process**

#	Description	Time	S Flag	ST Flag	DSI Response
1	the device logic comes out of reset	0	1	0	No Response
3	Read Fuse Array and Copy to Memory Array (Mirror Registers)		1	0	No Response
4	Initialize DSI State Machine (the device is ready for DSI Messages)	$t_{DSI\_INIT}$	1	0	DSI Read Acceleration Data Short response = zero. DSI Read Acceleration Data Long response = invalid data.
5	Initialize the DSP (Acceleration Data is Valid)	$t_{DSP\_INIT}$	0	0	Normal

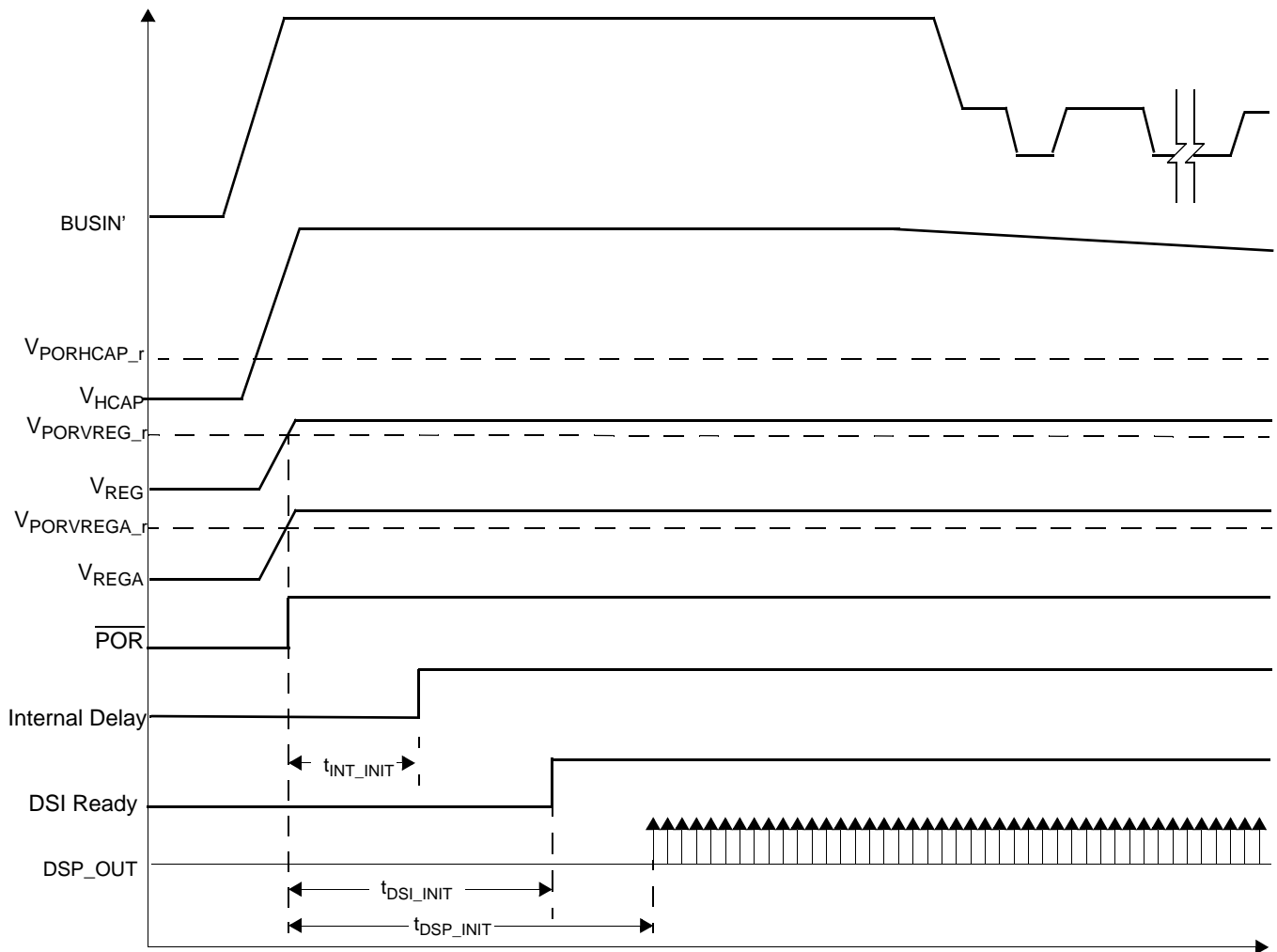

**Figure 20. Initialization Timing**

## 3.7 Overload Response

### 3.7.1 Overload Performance

The device is designed to operate within a specified range. However, acceleration beyond that range (overload) impacts the operating range output of the sensor. Acceleration beyond the range of the device can generate a DC shift at the output of the device that is dependent upon the overload frequency and amplitude. The device g-cell is overdamped, providing the optimal design for overload performance. However, the performance of the device during an overload condition is affected by many other parameters, including:

- g-cell damping
- Non-linearity
- Clipping limits
- Symmetry

Figure 21 shows the g-cell, Sigma Delta, and output clipping of the device over frequency. The relevant parameters are specified in Section 2.

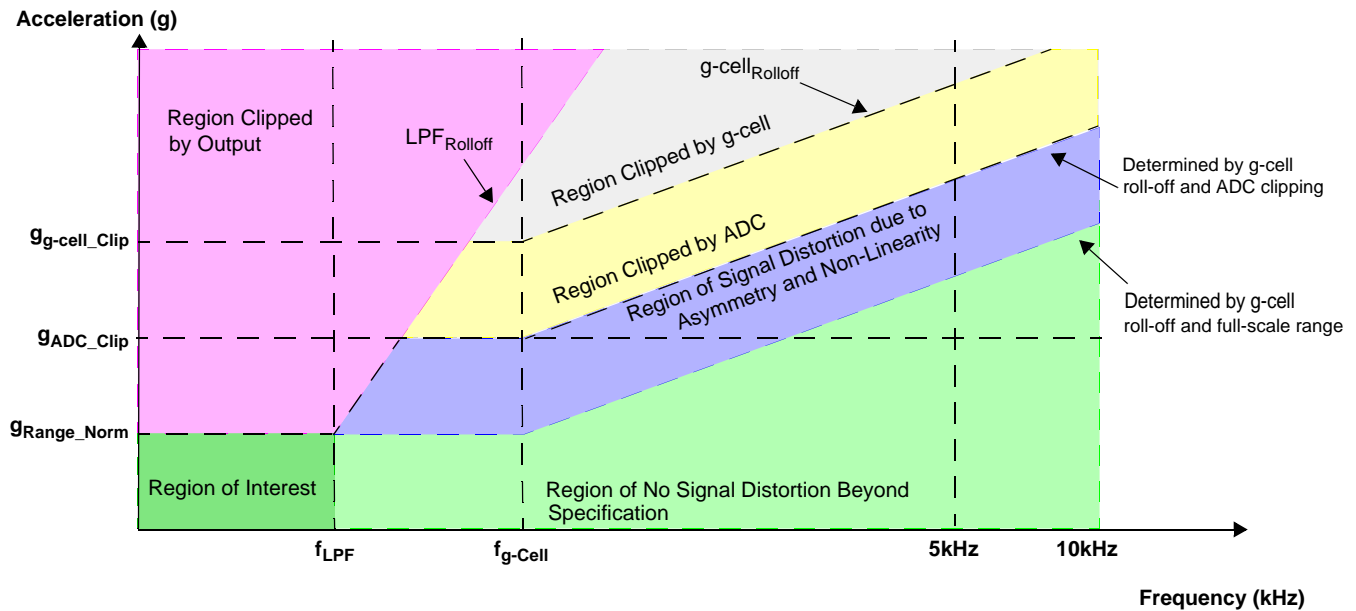

Figure 21. Output Clipping Vs. Frequency

### 3.7.2 Sigma Delta Overrange Response

Ovrage conditions exist when the signal level is beyond the full-scale range of the device but within the computational limits of the DSP. The  $\Sigma\Delta$  converter can saturate at levels above those specified in Section 2 ( $G_{\text{ADC\_CLIP}}$ ). The DSP operates predictably under all cases of overrange, although the signal may include residual high frequency components for some time after returning to the normal range of operation due to non-linear effects of the sensor.

## 4 DSI Protocol Layer

### 4.1 Communication Interface Overview

The device is compatible with the DSI Bus Standard V2.5.

#### 4.1.1 DSI Physical Layer

Reference DSI Bus Standard V2.5, Section 3 for information regarding the physical layer.

#### 4.1.2 DSI Data Link Layer

Reference DSI Bus Standard, V2.5, Section 4 for information regarding the DSI data link layer. The sections below describe the DSI data link layer features supported.

### 4.2 DSI Protocol

#### 4.2.1 DSI Bus Commands

DSI Bus Commands are summarized in [Table 12](#). The device supports only the command formats specified in [Section 4.2.1](#). The device will ignore commands of any other format. If a CRC error is detected, or a reserved or un-implemented command is received, the device will not respond.

Following all messages, the device requires a minimum inter-frame separation ( $t_{IFS}$ ). As long as the minimum inter-frame separation times defined in [Section 4.2.1](#) are met, all supported commands are guaranteed to be executed, and the device will be ready for the next message. The device will respond as appropriate during the subsequent DSI transfer. Exactly one response is attempted.

**Table 12. DSI Bus Command Summary**

Command					Command Format	Data								
C3	C2	C1	C0	Hex	Description		D7	D6	D5	D4	D3	D2	D1	D0
0	0	0	0	\$0	Initialization	Standard Long Only	NV	BS	Bnk[1]	Bnk[0]	PA[3]	PA[2]	PA[1]	PA[0]
0	0	0	1	\$1	Request Status	Standard/Enhanced L/S	—	—	—	—	—	—	—	—
0	0	1	0	\$2	Read Acceleration Data	Standard/Enhanced L/S	—	—	—	—	—	—	—	—
0	0	1	1	\$3	Not Implemented	Not Implemented	Not Implemented							
0	1	0	0	\$4	Request ID Information	Standard/Enhanced L/S	—	—	—	—	—	—	—	—
0	1	0	1	\$5	Not Implemented	Not Implemented	Not Implemented							
0	1	1	0	\$6	Not Implemented	Not Implemented	Not Implemented							
0	1	1	1	\$7	Clear	Standard/Enhanced L/S	—	—	—	—	—	—	—	—
1	0	0	0	\$8	Not Implemented	Not Implemented	Not Implemented							
1	0	0	1	\$9	Read Write NVM	Standard/Enhanced L	WA[3]	WA[2]	WA[1]	WA[0]	RD[3]	RD[2]	RD[1]	RD[0]
1	0	1	0	\$A	Format Control	Standard/Enhanced L	R/W	FA[2]	FA[1]	FA[0]	FD[3]	FD[2]	FD[1]	FD[0]
1	0	1	1	\$B	Read Register Data	Standard/Enhanced L	0	0	0	0	RA[3]	RA[2]	RA[1]	RA[0]
1	1	0	0	\$C	Disable Self-Test	Standard/Enhanced L/S	—	—	—	—	—	—	—	—
1	1	0	1	\$D	Activate Self-Test	Standard/Enhanced L/S	—	—	—	—	—	—	—	—
1	1	1	0	\$E	Not Implemented	Not Implemented	Not Implemented							
1	1	1	1	\$F	Reverse Initialization	Not Implemented	Not Implemented							

### 4.2.1.1 Initialization Command

The initialization command conforms to the description provided in Section 6.1.1 of the DSI Bus Standard V2.5. The initialization command is only supported as a standard long command. No other commands are recognized by the device until a valid standard long initialization command is received.

**Table 13. Initialization Command**

Data								Address				Command				CRC
D[7]	D[6]	D[5]	D[4]	D[3]	D[2]	D[1]	D[0]	A[3]	A[2]	A[1]	A[0]	C[3]	C[2]	C[1]	C[0]	
NV	BS	Bank[1]	Bank[0]	PA[3]	PA[2]	PA[1]	PA[0]	A[3]	A[2]	A[1]	A[0]	0	0	0	0	4 bits

**Table 14. Initialization Command Bit Definitions**

Bit Field	Definition
C[3:0]	Initialization Command = '0000'
A[3:0]	DSI device address. This address is set to the preprogrammed device address following reset, or to '0000' if no preprogrammed address has been assigned.
PA[3:0]	DSI Address to be programmed.
Bank[1:0]	These bits select the bank address for the user writable data registers. Bank selection affects the Read/Write NVM command operation. Invalid combinations of B1 and B0 result in no response from the device to the associated initialization. Refer to <a href="#">Section 4.2.1.10</a> for further details regarding register programming and bank selection.
BS	Bus Switch state. This bit controls the state of the DSI bus switch. 1 - Close the bus switch. 0 - Do not close the bus switch.
NV	NVM Program Enable. This bit enables programming of the user-programmed OTP locations. Data to be programmed is transferred to the device during subsequent Read Write NVM commands. 1 - Enable OTP programming 0 - Disable OTP programming

**Figure 22** illustrates the sequence of operations performed following negation of internal power-on reset (POR) and execution of a DSI Initialization command. The BUSOUT node is tested for a bus short to high voltage condition, and the bus fault (BF) flag is set if an error condition is detected. If no bus fault condition is detected and the BS bit is set in the Initialization command message, the bus switch will be closed. The device implements a blanking time ( $t_{\text{DSI\_BLANK\_INIT}}$ ) to allow for the bus voltage to recover following closure of the bus switch.

If the device has been preprogrammed, PA[3:0] and A[3:0] must match the preprogrammed address.

If no device address has been previously programmed into the OTP array, PA[3:0] contains the device address, and A[3:0] must be zero. If either addressing condition is not met, the device address is not assigned, the bus switch will remain open and the device will not respond to the Initialization command. If the addressing conditions are met, the new device address is assigned to A[3:0]. Once the device address is assigned, the new address (A[3:0]) is not protected by the user programmable OTP array error detection. The user programmable OTP array error detection is calculated and verified using the OTP programmed values of A[3:0] = '0000'.

Once initialized, the device will no longer recognize or respond to Initialization commands.

**Table 15. Initialization Command Response**

Response																CRC
D[15]	D[14]	D[13]	D[12]	D[11]	D[10]	D[9]	D[8]	D[7]	D[6]	D[5]	D[4]	D[3]	D[2]	D[1]	D[0]	
PA[3]	PA[2]	PA[1]	PA[0]	0	0	0	BF	NV	BS	Bank[1]	Bank[0]	PA[3]	PA[2]	PA[1]	PA[0]	4 bits

**Table 16. Initialization Response Bit Definitions**

Bit Field	Definition
PA[3:0]	DSI device address. This field contains the device address. If the device is unprogrammed when the initialization command is issued, the device address is assigned. This field contains the programmed address. An Initialization command which attempts to assign a device address of zero is ignored.
Bank[1:0]	These bits select the bank address for the user writable data registers. Bank selection affects the Read/Write NVM command operation. Invalid combinations of B1 and B0 result in no response from the device to the associated initialization. Refer to <a href="#">Section 4.2.1.10</a> for further details regarding register programming and bank selection.
BS	Bus Switch state. This bit controls the state of the bus switch: 1 - Close the bus switch 0 - Do not close the bus switch
NV	NVM Program Enable. This bit indicates if programming of the user-accessible OTP is enabled. 1 - OTP programming Enabled 0 - OTP programming Disabled
BF	This bit indicates the success or failure of the bus test performed as part of the Initialization command. 1 - Bus fault detected 0 - Bus test passed

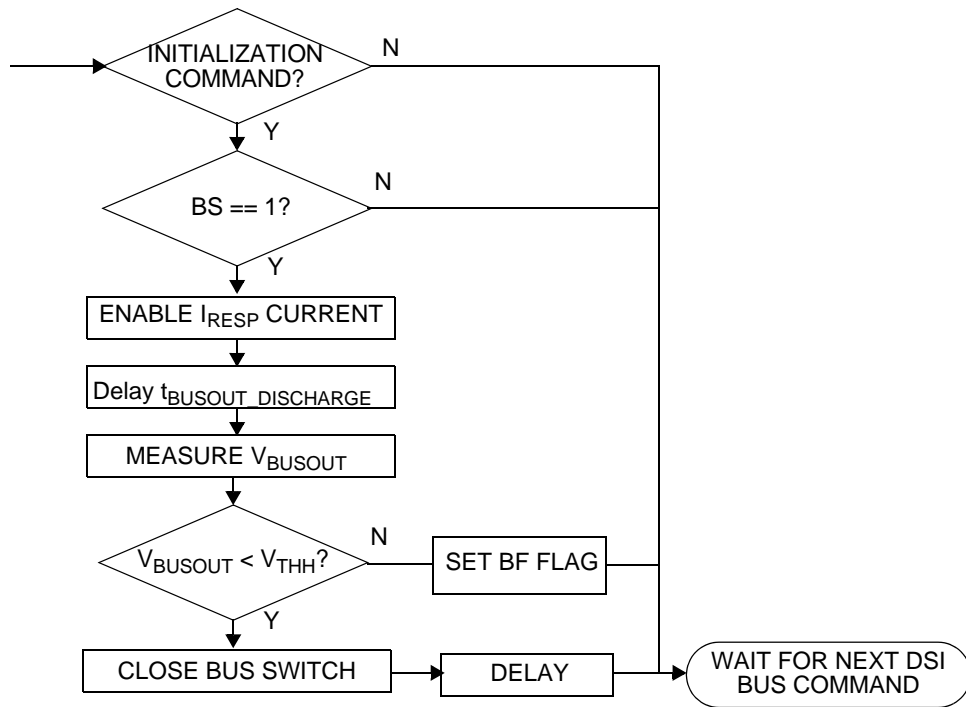

Figure 22. Initialization Sequence

#### 4.2.1.2 Request Status Command

The Request Status command is supported in the following command formats:

- Standard Long Command
- Standard Short Command
- Enhanced Long Command as configured by the Format Control Command (Reference [Section 4.2.1.11](#))
- Enhanced Short Command as configured by the Format Control Command (Reference [Section 4.2.1.11](#))

The device ignores the Request Status command if the DSI device address is set to the DSI Global Device Address of '0000'. The data bits D[7:0] in the command are only used in the CRC calculation.

**Table 17. Request Status Command**

Data								Address				Command				CRC
D[7]	D[6]	D[5]	D[4]	D[3]	D[2]	D[1]	D[0]	A[3]	A[2]	A[1]	A[0]	C[3]	C[2]	C[1]	C[0]	
—	—	—	—	—	—	—	—	A[3]	A[2]	A[1]	A[0]	0	0	0	1	0 to 8 bits

**Table 18. Request Status Command Bit Definitions**

Bit Field	Definition
C[3:0]	Request Status Command = '0001'
A[3:0]	DSI device address. This field contains the device address. This field must match the internal programmed address field. Otherwise, the command is ignored.
D[7:0]	Used for CRC calculation only

**Table 19. Short Response - Request Status Command**

Response															CRC
D[14]	D[13]	D[12]	D[11]	D[10]	D[9]	D[8]	D[7]	D[6]	D[5]	D[4]	D[3]	D[2]	D[1]	D[0]	
0	0	0	0	0	0	0	NV	U	ST	BS	AT[1]	AT[0]	S	0	0 to 8 bits

**Table 20. Long Response - Request Status Command**

Data															CRC	
D[15]	D[14]	D[13]	D[12]	D[11]	D[10]	D[9]	D[8]	D[7]	D[6]	D[5]	D[4]	D[3]	D[2]	D[1]		D[0]
A[3]	A[2]	A[1]	A[0]	0	0	0	0	NV	U	ST	BS	AT[1]	AT[0]	S	0	0 to 8 bits

**Table 21. Request Status Response Bit Definitions**

Bit Field	Definition
S	This bit indicates whether the device has detected an internal device error. 1 - Internal Error detected. 0 - No Internal Error detected Reference <a href="#">Table 60</a> for conditions that set the S bit.
AT[1:0]	Attribute bits located in Register DEVCFG1 (Reference <a href="#">Section 3.1.4.1</a> )
BS	Bus Switch state. This bit controls the state of the bus switch: 1 - Close the bus switch 0 - Do not close the bus switch
ST	This bit indicates whether internal self-test circuitry is active 1 - Self-Test active 0 - Self-Test disabled
U	This bit is set if the voltage at HCAP is below the threshold specified in <a href="#">Section 2</a> . Refer to <a href="#">Section 3.3.2</a> for details.
NV	NVM Program Enable. This bit indicates whether programming of the user-programmable OTP locations is enabled. 1 - OTP programming Enabled 0 - OTP programming Disabled
A[3:0]	DSI device address. This field contains the device address.
	Shaded bits are transmitted to meet the response message length of the received message

### 4.2.1.3 Read Acceleration Data Command

The Read Acceleration Data command is supported in the following command formats:

- Standard Long Command
- Standard Short Command
- Enhanced Long Command as configured by the Format Control Command (Reference [Section 4.2.1.11](#))
- Enhanced Short Command as configured by the Form at Control Command (Reference [Section 4.2.1.11](#))

The device ignores the Request Status command if the DSI device address is set to the DSI Global Device Address of '0000'. The data bits D[7:0] in the command are only used in the CRC calculation.

**Table 22. Read Acceleration Data Command**

Data								Address				Command				CRC
D[7]	D[6]	D[5]	D[4]	D[3]	D[2]	D[1]	D[0]	A[3]	A[2]	A[1]	A[0]	C[3]	C[2]	C[1]	C[0]	
—	—	—	—	—	—	—	—	A[3]	A[2]	A[1]	A[0]	0	0	1	0	0 to 8 bits

**Table 23. Read Acceleration Data Command Bit Definitions**

Bit Field	Definition
C[3:0]	Read Acceleration Data Command = '0010'
A[3:0]	DSI device address. This field contains the device address. This field must match the internal programmed address field. Otherwise, the command is ignored.
D[7:0]	Used for CRC calculation only

**Table 24. Short Response - Read Acceleration Data Command**

Response Length	Response																CRC
	D[14]	D[13]	D[12]	D[11]	D[10]	D[9]	D[8]	D[7]	D[6]	D[5]	D[4]	D[3]	D[2]	D[1]	D[0]		
8								AD[9]	AD[8]	AD[7]	AD[6]	AD[5]	AD[4]	AD[3]	AD[2]		0 to 8 bits
9							AD[9]	AD[8]	AD[7]	AD[6]	AD[5]	AD[4]	AD[3]	AD[2]	AD[1]		
10																	
11																	
12																	
13																	
14																	
15	AT_OTP[1]	AT_OTP[0]	ST	0	S	AD[9]	AD[8]	AD[7]	AD[6]	AD[5]	AD[4]	AD[3]	AD[2]	AD[1]	AD[0]		

**Table 25. Long Response - Read Acceleration Data Command**

Response																CRC
D[15]	D[14]	D[13]	D[12]	D[11]	D[10]	D[9]	D[8]	D[7]	D[6]	D[5]	D[4]	D[3]	D[2]	D[1]	D[0]	
A[3]	A[2]	A[1]	A[0]	0	S	AD[9]	AD[8]	AD[7]	AD[6]	AD[5]	AD[4]	AD[3]	AD[2]	AD[1]	AD[0]	0 to 8 bits

**Table 26. Read Acceleration Response Bit Definitions**

Bit Field	Definition
AD[9:0]	Ten-bit acceleration result produced by the device.
S	This bit indicates whether the device has detected an internal device error. 1 - Internal Error detected. 0 - No Internal Error detected Reference <a href="#">Table 60</a> for conditions that set the S bit.
ST	This bit indicates whether internal self-test circuitry is active 1 - Self-Test active 0 - Self-Test disabled
A[3:0]	DSI device address. This field contains the device address.
AT_OTP[1:0]	Attribute bits located in Register DEVCFG1 (Reference <a href="#">Section 3.1.4.1</a> )
	Shaded bits are transmitted to meet the response message length of the received message

The device truncates the LSBs for Acceleration Data Responses of length less than 10. If the result of the truncation is 0, the minimum acceleration value is transmitted as defined in [Table 27](#).

**Table 27. Acceleration Data Values**

8-Bit Data Value		9-Bit Data Value		10-Bit Data Value		Description
Decimal	Hex	Decimal	Hex	Decimal	Hex	
255	0xFF	511	0x1FF	1023	0x3FF	Maximum positive acceleration value
•	•	•	•	•	•	Positive acceleration values
•	•	•	•	•	•	
•	•	•	•	•	•	
131	0x83	259	0x103	515	0x203	
130	0x82	258	0x102	514	0x202	Typical 0 g level
129	0x81	257	0x101	513	0x201	
128	0x80	256	0x100	512	0x200	
127	0x7F	127	0x0FF	511	0x1FF	Negative acceleration values
126	0x7E	126	0x0FE	510	0x1FE	
125	0x7D	125	0x0FD	509	0x1FD	
•	•	•	•	•	•	Maximum negative acceleration value
•	•	•	•	•	•	
•	•	•	•	•	•	
1	1	1	1	1	1	Maximum negative acceleration value
0	0	0	0	0	0	Sensor Error

**4.2.1.4 DSI Command #3**

DSI Command '0011' is not implemented. The device ignores all command formats with a command ID of '0011'.

#### 4.2.1.5 Request ID Information Command

The Request ID Information command is supported in the following command formats:

- Standard Long Command
- Standard Short Command
- Enhanced Long Command as configured by the Format Control Command (Reference [Section 4.2.1.11](#))
- Enhanced Short Command as configured by the Format Control Command (Reference [Section 4.2.1.11](#))

The device ignores the Request ID Information command if the DSI device address is set to the DSI Global Device Address of '0000'. The data bits D[7:0] in the command are only used in the CRC calculation.

**Table 28. Request ID Information Command**

Data								Address				Command				CRC
D[7]	D[6]	D[5]	D[4]	D[3]	D[2]	D[1]	D[0]	A[3]	A[2]	A[1]	A[0]	C[3]	C[2]	C[1]	C[0]	
—	—	—	—	—	—	—	—	A[3]	A[2]	A[1]	A[0]	0	1	0	0	0 to 8 bits

**Table 29. Request ID Information Command Bit Definitions**

Bit Field	Definition
C[3:0]	Request ID Information Data Command = '0100'
A[3:0]	DSI device address. This field contains the device address. This field must match the internal programmed address field. Otherwise, the command is ignored.
D[7:0]	Used for CRC calculation only

**Table 30. Short Response - Request ID Information Command**

Response															CRC
D[14]	D[13]	D[12]	D[11]	D[10]	D[9]	D[8]	D[7]	D[6]	D[5]	D[4]	D[3]	D[2]	D[1]	D[0]	
0	0	0	0	0	0	0	V2	V1	V0	0	DEVID	1	0	0	0 to 8 bits

**Table 31. Long Response - Request ID Information Command**

Response																CRC
D[15]	D[14]	D[13]	D[12]	D[11]	D[10]	D[9]	D[8]	D[7]	D[6]	D[5]	D[4]	D[3]	D[2]	D[1]	D[0]	
A[3]	A[2]	A[1]	A[0]	0	0	0	0	V[2]	V[1]	V[0]	0	DEVID	1	0	0	0 to 8 bits

**Table 32. Request ID Response Bit Definitions**

Bit Field	Definition
D[4:0] = {1'b0, DEVID, 3'b100}	Device Identifier: '00100', or '01100' DEVID: Bit 7 of the DEVCFG register
V[2:0]	Version ID. This field indicates the device / silicon revision of the device.
A[3:0]	DSI device address. This field contains the device address.
	Shaded bits are transmitted to meet the response message length of the received message

#### 4.2.1.6 DSI Command #5

DSI Command '0101' is not implemented. The device ignores all command formats with a command ID of '0101'.

#### 4.2.1.7 DSI Command #6

DSI Command '0110' is not implemented. The device ignores all command formats with a command ID of '0110'.

#### 4.2.1.8 Clear Command

The Clear command is supported in the following command formats:

- Standard Long Command
- Standard Short Command
- Enhanced Long Command as configured by the Format Control Command (Reference [Section 4.2.1.11](#))
- Enhanced Short Command as configured by the Format Control Command (Reference [Section 4.2.1.11](#))

When the device successfully decodes a Clear Command, and the address field matches either the assigned device address (PA[3:0]) or the DSI Global address of '0000', the bus switch is opened within  $T_{BSOPEN}$ , and the device logic is reset. Reference [Section 3.6](#) for the initialization sequence following a Clear Command. The data bits D[7:0] in the command are only used in the CRC calculation. There is no response to the Clear Command.

**Table 33. Clear Command**

Data								Address				Command				CRC
D[7]	D[6]	D[5]	D[4]	D[3]	D[2]	D[1]	D[0]	A[3]	A[2]	A[1]	A[0]	C[3]	C[2]	C[1]	C[0]	
—	—	—	—	—	—	—	—	A[3]	A[2]	A[1]	A[0]	0	1	1	1	0 to 8 bits

**Table 34. Clear Command Bit Definitions**

Bit Field	Definition
C[3:0]	Clear Command = '0111'. When a Clear Command is successfully decoded and the address field matches either the assigned device address or the DSI Global Device Address of '0000', the bus switch is opened within $t_{BSOPEN}$ , and the device logic is reset. Reference <a href="#">Section 3.6</a> for the initialization sequence following a Clear Command.
A[3:0]	DSI device address. This field contains the device address. This field must match the internal programmed address field or the Global Device Address of '0000'. Otherwise, the command is ignored.
D[7:0]	Used for CRC calculation only

#### 4.2.1.9 DSI Command #8

DSI Command '1000' is not implemented. The device ignores all command formats with a command ID of '1000'.

#### 4.2.1.10 Write NVM Command

The Write NVM command is supported in the following command formats:

- Standard Long Command
- Enhanced Long Command as configured by the Format Control Command (Reference [Section 4.2.1.11](#))

The device ignores the Write NVM command if the command is in any other format, or if the DSI device address is set to the DSI Global Device Address of '0000'.

The Write NVM command uses the nibble address definitions in [Table 3](#) and summarized in [Table 40](#).

**Table 35. Write NVM Command**

Data								Address				Command				CRC
D[7]	D[6]	D[5]	D[4]	D[3]	D[2]	D[1]	D[0]	A[3]	A[2]	A[1]	A[0]	C[3]	C[2]	C[1]	C[0]	
WA[3]	WA[2]	WA[1]	WA[0]	RD[3]	RD[2]	RD[1]	RD[0]	A[3]	A[2]	A[1]	A[0]	1	0	0	1	0 to 8 bits

**Table 36. Write NVM Command Bit Definitions**

Bit Field	Definition
C[3:0]	Write NVM Command = '1001'
A[3:0]	DSI device address. This field contains the device address. This field must match the internal programmed address field. Otherwise, the command is ignored.
RD[3:0]	RD[3:0] contains the data to be written to the OTP location addressed by WA[3:0] when the NV bit is set.
WA[3:0]	WA[3:0] contains the nibble address of the OTP register to be written to when the NV bit is set.

**Table 37. Long Response - Write NVM Command (NV = 1)**

Data																CRC
D[15]	D[14]	D[13]	D[12]	D[11]	D[10]	D[9]	D[8]	D[7]	D[6]	D[5]	D[4]	D[3]	D[2]	D[1]	D[0]	
A[3]	A[2]	A[1]	A[0]	WA[3]	WA[2]	WA[1]	WA[0]	1	1	Bank[1]	Bank[0]	RD[3]	RD[2]	RD[1]	RD[0]	0 to 8 bits

**Table 38. Long Response - Write NVM Command (NV = 0)**

Data																CRC
D[15]	D[14]	D[13]	D[12]	D[11]	D[10]	D[9]	D[8]	D[7]	D[6]	D[5]	D[4]	D[3]	D[2]	D[1]	D[0]	
A[3]	A[2]	A[1]	A[0]	0	0	0	0	1	1	1	1	A[3]	A[2]	A[1]	A[0]	0 to 8 bits

**Table 39. Write NVM Response Bit Definitions**

Bit Field	Definition
Bank[1:0]	These bits provide the bank address selected in the Initialization command.
A[3:0]	DSI device address. This field contains the device address. This field must match the internal programmed address field. Otherwise, the command is ignored.
RD[3:0]	RD[3:0] contains the contents of the registers addressed by WA[3:0] after the execution of the NVM write.
WA[3:0]	WA[3:0] contains the nibble address of the OTP register to be written to when the NV bit is set.

Writes to OTP occur only if the NV bit is set. The NV bit is set by the Initialization command (reference [Section 4.2.1.1](#)). If the NV bit is cleared when the command is executed, the mirror registers addressed by WA[3:0] are updated with the contents of RD[3:0] and the DSI Device Address is returned regardless of the WA[3:0] value. If the Write NVM command is a request to change the Device Address, the new Device Address is returned.

The DSI Bus idle voltage must exceed the minimum  $V_{PP}$  voltage when programming the OTP array. No internal verification of the VPP voltage is completed while writing is in process. To verify proper writes, it is recommended that the registers be read back after writes to verify proper contents. The total execution time for the Write NVM command is  $t_{PROG\_BIT}$  times the number of bits being programmed (1 - 4 bits). Inter-frame spacing between the Write NVM command and the subsequent DSI command must accommodate this timing.

Writes to the user programmable OTP array using the Write NVM command will update the mirror registers and result in a change to the error detection calculation regardless of the state of the NV bit and the LOCK\_U bit. An error detection mismatch will only be detected if the LOCK\_U bit is active (reference [Section 3.2.2](#)).

**Table 40. OTP Register Nibble Address Assignments**

Bank Address		Register Address (Nibble)				Register	Description
Bnk[1]	Bnk[0]	WA[3]	WA[2]	WA[1]	WA[0]		
x	x	0	0	0	0	UNUSED	No Write to NVM executed, Normal Response: RD[3:0] = Device Address ADDR[3:0]
x	x	0	0	0	1		
x	x	0	0	1	0		
x	x	0	0	1	1		
x	x	0	1	0	0		
x	x	0	1	0	1		
0	0	0	1	1	0		
0	0	0	1	1	1	DEVCFG2[7]	Only RD[3] is written to the LOCK_U bit
0	0	1	0	0	0	TYPE[7:6]	Only RD[3:2] is written to LPF[1:0]
0	0	1	0	0	1	UNUSED	No Write to NVM executed, Normal Response: RD[3:0] = Device Address ADDR[3:0]
0	0	1	0	1	0	DEVCFG[7:4]	Only RD[3] is written to the DEVID bit
0	0	1	0	1	1	UNUSED	No Write to NVM executed, Normal Response: RD[3:0] = Device Address ADDR[3:0]
0	0	1	1	0	0		
0	0	1	1	0	1		
0	0	1	1	1	0		
0	0	1	1	1	1		
0	1	0	1	1	0	DEVCFG1[3:0]	Only RD[1:0] is written to AT[1:0]
0	1	0	1	1	1	DEVCFG2[3:0]	RD[3:0] is written to ADDR[3:0]
0	1	1	0	0	0	UD01[3:0]	RD[3:0] is written to UD01[3:0]
0	1	1	0	0	1	UD02[3:0]	RD[3:0] is written to UD02[3:0]
0	1	1	0	1	0	UD03[3:0]	RD[3:0] is written to UD03[3:0]
0	1	1	0	1	1	UD04[3:0]	RD[3:0] is written to UD04[3:0]
0	1	1	1	0	0	UD05[3:0]	RD[3:0] is written to UD05[3:0]
0	1	1	1	0	1	UD06[3:0]	RD[3:0] is written to UD06[3:0]
0	1	1	1	1	0	UD07[3:0]	RD[3:0] is written to UD07[3:0]
0	1	1	1	1	1	UNUSED	No Write to NVM executed, Normal Response: RD[3:0] = Device Address ADDR[3:0]
1	0	0	1	1	0	UNUSED	No Write to NVM executed, Normal Response: RD[3:0] = Device Address ADDR[3:0]
1	0	0	1	1	1		
1	0	1	0	0	0		
1	0	1	0	0	1		
1	0	1	0	1	0		
1	0	1	0	1	1		
1	0	1	1	0	0		
1	0	1	1	0	1		
1	0	1	1	1	0		
1	0	1	1	1	1		
1	0	1	1	1	1		
1	1	0	1	1	0		
1	1	0	1	1	1		
1	1	1	0	0	0		
1	1	1	0	0	1		
1	1	1	0	1	0		
1	1	1	0	1	1		
1	1	1	1	0	0		
1	1	1	1	0	1		
1	1	1	1	1	0		
1	1	1	1	1	1		

#### 4.2.1.11 Format Control Command

The Format Control command is supported in the following command formats:

- Standard Long Command
- Enhanced Long Command as configured by the Format Control Command (Reference [Section 4.2.1.11](#))

The device ignores the Format Control command if the command is in any other format. The device supports the Format Control command with the DSI Global Address of '0000', but does not provide a response.

**Table 41. Format Control Command**

Data								Address				Command				CRC
D[7]	D[6]	D[5]	D[4]	D[3]	D[2]	D[1]	D[0]	A[3]	A[2]	A[1]	A[0]	C[3]	C[2]	C[1]	C[0]	
R/W	FA[2]	FA[1]	FA[0]	FD[3]	FD[2]	FD[1]	FD[0]	A[3]	A[2]	A[1]	A[0]	1	0	1	0	0 to 8 bits

**Table 42. Format Control Command Bit Definitions**

Bit Field	Definition
C[3:0]	Format Control Command = '1010'
A[3:0]	DSI device address. This field contains the device address. This field must match the internal programmed address field. Otherwise, the command is ignored.
FD[3:0]	Data to be written to the Format Control Register addressed by FA[2:0] if the R/W bit is set to '1'.
FA[2:0]	The Address of the Format Control Register to read or written.
R/W	Read/Write determines if the register at address FA[2:0] is to be read or written. 1 - Write FD[3:0] to the Format Control Register addressed by FA[2:0] 0 - Read the Format Control Register addressed by FA[2:0]

**Table 43. Long Response - Format Control Command**

Response																CRC
D[15]	D[14]	D[13]	D[12]	D[11]	D[10]	D[9]	D[8]	D[7]	D[6]	D[5]	D[4]	D[3]	D[2]	D[1]	D[0]	
A[3]	A[2]	A[1]	A[0]	0	1	1	0	R/W	FA[2]	FA[1]	FA[0]	FD[3]	FD[2]	FD[1]	FD[0]	0 to 8 bits

**Table 44. Format Control Response Bit Definitions**

Bit Field	Definition
FD[3:0]	The contents of the Format Control Register addressed by FA[2:0].
FA[2:0]	The Address of the Format Control Register that was read or written.
R/W	Read/Write indicates if the register at address FA[2:0] was read or written. 1 - FD[3:0] contains the data written to the Format Control Register addressed by FA[2:0] 0 - FD[3:0] contains the contents for the Format Control Register addressed by FA[2:0]
A[3:0]	DSI device address. This field contains the device address.

The format control registers defined in the DSI Bus Standard V2.5 are shown in [Table 45](#). The reset values assigned to each register are also indicated.

**Table 45. Format Control Register Values**

Format Control Register	Register Address			Reset Values				DSI Standard Values				Definition
	FA[2]	FA[1]	FA[0]	FD[3]	FD[2]	FD[1]	FD[0]	FD[3]	FD[2]	FD[1]	FD[0]	
CRC Polynomial - Low Nibble	0	0	0	0	0	0	1	0	0	0	1	CRC Polynomial = $X^4+1$
CRC Polynomial - High Nibble	0	0	1	0	0	0	1	0	0	0	1	
Seed - Low Nibble	0	1	0	1	0	1	0	1	0	1	0	Seed = '1010'
Seed - High Nibble	0	1	1	0	0	0	0	0	0	0	0	
CRC Length (0 to 8)	1	0	0	0	1	0	0	0	1	0	0	CRC Length = 4
Short Word Data Length (8 to 15)	1	0	1	1	0	0	0	1	0	0	0	Short Command Length = 8
Reserved	1	1	0	0	0	0	0	0	0	0	0	N/A
Format Selection	1	1	1	0	0	0	0	0	0	0	0	N/A

The following restrictions apply to format control register operations:

- Writes to the CRC Length Register of values greater than 8 are ignored. The contents of the register are unchanged.
- Writes to the Short Word Data Length register of values less than 8 are ignored. The contents of the register are unchanged.

The contents of the Format Selection register determine whether the standard DSI values or the values in the format control registers are used. If the Format Selection register contains '1111', the Format Control register values are active. Any write to the Format Control registers will become active upon completion of the write. In this case, the response to a Format Control Command will maintain the format of the previous command resulting in an invalid response.

A write of '0000' to the Format Selection register activates the standard DSI values.

A write to the Format Selection register of any other value is ignored.

#### 4.2.1.12 Read Register Data Command

The Read Register Data command is supported in the following command formats:

- Standard Long Command
- Enhanced Long Command as configured by the Format Control Command (Reference [Section 4.2.1.11](#))

The device ignores the Register Data command if the command is in any other format, or if the DSI device address is set to the DSI Global Device Address of '0000'.

The read register command uses the byte address definitions shown in [Table 3](#). Readable registers along with their Byte addresses are shown in [Table 3](#).

**Table 46. Read Register Data Command**

Data								Address				Command				CRC
D[7]	D[6]	D[5]	D[4]	D[3]	D[2]	D[1]	D[0]	A[3]	A[2]	A[1]	A[0]	C[3]	C[2]	C[1]	C[0]	
0	0	0	0	RA[3]	RA[2]	RA[1]	RA[0]	A[3]	A[2]	A[1]	A[0]	1	0	1	1	0 to 8 bits

**Table 47. Read Register Data Command Bit Definitions**

Bit Field	Definition
C[3:0]	Read Register Data Command = '1011'
A[3:0]	DSI device address. This field contains the device address. This field must match the internal programmed address field. Otherwise, the command is ignored.
RA[3:0]	RA[3:0] contains the byte address of the register to be read.

**Table 48. Long Response - Read Register Data Command**

Data																CRC
D[15]	D[14]	D[13]	D[12]	D[11]	D[10]	D[9]	D[8]	D[7]	D[6]	D[5]	D[4]	D[3]	D[2]	D[1]	D[0]	
A[3]	A[2]	A[1]	A[0]	RA[3]	RA[2]	RA[1]	RA[0]	RD[7]	RD[6]	RD[5]	RD[4]	RD[3]	RD[2]	RD[1]	RD[0]	0 to 8 bits

**Table 49. Read Register Data Response Bit Definitions**

Bit Field	Definition
RD7:0]	RD[7:0] contains the data of the register addressed by RA[3:0].
RA[3:0]	RA[3:0] contains the byte address of the register to be read.
A[3:0]	DSI device address. This field contains the device address. This field must match the internal programmed address field. Otherwise, the command is ignored.

#### 4.2.1.13 Disable Self-Test Command

The Disable Self-Test command is supported in the following command formats:

- Standard Long Command
- Standard Short Command
- Enhanced Long Command as configured by the Format Control Command (Reference [Section 4.2.1.11](#))
- Enhanced Short Command as configured by the Format Control Command (Reference [Section 4.2.1.11](#))

The data bits D[7:0] in the command are only used in the CRC calculation. The device supports the Disable Self-Test command with the DSI Global Address of '0000', but does not provide a response.

The Disable Self-Test Command removes the voltage from the self-test plate of the transducer which results in the acceleration output value returning to the 0g offset value within  $t_{ST\_DEACT\_xxx}$ , as specified in [Section 2](#).

**Table 50. Disable Self-Test Command**

Data								Address				Command				CRC
D[7]	D[6]	D[5]	D[4]	D[3]	D[2]	D[1]	D[0]	A[3]	A[2]	A[1]	A[0]	C[3]	C[2]	C[1]	C[0]	
—	—	—	—	—	—	—	—	A[3]	A[2]	A[1]	A[0]	1	1	0	0	0 to 8 bits

**Table 51. Disable Self-Test Command Bit Definitions**

Bit Field	Definition
C[3:0]	Disable Self-Test Command = '1100'
A[3:0]	DSI device address. This field contains the device address. This field must match the internal programmed address field. Otherwise, the command is ignored.
D[7:0]	Used for CRC calculation only

**Table 52. Short Response - Disable Self-Test Command**

Response															CRC
D[14]	D[13]	D[12]	D[11]	D[10]	D[9]	D[8]	D[7]	D[6]	D[5]	D[4]	D[3]	D[2]	D[1]	D[0]	
0	0	0	0	0	0	0	NV	U	ST	BS	AT[1]	AT[0]	S	0	0 to 8 bits

**Table 53. Long Response - Disable Self-Test Command**

Data																CRC
D[15]	D[14]	D[13]	D[12]	D[11]	D[10]	D[9]	D[8]	D[7]	D[6]	D[5]	D[4]	D[3]	D[2]	D[1]	D[0]	
A[3]	A[2]	A[1]	A[0]	0	0	0	0	NV	U	ST	BS	AT[1]	AT[0]	S	0	0 to 8 bits

**Table 54. Disable Self-Test Response Bit Definitions**

Bit Field	Definition
S	This bit indicates whether the device has detected an internal device error. 1 - Internal Error detected. 0 - No Internal Error detected Reference <a href="#">Table 60</a> for conditions that set the S bit.
AT[1:0]	Attribute bits located in Register DEVCFG1 (Reference <a href="#">Section 3.1.4.1</a> )
BS	Bus Switch state. This bit controls the state of the bus switch: 1 - Close the bus switch 0 - Do not close the bus switch
ST	This bit indicates whether internal self-test circuitry is active 1 - Self-Test active 0 - Self-Test disabled
U	This bit is set if the voltage at HCAP is below the threshold specified in <a href="#">Section 2</a> . Refer to <a href="#">Section 3.3.2</a> for details.
NV	NVM Program Enable. This bit indicates whether programming of the user-programmable OTP locations is enabled. 1 - OTP programming Enabled 0 - OTP programming Disabled
A[3:0]	DSI device address. This field contains the device address.

A self-test lockout is activated when the device receives two consecutive Disable Self-Test commands. Once self-test lockout is activated, the internal self-test circuitry is disabled until one of the following conditions occurs:

- HCAP under-voltage
- A Clear command is received
- Internal regulator under-voltage resulting in a reset.
- A Frame Timeout resulting in a reset.

#### 4.2.1.14 Enable Self-Test Command

The Enable Self-Test command is supported in the following command formats:

- Standard Long Command
- Standard Short Command
- Enhanced Long Command as configured by the Format Control Command (Reference [Section 4.2.1.11](#))
- Enhanced Short Command as configured by the Format Control Command (Reference [Section 4.2.1.11](#))

The data bits D[7:0] in the command are only used in the CRC calculation. The device ignores the Enable Self-Test command when it is sent to the DSI Global Address of '0000'.

The Enable Self-Test Command applies a voltage to the self-test plate of the transducer which results in a delta in the acceleration output value of  $\Delta\text{DFLCT\_xxx}$  within  $t_{\text{ST\_ACT\_xxx}}$ , as specified in [Section 2](#). This remains present until the Disable Self-Test command is received.

Activation of the self-test circuit is inhibited if the self-test locking has been activated. If self-test locking is activated, the internal self-test circuitry remains disabled, and the ST bit is cleared in the response. Self-Test locking is described in [Section 4.2.1.13](#).

**Table 55. Enable Self-Test Command**

Data								Address				Command				CRC
D[7]	D[6]	D[5]	D[4]	D[3]	D[2]	D[1]	D[0]	A[3]	A[2]	A[1]	A[0]	C[3]	C[2]	C[1]	C[0]	
—	—	—	—	—	—	—	—	A[3]	A[2]	A[1]	A[0]	1	1	0	1	4 bits

**Table 56. Enable Self-Test Command Bit Definitions**

Bit Field	Definition
C[3:0]	Enable Self-Test Command = '1101'
A[3:0]	DSI device address. This field contains the device address. This field must match the internal programmed address field. Otherwise, the command is ignored.
D[7:0]	Used for CRC calculation only

**Table 57. Short Response - Enable Self-Test Command**

Response														CRC	
D[14]	D[13]	D[12]	D[11]	D[10]	D[9]	D[8]	D[7]	D[6]	D[5]	D[4]	D[3]	D[2]	D[1]		D[0]
0	0	0	0	0	0	0	NV	U	ST	BS	AT[1]	AT[0]	S	0	4 bits

**Table 58. Long Response - Enable Self-Test Command**

Data															CRC	
D[15]	D[14]	D[13]	D[12]	D[11]	D[10]	D[9]	D[8]	D[7]	D[6]	D[5]	D[4]	D[3]	D[2]	D[1]		D[0]
A[3]	A[2]	A[1]	A[0]	0	0	0	0	NV	U	ST	BS	AT[1]	AT[0]	S	0	4 bits

**Table 59. Enable Self-Test Response Bit Definitions**

Bit Field	Definition
S	This bit indicates whether the device has detected an internal device error. 1 - Internal Error detected. 0 - No Internal Error detected Reference <a href="#">Table 60</a> for conditions that set the S bit.
AT[1:0]	Attribute bits located in Register DEVCFG1 (Reference <a href="#">Section 3.1.4.1</a> )
BS	Bus Switch state. This bit controls the state of the bus switch: 1 - Close the bus switch 0 - Do not close the bus switch
ST	This bit indicates whether internal self-test circuitry is active 1 - Self-Test active 0 - Self-Test disabled
U	This bit is set if the voltage at HCAP is below the threshold specified in <a href="#">Section 2</a> . Refer to <a href="#">Section 3.3.2</a> for details.
NV	NVM Program Enable. This bit indicates whether programming of the user-programmable OTP locations is enabled. 1 - OTP programming Enabled 0 - OTP programming Disabled
A[3:0]	DSI device address. This field contains the device address.

#### 4.2.1.15 DSI Command #14

DSI Command '1110' is not implemented. The device ignores all command formats with a command ID of '1110'.

#### 4.2.1.16 Reverse Initialization Command

The Reverse Initialization Command is not implemented. The device ignores all command formats with a command ID of '1111'. The device ignores all command received on the BUSOUT pin.

### 4.3 Exception Handling

Table 60 summarizes the exception conditions detected by the device and the response for each exception.

Table 60. Exception Handling

Condition		Description	S	ST	U	Response
Exception	Self-Test Request					
Power On Reset	N/A	Power Applied Clear Command	1	1	0	– Reference <a href="#">Section 3.6</a>
$V_{REG}$ Under-Voltage	N/A	$V_{REG} < V_{PORCREG\_f}$				– Device held in Reset. – No response to DSI commands. – Bus switch open within $t_{BSOPEN}$ . – Device must be re-initialized when $V_{REG}$ returns above $V_{PORCREG\_f}$
$V_{REGA}$ Under-Voltage	N/A	$V_{REGA} < V_{PORCREG\_f}$				– Device held in Reset. – No response to DSI commands. – Bus switch open within $t_{BSOPEN}$ . – Device must be re-initialized when $V_{REGA}$ returns above $V_{PORCREGA\_f}$
$V_{HCAP}$ Under-Voltage Transient	Disabled	$V_{HCAP} < V_{PORCREG\_f}$ for less than $t_{HCAP\_POR}$ , ST Disabled	0	0	1	– DSI Read Acceleration Data Short response = zero. – DSI Read Acceleration Data Long response = normal. – Device does not need to be re-initialized if $V_{HCAP}$ returns above $V_{PORHCAP\_f}$ before $t_{HCAP\_POR}$
	Enabled	$V_{HCAP} < V_{PORCREG\_f}$ for less than $t_{HCAP\_POR}$ , ST Enabled	0	1	1	– DSI Read Acceleration Data Short response = self-test data. – DSI Read Acceleration Data Long response = self-test data. – Device does not need to be re-initialized if $V_{HCAP}$ returns above $V_{PORHCAP\_f}$ before $t_{HCAP\_POR}$
$V_{HCAP}$ Under-Voltage	N/A	$V_{HCAP} < V_{PORCREG\_f}$ for longer than $t_{HCAP\_POR}$				– Device is Reset and will continue to Reset every $t_{HCAP\_POR}$ until $V_{HCAP}$ returns above $V_{PORHCAP\_f}$ , or an internal supply under-voltage condition occurs. – No response to DSI commands. – Bus switch open within $t_{BSOPEN}$ . – Device must be re-initialized when $V_{HCAP}$ returns above $V_{PORHCAP\_f}$
Capacitor Test Failure	N/A					– Device is Reset and will continue to be reset every $t_{POR\_CAPTEST}$ until the capacitor failure is removed. – No response to DSI commands. – Bus switch open within $t_{BSOPEN}$ . – Device must be re-initialized when capacitor failure is removed.
DSI Frame Timeout	N/A	$V_{BUSIN} < V_{THF}$ for longer than $t_{TO}$				– Device is Reset and will continue to be reset every $t_{TO}$ until the $BUSIN$ voltage returns above $V_{THF}$ or a supply under-voltage condition occurs. – No response to DSI commands. – Bus switch open within $t_{BSOPEN}$ . – Device must be re-initialized when $V_{BUSIN}$ returns above $V_{THF}$
Fuse CRC Fault (Factory Array)	Disabled	CRC failure detected in factory programmed OTP array and the LOCK_F bit is set. ST Disabled	1	0	0	– DSI Read Acceleration Data Short response = zero. – DSI Read Acceleration Data Long response = normal.
	Enabled	CRC failure detected in factory programmed OTP array and the LOCK_F bit is set. ST Enabled	1	1	0	– DSI Read Acceleration Data Short response = zero. – DSI Read Acceleration Data Long response = self-test data.
Fuse Error Detection Fault (User Array)	Disabled	Mismatch detected in User programmed OTP array and the LOCK_U bit is set. ST Disabled	1	0	0	– DSI Read Acceleration Data Short response = zero. – DSI Read Acceleration Data Long response = normal.
	Enabled	Mismatch detected in User programmed OTP array and the LOCK_U bit is set. ST Enabled	1	1	0	– DSI Read Acceleration Data Short response = zero. – DSI Read Acceleration Data Long response = self-test data.
Self-Test Enabled	Enabled	ST Enabled	1	1	0	– Internal self-test circuitry enabled. – DSI Read Acceleration Data Short response = self-test data. – DSI Read Acceleration Data Long response = self-test data.
Self-Test Lockout	Disabled	Two consecutive Disable Self-Test DSI commands received.	0	0	0	– Internal self-test circuitry disabled. – Enable Self-Test DSI command does not enable Self-Test. Normal response to Enable Self-Test DSI command except the ST bit is not set. – DSI Clear command or Reset disables lockout.

## 5 Package

### 5.1 Case Outline Drawing

Reference Freescale Case Outline Drawing # 98ASA00090D

[http://www.freescale.com/files/shared/doc/package\\_info/98ASA00090D.pdf](http://www.freescale.com/files/shared/doc/package_info/98ASA00090D.pdf)

### 5.2 Recommended Footprint

Reference Freescale Application Note AN3111, latest revision:

[http://www.freescale.com/files/sensors/doc/app\\_note/AN3111.pdf](http://www.freescale.com/files/sensors/doc/app_note/AN3111.pdf)

Table 61. Revision History

Revision number	Revision date	Description of changes
4	03/2012	<ul style="list-style-type: none"><li>Added SafeAssure logo, changed first paragraph and disclaimer to include trademark information.</li></ul>
5	09/2012	<ul style="list-style-type: none"><li>Section 2.3: Removed Temperature Monitoring Characteristic, lines 36 and 37.</li><li>Section 2.4: Changed Min values for BUSIN Bias Current lines 42 and 43 from -100 to 0 and Min values BUSOUT Bias Current lines 44 and 53 from "-100" to "0".</li><li>Section 2.7: updated line109 in table; Following Read Write NVM Command Min value was 2 changed to 12. Deleted line 115 OTP Program Timing.</li><li>Section 3: Global change all instances of "CRC check" to "error detection and several instances of "CRC verification" to "error detection".</li><li>Table 2: Updated byte address \$05 Bits 6-3 from "UNUSED" to "0", Bits 2-1 from "CRC_U[x]" to "0". \$06: Bits 7-2 from "UD00[x]" to "0". \$07; Bit 6 was "UNUSED" changed to "0". Bit Function 4 was RESERVED, changed to "0". \$0F Bits 3-0 from "UD08[x]" to "0".</li><li>Table 4: Changed bits 3-0 from "CRC_U[x]" to "0".</li><li>Deleted Section 3.1.3.2.</li><li>Table 5: Changed bits 7-2 from "UD00[x]" to "0".</li><li>Deleted Section 3.1.4.1.</li><li>Table 3.1.6: Row \$0F, Bits 3-0 from "UD08[x]" to "0".</li><li>Section 3.2.2: Updated and deleted paragraphs. Deleted "Included In User CRC?" column in second table, deleted rows "User Data Register 0", "RESERVED Bit", "User Programmable OTP Array CRC" and "User Programmable OTP Array Lock Bit".</li><li>Table 6: Updated Bit Function 6 was UNUSED changed to "0". Bit Function 4 was RESERVED, changed to "0".</li><li>Table 39: Changed registers for DEVCGF[3:0], DEVCGF[7:4], DEVCGF1[3:0], UDD8[3:0], DEVCGF1[7:4], DEVCFG2[4], and DEVCGF2[6] and updated descriptions.</li><li>Table 59: Row "Fuse CRC Fault" updated descriptions for Disabled and Enabled. Removed "Temperature Out of Range" row.</li></ul>
5.1	03/2012	<ul style="list-style-type: none"><li>Table 1: Updated description for C1 and C2.</li></ul>

---

**How to Reach Us:**

**Home Page:**

freescale.com

**Web Support:**

freescale.com/support

Information in this document is provided solely to enable system and software implementers to use Freescale products. There are no express or implied copyright licenses granted hereunder to design or fabricate any integrated circuits based on the information in this document.

Freescale reserves the right to make changes without further notice to any products herein. Freescale makes no warranty, representation, or guarantee regarding the suitability of its products for any particular purpose, nor does Freescale assume any liability arising out of the application or use of any product or circuit, and specifically disclaims any and all liability, including without limitation consequential or incidental damages. "Typical" parameters that may be provided in Freescale data sheets and/or specifications can and do vary in different applications, and actual performance may vary over time. All operating parameters, including "typicals," must be validated for each customer application by customer's technical experts. Freescale does not convey any license under its patent rights nor the rights of others. Freescale sells products pursuant to standard terms and conditions of sale, which can be found at the following address: [freescale.com/salestermsandconditions](http://freescale.com/salestermsandconditions).

Freescale, the Freescale logo, AltiVec, C-5, CodeTest, CodeWarrior, ColdFire, C-Ware, Energy Efficient Solutions logo, Kinetis, mobileGT, PowerQUICC, Processor Expert, QorIQ, Qorivva, StarCore, Symphony, and VortiQa are trademarks of Freescale Semiconductor, Inc., Reg. U.S. Pat. & Tm. Off. Airfast, BeeKit, BeeStack, ColdFire+, CoreNet, Flexis, MagniV, MXC, Platform in a Package, QorIQ Qonverge, QUICC Engine, Ready Play, SafeAssure, SMARTMOS, TurboLink, Vybrid, and Xtrinsic are trademarks of Freescale Semiconductor, Inc. All other product or service names are the property of their respective owners.

© 2012 Freescale Semiconductor, Inc.

Document Number: MMA16xxKW

Rev. 5.1

03/2013

