

Power Distribution Switch with Adjustable Current Limit

Features

- Integrated P-channel MOSFET power switch
- Input voltage: 2.5V to 5.5V
- 0.4~2.5A adjustable current Limit:
- Switch on-resistance(typ.):
 $R_{dson}=65m\Omega$ at $V_{IN}=5V$
- $\pm 9\%$ current limit accuracy at 1A(typ.)
- Reverse current protection
- Internal EN pull-down resistor
- Under voltage lockout
- Over temperature protection
- Quick Output Discharge(QOD)
 - ◇ AW35015D/AW35065D: Auto QOD
 - ◇ AW35015/AW35065: No QOD
- SOT23-5L package

General Description

The AW35015D/AW35065D/AW35015/AW35065 is a P-channel MOSFET power distribution switch which intended for high-side load-switching applications. The device integrates adjustable current limit function with an external resistor from ISET pin to ground.

The AW35015D/AW35065D/AW35015/AW35065 also features fast short-circuit response, under voltage lockout, over temperature protection, reverse current protection. The AW35015D/AW35065D builds in quick output discharge function.

Set adjustable current limit:

AW35015D AW35015	$I_{LIMIT}=6800/R_{SET}$
AW35065D AW35065	$I_{LIMIT}=26000/R_{SET}$

Applications

USB Ports

Power Distribution Switch

Notebook and Desktop Computer

High-Definition Television(HDTV)

Typical Application Circuit

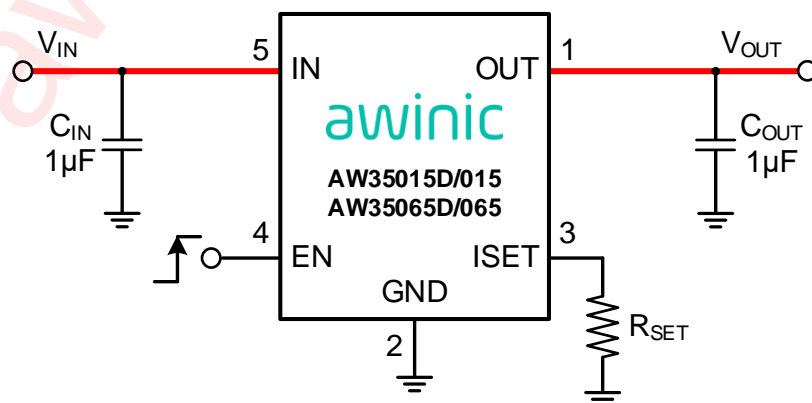
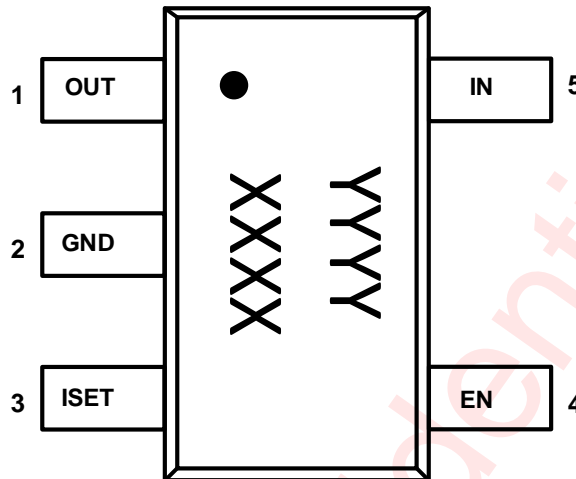

Figure 1 Typical Application Circuit of AW35015D/065D/015/065

Pin Configuration And Top Mark

AW35015/AW35015D/AW35065/AW35065DSTR Marking

(Top View)



YYYY - AW35015/AW35015D/AW35065/AW35065DSTR

XXXX - Production Tracing Code

Figure 2 Pin Configuration and Top Mark

Pin Definition

Pin	Name	Description
1	OUT	Output pin
2	GND	Ground
3	ISET	Current limit threshold setting pin
4	EN	Chip enable (Active High)
5	IN	Power supply input

Functional Block Diagram

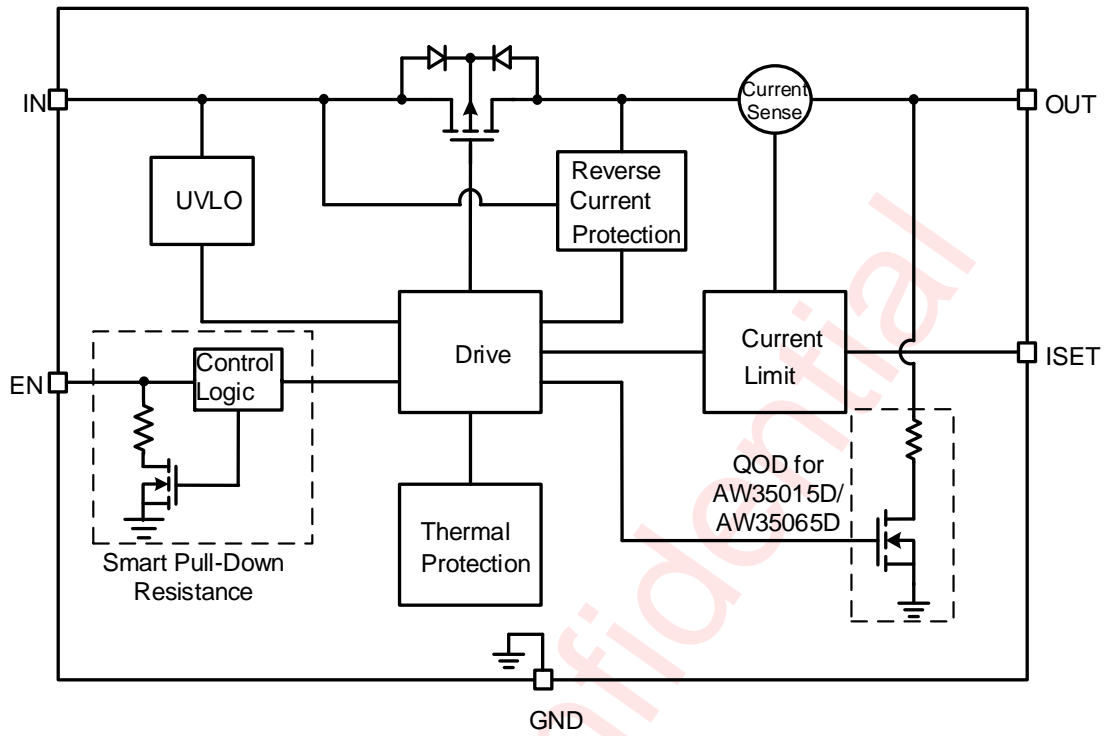

Figure 3 Functional Block Diagram

Typical Application Circuits

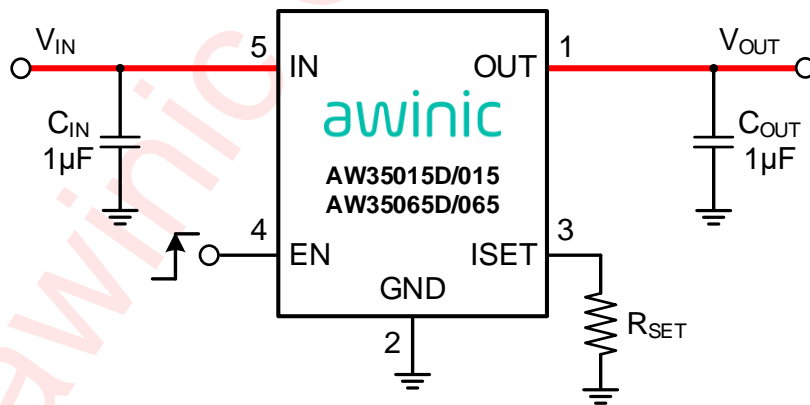

Figure 4 Typical Application Circuit of AW35015D/065D/015/065

Ordering Information

Part Number	Temperature	Package	Marking	Moisture Sensitivity Level	Environmental Information	Delivery Form
AW35015DSTR	-40°C ~ 85°C	SOT23-5L	36UA	MSL3	ROHS+HF	3000 units/ Tape and Reel
AW35065DSTR	-40°C ~ 85°C	SOT23-5L	CXZG	MSL3	ROHS+HF	3000 units/ Tape and Reel
AW35015STR	-40°C ~ 85°C	SOT23-5L	U7YF	MSL3	ROHS+HF	3000 units/ Tape and Reel
AW35065STR	-40°C ~ 85°C	SOT23-5L	BNDT	MSL3	ROHS+HF	3000 units/ Tape and Reel

Absolute Maximum Ratings^(NOTE1)

PARAMETERS		RANGE
Supply Voltage Range V_{IN}		-0.3V to 6V
EN Voltage Range	EN	-0.3V to 6V
Output Voltage Range	OUT	-0.3V to 6V
Maximum Continuous Switch Current for $V_{IN} \geq 2.5V$ ^(NOTE 2)		2.5A
Maximum Peak Switch Current for $V_{IN} \geq 2.5V$ ^(NOTE 3)		3A
Operating Free-air Temperature Range		-40°C to 85°C
Maximum Junction Temperature T_{JMAX}		155°C
Storage Temperature T_{STG}		-65°C to 150°C
Lead Temperature (Soldering 10 Seconds)		260°C
ESD		
HBM (Human Body Model) ^(NOTE 4)		±2kV
CDM(Charged Device Model) ^(NOTE 5)		±1.5kV
Latch-Up		
Latch-Up ^(NOTE 6)		+IT: 200mA -IT: -200mA

NOTE1: Conditions out of those ranges listed in "absolute maximum ratings" may cause permanent damages to the device. In spite of the limits above, functional operation conditions of the device should within the ranges listed in "recommended operating conditions". Exposure to absolute-maximum-rated conditions for prolonged periods may affect device reliability.

NOTE2: Limited by thermal design.

NOTE3: Limited by thermal design, and tested in 10ms width pulse current.

NOTE4: The human body model is a 100pF capacitor discharged through a 1.5kΩ resistor into each pin. Test method: ESDA/JEDEC JS-001-2017.

NOTE5: All pins. Test Condition: ESDA/JEDEC JS-002-2018.

NOTE6: Test Condition: JESD78E.

Recommended Operating Conditions

Symbol	Parameter	Min.	Typ.	Max.	Unit
V_{IN}	Input Voltage	2.5		5.5	V
V_{EN}	EN Voltage	0		5.5	V
V_{OUT}	Output Voltage	0		V_{IN}	V
C_{IN}	Input capacitance	0.1	1		μF
C_{OUT}	Output load capacitance	0.1	1		μF

Electrical Characteristics

T_A = 25°C unless otherwise noted. Typical values are guaranteed for V_{IN} = 5V, C_{IN} = 1μF, I_{IN} ≤ 2.5A.

PARAMETER		TEST CONDITION	MIN	TYP	MAX	UNIT	
SUPPLY CURRENT							
I _Q	Input quiescent current	V _{IN} =5.0V, V _{EN} =5.0V, I _{OUT} =0A		25	50	μA	
I _{SD}	Shutdown current from IN to GND	V _{IN} =5.0V, V _{EN} =0V		0.32	1	μA	
I _{LEAKEN}	EN pin leakage current	V _{IN} =0V, V _{EN} =5.5V		0.52	1	μA	
POWER SWITCH							
R _{dson}	Internal switch MOSFET on-state resistance	V _{IN} =5.0V, V _{EN} =high, I _{OUT} =500mA		65		mΩ	
R _{EN}	EN pin pull down resistor	V _{EN} =5.0V		9.2		MΩ	
R _{DIS}	Output discharge resistance	V _{IN} =5.0V, V _{EN} =low, I _{OUT} Sinking 2mA (for AW35015D/AW35065D)		75		Ω	
t _R	Output rise time	V _{IN} =5.0V, C _{OUT} =1μF, R _{OUT} =100Ω		130		μs	
t _{ON}	Switch turn on time	V _{IN} =5.0V, C _{OUT} =1μF, R _{OUT} =100Ω		294		μs	
t _F	Output fall time	V _{IN} =5.0V, C _{OUT} =1μF, R _{OUT} =100Ω		73		μs	
t _{OFF}	Switch turn off time	V _{IN} =5.0V, C _{OUT} =1μF, R _{OUT} =100Ω		75		μs	
V _{IH}	EN input high threshold level		1.4			V	
V _{IL}	EN input low threshold level				0.4	V	
CURRENT LIMIT							
I _{LIMIT}	Current limit threshold	V _{OUT} =4.4V	R _{SET} =2.72kΩ for AW35015D/015 R _{SET} =10.4kΩ for AW35065D/065	2000	2500	3000	mA
			R _{SET} =3.4kΩ for AW35015D/015 R _{SET} =13kΩ for AW35065D/065	1790	2000	2330	
			R _{SET} =6.8kΩ for AW35015D/015 R _{SET} =26kΩ for AW35065D/065	910	1000	1090	
			R _{SET} =17kΩ for AW35015D/015 R _{SET} =65kΩ for AW35065D/065	340	400	430	
t _{IOS}	Response time to short circuit	V _{IN} =5.0V		10		μs	

Electrical Characteristics (continued)

T_A = 25°C unless otherwise noted. Typical values are guaranteed for V_{IN} = 5V, C_{IN} = 1μF, I_{IN} ≤ 2.5A.

PARAMETER		TEST CONDITION	MIN	TYP	MAX	UNIT
t _{ocp}	Current limit response time	V _{IN} =5.0V, I _{LOAD} =1.5 × I _{LIMIT}		1		ms
UNDER VOLTAGE LOCKOUT						
V _{UVLO}	UVLO threshold voltage	V _{IN} rising		2.3	2.5	V
V _{UVLO_HYS}	UVLO hysteresis	V _{IN} falling		95		mV
REVERSE VOLTAGE PROTECT						
V _{REV}	Reverse voltage trip point	V _{EN} =High, V _{OUT} > V _{IN}		43		mV
I _{REV}	Reverse leakage current	V _{OUT} =5V, V _{IN} =0V, V _{EN} =0V		0.68		μA
I _{REV_AC T}	Reverse activation current	V _{IN} =5V, C _{OUT} =1μF, V _{OUT} > V _{IN}		0.6		A
I _{REV_PRO}	Reverse protection current	V _{OUT} - V _{IN} > V _{REV}		5		μA
THERMAL PROTECTION						
T _{SD}	Thermal shutdown threshold			155		°C
T _{SD_HYS}	Thermal shutdown hysteresis			25		°C

Timing Diagram

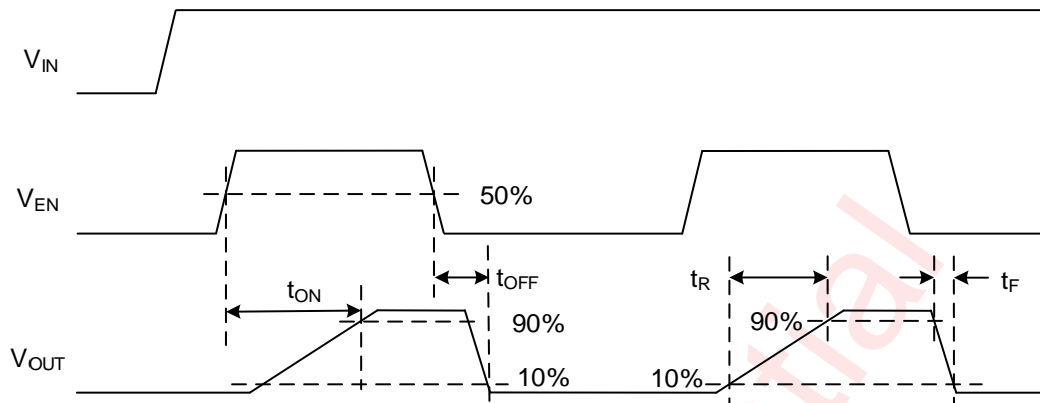

Figure 5 AW35015D/AW35065D/ AW35015/AW35065 Timing Diagram

Typical Characteristics

Ambient temperature is 25°C, $C_{IN} = C_{OUT} = 1\mu F$, unless otherwise noted.

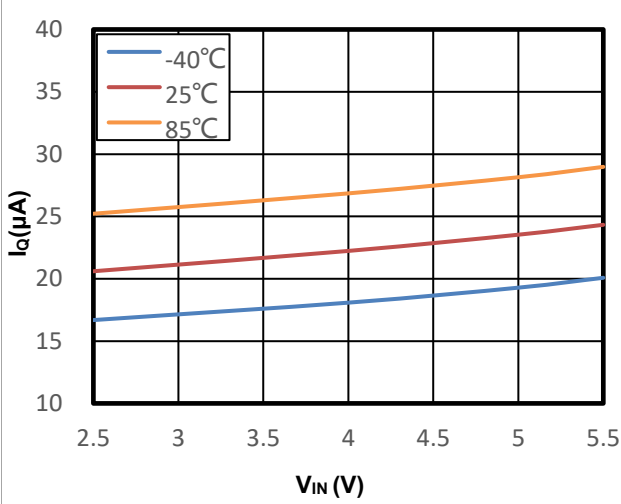

Figure 6 Quiescent Current vs. V_{IN} , No load

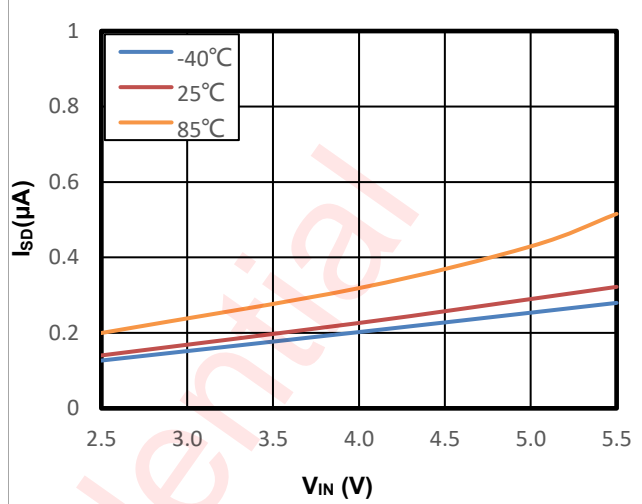

Figure 7 IN Shutdown Current vs. V_{IN}

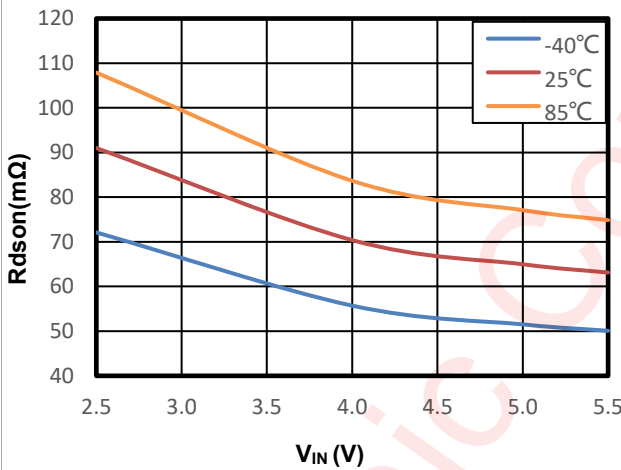

Figure 8 R_{dson} vs. V_{IN} ($I_{OUT} = 500mA$)

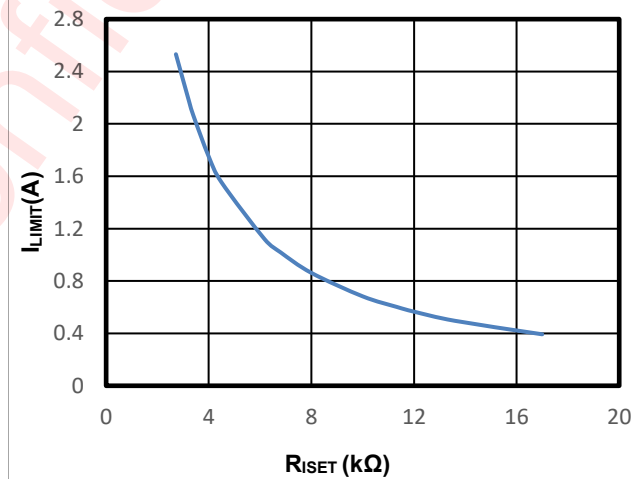

Figure 9 I_{LIMIT} vs. R_{iset} (AW35015D)

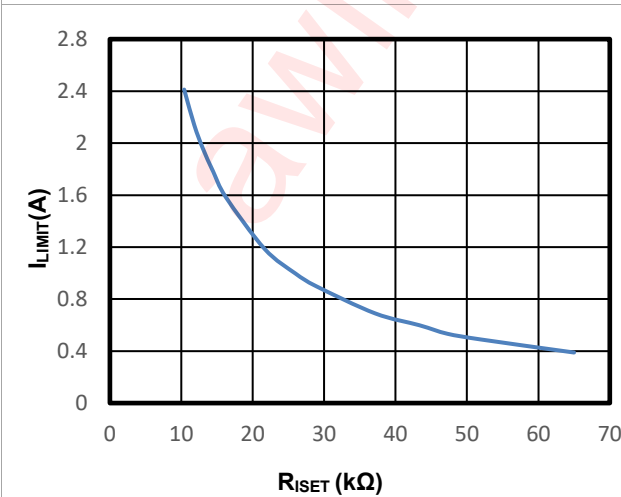

Figure 10 I_{LIMIT} vs. R_{iset} (AW35065D)

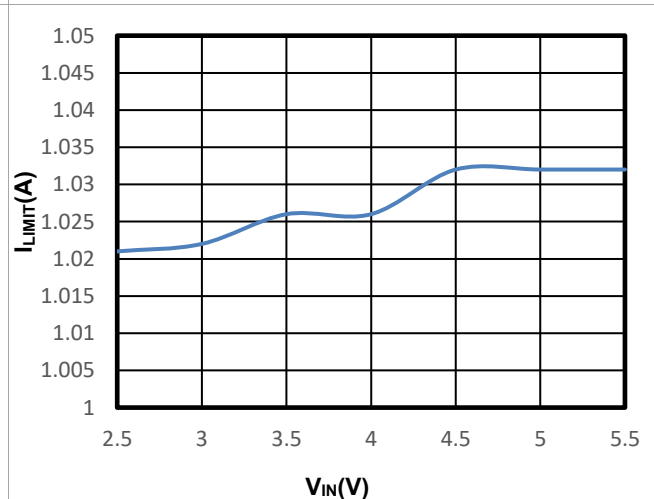

Figure 11 I_{LIMIT} vs. V_{IN}

Typical Characteristics (continued)

Ambient temperature is 25°C, $C_{IN} = C_{OUT} = 1\mu F$, unless otherwise noted.

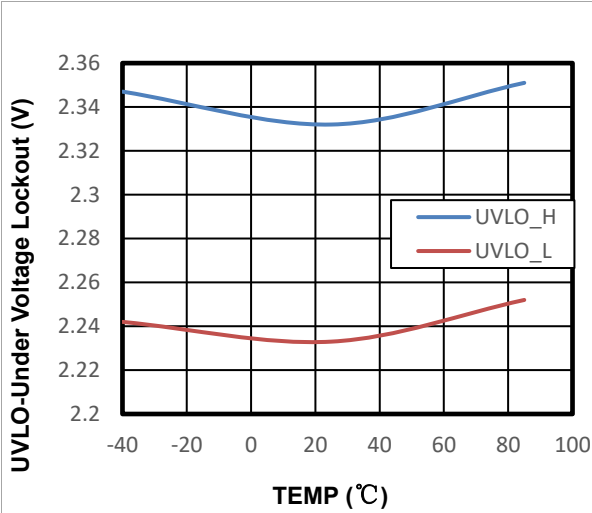
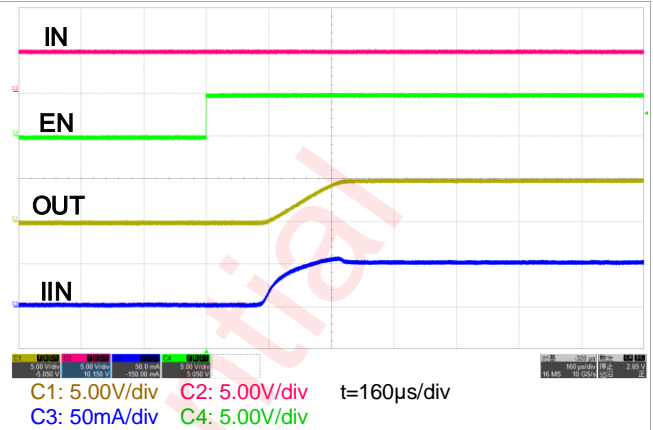
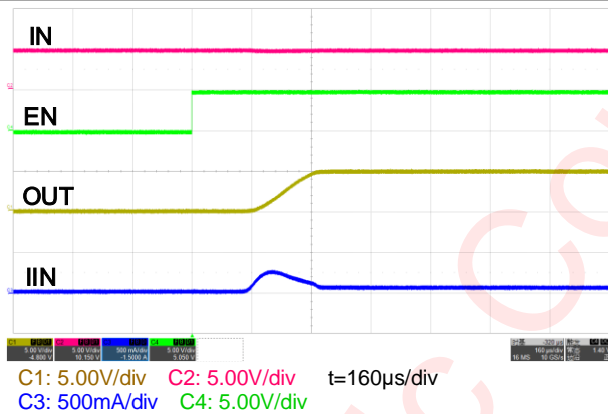

Figure 12 UVLO vs. TEMP



$V_{IN} = 5V$, $C_{IN} = 1\mu F$, $C_{OUT} = 1\mu F$, Set $I_{LIMIT} = 1.0A$, $R_L = 100\Omega$

Figure 13 Turn On Response



$V_{IN} = 5V$, $C_{IN} = 1\mu F$, $C_{OUT} = 10\mu F$, Set $I_{LIMIT} = 1.0A$, $R_L = 100\Omega$

Figure 14 Turn On Response

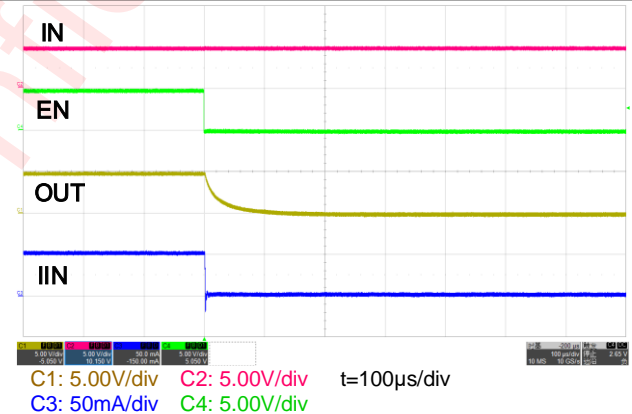

$V_{IN} = 5V$, $C_{IN} = 1\mu F$, $C_{OUT} = 1\mu F$, Set $I_{LIMIT} = 1.0A$, $R_L = 100\Omega$

Figure 15 Turn Off Response

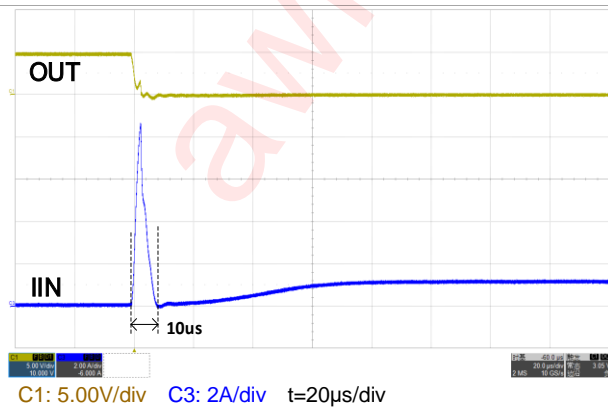

$V_{IN} = 5V$, $C_{IN} = 1\mu F$, $C_{OUT} = 1\mu F$, Set $I_{LIMIT} = 1.0A$

Figure 16 Short Circuit Response

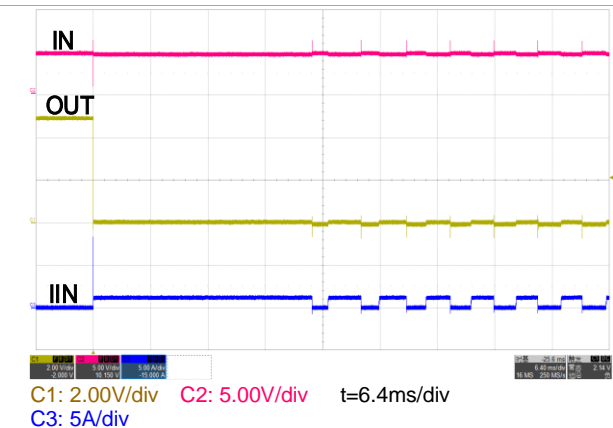

$V_{IN} = 5V$, $C_{IN} = 1\mu F$, $C_{OUT} = 1\mu F$, Set $I_{LIMIT} = 1.0A$

Figure 17 Continuous Short Response

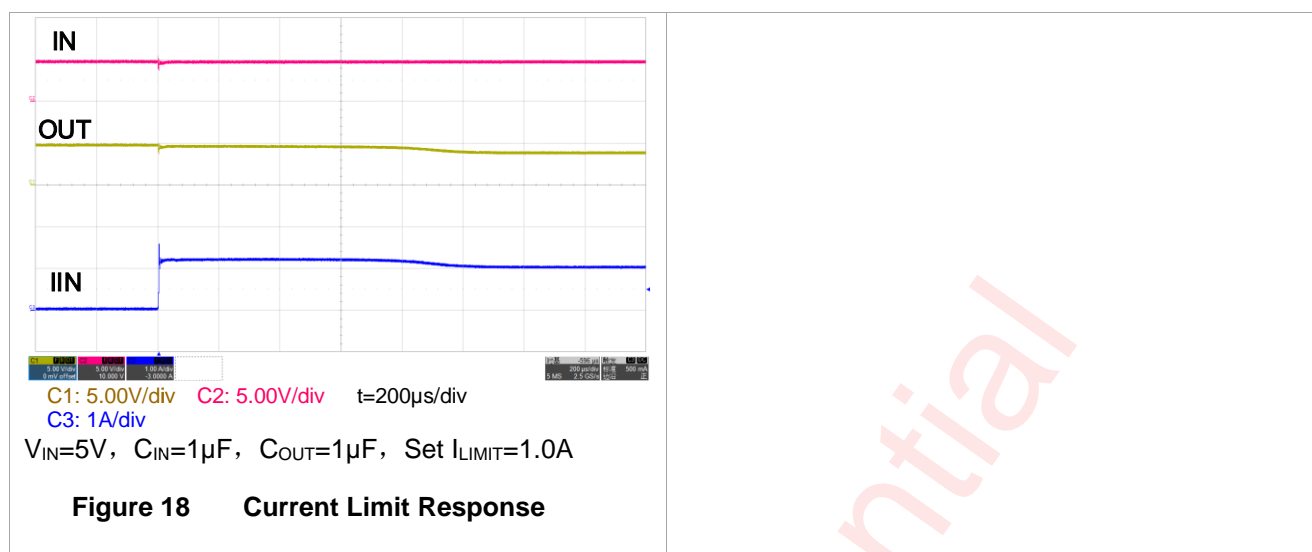

Functional Description

The AW35015D/AW35065D/AW35015/AW35065 is a P channel MOSFET power distribution switch with current limit function. In addition, the switch also features fast short-circuit response, under voltage lockout, over temperature protection and reverse current protection.

CURRENT LIMIT THRESHOLD SETTING

The AW35015D/AW35065D/AW35015/AW35065 provides adjustable current limit threshold which implemented by an external resistor from ISET to ground, see figure 9 and figure 10. The current limit function can prevent the switch from over current condition. The current limit function can prevent the switch from over current condition. The adjustable current limit value can be calculated using the following equations:

AW35015D/AW35015	$I_{LIMIT}=6800/R_{SET}$
AW35065D/AW35065	$I_{LIMIT}=26000/R_{SET}$

The minimum current limit is 400mA, beyond 2.5A is forbidden.

FAST SHORT CIRCUIT PROTECTION

The AW35015D/AW35065D/AW35015/AW35065 provides short circuit protection function which can limit the output current to a safe level without damaging the switch.

UNDER VOLTAGE LOCKOUT (UVLO)

The AW35015D/AW35065D/AW35015/AW35065 has under voltage lockout function which can disable the switch until the input voltage reaches the UVLO threshold (typical 2.3V). The UVLO threshold has a 95mV hysteresis voltage which can prevent the unwanted on/off cycling when there is noise on the input voltage.

OVER TEMPERATURE PROTECTION (OTP)

When the junction temperature exceeds 155°C, the internal OTP circuit turn off the power switch. There is a temperature hysteresis 25°C, in other words, the OTP circuit can turn on the switch only if the junction temperature is below 130°C.

QUICK OUTPUT DISCHARGE(QOD)

The AW35015D/AW35065D include the Quick Output Discharge (QOD) feature, in order to discharge the application capacitor connected on OUT pin. When EN pin is set to low level, a discharge resistance with a typical value of 75Ω is connected between the output and ground, pull down the output and prevent it from floating when the device is disabled.

REVERSE CURRENT PROTECTION (RCP)

The AW35015D/AW35065D/AW35015/AW35065 includes the Reverse Current Protection(RCP) function, which can prevent the current to flowing through the P-FET or the body diode when V_{OUT} greater than V_{IN} . Whatever the switch is on or off, the AW35015D/AW35065D/AW35015/AW35065 always has this function. When $V_{OUT}-V_{IN}$ greater than V_{REV} , the internal comparator quickly turns off the switch, in order to prevent large reverse current from V_{OUT} to V_{IN} . The switch will return to normal operation once the reverse voltage scenario disappeared.

The I_{REV_ACT} parameter in the figure 19 can be calculated by the following formula: $I_{REV_ACT} = \frac{V_{REV}}{R_{dson}}$

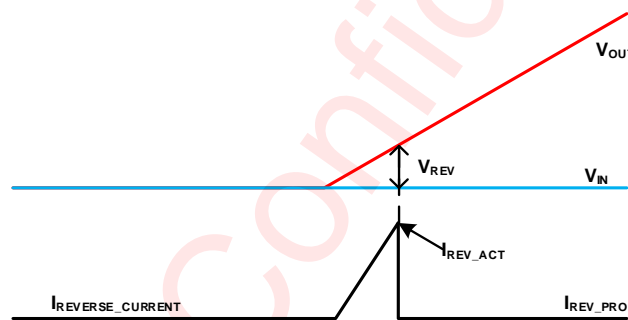

Figure 19 RCP parameter diagram

PCB Layout Consideration

AW35015D/AW35065D/AW35015/AW35065 is a low ON-Resistance power switch, to obtain the optimal performance, PCB layout should be considered carefully. Here are some guidelines:

1. All the peripherals should be placed as close to the device as possible. Place the input capacitor C_{IN} on the top layer (same layer as the AW35015D/AW35065D/AW35015/AW35065) and close to IN pin, and place the output capacitor C_{OUT} on the top layer (same layer as the AW35015D/AW35065D/AW35015/AW35065) and close to OUT pin.
2. The AW35015D/AW35065D/AW35015/AW35065 integrates an up to 2.5A rated PMOS FET, and the PCB design rules must be respected to properly evacuate the heat out of the silicon. By increasing PCB area, especially around IN and OUT pins, the $R_{\theta JA}$ of the package can be decreased, allowing higher power dissipation. Blue bold paths on figure 20 are power lines that will flow large current, please route them on PCB as straight, wide and short as possible.
3. Use rounded corners on the power trace from the power supply connector to AW35015D/AW35065D/AW35015/AW35065 to decrease EMI coupling.

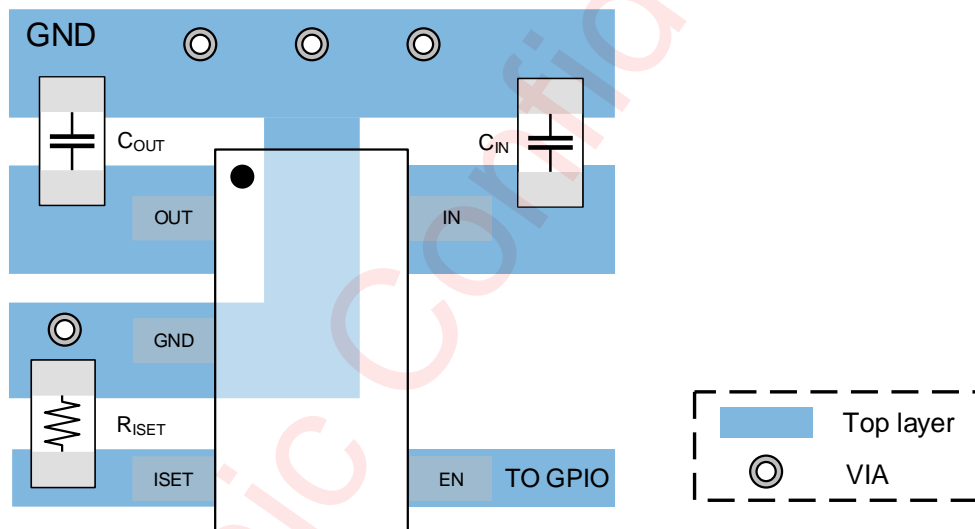
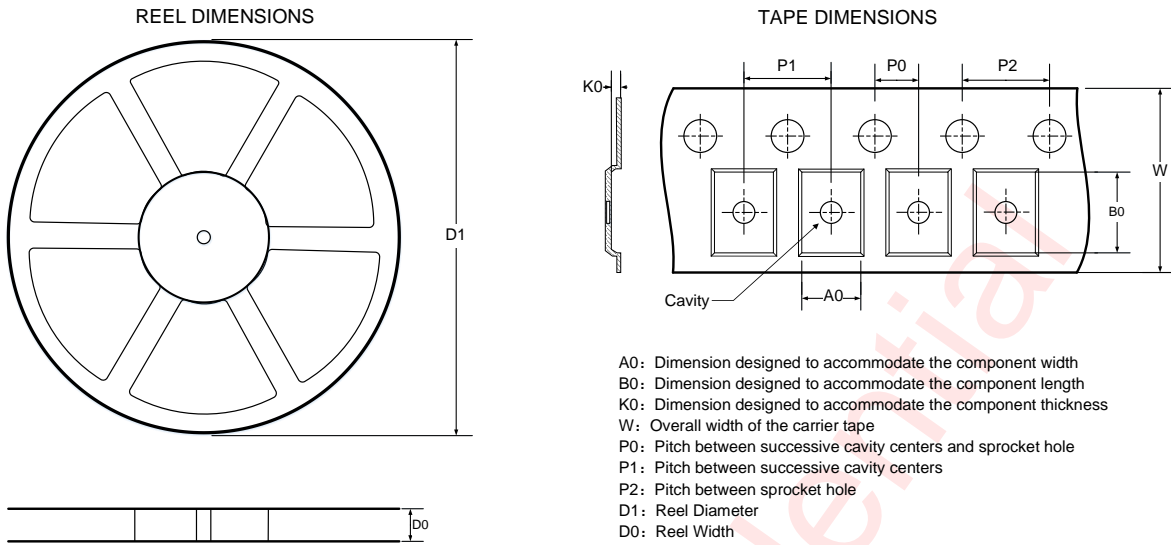
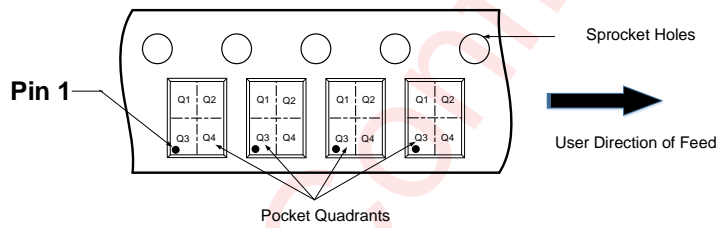

Figure 20 PCB layout example

Tape And Reel Information



QUADRANT ASSIGNMENTS FOR PIN 1 ORIENTATION IN TAPE



Note: The above picture is for reference only. Please refer to the value in the table below for the actual size

DIMENSIONS AND PIN1 ORIENTATION

D1 (mm)	D0 (mm)	A0 (mm)	B0 (mm)	K0 (mm)	P0 (mm)	P1 (mm)	P2 (mm)	W (mm)	Pin1 Quadrant
178	8.5	3.3	3.2	1.4	2	4	4	8	Q3

All dimensions are nominal

Package Description

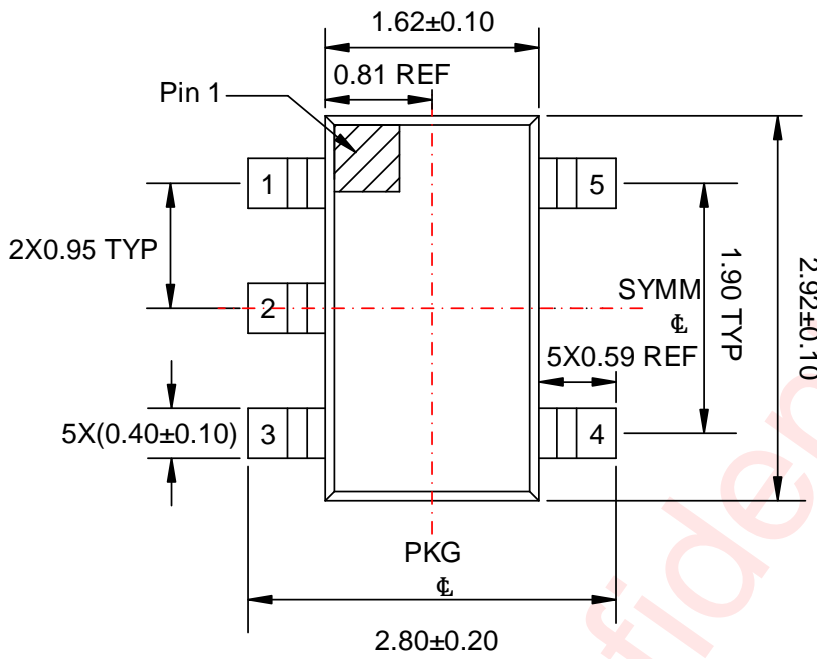

Top View

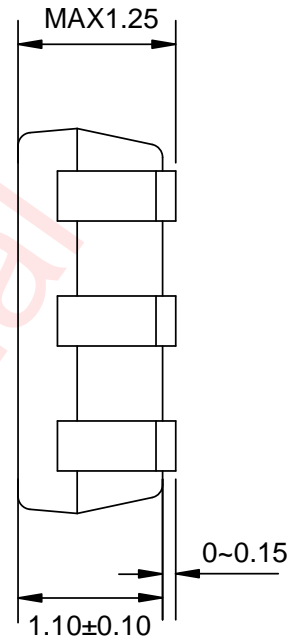

Side View

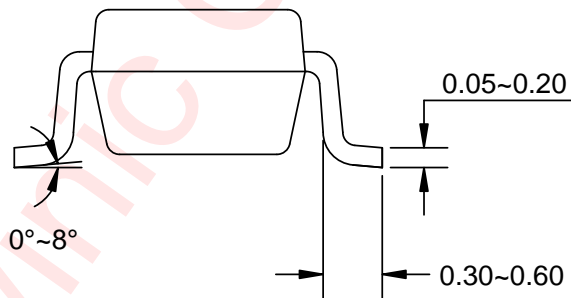

Side View

Unit: mm

Land Pattern Data

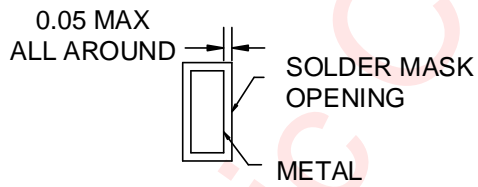
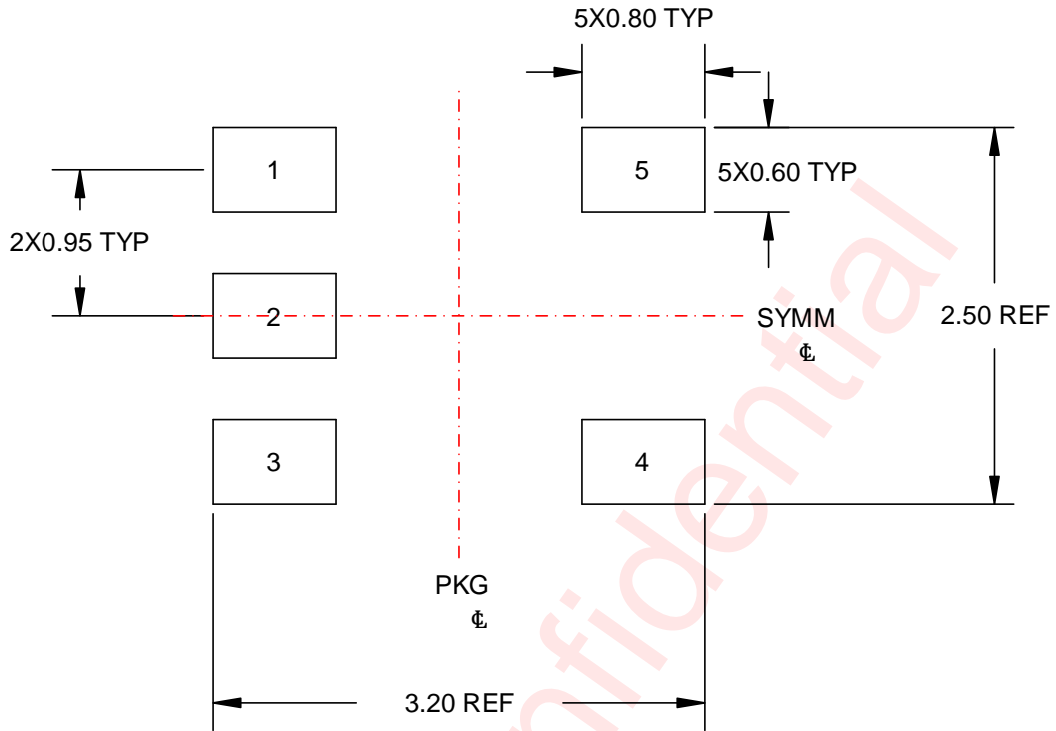

NON SOLDER MASK DEFINED

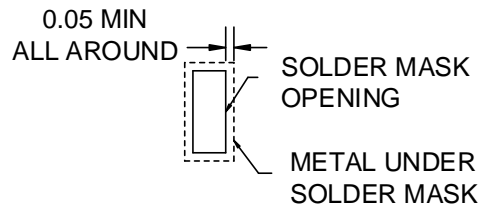

SOLDER MASK DEFINED

Unit: mm

Revision History

Version	Date	Change Record
V1.0	Nov. 2022	Datasheet V1.0 Released
V1.1	Feb. 2023	<ol style="list-style-type: none">1. Add the current limit response time t_{OCP} and the figure of t_{OCP}2. Modify the figure of UVLO vs. TEMP3. Modify the Pin Configuration And Top Mark4. Modify the D0 in Tape And Reel Information from 8.4mm to 8.5mm

awinic Confidential

Disclaimer

All trademarks are the property of their respective owners. Information in this document is believed to be accurate and reliable. However, Shanghai AWINIC Technology Co., Ltd (AWINIC Technology) does not give any representations or warranties, expressed or implied, as to the accuracy or completeness of such information and shall have no liability for the consequences of use of such information.

AWINIC Technology reserves the right to make changes to information published in this document, including without limitation specifications and product descriptions, at any time and without notice. Customers shall obtain the latest relevant information before placing orders and shall verify that such information is current and complete. This document supersedes and replaces all information supplied prior to the publication hereof.

AWINIC Technology products are not designed, authorized or warranted to be suitable for use in medical, military, aircraft, space or life support equipment, nor in applications where failure or malfunction of an AWINIC Technology product can reasonably be expected to result in personal injury, death or severe property or environmental damage. AWINIC Technology accepts no liability for inclusion and/or use of AWINIC Technology products in such equipment or applications and therefore such inclusion and/or use is at the customer's own risk.

Applications that are described herein for any of these products are for illustrative purposes only. AWINIC Technology makes no representation or warranty that such applications will be suitable for the specified use without further testing or modification.

All products are sold subject to the general terms and conditions of commercial sale supplied at the time of order acknowledgement.

Nothing in this document may be interpreted or construed as an offer to sell products that is open for acceptance or the grant, conveyance or implication of any license under any copyrights, patents or other industrial or intellectual property rights.

Reproduction of AWINIC information in AWINIC data books or data sheets is permissible only if reproduction is without alteration and is accompanied by all associated warranties, conditions, limitations, and notices. AWINIC is not responsible or liable for such altered documentation. Information of third parties may be subject to additional restrictions.

Resale of AWINIC components or services with statements different from or beyond the parameters stated by AWINIC for that component or service voids all express and any implied warranties for the associated AWINIC component or service and is an unfair and deceptive business practice. AWINIC is not responsible or liable for any such statements.