

BCD65N180P1

N-Channel Silicon Carbide Power MOSFET

650 V, 19 A, 180 mΩ



bestirpower

Features

- High Blocking Voltage with Low On-Resistance
- High Speed Switching with Low Capacitance
- Fast Intrinsic Diode With Low Reverse Recovery
- Low Switching Losses

BV_{DSS}	$I_D, T_C=25^\circ\text{C}$	$R_{DS(on),typ}$	$Q_{g,typ}$
650 V	19 A	180 mΩ	15.3 nC

Applications

- Switch Mode Power Supplies
- High Voltage DC/DC Converters
- Uninterruptable Power Supplies
- EV Battery Chargers
- Solar/Wind Inverters

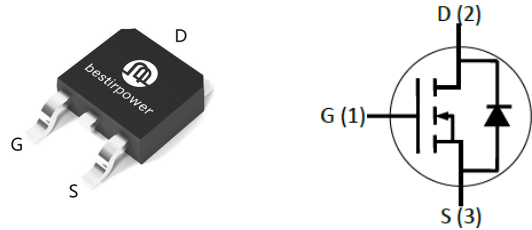

Absolute Maximum Ratings ($T_J = 25^\circ\text{C}$ unless otherwise noted)

Symbol	Parameter	Value	Unit	
V_{DSS}	Drain to Source Voltage	650	V	
V_{GS}	Gate to Source Voltage (DC)	-10 / +22	V	
V_{GSop}	Recommended Operation Value	0/15	V	
I_D	Drain Current	$V_{GS} = 15\text{ V}, (T_C = 25^\circ\text{C})$	19	A
		$V_{GS} = 15\text{ V}, (T_C = 100^\circ\text{C})$	13.5	
I_{DM}	Drain Current	Pulsed	33	A
P_D	Power Dissipation	($T_C = 25^\circ\text{C}$)	76	W
E_{AS}	Single Pulse Avalanche Energy	$V_{DD}=50\text{V}, V_{GS}=15\text{V}, L=0.5\text{mH}, I_{AS}=11.5\text{A}$	33.4	W/°C
T_J, T_{STG}	Operating and Storage Temperature Range	-55 to 175	°C	

Thermal Characteristics

Symbol	Parameter	Value	Unit
$R_{\theta JC}$	Thermal Resistance, Junction to Case, Max.	1.98	°C/W
T_{sold}	Soldering temperature, wave soldering only allowed at leads	260	°C

Electrical Characteristics ($T_J = 25^\circ\text{C}$ unless otherwise noted)

Symbol	Parameter	Test Conditions	Min	Typ	Max	Unit
--------	-----------	-----------------	-----	-----	-----	------

Off Characteristics

BV_{DSS}	Drain to Source Breakdown Voltage	$V_{GS} = 0\text{ V}, I_D = 100\ \mu\text{A}$	650	-	-	V
I_{DSS}	Zero Gate Voltage Drain Current	$V_{DS} = 650\text{ V}, V_{GS} = 0\text{ V}$	-	0.1	20	μA
I_{GSS}	Gate-Source Leakage Current	$V_{DS} = 0\text{ V}, V_{GS} = +22\text{ V}$	-	-	+250	nA
I_{GSS}	Source-Gate Leakage Current	$V_{DS} = 0\text{ V}, V_{GS} = -10\text{ V}$	-250	-	-	nA

On Characteristics

$V_{GS(th)}$	Gate Threshold Voltage	$V_{GS} = V_{DS}, I_{DS} = 10\text{ mA}, T_J = 25^\circ\text{C}$	-	3.9	-	V
$R_{DS(on)}$	Static Drain to Source On Resistance	$V_{GS} = 15\text{ V}, I_D = 7\text{ A}$	-	187	215	mΩ
		$V_{GS} = 15\text{ V}, I_D = 7\text{ A}, T_J = 175^\circ\text{C}$	-	175	-	

Dynamic Characteristics

C_{iss}	Input Capacitance	$V_{GS} = 0\text{ V}, V_{DS} = 650\text{ V}, f = 1\text{ MHz}$	-	431	-	pF
C_{oss}	Output Capacitance		-	30	-	
C_{riss}	Reverse Capacitance		-	3	-	
$Q_{g(tot)}$	Total Gate Charge	$V_{DS} = 400\text{ V}, I_D = 7\text{ A}, V_{GS} = 0\text{ V} / 15\text{ V}$	-	15.3	-	nC
Q_{gs}	Gate to Source Charge		-	5.5	-	
Q_{gd}	Gate to Drain "Miller" Charge		-	2.6	-	
R_G	Internal Gate Resistance	$f = 1\text{ MHz}, V_{AC} = 25\text{ mV}$	-	36	-	Ω



Switching Characteristics

$t_{d(on)}$	Turn-On Delay Time	$V_{GS} = 0/15\text{ V}, L = 600\ \mu\text{H}, V_{DS} = 400\text{ V}, I_D = 7\text{ A}, R_{G(on)} = 2.2\ \Omega, R_{G(off)} = 2.2\ \Omega$	-	27.6	-	ns
t_r	Turn-On Rise Time		-	10.8	-	
$t_{d(off)}$	Turn-Off Delay Time		-	43.1	-	
t_f	Turn-Off Fall Time		-	13.3	-	μJ
E_{on}	Turn-On Switching Energy		-	67.5	-	
E_{off}	Turn-Off Switching Energy		-	10.5	-	

Source-Drain Diode Characteristics

I_S	Continuous Diode Forward Current	$T_C = 25^\circ\text{C}$	-	13.5	-	A
		$T_C = 100^\circ\text{C}$	-	7.7	-	
V_{SD}	Diode Forward Voltage	$V_{GS} = 0\text{ V}, I_{SD} = 3.5\text{ A}$	-	3.3	-	V
t_{rr}	Reverse Recovery Time	$V_{DS} = 400\text{ V}, V_{GS} = 0\text{ V}, I_{SD} = 7\text{ A}, di/dt = 2000\text{ A}/\mu\text{s}$	-	26	-	ns
Q_{rr}	Reverse Recovery Charge		-	68	-	nC
I_{rrm}	Peak Reverse Recovery Current		-	5.8	-	A

Typical Performance Characteristics

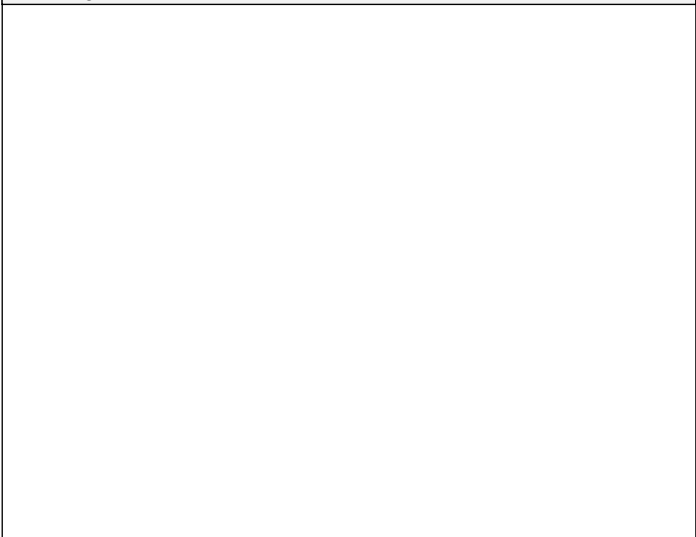
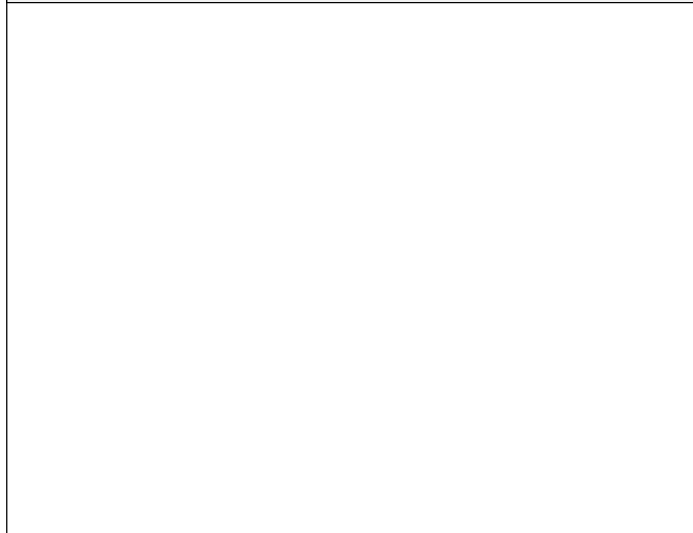
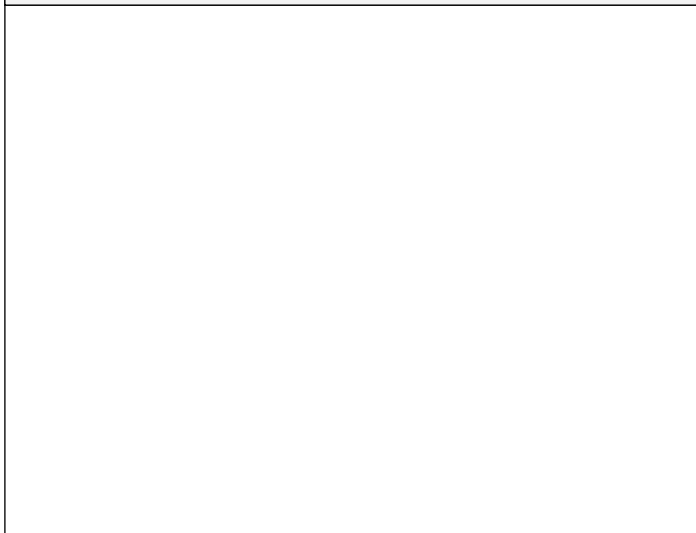
<p>Figure 1: Safe Operating Area ($R_{thjc}=2.37\text{ }^{\circ}\text{C/W}$, Single Pulse, $T_{vj}=25\text{ }^{\circ}\text{C}$)</p> 	<p>Figure 2: Power Dissipation as a Function of Case Temperature Limited by Bond Wire</p> 
<p>Figure 3 Typical Output Characteristic, VGS as Parameter $T_v=-55\text{ }^{\circ}\text{C}$</p> 	<p>Figure 4 Typical Output Characteristic, VGS as Parameter $T_v=25\text{ }^{\circ}\text{C}$</p> 
<p>Figure 5 Typical Output Characteristic, VGS as Parameter $T_v=175\text{ }^{\circ}\text{C}$</p> 	<p>Figure 6: Typical on-state Resistance as a Function of Drain Current (VGS=15V)</p> 

Typical Performance Characteristics

Figure 7: Typical on-state Resistance as a Function of Temperature (IDS=7A)

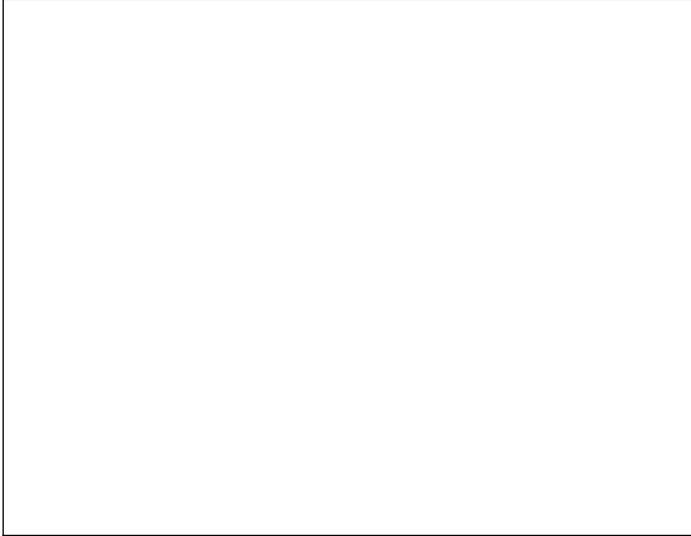

Figure 8: Typical on-state Resistance as a Function of VGS (IDS=7A)



Figure 9: Typical Transfer Characteristic (VDS=20V)

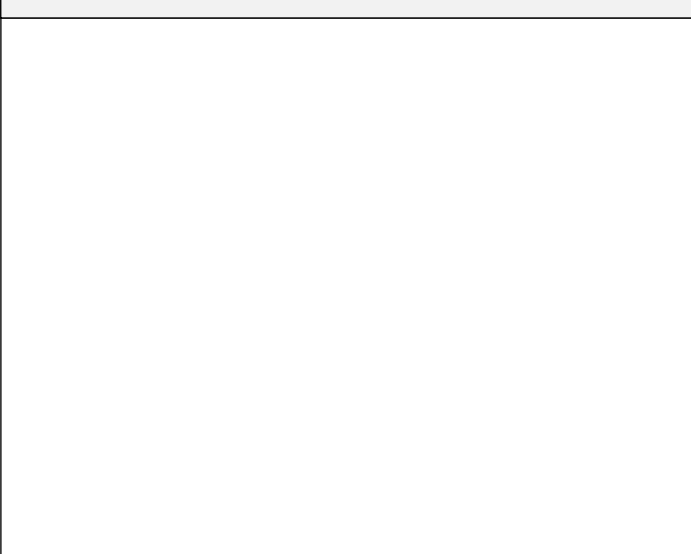

Figure 10: Threshold Voltage vs Temperature (IDS=10mA)

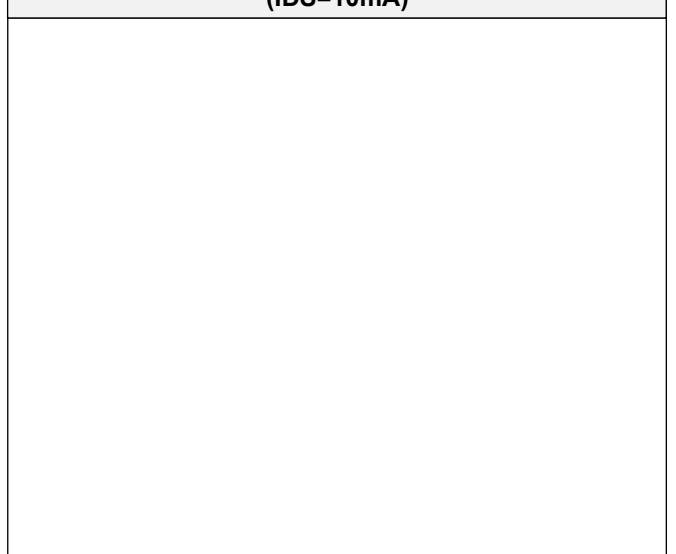
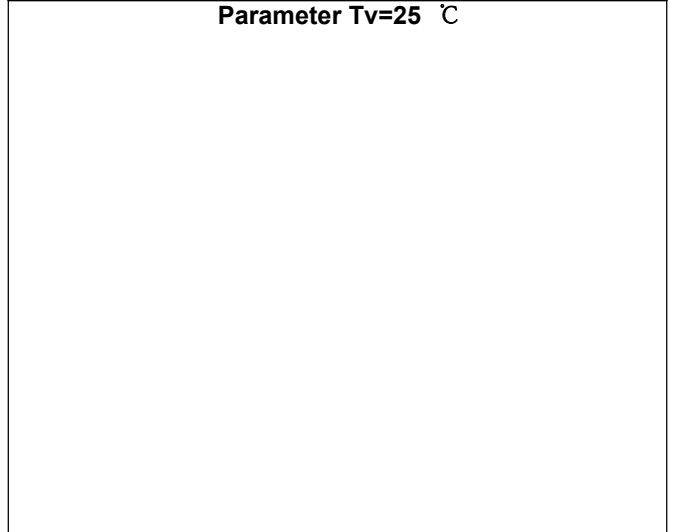

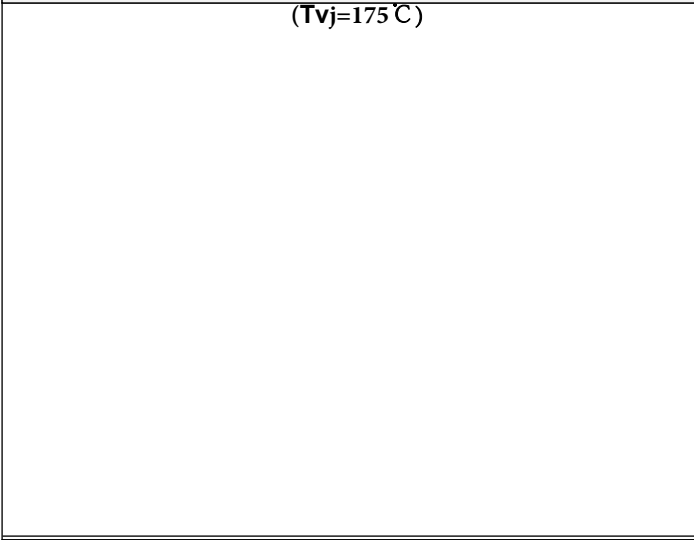
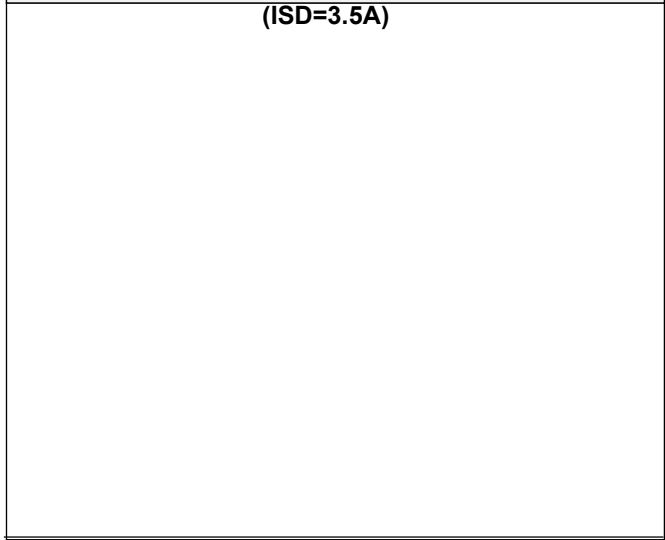

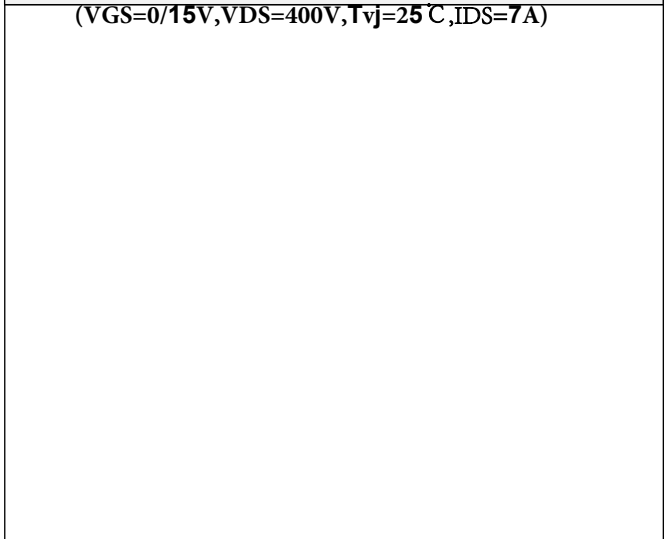
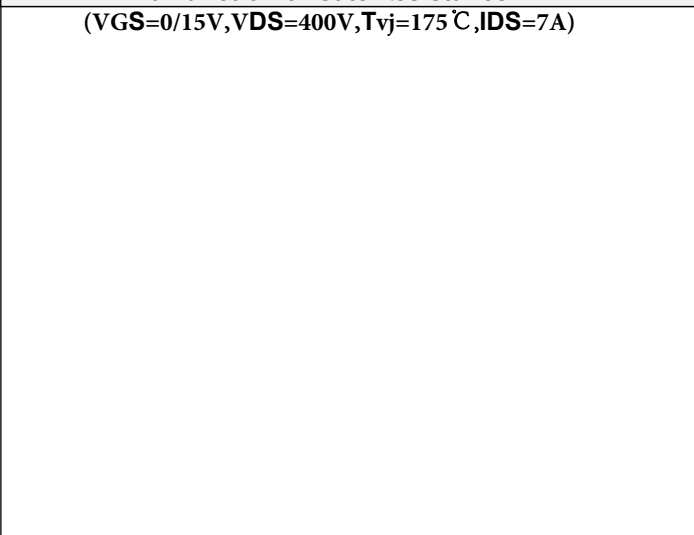

Figure 11 Typical Reverse Drain Current as Function of Reverse Drain Voltage, VGS as Parameter Tv=-55 °C



Figure 12 Typical Reverse Drain Current as Function of Reverse Drain Voltage, VGS as Parameter Tv=25 °C



Typical Performance Characteristics

<p>Figure 13: Typical Reverse Drain Current as Function of Reverse Drain Voltage, VGS as Parameter ($T_{vj}=175^{\circ}\text{C}$)</p> 	<p>Figure 14: Typical Reverse Drain Voltage as Function of Junction Temperature ($I_{SD}=3.5\text{A}$)</p> 
<p>Figure 15: Typical Switching Energy as a Function of Junction Temperature ($V_{GS}=0/15\text{V}, V_{DS}=400\text{V}, R_{G(\text{ext})}=2.2\Omega, I_{DS}=7\text{A}$)</p> 	<p>Figure 16: Typical Switching Energy as a Function of Junction Temperature ($V_{GS}=0/15\text{V}, V_{DS}=400\text{V}, T_{vj}=25^{\circ}\text{C}, I_{DS}=7\text{A}$)</p> 
<p>Figure 17: Typical Switching Energy Losses as a Function of Gate Resistance ($V_{GS}=0/15\text{V}, V_{DS}=400\text{V}, T_{vj}=175^{\circ}\text{C}, I_{DS}=7\text{A}$)</p> 	<p>Figure 18: Typical Switching Energy Losses as a Function of IDS ($V_{GS}=0/15\text{V}, V_{DS}=400\text{V}, R_{G(\text{ext})}=2.2\Omega, T_{vj}=25^{\circ}\text{C}$)</p> 

Typical Performance Characteristics

<p>Figure 19: Typical Switching Energy Losses as a Function of I_{DS} ($V_{GS}=0/15V, V_{DS}=400V, T_{vj}=175\text{ }^{\circ}\text{C}, R_{G(ext)}=2.2\Omega$)</p>	<p>Figure 20: Typical switching energy losses as a function of V_{DS} ($V_{GS}=0/15V, T_{vj}=25\text{ }^{\circ}\text{C}, R_{G(ext)}=2.2\Omega, I_{DS}=7A$)</p>
<p>Figure 21: Typical Switching Energy Losses as a Function of V_{DS} ($V_{GS}=0/15V, T_{vj}=175\text{ }^{\circ}\text{C}, R_{G(ext)}=2.2\Omega, I_{DS}=7A$)</p>	<p>Figure 22: Typical Gate Charge ($V_{DS}=400V, I_{DS}=7A$)</p>
<p>Figure 23: Typical Capacitance as a Function of Drain-Source Voltage ($V_{GS}=0V, f=1\text{MHz}$)</p>	<p>Figure 24: Transient thermal resistance (MOSFET)</p>

Package Outlines

D-Pak

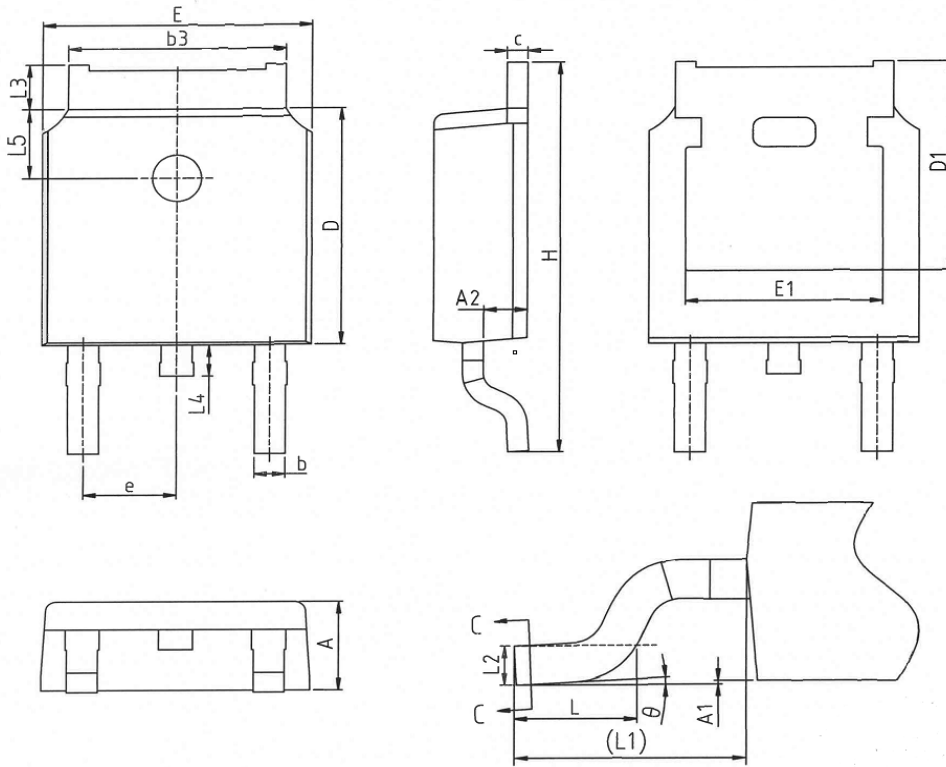

COMMON DIMENSIONS

SYMBOL	mm		
	MIN	NOM	MAX
A	2.20	2.30	2.38
A1	0.00	-	0.12
A2	0.97	1.07	1.17
b	0.68	0.78	0.90
b3	5.20	5.33	5.46
c	0.43	0.53	0.61
D	5.98	6.10	6.22
D1	5.30REF		
E	6.40	6.60	6.73
E1	4.63	-	-
e	2.286BSC		
H	9.40	10.10	10.50
L	1.38	1.50	1.75
L1	2.90REF		
L2	0.51BSC		
L3	0.88	-	1.28
L4	0.50	-	1.00
L5	1.65	1.80	1.95
θ	0°	-	8°

* Dimensions in millimeters

Package Marking and Ordering Information

Part Number	Top Marking	Package	Packing Method	Quantity
BCD65N180P1	BCD65N180P1	DPAK	Tape & Reel	2500 units

Disclaimer

Bestirpower reserve the right to make changes, corrections, enhancements, modifications, and improvements to Bestirpower products and/or to this document at any time without notice.

The information given in this document shall in no event be regarded as a guarantee of conditions or characteristics. Bestirpower does not assume any liability for infringement of patents, copyrights, or other intellectual property rights of third parties by or arising from the use of Products or technical information described in this document.

This document is the property of Bestirpower Co., LTD., and not allowed to copy or transformed to other format if not under the authority approval.

© 2026 Bestirpower – All rights reserved