

BCD80N380W1

N-Channel Silicon Carbide Power MOSFET

800 V, 10 A, 380 mΩ



bestirpower

Features

- High Blocking Voltage with Low On-Resistance
- High Speed Switching with Low Capacitances
- Easy to Parallel and Simple to Drive
- Avalanche Ruggedness
- Halogen Free, RoHS Compliant

$BV_{DSS, T_C=25^\circ C}$	$I_D, T_C=25^\circ C$	$R_{DS(on), typ}$	$Q_{g, typ}$
800 V	10 A	380 mΩ	10.6 nC

Benefits

- Higher System Efficiency
- Reduced Cooling Requirements
- Increased Power Density
- Increased System Switching Frequency

Applications

- Solar Inverters
- Switch Mode Power Supplies
- High Voltage DC/DC Converters
- Battery Chargers
- Motor Drives
- Pulsed Power applications

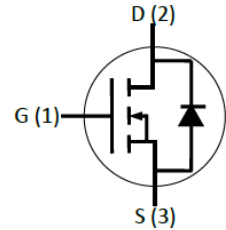
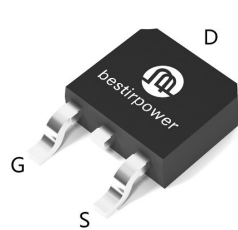

Absolute Maximum Ratings ($T_J = 25^\circ C$ unless otherwise noted)

Symbol	Parameter	Value	Unit	
V_{DSS}	Drain to Source Voltage	800	V	
V_{GS}	Gate to Source Voltage (DC)	-10 / +22	V	
V_{GSop}	Recommended Operation Value	-5 / +18	V	
I_D	Drain Current	$V_{GS} = 18 V, (T_C = 25^\circ C)$	10	A
		$V_{GS} = 18 V, (T_C = 100^\circ C)$	7	
I_{DM}	Drain Current	Pulsed (Note1)	22	A
P_D	Power Dissipation	$(T_C = 25^\circ C)$	54.7	W
		Derate Above 25°C	0.36	W/°C
T_J, T_{STG}	Operating and Storage Temperature Range	-55 to 175	°C	

※Note 1 : Limited by maximum junction temperature.

Thermal Characteristics

Symbol	Parameter	Value	Unit
$R_{\theta JC}$	Thermal Resistance, Junction to Case, Max.	2.74	°C/W
$R_{\theta JA}$	Thermal Resistance, Junction to Ambient, Max.	48	
T_{sold}	Soldering temperature, wave soldering only allowed at leads	260	°C

Electrical Characteristics ($T_J = 25^\circ\text{C}$ unless otherwise noted)

Symbol	Parameter	Test Conditions	Min	Typ	Max	Unit
--------	-----------	-----------------	-----	-----	-----	------

Off Characteristics

BV_{DSS}	Drain to Source Breakdown Voltage	$V_{GS} = 0\text{ V}, I_D = 100\ \mu\text{A}$	800	-	-	V
I_{DSS}	Zero Gate Voltage Drain Current	$V_{DS} = 650\text{ V}, V_{GS} = 0\text{ V}$	-	2	10	μA
I_{GSS}	Gate-Source Leakage Current	$V_{DS} = 0\text{ V}, V_{GS} = +22\text{ V}$	-	-	+200	nA
		$V_{DS} = 0\text{ V}, V_{GS} = -10\text{ V}$	-200	-	-	nA

On Characteristics

$V_{GS(th)}$	Gate Threshold Voltage	$V_{GS} = V_{DS}, I_{DS} = 1\text{ mA}, T_J = 25^\circ\text{C}$	2.2	3.4	4.2	V
$R_{DS(on)}$	Static Drain to Source On Resistance	$V_{GS} = 18\text{ V}, I_D = 5\text{ A}$	-	380	450	mΩ
		$V_{GS} = 18\text{ V}, I_D = 5\text{ A}, T_J = 175^\circ\text{C}$	-	520	-	

Dynamic Characteristics

C_{iss}	Input Capacitance	$V_{DS} = 400\text{ V}, V_{GS} = 0\text{ V}, f = 1\text{ MHz}$	-	208	-	pF
C_{oss}	Output Capacitance		-	18	-	
C_{rss}	Reverse Capacitance		-	1.8	-	
$Q_{g(tot)}$	Total Gate Charge	$V_{DS} = 400\text{ V}, I_D = 5\text{ A}, V_{GS} = -5\text{ V} / 18\text{ V}$	-	10.6	-	nC
Q_{gs}	Gate to Source Charge		-	5.1	-	
Q_{gd}	Gate to Drain "Miller" Charge		-	2.2	-	
R_G	Internal Gate Resistance	$f = 1\text{ MHz}$	-	59	-	Ω

Switching Characteristics

$t_{d(on)}$	Turn-On Delay Time	$V_{DS} = 400\text{ V}, I_D = 5\text{ A}, V_{GS} = -5\text{ V} / 18\text{ V}, R_G = 10\ \Omega,$	-	5	-	ns
t_r	Turn-On Rise Time		-	17	-	
$t_{d(off)}$	Turn-Off Delay Time		-	8	-	
t_f	Turn-Off Fall Time		-	10	-	
E_{on}	Turn-On Switching Energy		$V_{DD} = 400\text{ V}, I_D = 5\text{ A}, V_{GS} = -5/18\text{ V}, R_G = 10\ \Omega$	-	25	-
E_{off}	Turn-Off Switching Energy	-		10	-	

Source-Drain Diode Characteristics

I_{SD}	Continuous Diode Forward Current	$T_C = 25^\circ\text{C}$	-	9	-	A
		$T_C = 100^\circ\text{C}$	-	6	-	
V_{SD}	Diode Forward Voltage	$V_{GS} = -5\text{ V}, I_{SD} = 2.5\text{ A}$	-	4.0	-	V
t_{rr}	Reverse Recovery Time	$I_{SD} = 5\text{ A}, di/dt = 1000\text{ A}/\mu\text{s}, V_{DD} = 400\text{ V}, V_{GS} = -5\text{ V}$	-	23	-	ns
Q_{rr}	Reverse Recovery Charge		-	32	-	nC
I_{rrm}	Peak Reverse Recovery Current		-	2.4	-	A

Typical Performance Characteristics

Figure 1. Typical Output Characteristics, $T_J = 25^\circ\text{C}$

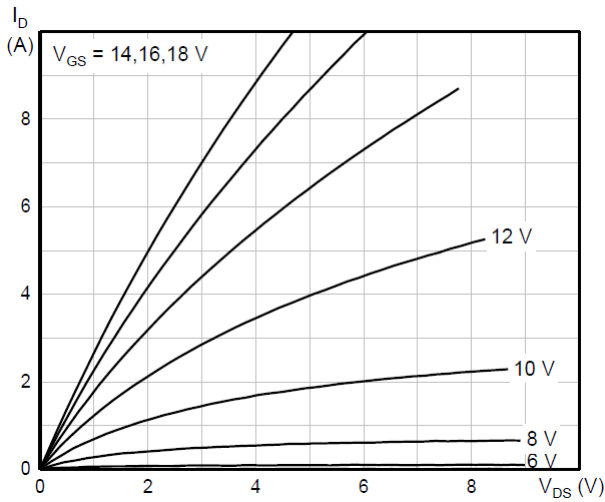

Figure 2. Typical Output Characteristics, $T_J = 175^\circ\text{C}$

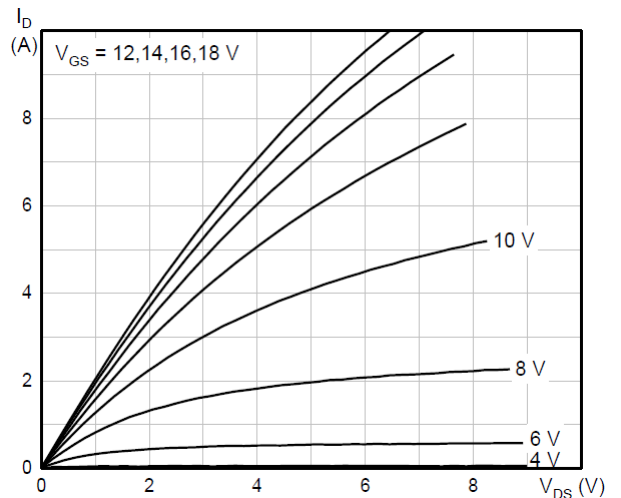

Figure 3. Typical Transfer Characteristics

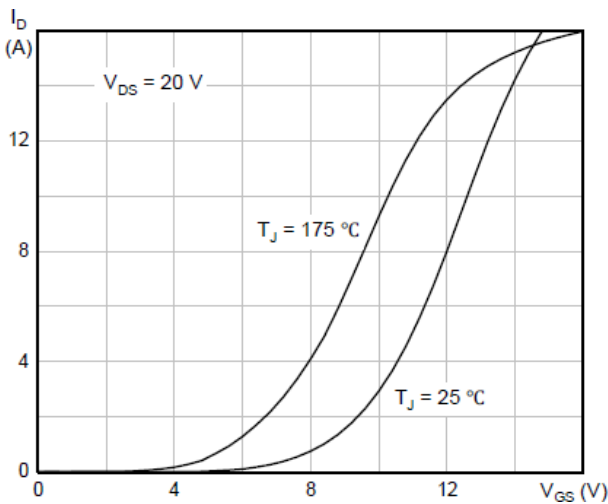

Figure 4. Typical Gate Charge Characteristics

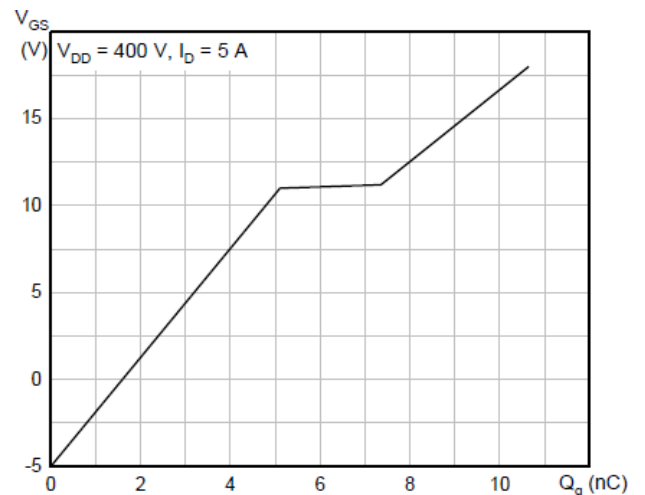

Figure 5. Typical Capacitance Characteristics

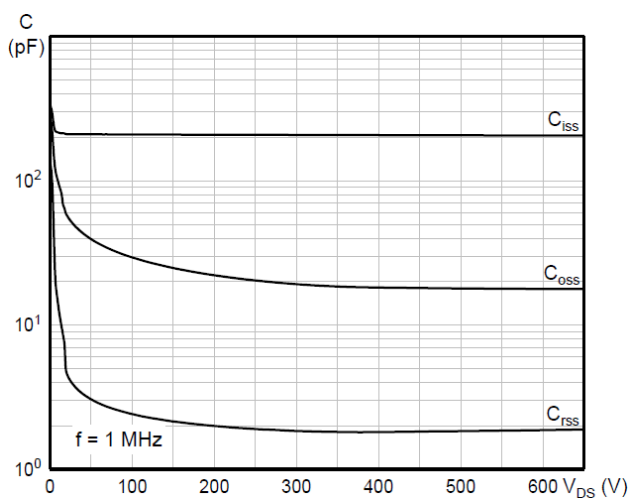
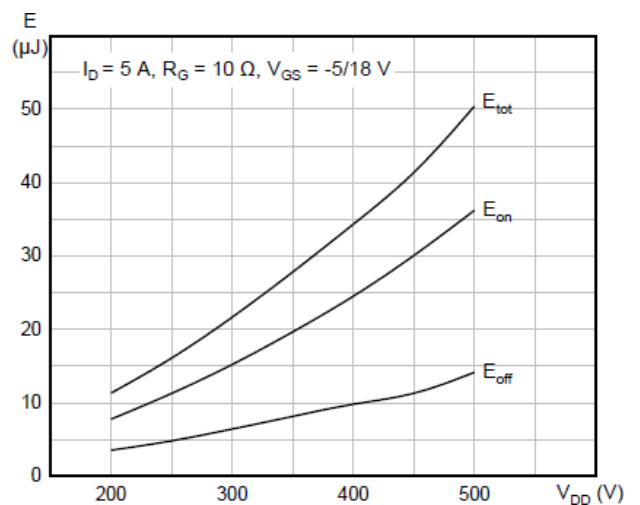

Figure 6. Typical Switching Energy vs. Supply Voltage



Typical Performance Characteristics

Figure 7. Typical Switching Energy vs. Drain Current

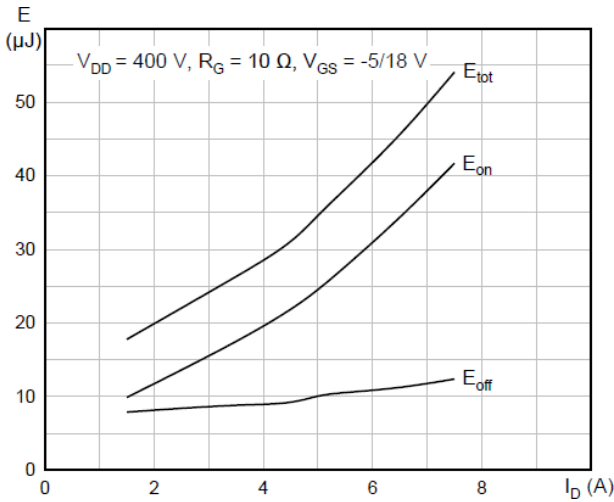

Figure 8. Typical Switching Energy vs. Gate Resistance

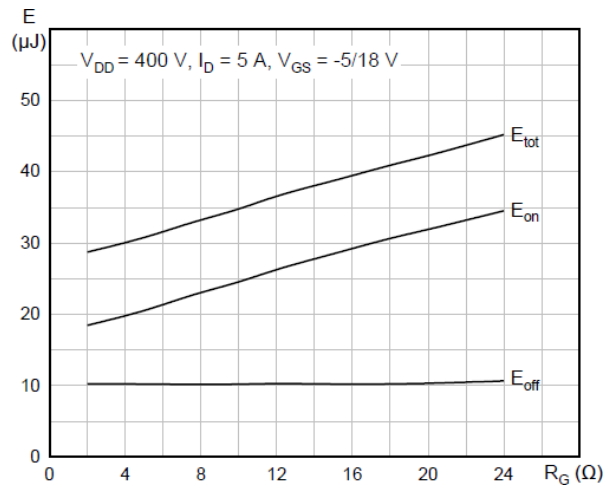

Figure 9. Typical Switching Energy vs. Temperature

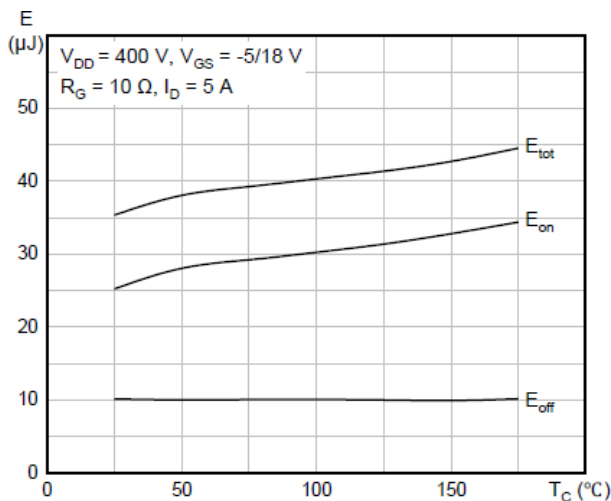

Figure 10. Breakdown Voltage vs. Temperature

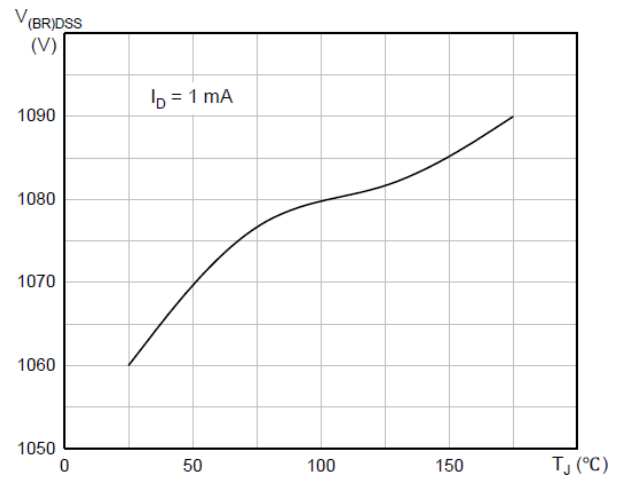

Figure 11. Gate Threshold vs. Temperature

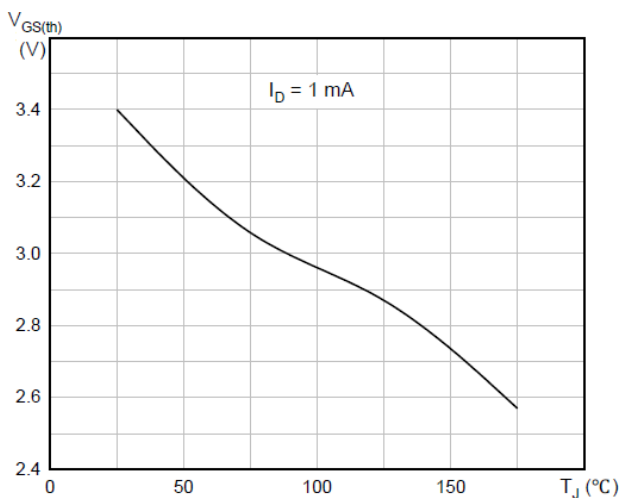
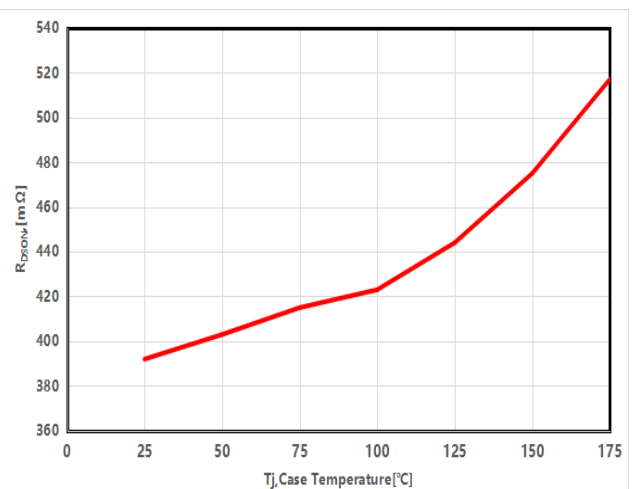

Figure 12. On-Resistance vs. Temperature



Typical Performance Characteristics

Figure 13. Body Diode Characteristics, $T_J = 25^\circ\text{C}$

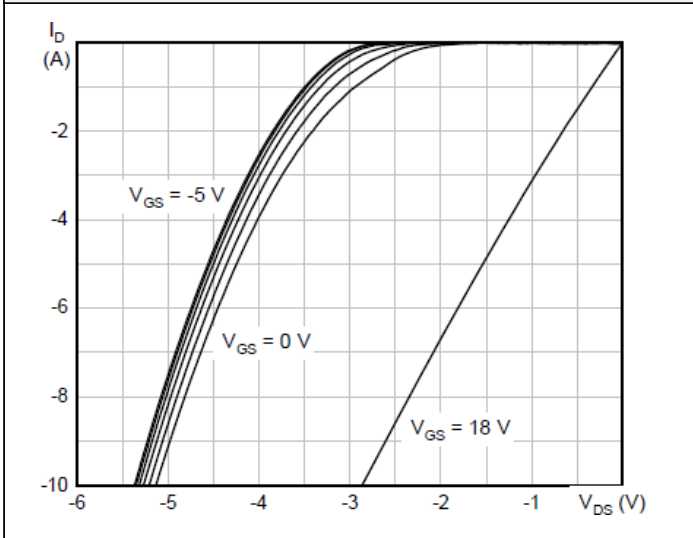

Figure 14. Body Diode Characteristics, $T_J = 175^\circ\text{C}$

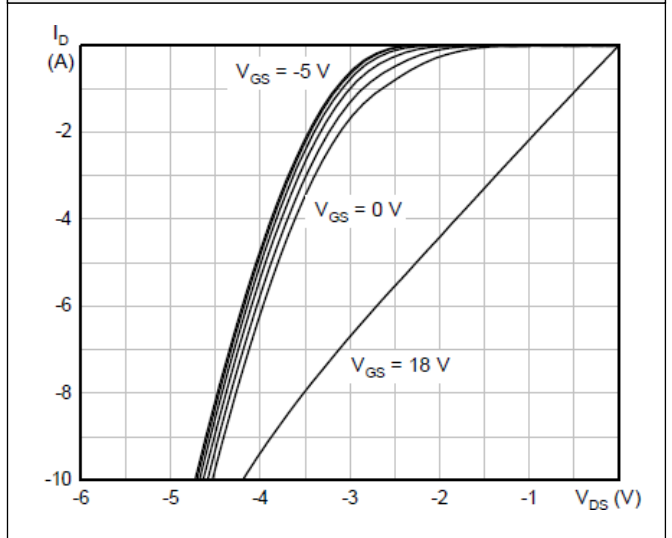

Figure 15. Continuous Drain Current Derating vs. Case Temperature

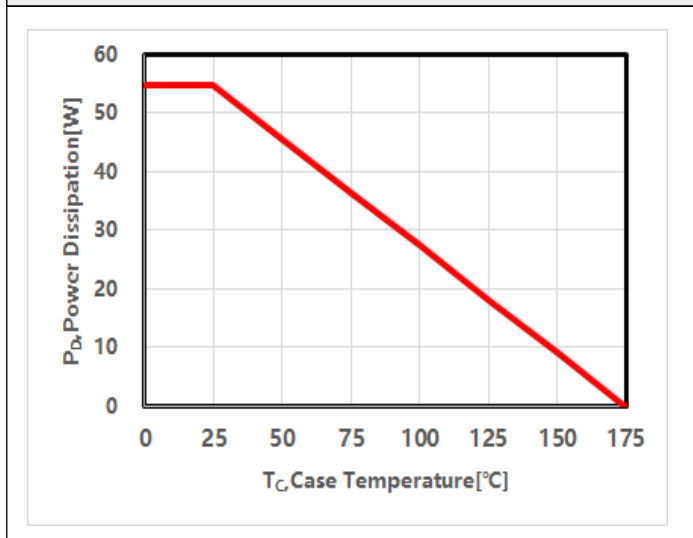

Figure 16. Maximum Power Dissipation Derating vs. Case Temperature

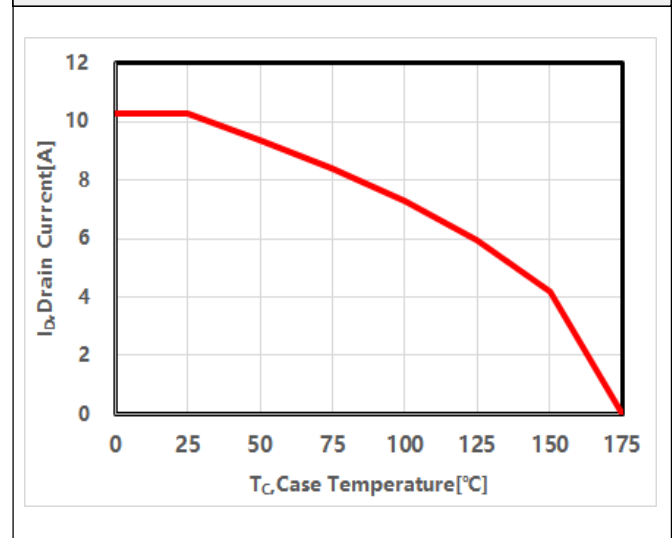

Figure 17. Maximum Safe Operating Area

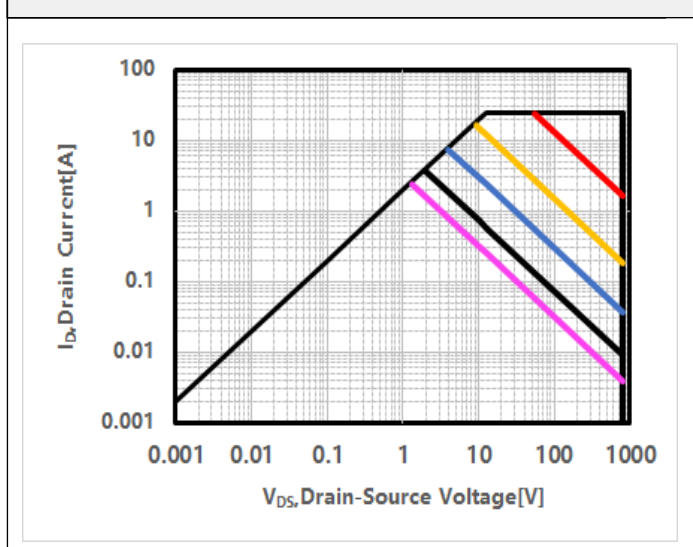
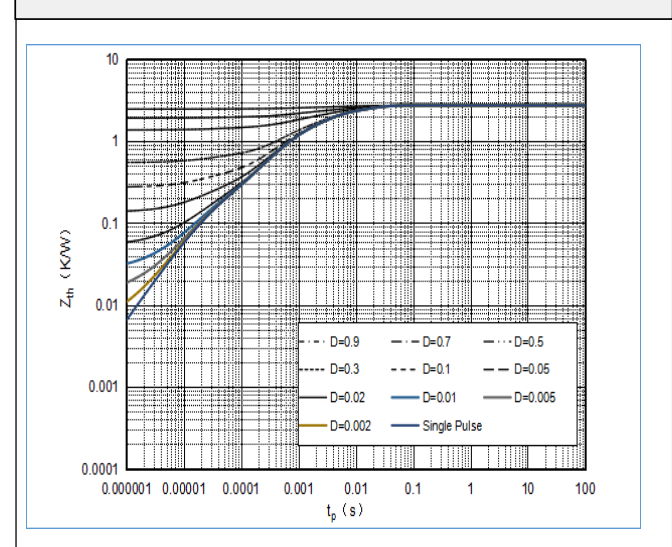
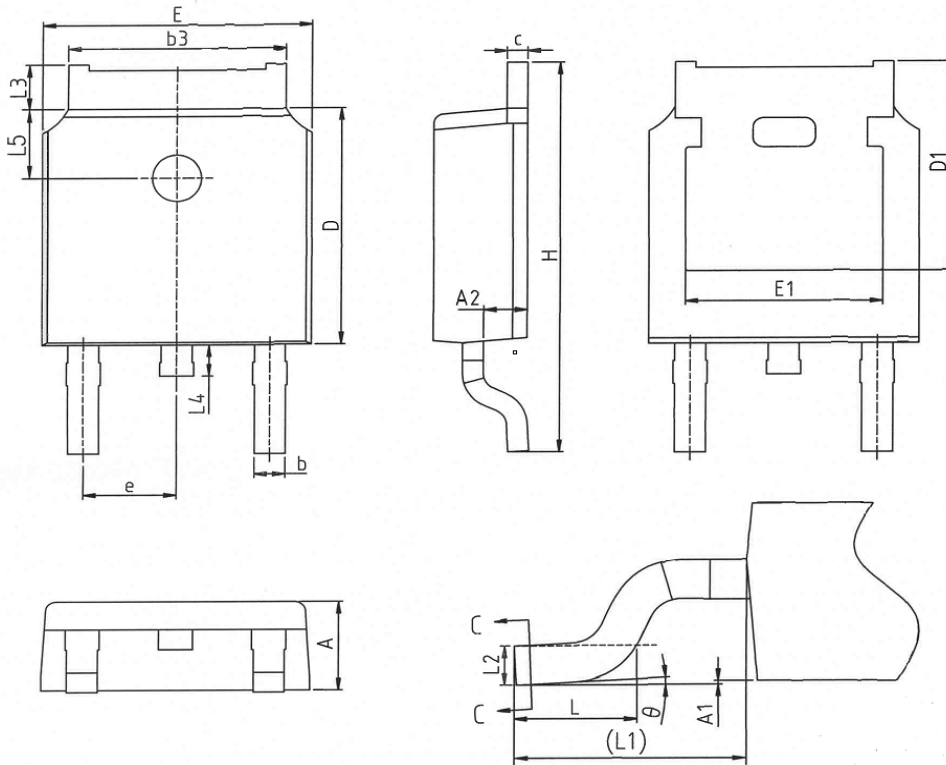

Figure 18. Transient Thermal Response Curve



Package Outlines

D-Pak



COMMON DIMENSIONS

SYMBOL	mm		
	MIN	NOM	MAX
A	2.20	2.30	2.38
A1	0.00	-	0.12
A2	0.97	1.07	1.17
b	0.68	0.78	0.90
b3	5.20	5.33	5.46
c	0.43	0.53	0.61
D	5.98	6.10	6.22
D1	5.30REF		
E	6.40	6.60	6.73
E1	4.63	-	-
e	2.286BSC		
H	9.40	10.10	10.50
L	1.38	1.50	1.75
L1	2.90REF		
L2	0.51BSC		
L3	0.88	-	1.28
L4	0.50	-	1.00
L5	1.65	1.80	1.95
θ	0°	-	8°

* Dimensions in millimeters

Package Marking and Ordering Information

Part Number	Top Marking	Package	Packing Method	Quantity
BCD80N380W1	BCD80N380W1	DPAK	Tape & Reel	2500 units

Disclaimer

Bestirpower reserve the right to make changes, corrections, enhancements, modifications, and improvements to Bestirpower products and/or to this document at any time without notice.

The information given in this document shall in no event be regarded as a guarantee of conditions or characteristics. Bestirpower does not assume any liability for infringement of patents, copyrights, or other intellectual property rights of third parties by or arising from the use of Products or technical information described in this document.

This document is the property of Bestirpower Co., LTD., and not allowed to copy or transformed to other format if not under the authority approval.

© 2026 Bestirpower – All rights reserved