

20VV6 ! PENDING OBSOLESCENCE

Corcom | Corcom V

TE Internal #: 6609043-5

TE Internal Description: 20VV6=F7771 S0

Single Phase Filters, Corcom V Series

[View on TE.com >](#)



EMI & EMC Solutions > EMI Filters > Power Line Filters > Single Phase Filters > Single Phase Filters, Corcom V Series

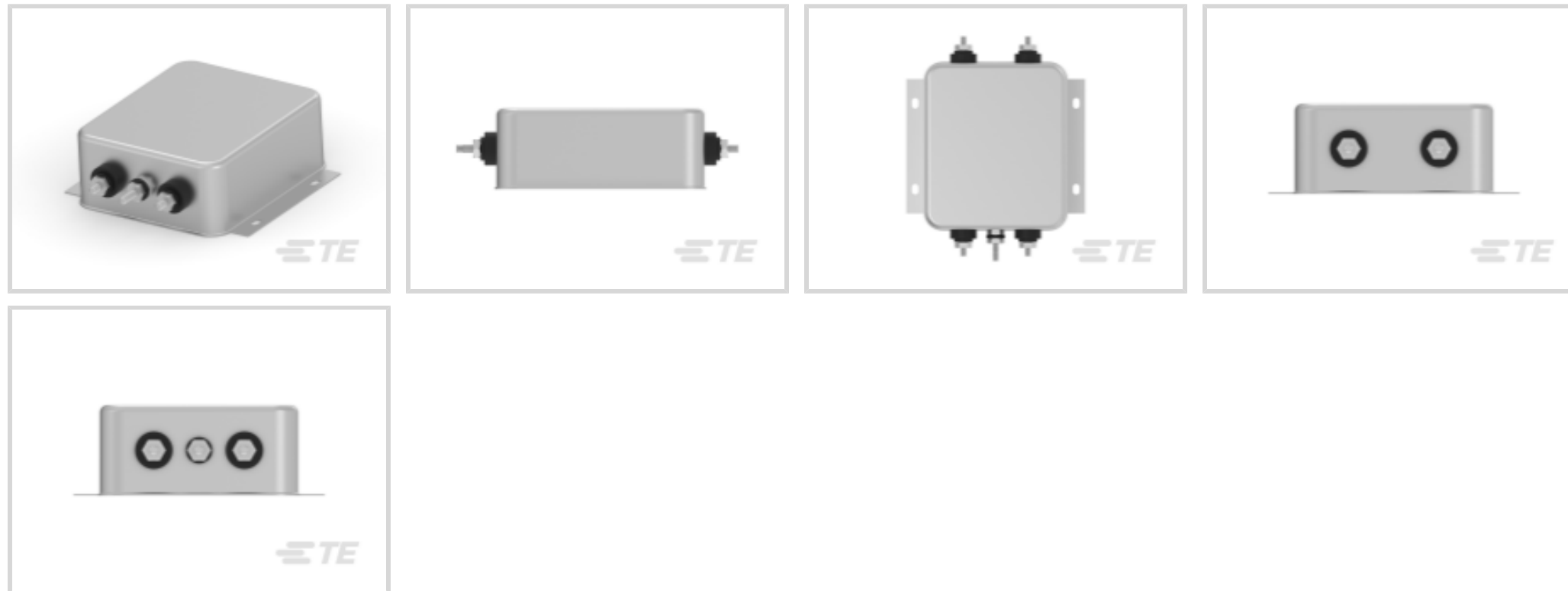

Current Rating: 20 A

Input Termination Type: Stud

Output Termination Type: Stud

Leakage Current (Max) (120VAC, 60Hz): .5 mA

Leakage Current (Max) (250VAC, 50Hz): .82 mA

[All Single Phase Filters, Corcom V Series \(0\)](#)

Features

Product Type Features

Ground Choke Option	No
Filtering Requirements	Filtered
Input Termination Type	Stud
Output Termination Type	Stud

Electrical Characteristics

Operating Voltage	250 VAC
Current Rating	20 A
Leakage Current (Max) (120VAC, 60Hz)	.5 mA
Leakage Current (Max) (250VAC, 50Hz)	.82 mA

Mechanical Attachment

Panel Mount Feature Type	Flanged
--------------------------	---------

Usage Conditions

Operating Temperature Range	-10 – 40 °C
-----------------------------	-------------

Product Compliance

[For compliance documentation, visit the product page on TE.com>](#)

EU RoHS Directive 2011/65/EU	Compliant
EU ELV Directive 2000/53/EC	Compliant
China RoHS 2 Directive MIIT Order No 32, 2016	No Restricted Materials Above Threshold
EU REACH Regulation (EC) No. 1907/2006	Current ECHA Candidate List: JUNE 2024 (241) Candidate List Declared Against: JUNE 2024 (241) Does not contain REACH SVHC
Halogen Content	Not Low Halogen - contains Br or Cl > 900 ppm.
Solder Process Capability	Not applicable for solder process capability

Product Compliance Disclaimer

This information is provided based on reasonable inquiry of our suppliers and represents our current actual knowledge based on the information they provided. This information is subject to change. The part numbers that TE has identified as EU RoHS compliant have a maximum concentration of 0.1% by weight in homogenous materials for lead, hexavalent chromium, mercury, PBB, PBDE, DBP, BBP, DEHP, DIBP, and 0.01% for cadmium, or qualify for an exemption to these limits as defined in the Annexes of Directive 2011/65/EU (RoHS2). Finished electrical and electronic equipment products will be CE marked as required by Directive 2011/65/EU. Components may not be CE marked. Additionally, the part numbers that TE has identified as EU ELV compliant have a maximum concentration of 0.1% by weight in homogenous materials for lead, hexavalent chromium, and mercury, and 0.01% for cadmium, or qualify for an exemption to these limits as defined in the Annexes of Directive 2000/53/EC (ELV). Regarding the REACH Regulation, the information TE provides on SVHC in articles for this part number is based on the latest European Chemicals Agency (ECHA) 'Guidance on requirements for substances in articles' posted at this URL: <https://echa.europa.eu/guidance-documents/guidance-on-reach>

Compatible Parts



Also in the Series |

Customers Also Bought

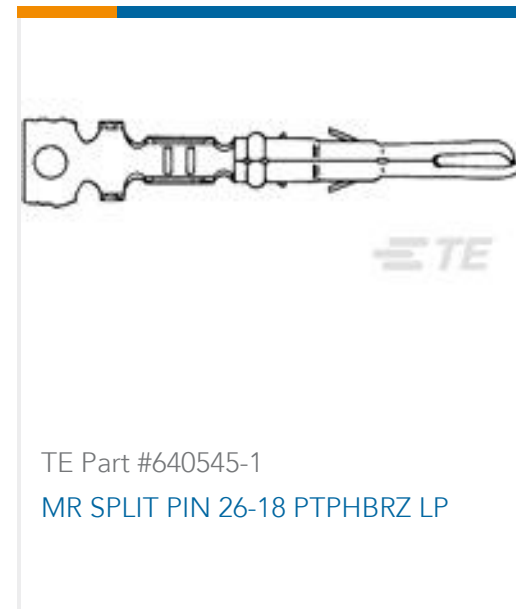
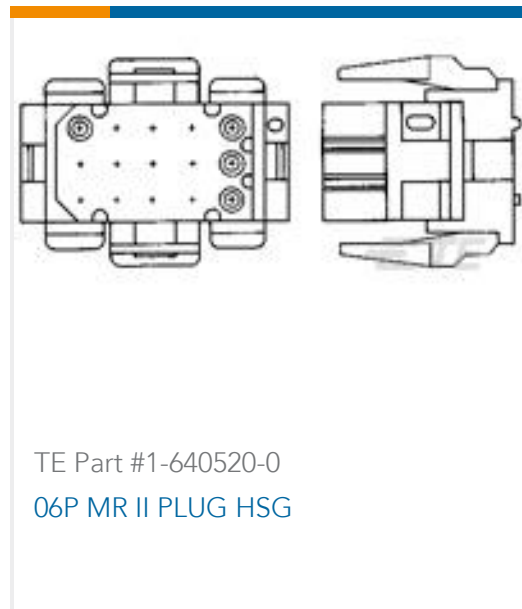
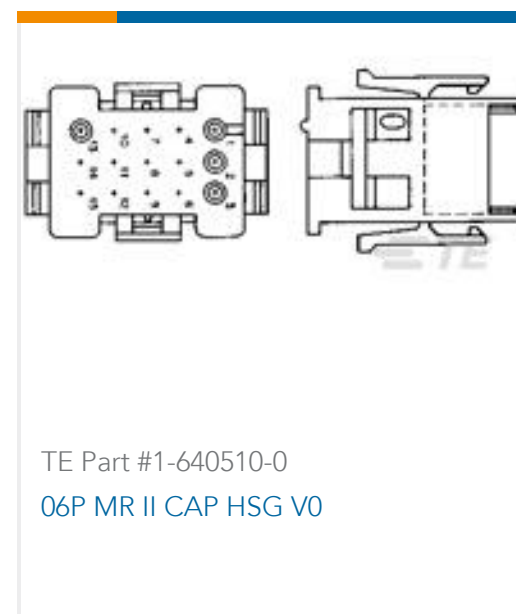

Documents

CAD Files

Customer View Model

[ENG_CVM_CVM_6609043-5_B1.3d_igs.zip](#)

English

Customer View Model

[ENG_CVM_CVM_6609043-5_B1.3d_stp.zip](#)

English

Customer View Model

[ENG_CVM_CVM_6609043-5_B1.2d_dxf.zip](#)

English

3D PDF

3D

By downloading the CAD file I accept and agree to the [Terms and Conditions](#) of use.

Datasheets & Catalog Pages

[1654001_CORCOM_PRODUCT_GUIDE_V_W_SERIES](#)

English

Corcom Combined Selector Charts

English

[1-1654250-1_CORCOM_EMI_RFI_QRG](#)

English