

PTH05030

5 Vin Single Output

Data Sheet

Total Power: 108 Watts
of Outputs: Single

SPECIAL FEATURES

- 30 A output current
- 5 V input voltage
- Wide-output voltage adjust (0.8 V - 3.6 V)
- Auto-track™ sequencing*
- Margin up/down controls
- Pre-bias start-up capability
- Efficiencies up to 94%
- Output ON/OFF inhibit
- Output voltage sense
- Point-of-Load-Alliance (POLA) compatible
- RoHS compliant
- Two year warranty

SAFETY

- UL/cUL CAN/CSA-C22.2 No. 60950-1-03/UL 60950-1, File No. E174104
- TÜV Product Service (EN60950) Certificate No. B04 06 38572 044
- CB report and certificate to IEC60950, Certificate No. US/8292/UL



Electrical Specifications

Input		
Input voltage range	(See Note 3)	4.5 - 5.5 Vdc
Input current	No load	10 mA typical
Remote ON/OFF	(See Note 1)	Positive logic
Start-up time		1 V/ms
Undervoltage lockout		3 - 4.35 Vdc typical
Track input voltage	Pin 11 (See Notes 6 & 7)	±0.3 Vin
Output		
Voltage adjustability	(See Note 4)	0.8 - 3.6 Vdc
Setpoint accuracy		±2.0% Vo
Line regulation		±10 mV typical
Load regulation		±12 mV typical
Total regulation		±3.0% Vo
Minimum load		0 A
Ripple and noise	20 MHz bandwidth	40 mV pk-pk
Temperature co-efficient	-40 °C to +85 °C	±0.5% Vo
Transient response	(See Note 5)	70 µs recovery time Overshoot/undershoot 100 mV
Margin adjustment		±5.0% Vo

All specifications are typical at nominal input, full load at 25 °C unless otherwise stated.
 Cin = 1500 µF, Cout = 0 µF.

*Auto-track is a trademark of Texas Instruments.

General Specifications

Efficiency	(See Efficiency Table)	94% max.
Insulation voltage		Non-isolated
Switching frequency		275 - 325 kHz
Approvals and standards		EN60950, UL/cUL60950
Material flammability		UL94V-0
Dimensions	L x W x H	34.80 x 28.45 x 9.00 mm 1.370 x 1.120 x 0.354 in
Weight		10 g (.35 oz)
MTBF	Telcordia SR-332	2,821,000 hours

EMC Characteristics

Electrostatic discharge	EN61000-4-2, IEC801-2
Conducted immunity	EN61000-4-6
Radiated immunity	EN61000-4-3

Environmental Specifications

Thermal performance (See Note 2)	Operating ambient temperature	-40 °C to +85 °C
	Non-operating temperature	-40 °C to +125 °C
MSL ('Z' suffix only)	JEDEC J-STD-020C	Level 3

Protection

Short-circuit	Auto reset	47 A typical
Thermal		Auto recovery

Ordering Information

Model Number ⁽⁹⁾	Output Power (Max.)	Input Voltage	Output Voltage	Output Current (Min.)	Output Current (Max.)	Efficiency (Typical)	Regulation	
							Line	Load
PTH05030	108 W	4.5 - 5.5 Vdc	0.8 - 3.6 V	0 A	30 A	94%	±10 mV	±12 mV

Part Number System with Options

Product Family	Input Voltage	Output Current	Mechanical Package	Output Voltage Code	Pin Option	Mounting Options	Pin Option
PTH <small>Point-of-Load Alliance compatible</small>	05 <small>05 = 5 V</small>	03 <small>03 = 30 A</small>	0 <small>Always 0</small>	W <small>W = Wide</small>	A	S <small>D = Horizontal through-hole (Matte Sn) Z = Surface-mount (96.5/3.0/0.5 Sn/Ag/Cu pin solder material)</small>	T <small>No Suffix = Trays T = Tape and Reel⁽⁹⁾</small>

Output Voltage Adjustment

The ultra-wide output voltage trim range offers major advantages to users who select the PTH05030. It is no longer necessary to purchase a variety of modules in order to cover different output voltages. The output voltage can be trimmed in a range of 0.8 Vdc to 3.6 Vdc. When the PTH05030 converter leaves the factory the output has been adjusted to the default voltage of 0.8 V.

Efficiency Table (I_o = 10 A)

Output Voltage	Efficiency
V _o = 1.0 V	86%
V _o = 1.2 V	87%
V _o = 1.5 V	89%
V _o = 1.8 V	90%
V _o = 2.0 V	91%
V _o = 2.5 V	93%
V _o = 3.3 V	94%

Notes:

- Remote ON/OFF, Positive Logic
ON: Pin 3 open; or V > V_{in} - 0.5 V
OFF: Pin 3 GND; or V < 0.8 V (min - 0.2 V).
- See Figures 1 for safe operating curves.
- A 1500 µF electrolytic input capacitor is required for proper operation. The capacitor must be rated for a minimum of 900 mA rms of ripple current.
- An external output capacitor is not required for basic operation. Adding 330 µF of distributed capacitance at the load will improve the transient response.
- 1 A/µs load step, 50 to 100% I_{omax}, C_{out} = 330 µF.
- If utilized V_{out} will track applied voltage by ±0.3 V (up to V_o set point).
- The pre-bias start-up feature is not compatible with Auto-Track™. This is because when the module is under Auto-Track™ control, it is fully active and will sink current if the output voltage is below that of a back-feeding source. Therefore to ensure a pre-bias hold-off, one of the following two techniques must be followed when input power is first applied to the module. The Auto-Track™ function must either be disabled, or the module's output held off using the Inhibit pin. Refer to Application Note 157 for more details.
- Tape and reel packaging only available on the surface-mount versions.
- NOTICE: Some models do not support all options. Please contact your local Artesyn representative or use the on-line model number search tool at <http://www.artesyn.com/power> to find a suitable alternative.

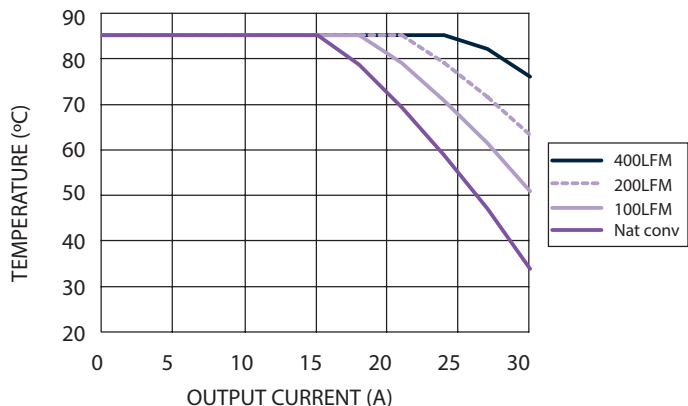

Figure 1 - Safe Operating Area
 Vin = 5 V, Output Voltage = 3.3 V (See Note A)

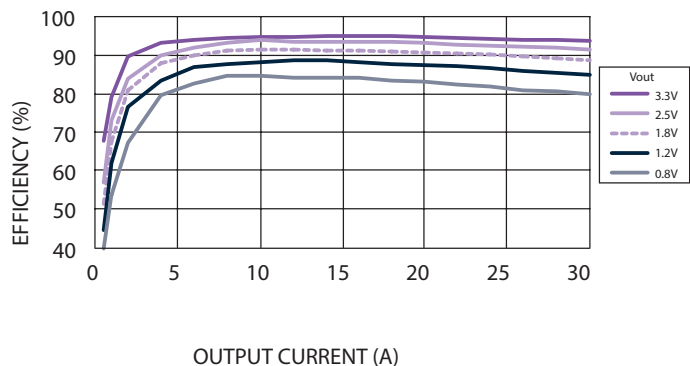

Figure 2 - Efficiency vs Load Current
 Vin = 5 V (See Note B)

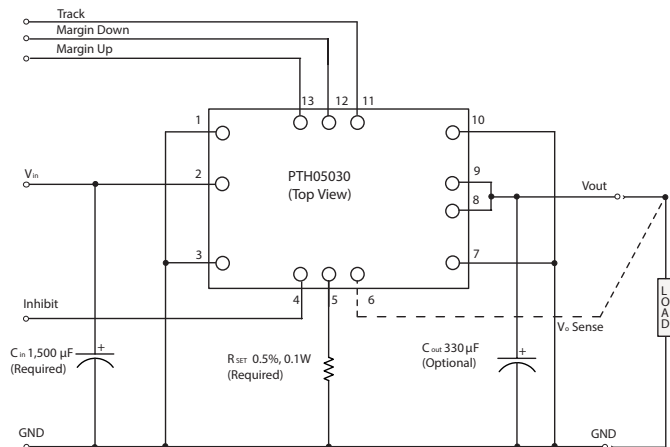

Figure 3 - Standard Application

Notes:

- A. SOA curves represent the conditions at which internal components are within the Artesyn derating guidelines.
- B. Characteristic data has been developed from actual products tested at 25 °C. This data is considered typical data for the converter.

Mechanical Drawings

Plated through-hole

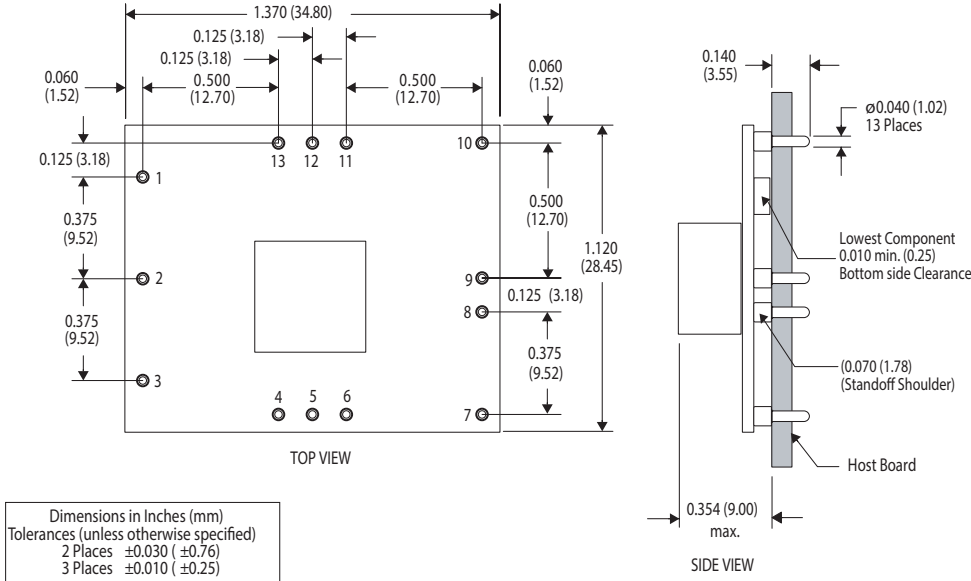

Pin	Function
1	Ground
2	Vin
3	Ground
4	Inhibit*
5	Vo adjust
6	Vo sense
7	Ground
8	Vout
9	Vout
10	Ground
11	Track
12	Margin down*
13	Margin up*

*Denotes negative logic:
 Open = Normal operation
 Ground = Function active

Surface-mount

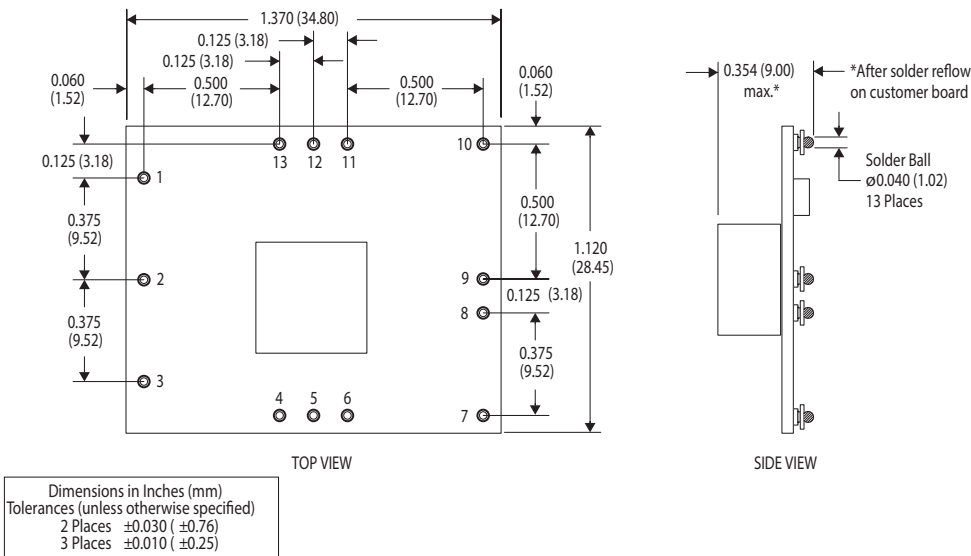

WORLDWIDE OFFICES

Americas

2900 S.Diablo Way
 Tempe, AZ 85282
 USA
 +1 888 412 7832

Europe (UK)

Waterfront Business Park
 Merry Hill, Dudley
 West Midlands, DY5 1LX
 United Kingdom
 +44 (0) 1384 842 211

Asia (HK)

14/F, Lu Plaza
 2 Wing Yip Street
 Kwun Tong, Kowloon
 Hong Kong
 +852 2176 3333

ARTESYN
 EMBEDDED TECHNOLOGIES

www.artesyn.com

While every precaution has been taken to ensure accuracy and completeness in this literature, Artesyn Embedded Technologies assumes no responsibility, and disclaims all liability for damages resulting from use of this information or for any errors or omissions. Artesyn Embedded Technologies, Artesyn and the Artesyn Embedded Technologies logo are trademarks and service marks of Artesyn Embedded Technologies, Inc. All other names and logos referred to are trade names, trademarks, or registered trademarks of their respective owners. © 2015 Artesyn Embedded Technologies, Inc.

For more information: www.artesyn.com/power
 For support: productsupport.ep@artesyn.com