

## DPDT USB Switch With Over Voltage Protection

### Features

- USB 2.0 Hi-speed DPDT switch
- Typical -3dB bandwidth: 1.2GHz (Single-ended)  
1.4GHz (Differential)
- Over voltage protection: 5.1V typical
- 24V DC protection on D+ and D- Ports
- +35V surge protection on D+ and D-
- Supply voltage range: 2.3V to 5.5V
- 5.9Ω switch on-resistance typical
- C<sub>ON</sub>: 5pF typical
- I<sub>CC</sub>: 36μA typical
- QFN 1.8mm X1.4mm X0.55mm-10L package

### Applications

- Smart phones
- Tablets
- USB Type-C
- PC/Notebook

### Typical Application Circuit

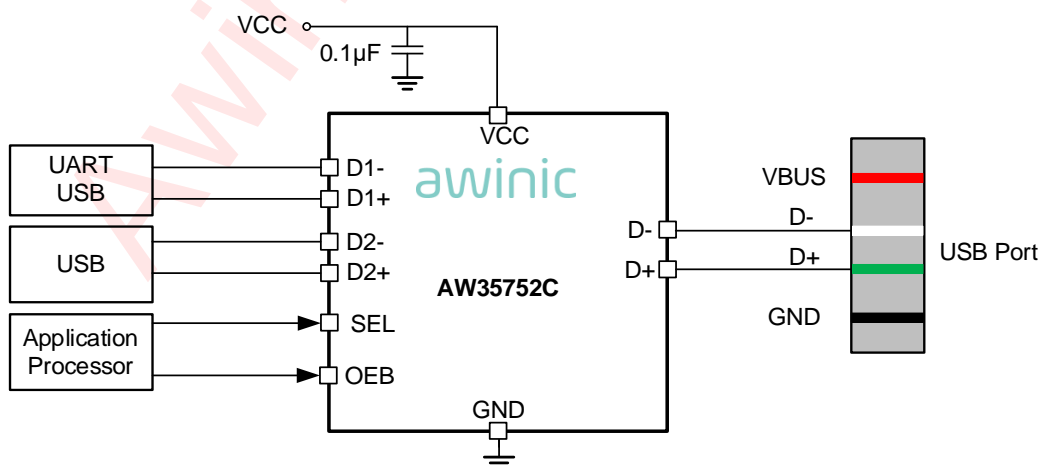

Figure 1 Typical Application Circuit of AW35752C

### General Description

The AW35752C is a Hi-Speed USB 2.0(480Mbps) DPDT(Double Pole Double Throw) switch with integrated protection for USB D+ and D-, it can be configured as a dual 1:2 or 2:1 switch.

The AW35752C protection on the D+/D- pins can tolerate up to 24V DC, when D+ or D- voltage is greater than the OVP(Over-Voltage Protection) threshold, the switch will be automatically shutdown to protect downstream devices.

The device operates over a 2.3V to 5.5V supply range with independent control bits for each switch pair and an on/off enable pin for shutdown mode.

The AW35752C is available in a QFN 1.8mm X1.4mm X0.55mm-10L package.

## Pin Configuration And Top Mark

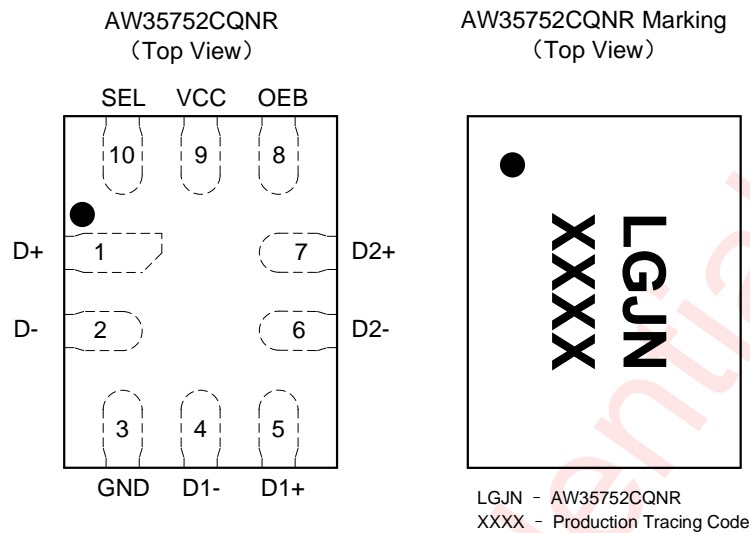

Figure 2 Pin Configuration and Top Mark

## Pin Definition

No.	NAME	DESCRIPTION
1	D+	Common high speed data port, differential +
2	D-	Common high speed data port, differential -
3	GND	Ground
4	D1-	Multiplexed high speed data port1, differential -
5	D1+	Multiplexed high speed data port1, differential +
6	D2-	Multiplexed high speed data port2, differential -
7	D2+	Multiplexed high speed data port2, differential +
8	OEB	Output enable, active low
9	VCC	Supply voltage
10	SEL	Switch select(logic Low = D+/- to D1+/- ,logic High = D+/- to D2+/-)

## Pin Functions

OEB	SEL	D- CONNECTION	D+ CONNECTION
H	X	High-Z	High-Z
L	L	D- to D1-	D+ to D1+
L	H	D- to D2-	D+ to D2+

## Functional Block Diagram

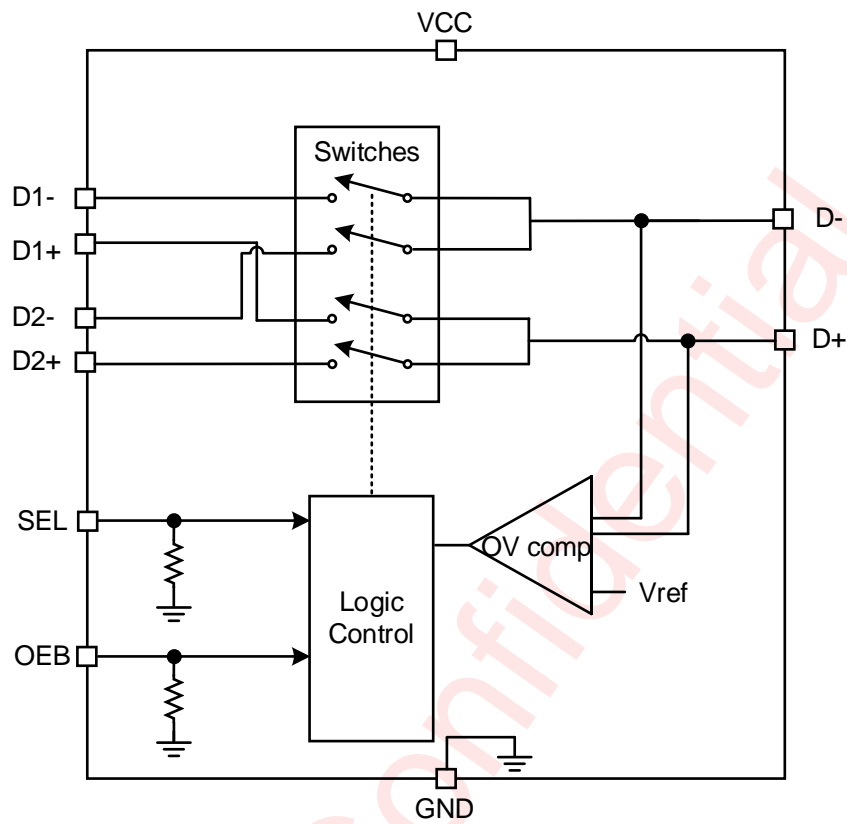

Figure 3 Functional Block Diagram

## Typical Application Circuits

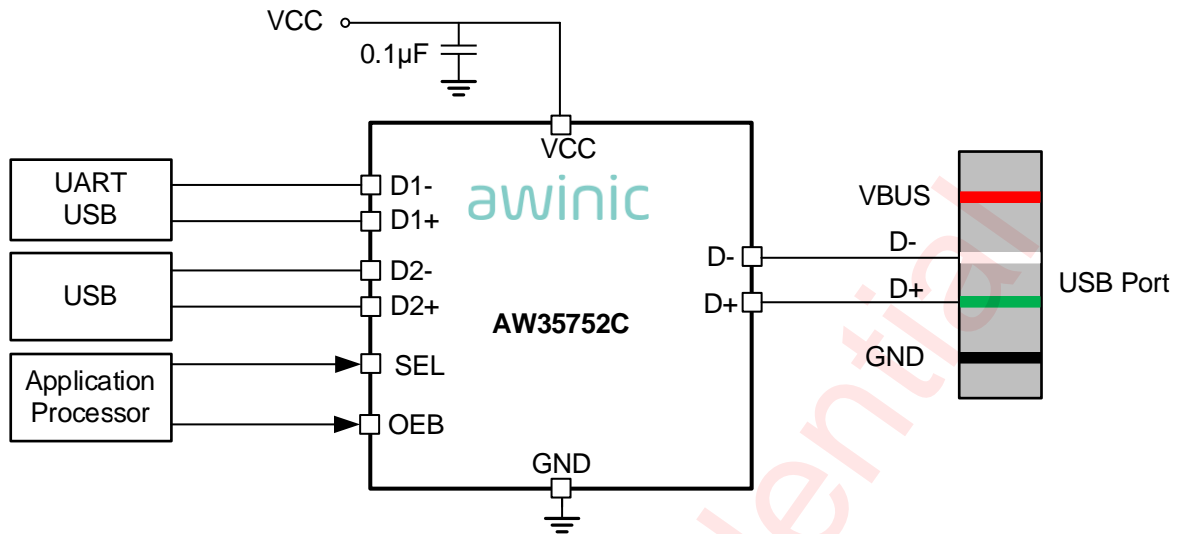

Figure 4 Typical Application Circuit of AW35752C

### Notice for Typical Application Circuits:

1. The AW35752C has internal 4.4-M $\Omega$  and 8.9-M $\Omega$  pull down resistors on SEL and OEB, so no external resistors are required on the logic pins.
2. Internal pull-down resistor on SEL pins ensures the D1+ and D1- channels are selected by default.

## Ordering Information

Part Number	Temperature	Package	Marking	Moisture Sensitivity Level	Environmental Information	Delivery Form
AW35752CQNR	-40°C~85°C	QFN 1.8mm X1.4mm X0.55mm -10L	LGJN	MSL1	ROHS+HF	4500 units/ Tape and Reel

**Absolute Maximum Ratings**<sup>(NOTE1)</sup>

PARAMETERS		RANGE
Supply voltage range VCC		-0.3V to 6V
Input/Output DC voltage(D+, D-)		-0.3V to 24V
Input/Output DC voltage(D1+, D1-, D2+, D2-)		-0.3V to 6V
Input voltage range	SEL, OEB	-0.3V to 6V
Junction-to-ambient thermal resistance $\theta_{JA}$		132°C/W
Maximum operating junction temperature T <sub>JMAX</sub>		150°C
Operating free-air temperature range		-40°C to 85°C
Storage temperature T <sub>STG</sub>		-65°C to 150°C
Lead temperature (soldering 10 seconds)		260°C
ESD		
Human Body Model (All pins, per JEDEC JS-001) <sup>(NOTE2)</sup>		±4kV
Charged Device Model (All pins, per JEDEC JS-002) <sup>(NOTE3)</sup>		±1.5kV
Latch-Up		
Test condition: JEDEC JESD78F-2022		±200mA

NOTE1: Conditions out of those ranges listed in "absolute maximum ratings" may cause permanent damages to the device. In spite of the limits above, functional operation conditions of the device should within the ranges listed in "recommended operating conditions". Exposure to absolute-maximum-rated conditions for prolonged periods may affect device reliability.

NOTE2: The human body model is a 100pF capacitor discharged through a 1.5kΩ resistor into each pin. Test method: ESDA/JEDEC JS-001-2017.

NOTE3: Test method: ESDA/JEDEC JS-002-2018.

**Recommended Operating Conditions**

PARAMETERS		MIN	MAX	UNIT
V <sub>CC</sub>	Supply voltage	2.3	5.5	V
V <sub>I/O</sub>	Analog input/output voltage(D <sub>±</sub> )	0	20	V
	Analog input/output voltage(D <sub>n±</sub> )	0	3.6	V
V <sub>I</sub>	Digital input voltage(SEL, OEB)	0	5.5	V
T <sub>A</sub>	Operating junction temperature T <sub>A</sub>	-40	85	°C

## Electrical Characteristics

$V_{CC}=3.3V$   $T_A = 25^{\circ}C$  for typical values (unless otherwise noted).

PARAMETER		TEST CONDITION	MIN	TYP	MAX	UNIT
$V_{CC}$	Supply voltage		2.3	3.3	5.5	V
$I_{CC}$	Active supply current	OEB=0V, SEL=0V, $0V < V_{D\pm} < 3.6V$	20	36	50	$\mu A$
$I_{CC\_PD}$	Standby supply current	OEB= $V_{CC}$ , SEL=0V		0.1	1.5	$\mu A$
<b>DC Characteristics</b>						
$R_{ON}$	On-state resistance	$V_{I/O}=0.4V$ , $I_{SINK}=8mA$		5.9	7.5	$\Omega$
$\Delta R_{ON}$	On-state resistance match between channels	$V_{I/O}=0.4V$ , $I_{SINK}=8mA$		0.1	0.3	$\Omega$
$R_{ON(FLAT)}$	ON-state resistance flatness	$V_{I/O}=0V$ to $0.4V$ , $I_{SINK}=8mA$		0.1	0.3	$\Omega$
$I_{OFF}$	I/O pin OFF leakage current on D+/D-	$V_{D\pm}=0V$ or $3.6V$ $V_{D1\pm}$ or $V_{D2\pm}=3.6V$ or $0V$		0.4	1	$\mu A$
		$V_{D\pm}=0V$ or $24V$ $V_{D1\pm}$ or $V_{D2\pm}=0V$	160	310	500	$\mu A$
$I_{ON}$	ON leakage current on D+/D-	$V_{D\pm}=0V$ or $3.6V$ $V_{D1\pm}$ and $V_{D2\pm}=high-Z$		0.4	1	$\mu A$
<b>Digital Characteristics</b>						
$V_{IH}$	Input logic high	SEL, OEB	0.9			V
$V_{IL}$	Input logic low	SEL, OEB			0.4	V
$R_{OEB}$	OEB pull-down resistor		4	8.9	14	$M\Omega$
$R_{SEL}$	SEL pull-down resistor		2	4.4	7	$M\Omega$
<b>Protection</b>						
$V_{OVP\_TH}$	OVP threshold	D+/D- rising	4.8	5.1	5.4	V
$V_{OVP\_HYST}$	OVP threshold hysteresis		100	270	400	mV
$V_{CLAMP\_V}$	Clamping voltage on $D_{1\pm}$ and $D_{2\pm}$ pins during surge	8/20 $\mu s$ surge test, OEB=0V, $R_L=open$			9	V
$t_{CLAMP}$	Clamp time during OVP	8/20 $\mu s$ surge test, OEB=0V, $R_L=open$		1.2		$\mu s$

**Electrical Characteristics (Continued)**

$V_{CC}=3.3V$   $T_A = 25^{\circ}C$  for typical values (unless otherwise noted).

PARAMETER		TEST CONDITION	MIN	TYP	MAX	UNIT
<b>Dynamic Characteristics</b>						
$C_{ON}$	IO pins ON capacitance	$V_{D\pm}=0V$ or $3.3V$ , $f=240MHz$ , switch ON	4.6	5	5.4	pF
$O_{ISO}$	Differential off isolation	$R_L=50\Omega$ , $C_L=5pF$ $f=100kHz$ , switch OFF	-70	-60	-50	dB
		$R_L=50\Omega$ , $C_L=5pF$ $f=240MHz$ , switch OFF	-30	-20	-10	dB
$X_{TALK}$	Channel to channel crosstalk	$R_L=50\Omega$ , $C_L=5pF$ $f=100kHz$ , switch ON	-70	-60	-50	dB
BW	-3dB bandwidth	$R_L=50\Omega$ , switch ON (Single-ended)	1.1	1.2	1.3	GHz
		$R_L=50\Omega$ , switch ON (Differential)	1.3	1.4	1.5	
$t_{switch}$	Switching time between channels (SEL1, SEL2 to output)	$V_{D\pm}=0.8V$ , $R_L=50\Omega$ , $C_L=5pF$ , $V_{CC}=2.3V$ to $5.5V$	0.5	1.5	5	$\mu s$
$t_{on}$	Device turn on time (OEB to output)			10	80	$\mu s$
$t_{off}$	Device turn off time (OEB to output)		30	160		ns
$t_{pd}$	Propagation delay		$V_{D\pm}=0.4V$ , $R_L=50\Omega$ , $C_L=5pF$ , $V_{CC}=2.3V$ to $5.5V$		200	1000

## Typical Characteristics

Ambient temperature is 25°C,  $V_{CC}=3.3V$ ,  $V_{D\pm}=0.4V$ , unless otherwise noted.

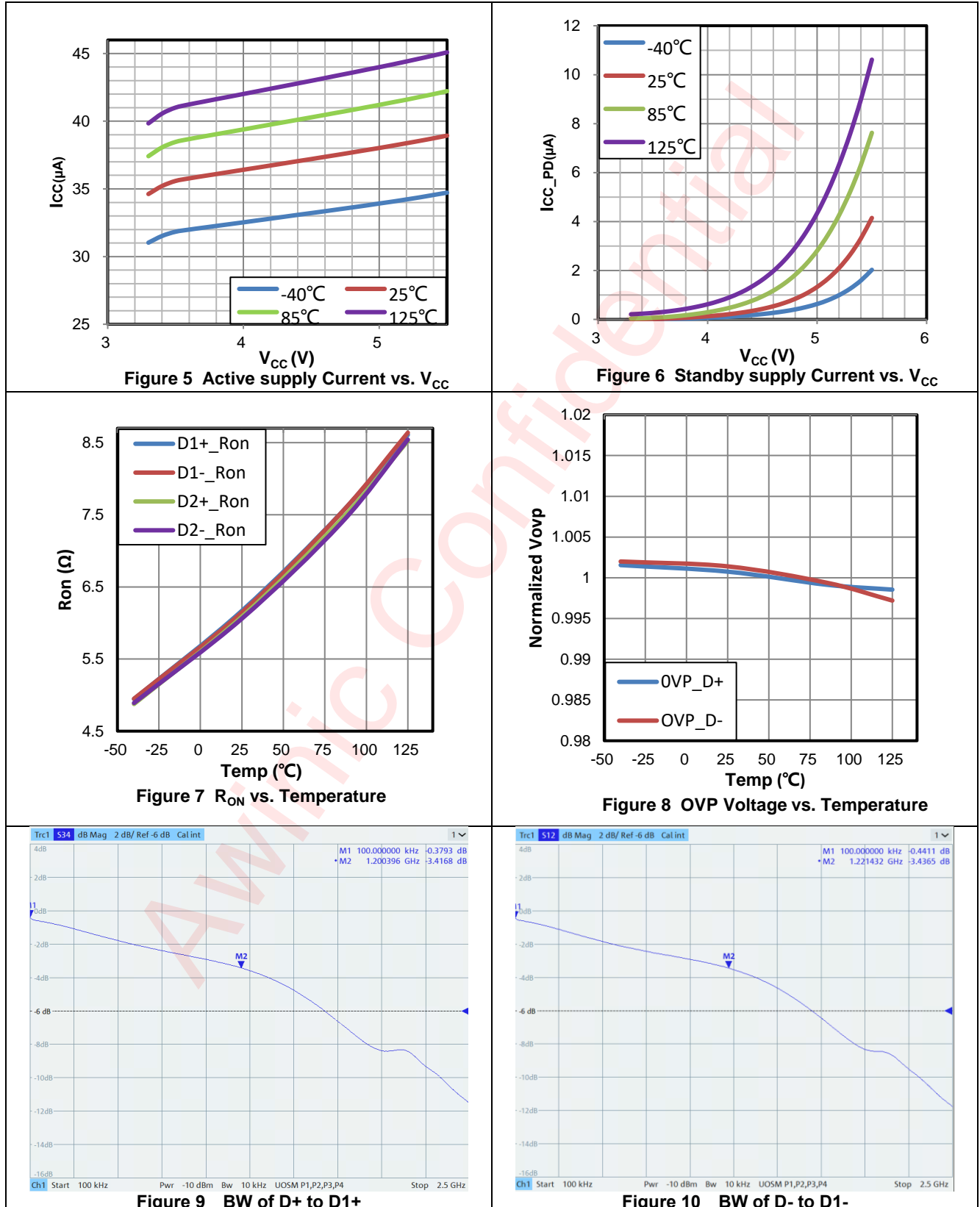

## Typical Characteristics (Continued)

Ambient temperature is 25°C,  $V_{CC} = 3.3V$ ,  $V_{D\pm} = 0.4V$ , unless otherwise noted.

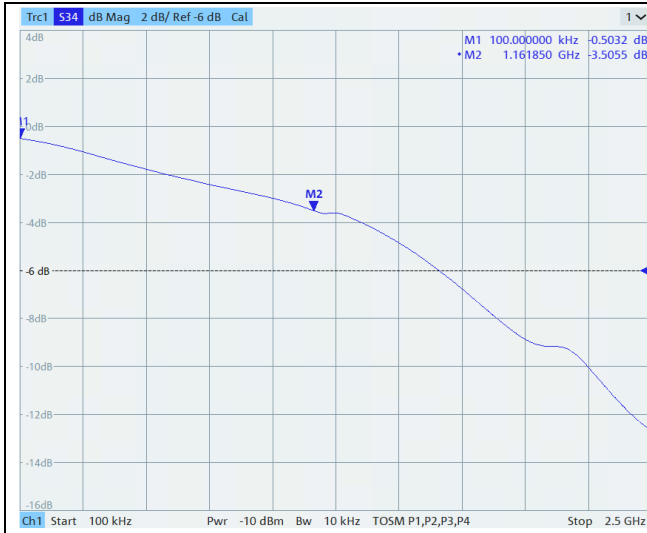

Figure 11 BW of D+ to D2+



Figure 12 BW of D- to D2-

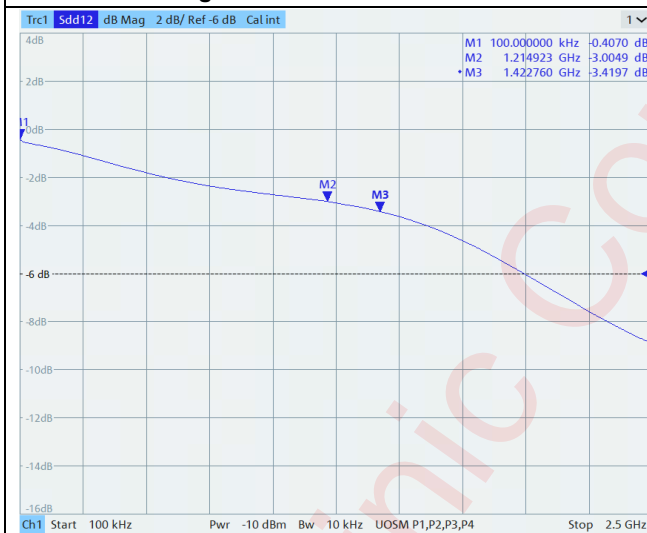

Figure 13 BW of D± to D1±



Figure 14 BW of D± to D2±

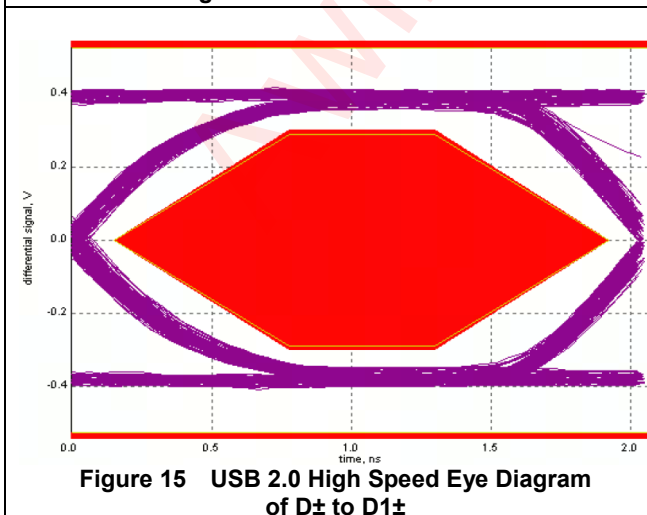

Figure 15 USB 2.0 High Speed Eye Diagram of D± to D1±

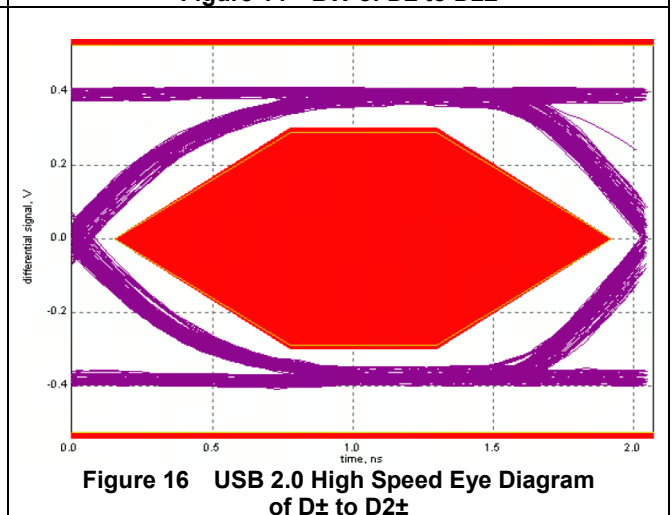

Figure 16 USB 2.0 High Speed Eye Diagram of D± to D2±

### Timing Diagram

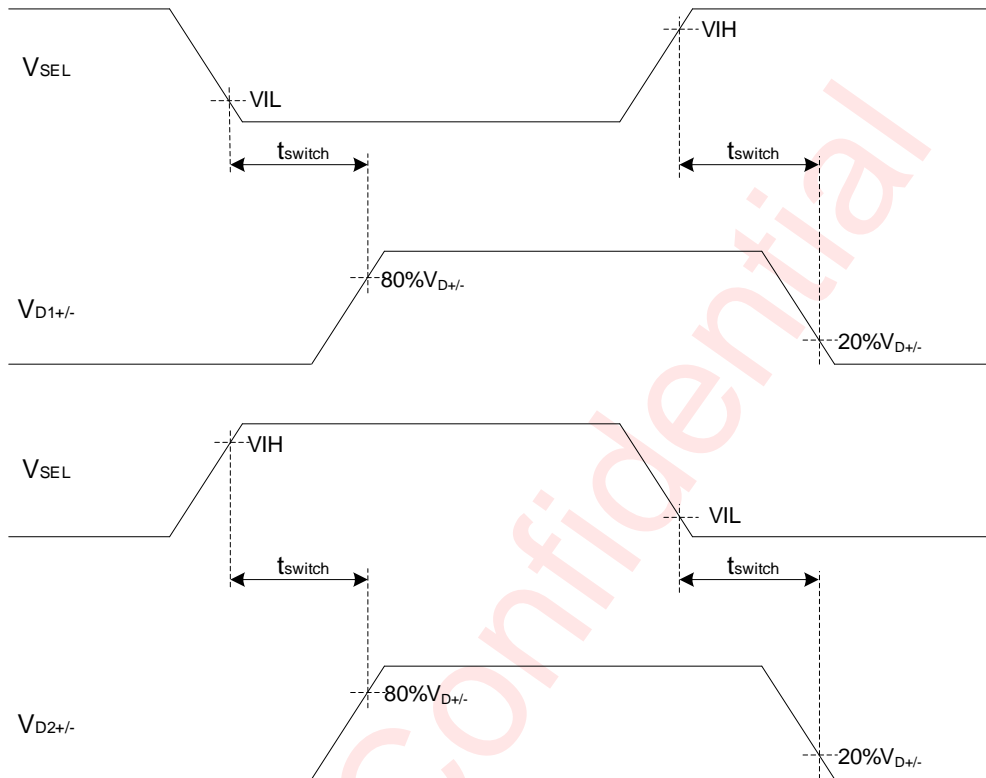

Figure 17 Switching Time Between Channels

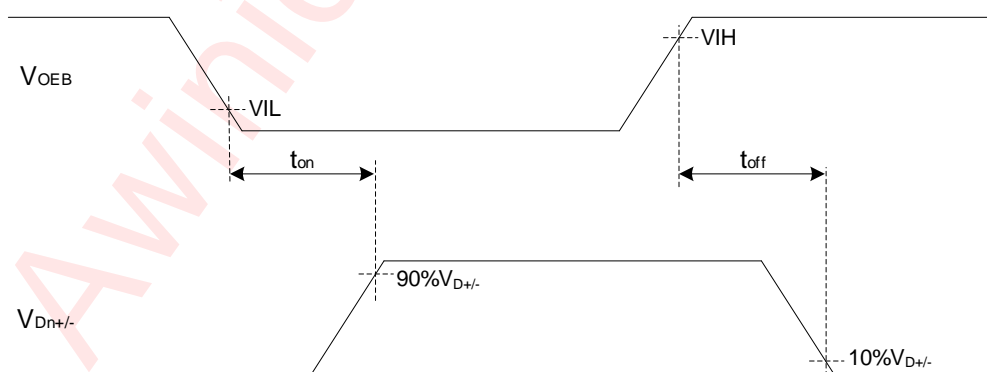

Figure 18 Device Turn On Time

## Timing Diagram (Continued)

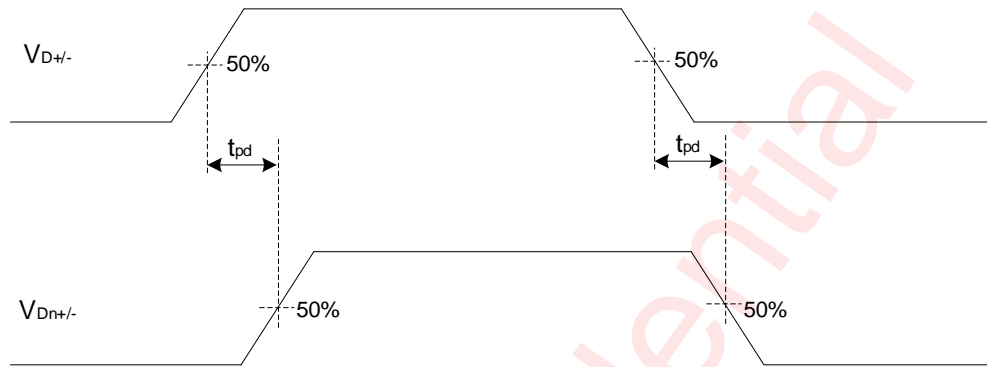

Figure 19 Propagation delay

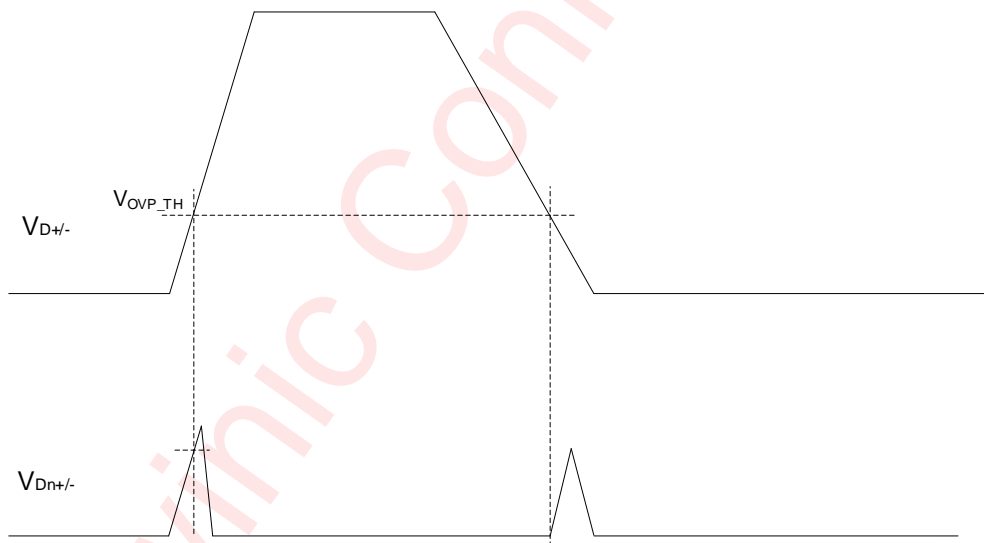

Figure 20 Overvoltage Protection

Application Information

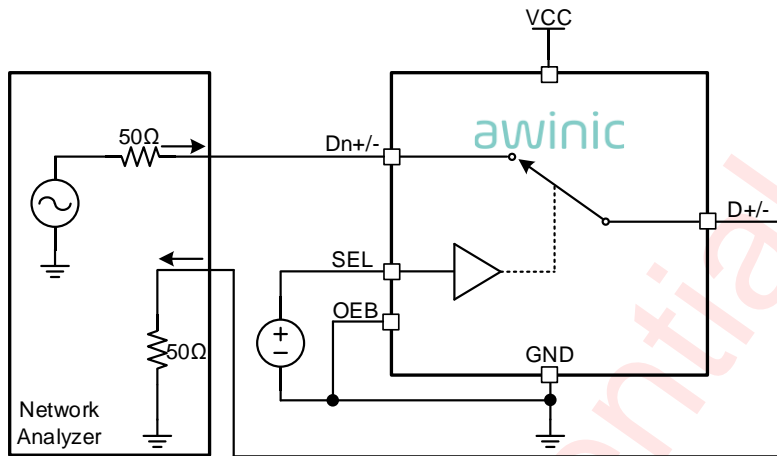

Figure 21 BW and Insertion Loss

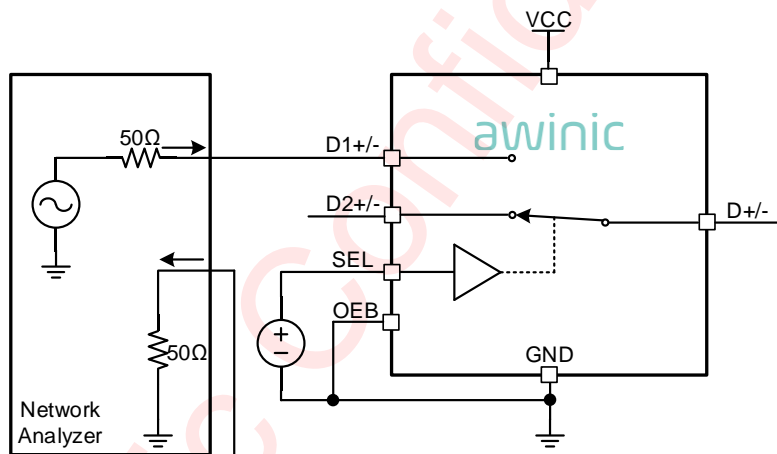

Figure 22 OFF Isolation

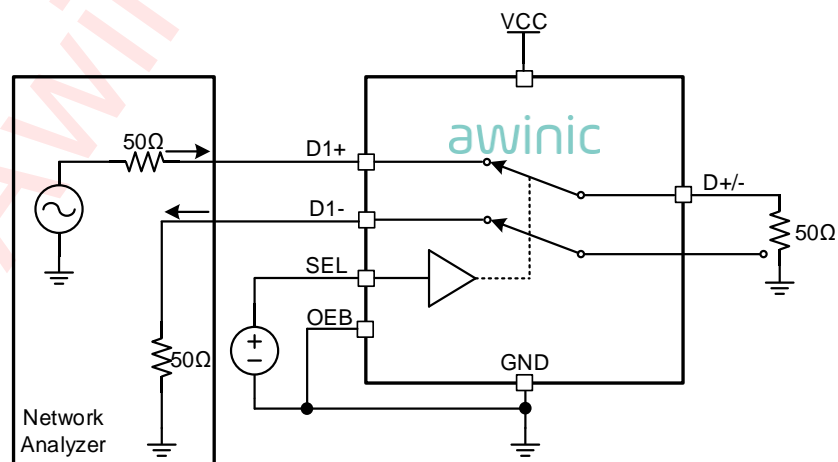

Figure 23 Cross Talk

## Detailed Functional Description

The AW35752C is bidirectional low-power dual port, high-speed, USB2.0 analog switch with integrated protection for USB D+ and D-, it can be configured as a dual 1:2 or 2:1 switch. The AW35752C will protect D+ and D- pins when stressed with voltages up to 24V. The device can pass signals with bandwidth 1.2GHz to maintain signal integrity and eye compliance.

### Powered-off Protection

When the AW35752C is powered off the I/Os of the device remain in a high-Z state. The crosstalk, off-isolation, and leakage remain within the Electrical Specifications.

### Over-Voltage Protection

AW35752C is designed to protect the system from damage. Over-voltage event happens when voltage on D+/D- exceeds 5.1V(typ.), and device will activate OVP to disconnect the switches.

### High Impedance Mode

When OEB is logic high, the AW35752C is in high impedance mode, all the signal paths are in Hi-Z state.

OEB	SEL	D- Connection	D+ Connection
H	X	High-Z	High-Z
L	L	D- to D1-	D+ to D1+
L	H	D- to D2-	D+ to D2+

## PCB Layout Consideration

To obtain the optimal performance of AW35752C, PCB layout should be considered carefully. Here are some guidelines:

1. Place supply bypass capacitors as close to VCC pin as possible and avoid placing the bypass capacitors near the D+/D- traces.
2. The differential characteristic impedance of D+ and D- traces is suggested to be  $90\Omega$ , and it's better to shield D+ and D- traces by ground planes.
3. Route the high-speed USB signals using a minimum of vias and corners which reduces signal reflections and impedance changes.
4. Do not route USB traces under or near crystals, oscillators, clock signal generators, switching regulators, mounting holes, magnetic devices or ICs that use or duplicate clock signals.
5. Avoid stubs on the high-speed USB signals because they cause signal reflections.
6. Route all high-speed USB signal traces over continuous GND planes, with no interruptions.

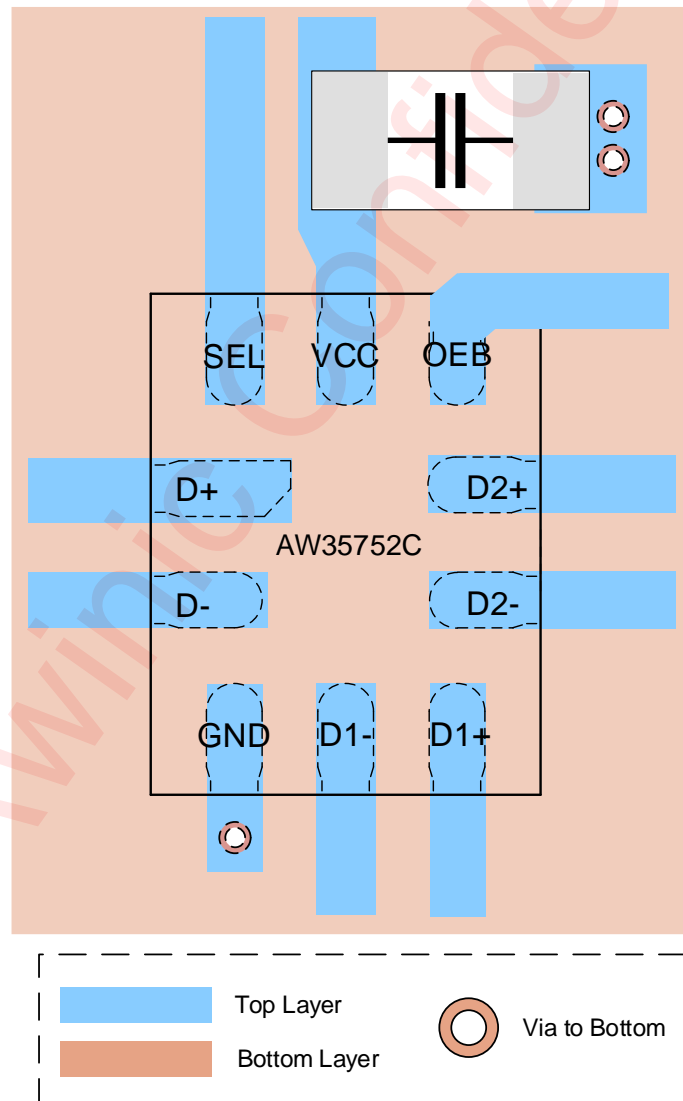

## Tape And Reel Information

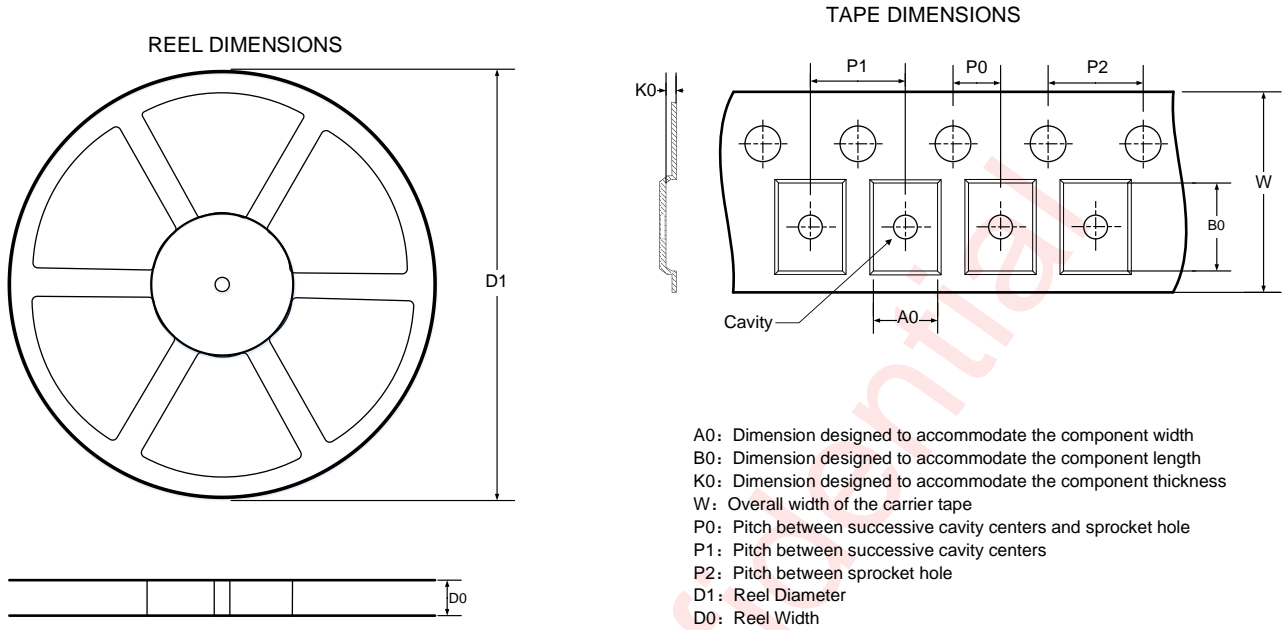

### QUADRANT ASSIGNMENTS FOR PIN 1 ORIENTATION IN TAPE

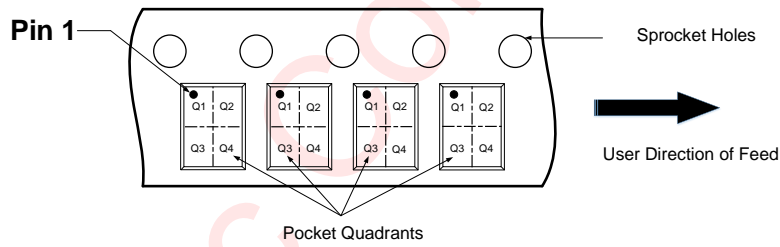

Note: The above picture is for reference only. Please refer to the value in the table below for the actual size

### DIMENSIONS AND PIN1 ORIENTATION

D1 (mm)	D0 (mm)	A0 (mm)	B0 (mm)	K0 (mm)	P0 (mm)	P1 (mm)	P2 (mm)	W (mm)	Pin1 Quadrant
178.00	8.40	1.58	2.04	0.73	2.00	4.00	4.00	8.00	Q1

All dimensions are nominal

Package Description

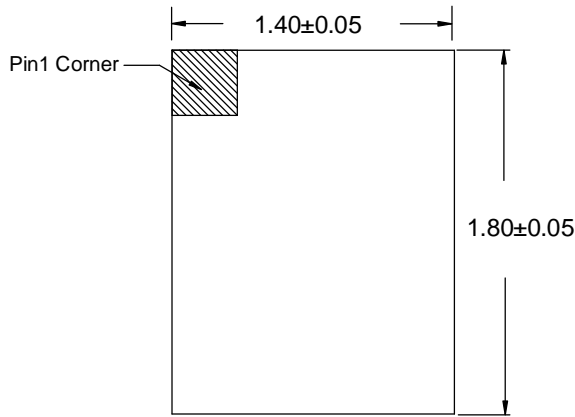

TOP VIEW

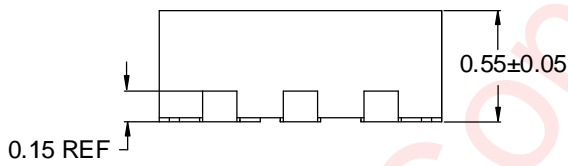

SIDE VIEW

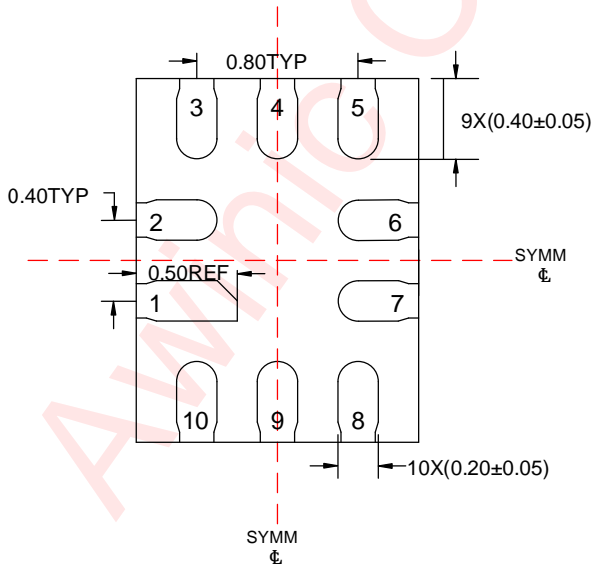

BOTTOM VIEW

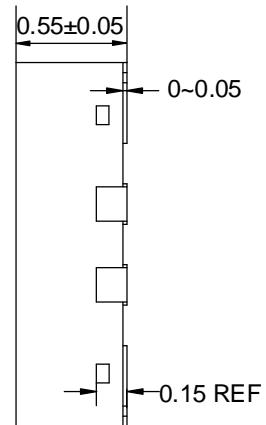

SIDE VIEW

Unit:mm

Land Pattern Data

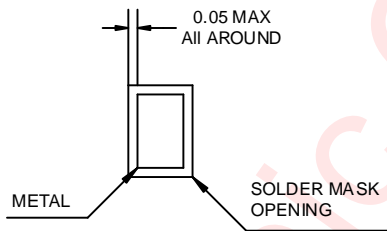
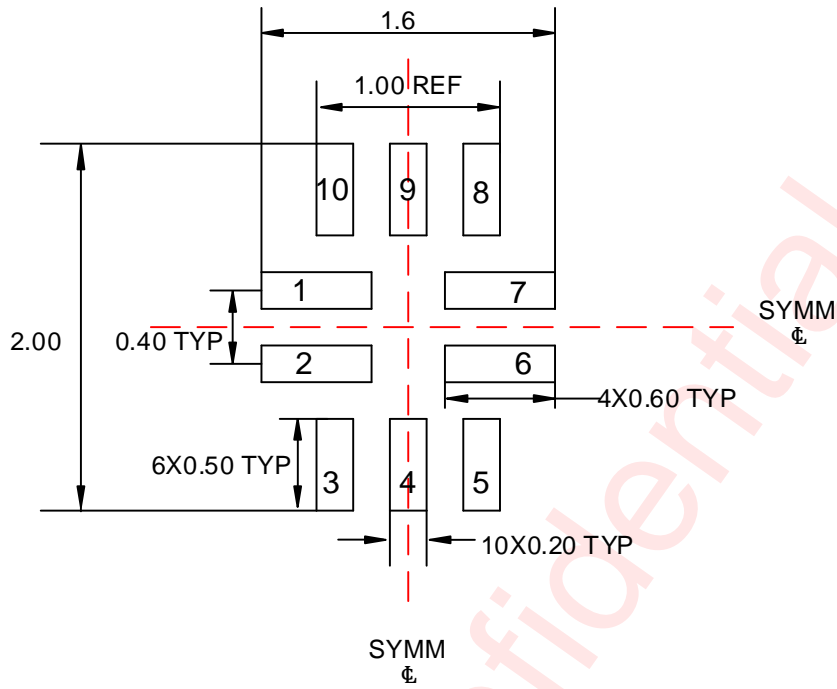

NON SOLDER MASK DEFINED

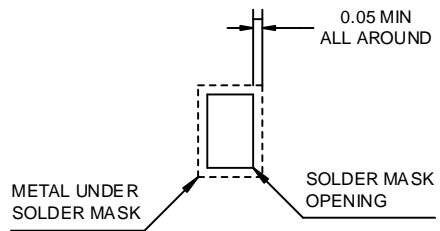

SOLDER MASK DEFINED

Unit:mm

## Revision History

Version	Date	Change Record
V1.0	Sept. 2024	Datasheet V1.0 released
V1.1	May. 2025	Digital Characteristics modification

Awinic Confidential

## Disclaimer

Information in this document is believed to be accurate and reliable. However, Shanghai AWINIC Technology Co., Ltd (AWINIC Technology) does not give any representations or warranties, expressed or implied, as to the accuracy or completeness of such information and shall have no liability for the consequences of use of such information.

AWINIC Technology reserves the right to make changes to information published in this document, including without limitation specifications and product descriptions, at any time and without notice. Customers shall obtain the latest relevant information before placing orders and shall verify that such information is current and complete. This document supersedes and replaces all information supplied prior to the publication hereof.

AWINIC Technology products are not designed, authorized or warranted to be suitable for use in medical, military, aircraft, space or life support equipment, nor in applications where failure or malfunction of an AWINIC Technology product can reasonably be expected to result in personal injury, death or severe property or environmental damage. AWINIC Technology accepts no liability for inclusion and/or use of AWINIC Technology products in such equipment or applications and therefore such inclusion and/or use is at the customer's own risk.

Applications that are described herein for any of these products are for illustrative purposes only. AWINIC Technology makes no representation or warranty that such applications will be suitable for the specified use without further testing or modification.

All products are sold subject to the general terms and conditions of commercial sale supplied at the time of order acknowledgement.

Nothing in this document may be interpreted or construed as an offer to sell products that is open for acceptance or the grant, conveyance or implication of any license under any copyrights, patents or other industrial or intellectual property rights.

Reproduction of AWINIC information in AWINIC data books or data sheets is permissible only if reproduction is without alteration and is accompanied by all associated warranties, conditions, limitations, and notices. AWINIC is not responsible or liable for such altered documentation. Information of third parties may be subject to additional restrictions.

Resale of AWINIC components or services with statements different from or beyond the parameters stated by AWINIC for that component or service voids all express and any implied warranties for the associated AWINIC component or service and is an unfair and deceptive business practice. AWINIC is not responsible or liable for any such statements.